

HA-2540

400MHz, Fast Settling Operational Amplifier

FN2897
Rev.5.00
July 2003

The Intersil HA-2540 is a wideband, very high slew rate, monolithic operational amplifier featuring superior speed and bandwidth characteristics. Bipolar construction coupled with dielectric isolation allows this truly differential device to deliver outstanding performance in circuits where closed loop gain is 10 or greater. Additionally, the HA-2540 has a drive capability of $\pm 10V$ into a $1k\Omega$ load. Other desirable characteristics include low input voltage noise, low offset voltage, and fast settling time.

A $400V/\mu s$ slew rate ensures high performance in video and pulse amplification circuits, while the 400MHz gain-bandwidth product is ideally suited for wideband signal amplification. A settling time of 140ns also makes the HA-2540 an excellent selection for high speed Data Acquisition Systems.

Refer to Application Note AN541 and Application Note AN556 for more information on High Speed Op Amp applications.

For a lower power version of this product, please see the HA-2850 datasheet.

Features

- Very High Slew Rate $400V/\mu s$
- Fast Settling Time 140ns
- Wide Gain Bandwidth ($A_V \geq 10$) 400MHz
- Power Bandwidth 6MHz
- Low Offset Voltage 8mV
- Input Voltage Noise $6nV/\sqrt{Hz}$
- Output Voltage Swing $\pm 10V$
- Monolithic Bipolar Construction

Applications

- Pulse and Video Amplifiers
- Wideband Amplifiers
- High Speed Sample-Hold Circuits
- Fast, Precise D/A Converters

Ordering Information

PART NUMBER	TEMP. RANGE (°C)	PACKAGE	PKG. DWG. #
HA1-2540-5	0 to 75	14 Ld CERDIP	F14.3

Pinout

HA-2540 (CERDIP)
TOP VIEW

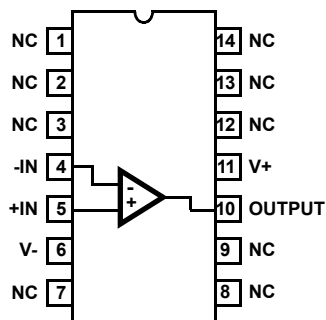

Absolute Maximum Ratings

Voltage Between V+ and V- Terminals 35V
 Differential Input Voltage 6V
 Output Current 33mA_{RMS} Continuous, 50mA_{PEAK}

Operating Conditions

Temperature Range
 HA-2540-5 0°C to 75°C

CAUTION: Stresses above those listed in "Absolute Maximum Ratings" may cause permanent damage to the device. This is a stress only rating and operation of the device at these or any other conditions above those indicated in the operational sections of this specification is not implied.

NOTES:

1. Maximum power dissipation with load conditions must be designed to maintain the maximum junction temperature below 175°C for the ceramic package, and below 150°C for the plastic package. By using Application Note AN556 on Safe Operating Area Equations, along with the thermal resistances, proper load conditions can be determined. Heat sinking is recommended above 75°C.
2. θ_{JA} is measured with the component mounted on an evaluation PC board in free air.

Thermal Information

Thermal Resistance (Typical, Note 2) θ_{JA} (°C/W) θ_{JC} (°C/W)
 CERDIP Package 75 20
 Maximum Internal Power Dissipation (Note 1)
 Maximum Junction Temperature (Ceramic Package) 175°C
 Maximum Storage Temperature Range -65°C to 150°C
 Maximum Lead Temperature (Soldering 10s) 300°C

Electrical Specifications $V_{SUPPLY} = \pm 15V$, $R_L = 1k\Omega$, $C_L < 10pF$, Unless Otherwise Specified

PARAMETER	TEMP (°C)	MIN	TYP	MAX	UNITS
INPUT CHARACTERISTICS					
Offset Voltage	25	-	8	15	mV
	Full	-	13	20	mV
Average Offset Voltage Drift	Full	-	20	-	$\mu V/^\circ C$
Bias Current	25	-	5	20	μA
	Full	-	-	25	μA
Offset Current	25	-	1	6	μA
	Full	-	-	8	μA
Input Resistance	25	-	10	-	k Ω
Input Capacitance	25	-	1	-	pF
Common Mode Range	Full	± 10	-	-	V
Input Noise Current (f = 1kHz, $R_{SOURCE} = 0\Omega$)	25	-	6	-	pA/\sqrt{Hz}
Input Noise Voltage (f = 1kHz, $R_{SOURCE} = 0\Omega$)	25	-	6	-	nV/\sqrt{Hz}
TRANSFER CHARACTERISTICS					
Large Signal Voltage Gain (Note 3)	25	10	15	-	kV/V
	Full	5	-	-	kV/V
Common-Mode Rejection Ratio (Note 4)	Full	60	72	-	dB
Minimum Stable Gain	25	10	-	-	V/V
Gain Bandwidth Product (Notes 5, 6)	25	-	400	-	MHz
OUTPUT CHARACTERISTICS					
Output Voltage Swing (Notes 3, 10)	Full	± 10	-	-	V
Output Current (Note 3)	25	± 10	± 20	-	mA
Output Resistance	25	-	30	-	Ω
Full Power Bandwidth (Notes 3, 7)	25	5.5	6	-	MHz
TRANSIENT RESPONSE (Note 8)					
Rise Time	25	-	14	-	ns
Overshoot	25	-	5	-	%
Slew Rate	25	320	400	-	V/ μs
Settling Time: 10V Step to 0.1%	25	-	140	-	ns

Electrical Specifications $V_{SUPPLY} = \pm 15V$, $R_L = 1k\Omega$, $C_L < 10pF$, Unless Otherwise Specified **(Continued)**

PARAMETER	TEMP (°C)	MIN	TYP	MAX	UNITS
POWER REQUIREMENTS					
Supply Current	Full	-	20	25	mA
Power Supply Rejection Ratio (Note 9)	Full	60	70	-	dB

NOTES:

3. $R_L = 1k\Omega$, $V_O = \pm 10V$.
4. $V_{CM} = \pm 10V$.
5. $V_O = 90mV$.
6. $A_V = 10$.
7. Full power bandwidth guaranteed based on slew rate measurement using: $FPBW = \frac{\text{Slew Rate}}{2\pi V_{PEAK}}$.
8. Refer to Test Circuits section of the data sheet.
9. $V_{SUPPLY} = +5V, -15V$ and $+15V, -5V$.
10. Guaranteed range for output voltage is $\pm 10V$. Functional operation outside of this range is not guaranteed.

Test Circuits and Waveforms

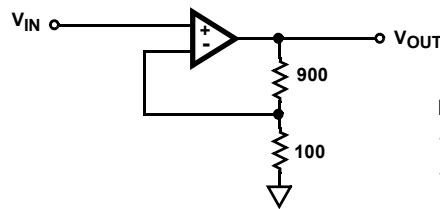

NOTES:

11. $A_V = +10$.
12. $C_L \leq 10pF$.

FIGURE 1. LARGE AND SMALL SIGNAL RESPONSE TEST CIRCUIT

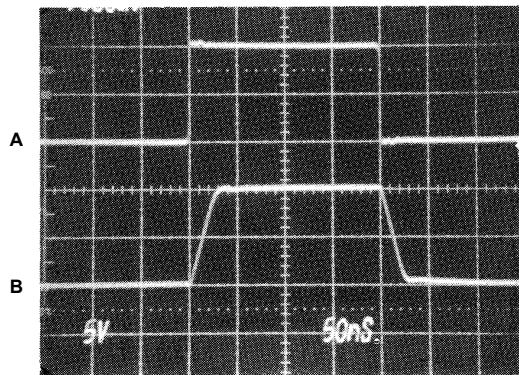

Vertical Scale: A = 0.5V/Div., B = 5.0V/Div.
Horizontal Scale: 50ns/Div.

LARGE SIGNAL RESPONSE

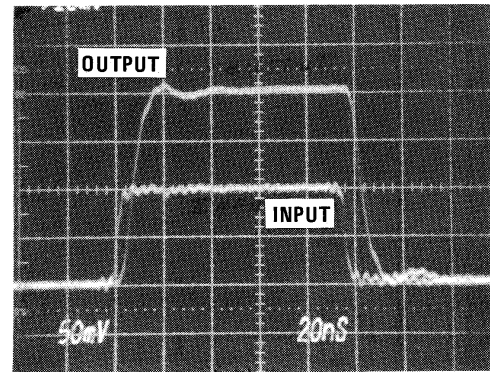

Vertical Scale: Input = 10mV/Div.; Output = 50mV/Div.
Horizontal Scale: 20ns/Div.

SMALL SIGNAL RESPONSE

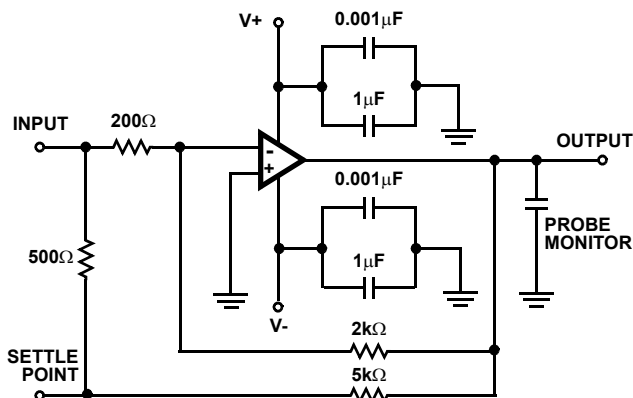

NOTES:

13. $A_V = -10$.
14. Load Capacitance should be less than 10pF. Turn on time delay typically 4ns.
15. It is recommended that resistors be carbon composition and the feedback and summing network ratios be matched to 0.1%.
16. SETTLE POINT (Summing Node) capacitance should be less than 10pF. For optimum settling time results, it is recommended that the test circuit be constructed directly onto the device pins. A Tektronix 568 Sampling Oscilloscope with S-3A sampling heads is recommended as a settle point monitor.

FIGURE 2. SETTLING TIME TEST CIRCUIT

Schematic Diagram

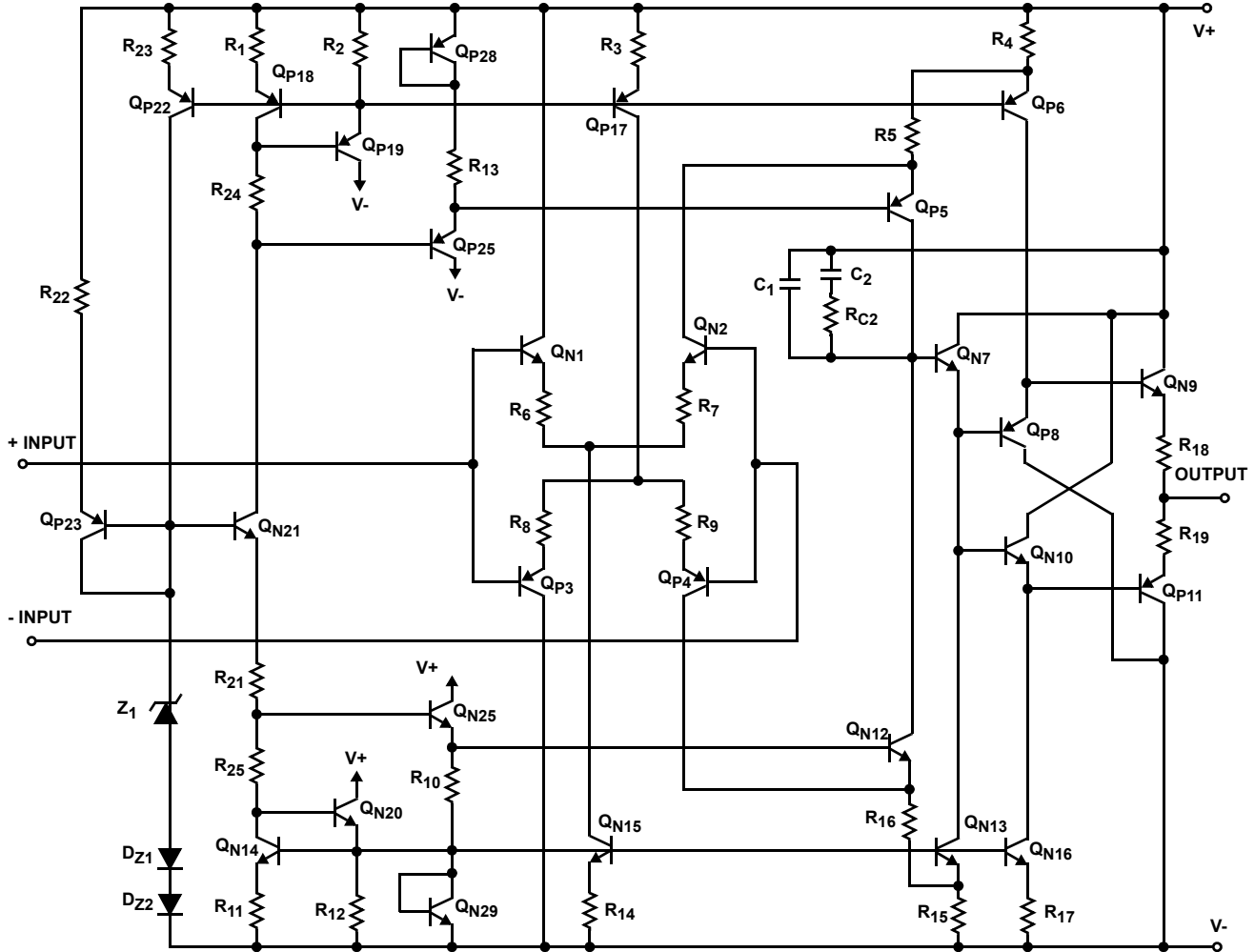

Typical Applications

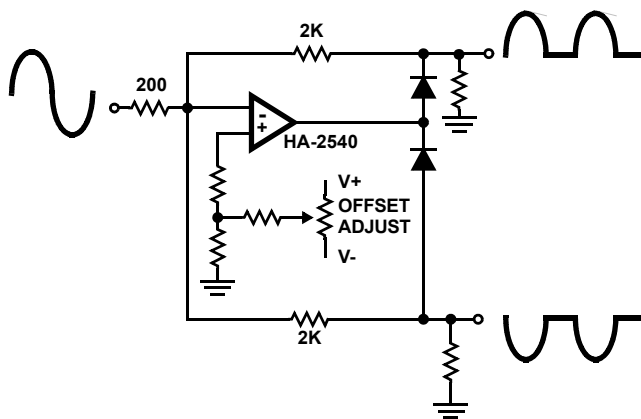

NOTE: With one HA-2540 and two low capacitance switching diodes, signals exceeding 10MHz can be separated. This circuit is most useful for full wave rectification, AM detectors or sync generation.

FIGURE 3. WIDEBAND SIGNAL SPLITTER

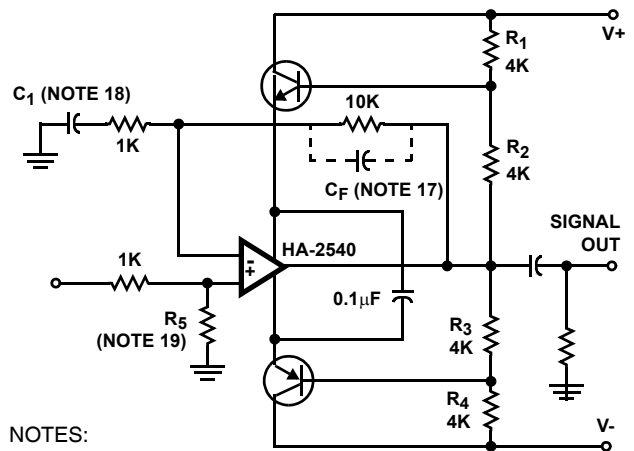

NOTES:

- 17. Used for experimental purposes. $C_F \cong 3pF$.
- 18. C_1 is optional ($0.001\mu F \rightarrow 0.01\mu F$ ceramic).
- 19. R_5 is optional and can be utilized to reduce input signal amplitude and/or balance input conditions. $R_5 = 500\Omega$ to $1k\Omega$.

FIGURE 4. BOOTSTRAPPING FOR MORE OUTPUT CURRENT AND VOLTAGE SWING

Refer to Application Note AN541 For Further Application Information.

Typical Performance Curves

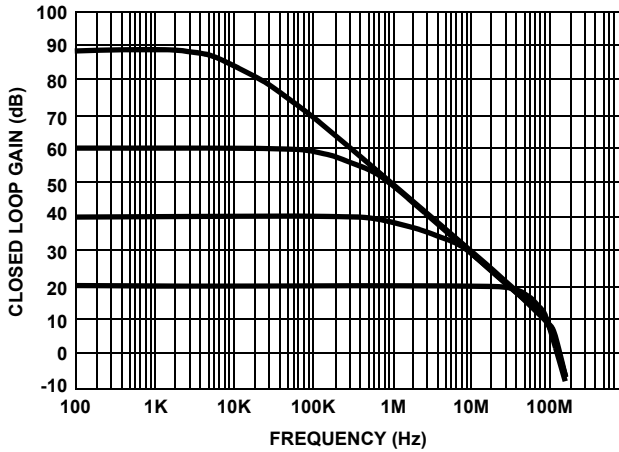

FIGURE 5. CLOSED LOOP FREQUENCY RESPONSE

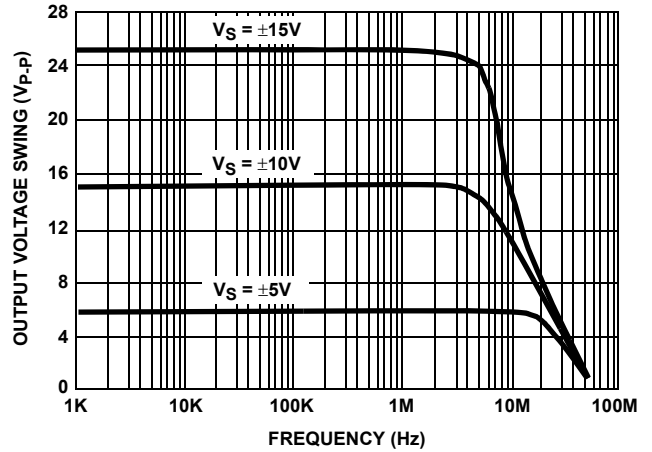

FIGURE 6. OUTPUT VOLTAGE SWING vs FREQUENCY

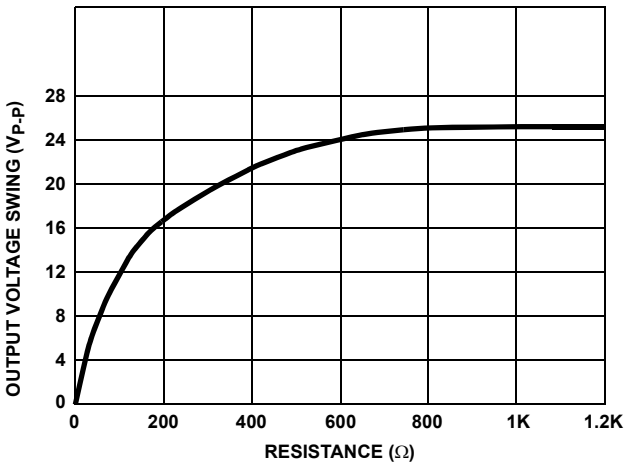

FIGURE 7. OUTPUT VOLTAGE SWING vs LOAD RESISTANCE

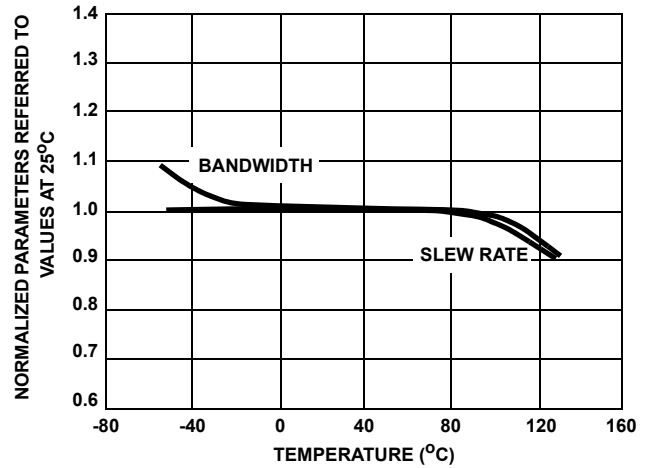

FIGURE 8. NORMALIZED AC PARAMETERS vs TEMPERATURE

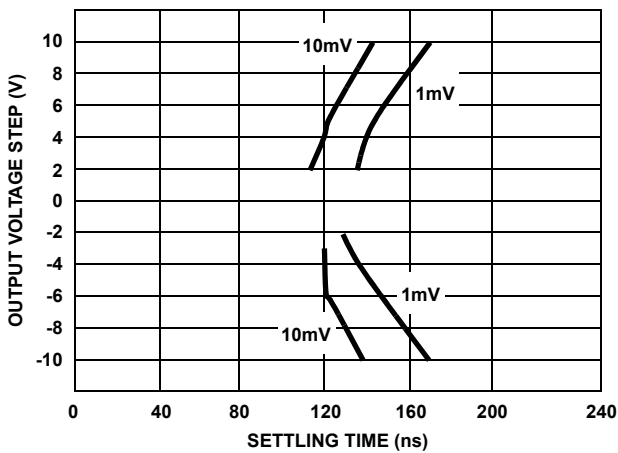

FIGURE 9. SETTLING TIME FOR VARIOUS OUTPUT STEP VOLTAGES

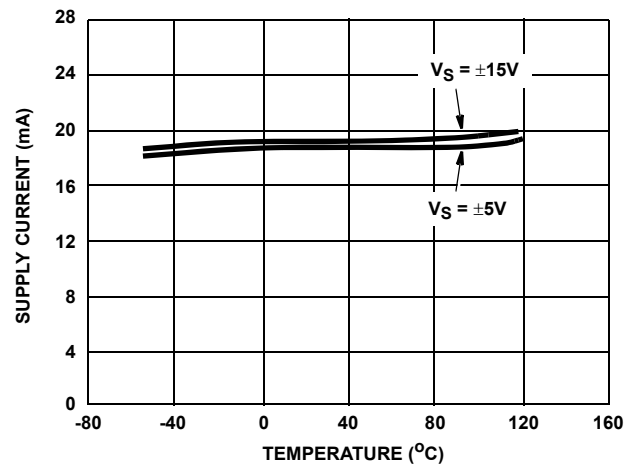

FIGURE 10. POWER SUPPLY CURRENT vs TEMPERATURE

Typical Performance Curves (Continued)

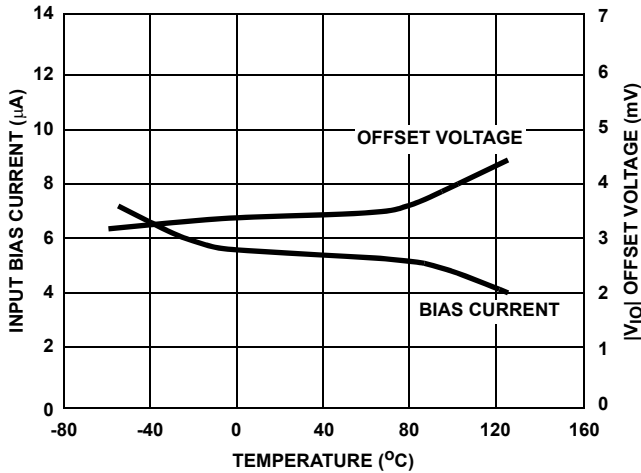

FIGURE 11. INPUT OFFSET VOLTAGE AND BIAS CURRENT vs TEMPERATURE

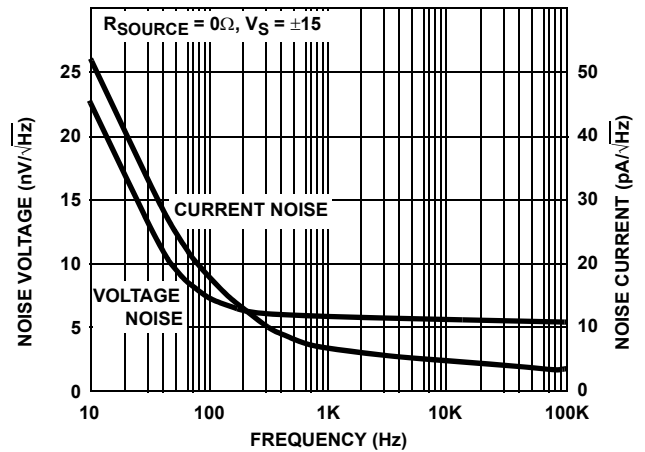
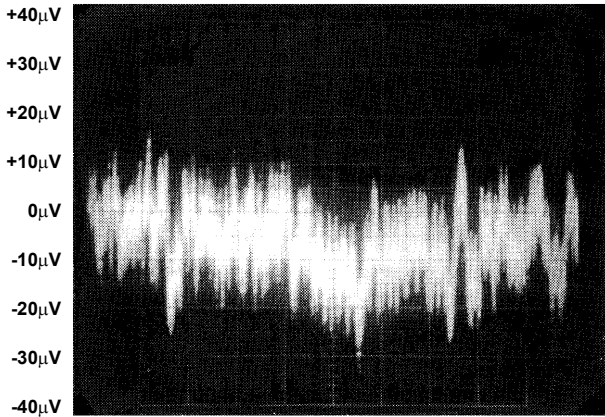

FIGURE 12. INPUT NOISE VOLTAGE AND NOISE CURRENT vs FREQUENCY



Vertical Scale: 10mV/Div.
Horizontal Scale: 50ms/Div.

FIGURE 13. BROADBAND NOISE (0.1Hz TO 1MHz)

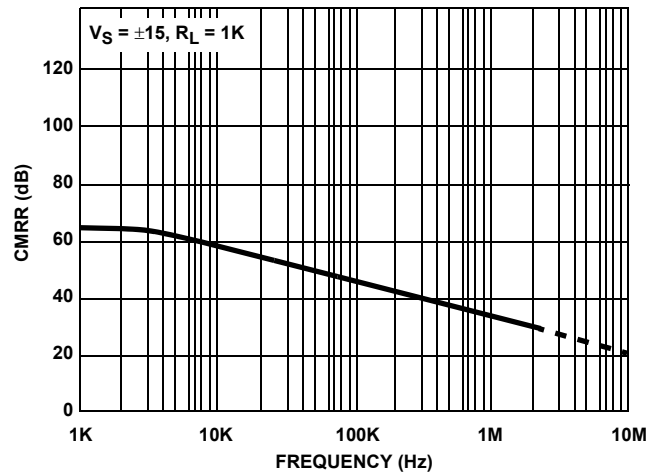

FIGURE 14. COMMON MODE REJECTION RATIO vs FREQUENCY

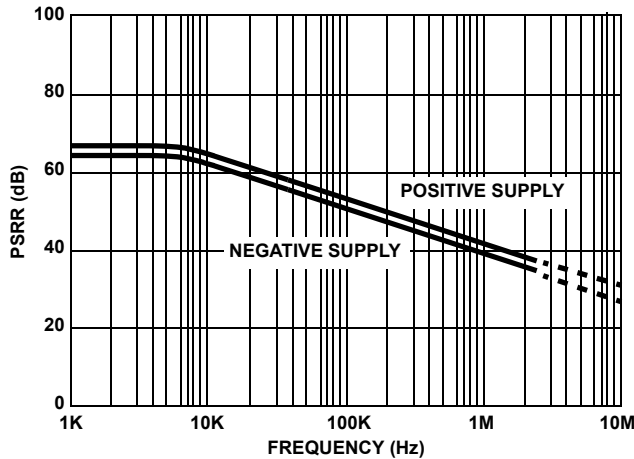

FIGURE 15. POWER SUPPLY REJECTION RATIO vs FREQUENCY

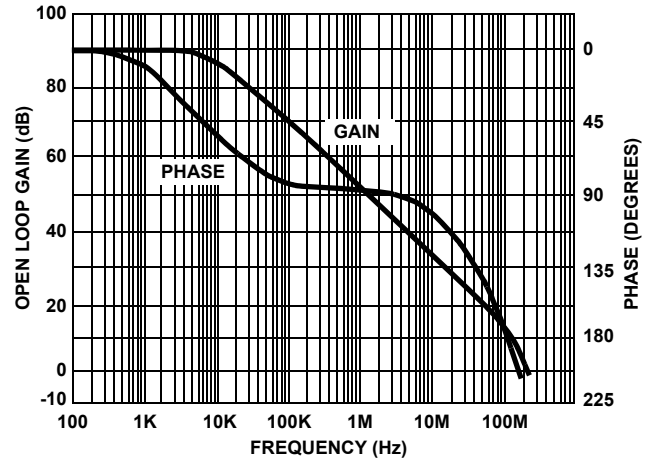

FIGURE 16. OPEN LOOP GAIN/PHASE vs FREQUENCY

Die Characteristics

DIE DIMENSIONS:

62 mils x 76 mils x 19 mils
1575 μm x 1930 μm x 483 μm

METALLIZATION:

Type: Al, 1% Cu
Thickness: 16kÅ ±2kÅ

PASSIVATION:

Type: Nitride (Si₃N₄) over Silox (SiO₂, 5% Phos.)
Silox Thickness: 12kÅ ±2kÅ
Nitride Thickness: 3.5kÅ ±1.5kÅ

SUBSTRATE POTENTIAL (Powered Up):

V-

TRANSISTOR COUNT:

30

PROCESS:

Bipolar Dielectric Isolation

Metalization Mask Layout

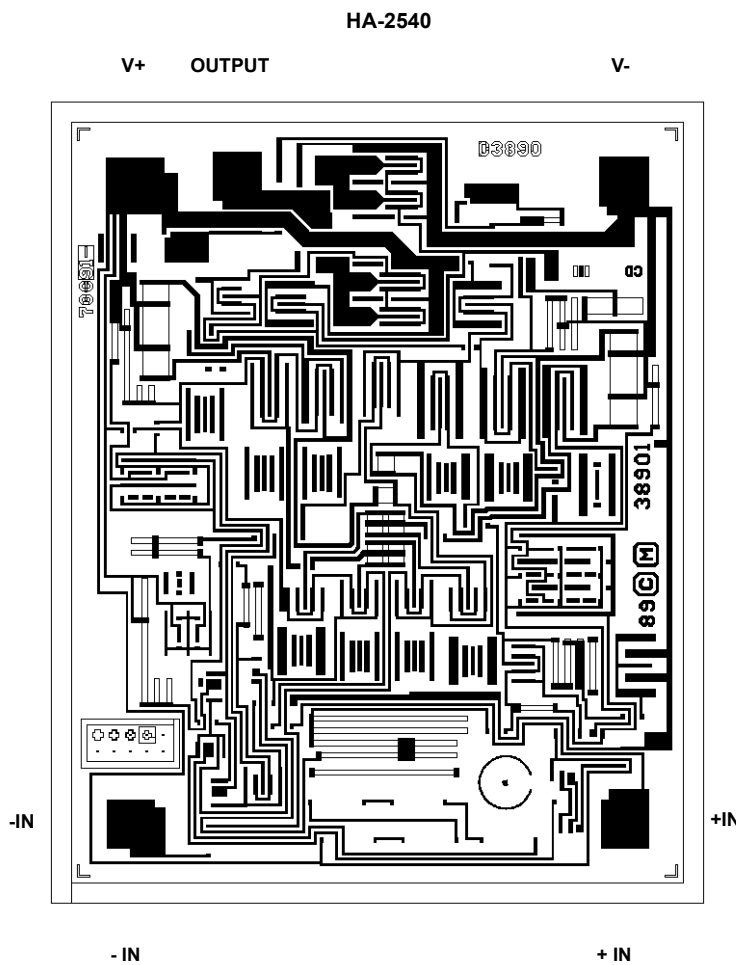

Ceramic Dual-In-Line Frit Seal Packages (CERDIP)

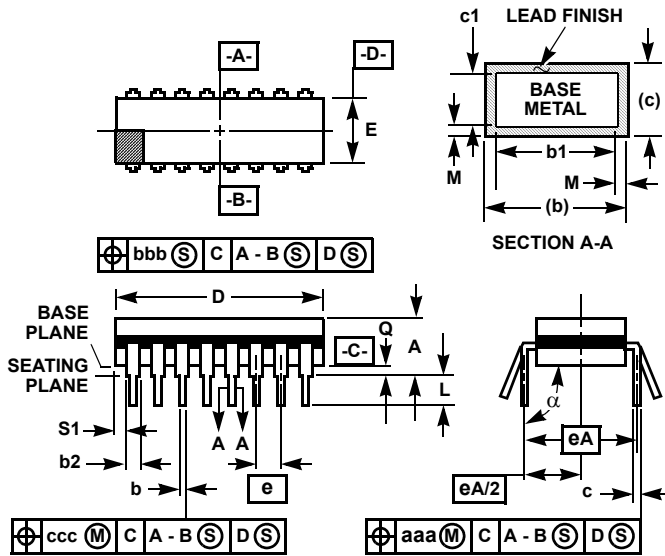

**F14.3 MIL-STD-1835 GDIP1-T14 (D-1, CONFIGURATION A)
14 LEAD CERAMIC DUAL-IN-LINE FRIT SEAL PACKAGE**

SYMBOL	INCHES		MILLIMETERS		NOTES
	MIN	MAX	MIN	MAX	
A	-	0.200	-	5.08	-
b	0.014	0.026	0.36	0.66	2
b1	0.014	0.023	0.36	0.58	3
b2	0.045	0.065	1.14	1.65	-
b3	0.023	0.045	0.58	1.14	4
c	0.008	0.018	0.20	0.46	2
c1	0.008	0.015	0.20	0.38	3
D	-	0.785	-	19.94	5
E	0.220	0.310	5.59	7.87	5
e	0.100 BSC		2.54 BSC		-
eA	0.300 BSC		7.62 BSC		-
eA/2	0.150 BSC		3.81 BSC		-
L	0.125	0.200	3.18	5.08	-
Q	0.015	0.060	0.38	1.52	6
S1	0.005	-	0.13	-	7
α	90°	105°	90°	105°	-
aaa	-	0.015	-	0.38	-
bbb	-	0.030	-	0.76	-
ccc	-	0.010	-	0.25	-
M	-	0.0015	-	0.038	2, 3
N	14		14		8

Rev. 0 4/94

NOTES:

1. Index area: A notch or a pin one identification mark shall be located adjacent to pin one and shall be located within the shaded area shown. The manufacturer's identification shall not be used as a pin one identification mark.
2. The maximum limits of lead dimensions b and c or M shall be measured at the centroid of the finished lead surfaces, when solder dip or tin plate lead finish is applied.
3. Dimensions b1 and c1 apply to lead base metal only. Dimension M applies to lead plating and finish thickness.
4. Corner leads (1, N, N/2, and N/2+1) may be configured with a partial lead paddle. For this configuration dimension b3 replaces dimension b2.
5. This dimension allows for off-center lid, meniscus, and glass overrun.
6. Dimension Q shall be measured from the seating plane to the base plane.
7. Measure dimension S1 at all four corners.
8. N is the maximum number of terminal positions.
9. Dimensioning and tolerancing per ANSI Y14.5M - 1982.
10. Controlling dimension: INCH.

© Copyright Intersil Americas LLC 1998-2003. All Rights Reserved.
All trademarks and registered trademarks are the property of their respective owners.

For additional products, see www.intersil.com/en/products.html

Intersil products are manufactured, assembled and tested utilizing ISO9001 quality systems as noted in the quality certifications found at www.intersil.com/en/support/qualandreliability.html

Intersil products are sold by description only. Intersil may modify the circuit design and/or specifications of products at any time without notice, provided that such modification does not, in Intersil's sole judgment, affect the form, fit or function of the product. Accordingly, the reader is cautioned to verify that datasheets are current before placing orders. Information furnished by Intersil is believed to be accurate and reliable. However, no responsibility is assumed by Intersil or its subsidiaries for its use; nor for any infringements of patents or other rights of third parties which may result from its use. No license is granted by implication or otherwise under any patent or patent rights of Intersil or its subsidiaries.

For information regarding Intersil Corporation and its products, see www.intersil.com