

## High-Performance, Dual-Channel DC-DC Converter for Automotive Applications

### General Description

DA9132-A is a power management IC (PMIC) suitable for supplying CPUs, GPUs, DDR memory rails in single in-line pin package (SIPP) modules, vehicle infotainment systems, ADAS, automotive navigation, centre console and telematics.

DA9132-A integrates two single-phase buck converters, each phase requiring a small external 0.22  $\mu$ H inductor. Each buck is capable of delivering up to 3 A output current at a 0.3 V to 1.9 V output voltage range. The 2.8 V to 5.5 V input voltage range is suitable for a wide variety of low-voltage systems.

With remote sensing, the DA9132-A guarantees the highest accuracy and supports multiple PCB routing scenarios without loss of performance.

The pass devices are fully integrated, so no external FETs or Schottky diodes are needed.

A programmable soft start-up can be enabled, which limits the inrush current from the input node and secures a slope-controlled rail activation.

The dynamic voltage control (DVC) supports adaptive adjustment of the supply voltage dependent on the processor load, via either a direct register write using the communication interface (I<sup>2</sup>C-compatible) or with a programmable input pin.

A configurable GPI allows multiple I<sup>2</sup>C address selection for multiple instances of DA9132-A in the same application.

DA9132-A has integrated over-temperature and over-current protection for increased system reliability, without the need for external sensing components.

### Key Features

- 2.8 V to 5.5 V input voltage
- 0.3 V to 1.9 V output voltage
- Up to 3 A output current per channel
- 4 MHz nominal switching frequency
- Dual-channel
- 220 nH inductor per channel
- 20  $\mu$ F output capacitor
- $\pm 1$  % output voltage accuracy (static)
- $\pm 5$  % load transient (dynamic)
- Programmable GPIOs
- Programmable soft startup
- I<sup>2</sup>C-compatible interface (FM+)
- Voltage, current, and temperature supervision
- 24-pin FCQFN package, wettable flanks (nom. 3.3 mm x 4.8 mm)
- 218 mm<sup>2</sup> total solution area
- -40 °C to +105 °C ambient temperature range
- AEC-Q100 Grade 2 qualified for Automotive applications

### Benefits

- High Efficiency buck converters deliver outstanding thermal performance
- Fully integrated switching FET's means no external FETs or Schottky diodes are required
- Remote sensing guarantees the highest accuracy and supports multiple PCB routing scenarios without loss of performance.
- Fully programmable soft-start limits the inrush current from the input to give a slope-controlled output voltage.
- Dynamic voltage control (DVC) enables adaptive adjustment of the device output voltage depending on the load. This increases efficiency when the downstream circuitry enters low power or idle mode, resulting in power savings.
- Configurable GPIOs support a range of features including I<sup>2</sup>C, DVC and Power-Good indicator.

---

## High-Performance, Dual-Channel DC-DC Converter for Automotive Applications

- Optimized BoM cost and footprint: Each output requires a very small inductor and capacitor delivering parts and cost savings
- Cycle by cycle current limiting for superior over-current protection

## Applications

- Vehicle infotainment systems
- ADAS
- Automotive navigation
- Automotive center console
- Automotive cluster
- Telematics
- SIPP modules (SoC, DRAM)
- SoC/FPGA based, high performance, automotive Electronic Control unit (ECU) requiring efficient, high current, power delivery

High-Performance, Dual-Channel DC-DC Converter for Automotive Applications

System Diagrams

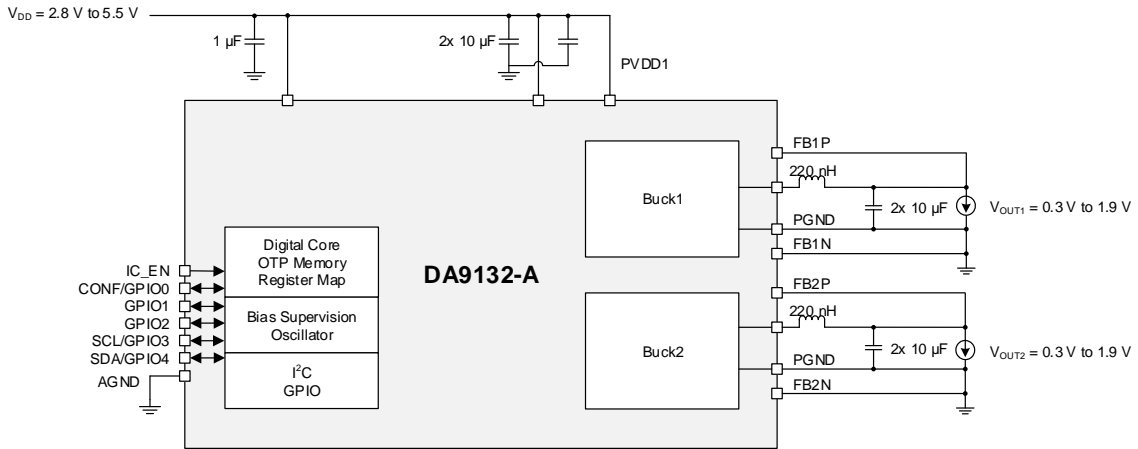

Figure 1: Simplified Schematic Diagram

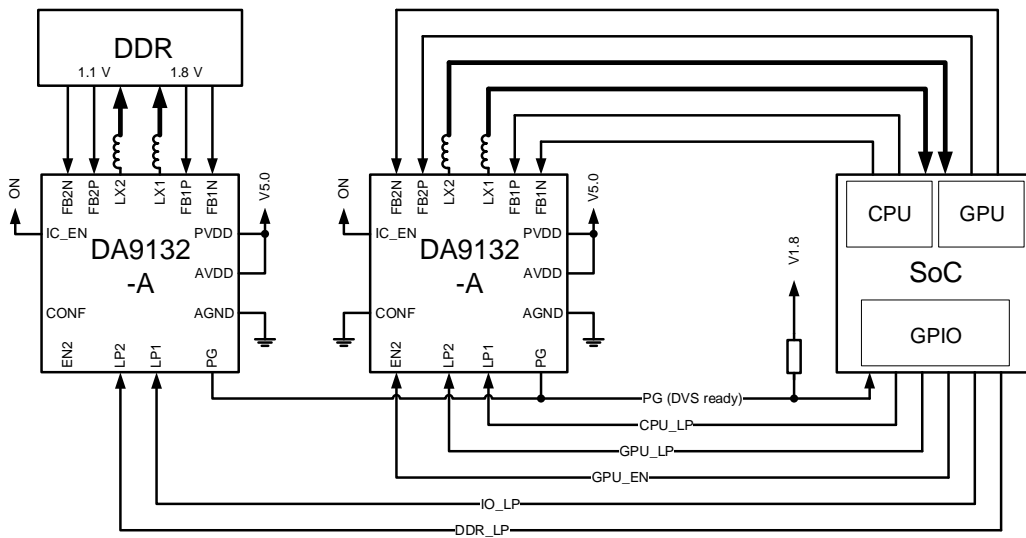

Figure 2: Typical Application Diagram (Port Control)

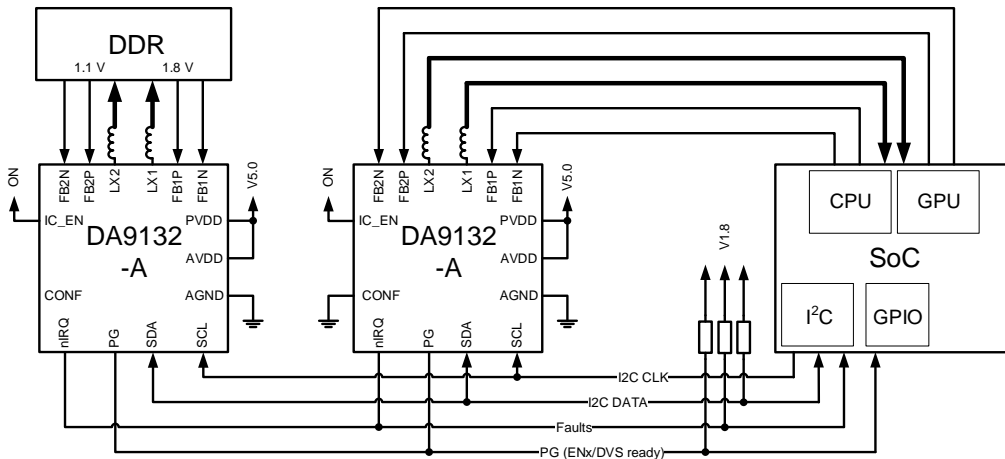

Figure 3: Typical Application Diagram (I<sup>2</sup>C Control)

## High-Performance, Dual-Channel DC-DC Converter for Automotive Applications

### Contents

<b>General Description</b> .....	<b>1</b>
<b>Key Features</b> .....	<b>1</b>
<b>Benefits</b> .....	<b>1</b>
<b>Applications</b> .....	<b>2</b>
<b>System Diagrams</b> .....	<b>3</b>
<b>Contents</b> .....	<b>4</b>
<b>Table of Figures</b> .....	<b>5</b>
<b>Table of Tables</b> .....	<b>5</b>
<b>1 Terms and Definitions</b> .....	<b>7</b>
<b>2 Pinout</b> .....	<b>8</b>
<b>3 Characteristics</b> .....	<b>9</b>
3.1 Absolute Maximum Ratings .....	9
3.2 Recommended Operating Conditions.....	9
3.3 Thermal Characteristics .....	10
3.3.1 Thermal Ratings .....	10
3.3.2 Power Dissipation .....	10
3.3.3 ESD Characteristics.....	11
3.4 Buck Characteristics .....	12
3.5 Performance and Supervision Characteristics.....	14
3.6 Digital I/O Characteristics.....	15
3.7 Timing Characteristics.....	16
3.8 Typical Performance .....	17
<b>4 Functional Description</b> .....	<b>18</b>
4.1 DC-DC Buck Converter.....	18
4.1.1 Switching Frequency .....	18
4.1.2 Operation Modes and Phase Selection .....	18
4.1.3 Output Voltage Selection .....	19
4.1.4 Soft Start-Up and Shutdown.....	19
4.1.5 Current Limit .....	19
4.1.6 Resistive Divider .....	20
4.1.7 Thermal Protection .....	21
4.2 Internal Circuits .....	22
4.2.1 IC_EN/Chip Enable/Disable.....	22
4.2.2 nIRQ/Interrupt.....	22
4.2.3 GPIO .....	26
4.3 Operating Modes.....	29
4.3.1 ON.....	29
4.3.2 OFF.....	29
4.4 I <sup>2</sup> C Communication .....	29
4.4.1 I <sup>2</sup> C Protocol.....	29
<b>5 Register Definitions</b> .....	<b>31</b>
5.1 Register Map.....	31
5.1.1 System.....	33

## High-Performance, Dual-Channel DC-DC Converter for Automotive Applications

5.1.2	Buck1 .....	43
5.1.3	Buck2 .....	47
5.1.4	Serialization .....	51
<b>6</b>	<b>Package Information .....</b>	<b>52</b>
6.1	Package Outlines .....	52
6.2	Package Marking .....	53
6.3	Moisture Sensitivity Level.....	53
6.4	Soldering Information .....	53
<b>7</b>	<b>Ordering Information .....</b>	<b>54</b>
<b>8</b>	<b>Application Information .....</b>	<b>55</b>
8.1	Capacitor Selection .....	55
8.2	Inductor Selection .....	55

## Table of Figures

Figure 1: Simplified Schematic Diagram .....	3
Figure 2: Typical Application Diagram (Port Control) .....	3
Figure 3: Typical Application Diagram (I <sup>2</sup> C Control).....	3
Figure 4: DA9132-A Pinout Diagram (Bottom View) .....	8
Figure 5: Power Derating Curve .....	10
Figure 6: DA9132-A Efficiency, V <sub>OUT</sub> = 1.0 V, PWM Mode .....	17
Figure 7: DA9132-A Efficiency, V <sub>OUT</sub> = 1.0 V, Auto Mode .....	17
Figure 8: Buck Output Voltage Control Concept .....	19
Figure 9: Resistive Divider.....	20
Figure 10: Thermal Protection Operation .....	21
Figure 11: Interrupt Operation Example .....	24
Figure 12: Interrupt Operation Example 2 .....	25
Figure 13: Interrupt Operation Example 3 .....	25
Figure 14: Interrupt Operation Example 4 .....	25
Figure 15: Power-Good (PG) and System Good (SG) .....	27
Figure 16: I <sup>2</sup> C START and STOP Condition Timing.....	30
Figure 17: I <sup>2</sup> C Byte Write (SDA Line) .....	30
Figure 18: I <sup>2</sup> C Byte Read (SDA Line) Examples .....	30
Figure 19: Package Outline Drawing.....	52

## Table of Tables

Table 1: Pin Description .....	8
Table 2: Pin Type Definition .....	9
Table 3: Absolute Maximum Ratings.....	9
Table 4: Recommended Operating Conditions .....	9
Table 5: Package Ratings .....	10
Table 6: Power Dissipation.....	10
Table 7: ESD Characteristics .....	11
Table 8: Buck Electrical Characteristics .....	12
Table 9: Electrical Characteristics .....	14
Table 10: Digital I/O Electrical Characteristics .....	15
Table 11: I <sup>2</sup> C Electrical Characteristics .....	16
Table 12: Thermal Protection Control Registers .....	21
Table 13: Interrupt List.....	22
Table 14: Interrupt Registers Except for Power-Good Status .....	23
Table 15: Interrupt Registers for Power-Good, System Good, and Temp Warning Status .....	24

## High-Performance, Dual-Channel DC-DC Converter for Automotive Applications

Table 16: GPIO Pin Assignment .....	26
Table 17: GPIO Function Configuration .....	26
Table 18: GPIO0-Configurable Registers when CONF_EN = 1 .....	28
Table 19: Register Map .....	31
Table 20: SYS_STATUS_0 (0x0001) .....	33
Table 21: SYS_STATUS_1 (0x0002) .....	33
Table 22: SYS_STATUS_2 (0x0003) .....	33
Table 23: SYS_EVENT_0 (0x0004) .....	33
Table 24: SYS_EVENT_1 (0x0005) .....	33
Table 25: SYS_EVENT_2 (0x0006) .....	34
Table 26: SYS_MASK_0 (0x0007) .....	34
Table 27: SYS_MASK_1 (0x0008) .....	34
Table 28: SYS_MASK_2 (0x0009) .....	34
Table 29: SYS_MASK_3 (0x000A) .....	35
Table 30: SYS_CONFIG_0 (0x000B) .....	35
Table 31: SYS_CONFIG_1 (0x000C) .....	36
Table 32: SYS_CONFIG_2 (0x000D) .....	37
Table 33: SYS_CONFIG_3 (0x000E) .....	38
Table 34: SYS_GPIO0_0 (0x0010) .....	38
Table 35: SYS_GPIO0_1 (0x0011) .....	39
Table 36: SYS_GPIO1_0 (0x0012) .....	39
Table 37: SYS_GPIO1_1 (0x0013) .....	40
Table 38: SYS_GPIO2_0 (0x0014) .....	41
Table 39: SYS_GPIO2_1 (0x0015) .....	42
Table 40: BUCK_BUCK1_0 (0x0020) .....	43
Table 41: BUCK_BUCK1_1 (0x0021) .....	43
Table 42: BUCK_BUCK1_2 (0x0022) .....	44
Table 43: BUCK_BUCK1_3 (0x0023) .....	45
Table 44: BUCK_BUCK1_4 (0x0024) .....	45
Table 45: BUCK_BUCK1_5 (0x0025) .....	46
Table 46: BUCK_BUCK1_6 (0x0026) .....	46
Table 47: BUCK_BUCK2_0 (0x0028) .....	47
Table 48: BUCK_BUCK2_1 (0x0029) .....	47
Table 49: BUCK_BUCK2_2 (0x002A) .....	48
Table 50: BUCK_BUCK2_3 (0x002B) .....	49
Table 51: BUCK_BUCK2_4 (0x002C) .....	49
Table 52: BUCK_BUCK2_5 (0x002D) .....	50
Table 53: BUCK_BUCK2_6 (0x002E) .....	50
Table 54: OTP_DEVICE_ID (0x0048) .....	51
Table 55: OTP_VARIANT_ID (0x0049) .....	51
Table 56: OTP_CUSTOMER_ID (0x004A) .....	51
Table 57: OTP_CONFIG_ID (0x004B) .....	51
Table 58: MSL Classification .....	53
Table 59: Ordering Information .....	54
Table 60: Recommended Automotive Grade Capacitor Types .....	55
Table 61: Recommended Inductor Types .....	55

---

## High-Performance, Dual-Channel DC-DC Converter for Automotive Applications

### 1 Terms and Definitions

ATE	Automated Test Equipment
CPU	Central Processing Unit
DDR	Dual Data Rate
DVC	Dynamic Voltage Control
FET	Field Effect Transistor
FM+	Fast Mode Plus
GBD	Guaranteed By Design
GBQ	Guaranteed By Qualification
GBSPC	Guaranteed By Statistical Process Characterization
GPI	General Purpose Input
GPIO	General Purpose Input/Output
GPU	Graphics Processing Unit
IC	Integrated Circuit
HW	Hardware
OTP	One Time Programmable
PCB	Printed Circuit Board
PRS	Product Requirements Specification
SCL	Serial Clock
SDA	Serial Data
SIPP	Single In-Line Pin Package
SW	Software

High-Performance, Dual-Channel DC-DC Converter for Automotive Applications

2 Pinout

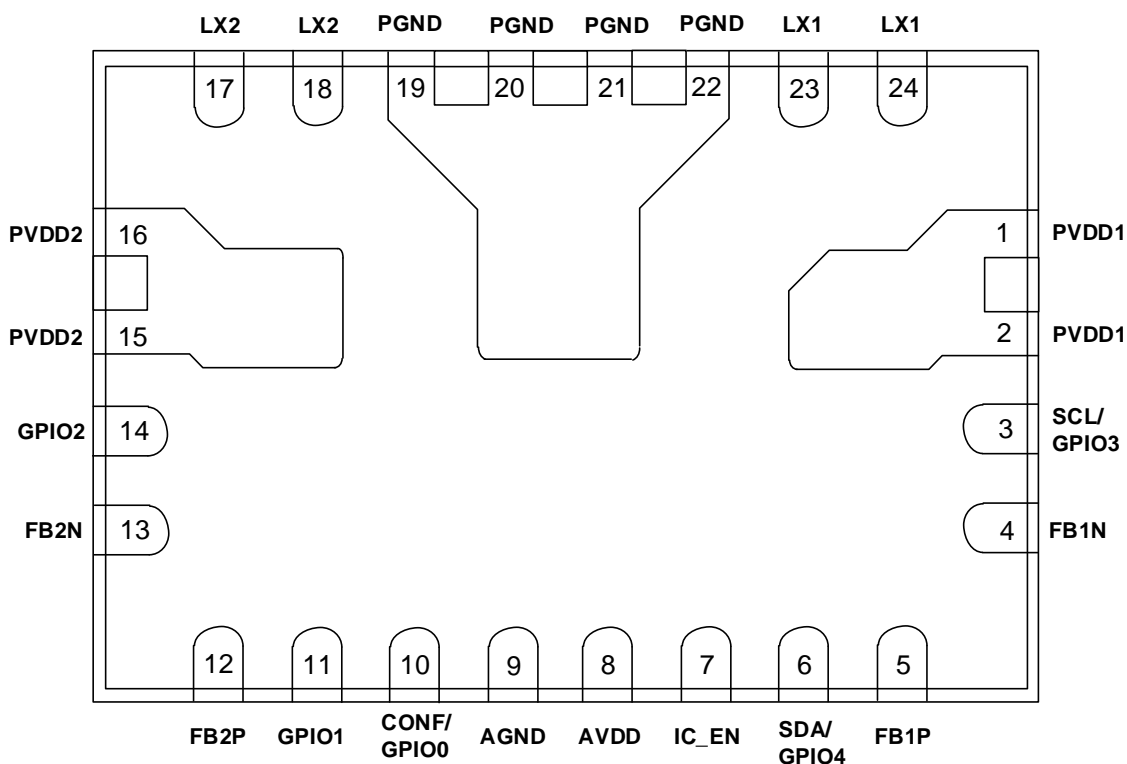

Figure 4: DA9132-A Pinout Diagram (Bottom View)

Table 1: Pin Description

Pin #	Pin Name	Type (Table 2)	Drive (mA)	Description
1, 2	PVDD1	PS	5000	Supply for Ch1
3	SCL/GPIO3	DIO	15	SCL
4	FB1N	AI	10	Negative feedback for Ch1
5	FB1P	AI	10	Positive feedback for Ch1
6	SDA/GPIO4	DIO	15	SDA
7	IC_EN	DI	10	IC enable.
8	AVDD	PS	10	Analog supply
9	AGND	PS	10	Analog ground
10	CONF/GPIO0	DIO	10	GPIO
11	GPIO1	DIO	10	GPIO
12	FB2P	AI	10	Positive feedback for Ch2
13	FB2N	AI	10	Negative feedback for Ch2
14	GPIO2	DIO	10	GPIO
15, 16	PVDD2	PS	5000	Supply for Ch2
17, 18	LX2	AO	5000	Buck output of Ch2
19, 20, 21, 22	PGND	PS	5000	Power ground
23, 24	LX1	AO	5000	Buck output of Ch1



## High-Performance, Dual-Channel DC-DC Converter for Automotive Applications

**Table 2: Pin Type Definition**

Pin Type	Description	Pin Type	Description
DI	Digital input	AI	Analog input
DIO	Digital input/output	AO	Analog output
PS	Power supply		

### 3 Characteristics

#### 3.1 Absolute Maximum Ratings

Stresses beyond those listed under Absolute Maximum Ratings may cause permanent damage to the device. These are stress ratings only, so functional operation of the device at these or any other conditions beyond those indicated in the operational sections of the specification are not implied. Exposure to Absolute Maximum Rating conditions for extended periods may affect device reliability.

**Table 3: Absolute Maximum Ratings**

Parameter	Description	Conditions	Min	Max	Unit
T <sub>STG</sub>	Storage temperature		-65	150	°C
T <sub>J</sub>	Junction temperature		-40	150	°C
V <sub>SYS</sub>	System supply voltage		-0.3	6.0	V
V <sub>PIN</sub>	Voltage on pins		-0.3	6.0	V

#### 3.2 Recommended Operating Conditions

**Table 4: Recommended Operating Conditions**

Parameter	Description (Note 2)	Conditions (Note 1)	Min	Typ	Max	Unit
V <sub>SYS</sub>	System supply voltage		2.8		5.5	V
V <sub>PIN</sub>	Voltage on pins		-0.3		V <sub>SYS</sub> + 0.3	V
T <sub>J</sub>	Junction temperature		-40		125	°C
T <sub>A</sub>	Ambient temperature		-40		105	°C

**Note 1** Within the specified limits, a lifetime of 10 years is guaranteed. If operating outside of these recommended conditions, please consult with Dialog Semiconductor.

**Note 2** V<sub>SYS</sub>, V<sub>IN</sub>, P<sub>VDD</sub>, A<sub>VDD</sub> should be connected together. The pin names are different for routing purposes.

## High-Performance, Dual-Channel DC-DC Converter for Automotive Applications

### 3.3 Thermal Characteristics

#### 3.3.1 Thermal Ratings

**Table 5: Package Ratings**

Parameter	Description	Conditions	Min	Typ	Max	Unit
$\theta_{JA}$	Package thermal resistance	Note 1		21.21		°C/W
$\theta_{JB}$	Thermal resistance junction to board	Note 1		12.37		°C/W
$\theta_{JC}$	Thermal resistance junction to case	Without PCB		32		°C/W

**Note 1** Obtained from package thermal simulations, JEDEC 2S2P four layer board (76.2 mm x 114 mm x 1.6 mm), 70  $\mu\text{m}$  (2 oz) copper thickness power planes, 35  $\mu\text{m}$  (1 oz) copper thickness signal layer traces, natural convection (still air), see Section 6.1.

#### 3.3.2 Power Dissipation

**Table 6: Power Dissipation**

Parameter	Description	Conditions	Min	Typ	Max	Unit
$P_{D\_Twarn}$	Power dissipation	@105 °C ambient, $T_{J\_WARN}$		0.94		W
$P_{D\_Tcrit}$	Power dissipation	@105 °C ambient, $T_{CRIT}$	1.41	1.65		W
$P_{D\_70}$	Power dissipation	@70°C ambient		2.43		W

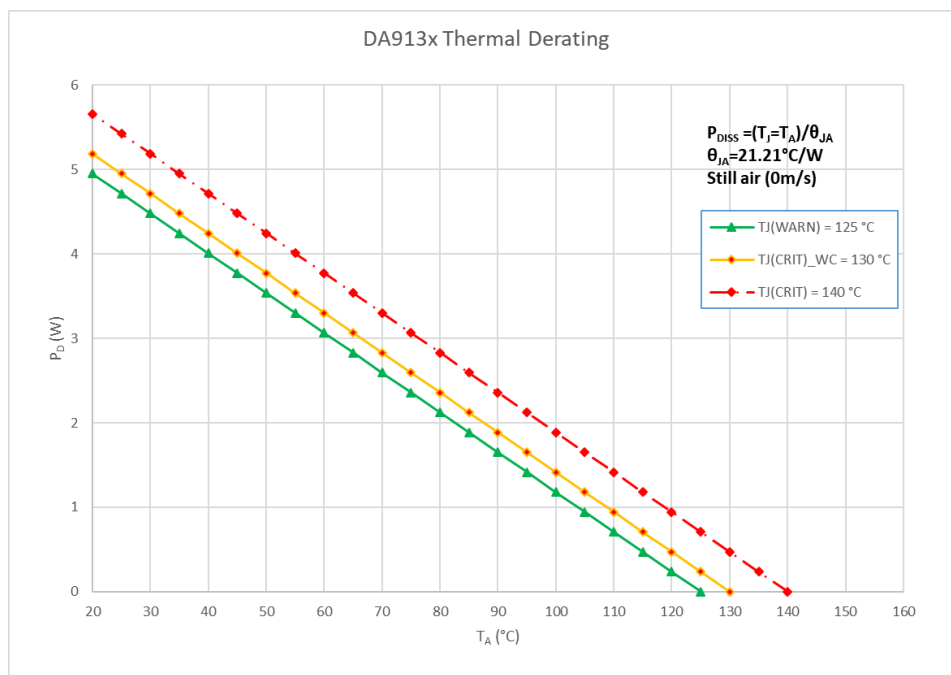

**Figure 5: Power Derating Curve**

## High-Performance, Dual-Channel DC-DC Converter for Automotive Applications

### 3.3.3 ESD Characteristics

**Table 7: ESD Characteristics**

Parameter	Description	Conditions	Value	Unit
V <sub>ESD_HBM</sub>	ESD protection, human body model (HBM)		2	kV
V <sub>ESD_CDM</sub>	Maximum ESD protection	Charged device model (CDM)	500	V

## High-Performance, Dual-Channel DC-DC Converter for Automotive Applications

### 3.4 Buck Characteristics

Unless otherwise noted, the following is valid for  $T_J = -40\text{ }^\circ\text{C}$  to  $+125\text{ }^\circ\text{C}$ ,  $V_{SYS} = 2.8\text{ V}$  to  $5.5\text{ V}$ .

**Table 8: Buck Electrical Characteristics**

Parameter	Description	Conditions	Min	Typ	Max	Unit
<b>External Electrical Conditions</b>						
$V_{IN}$	Input voltage	$V_{IN} = V_{SYS}$	2.8		5.5	V
$C_{OUT}$	Output capacitance, including voltage and temperature coefficient		-40 %	20	+30 %	$\mu\text{F}$
$ESR_{COUT}$	Output capacitor series resistance	$f > 100\text{ kHz}$		1		$\text{m}\Omega$
L	Inductor value, including current and temperature dependence		-50 %	220	+20 %	nH
$DCR_L$	Inductor DC resistance			8	13	$\text{m}\Omega$
<b>Electrical Performance</b>						
$V_{OUT}$	Output voltage, configurable in 10 mV steps	$I_{OUT} = 0\text{ mA}$ to $I_{MAX}$ at $25\text{ }^\circ\text{C}$ ambient $2.8\text{ V} < V_{OUT} + 1\text{ V} < V_{IN} \leq 5.5\text{ V}$	0.3		1.9	V
$I_{LIM}$	Current limit, configurable per phase <a href="#">Note 1</a> <a href="#">Note 2</a>	$CHx\_ILIM = 0100$	-20 %	5	+20 %	A
$I_{MAX}$	Output current <a href="#">Note 3</a>	$V_{IN} \geq V_{OUT} + 1.0\text{ V}$	3			A
$V_{OUT\_ACC}$	Output voltage accuracy, including static line and load regulation	$V_{OUT} < 1\text{ V}$	-10		10	mV
$V_{OUT\_ACC}$	Output voltage accuracy, including static line and load regulation	$V_{OUT} \geq 1\text{ V}$	-1		1	%
$V_{THR\_PG\_HYS}$	Power-good voltage threshold hysteresis	$V_{OUT} = V_{THR\_PG\_DWN}$	60	80	100	mV
$V_{THR\_PG\_DWN}$	Power-good voltage threshold for falling	$V_{OUT} = V_{BUCK}$	-160	-130	-80	mV
$V_{THR\_HV}$	High $V_{OUT}$ voltage threshold	$V_{OUT} = V_{BUCK}$	100	150	200	mV
$V_{OUT\_TR\_LINE}$	Line transient response	$V_{IN} = 3\text{ V}$ to $3.6\text{ V}$ $I_{OUT} = 0.5 * I_{MAX}$ $dt = 10\text{ }\mu\text{s}$		15		mV
$f_{SW}$	Switching frequency			4		MHz

## High-Performance, Dual-Channel DC-DC Converter for Automotive Applications

Parameter	Description	Conditions	Min	Typ	Max	Unit
t <sub>ON_MIN</sub>	Minimum turn-on pulse 0 % duty is also supported		5	7	11	ns
t <sub>BUCK_EN</sub>	Turn-on time	CH <sub>x</sub> _EN = high			20	μs
R <sub>PD</sub>	Output pull-down resistance at the LX node, see CH <sub>x</sub> _PD_DIS	V <sub>IN</sub> = 3.7 V V <sub>OUT</sub> = 0.5 V	145	150	161	Ω
R <sub>ON_P MOS</sub>	On resistance of switching PMOS	V <sub>IN</sub> = 3.7 V	17	25	37	mΩ
R <sub>ON_N MOS</sub>	On resistance of switching NMOS	V <sub>IN</sub> = 3.7 V	6	10	16	mΩ
<b>PWM Mode</b>						
I <sub>Q_PWM</sub>	Quiescent current	V <sub>IN</sub> = 3.7 V No load		16		mA
η <sub>PWM</sub>	Efficiency	V <sub>IN</sub> = 3.6 V V <sub>OUT</sub> = 1 V I <sub>OUT</sub> = 10 % (I <sub>MAX</sub> ) to 80 % (I <sub>MAX</sub> )		85		%
<b>AUTO Mode</b>						
V <sub>OUT_TR_LD</sub>	Load transient response	V <sub>OUT</sub> = 1 V I <sub>OUT</sub> = 1.25 to 3.75 A at 25 °C ambient dI/dt = 2.5 A/μs	-30		55	mV
<b>PFM Mode</b>						
I <sub>Q_PFM</sub>	Quiescent current in PFM	1-phase V <sub>IN</sub> = 3.7 V No load No switching		88		μA
η <sub>PFM</sub>	Efficiency	V <sub>IN</sub> = 3.6 V V <sub>OUT</sub> = 1 V I <sub>OUT</sub> = 10 mA		80		%

**Note 1** t<sub>ON</sub> > 40 ns

**Note 2** The value is configured by OTP and should not be modified while the buck is active.

**Note 3** For short durations to meet peak current requirements, I<sub>OUT</sub> can be operated at up to 10 % higher than the specified maximum operating condition. The part should not be operated in this mode for extended periods and is not guaranteed for continuous operation.

## High-Performance, Dual-Channel DC-DC Converter for Automotive Applications

### 3.5 Performance and Supervision Characteristics

**Table 9: Electrical Characteristics**

Parameter	Description	Conditions	Min	Typ	Max	Unit
<b>Electrical Performance</b>						
V <sub>THR_POR</sub>	Power-on-reset threshold	Threshold for AVDD falling		2.1	2.25	V
V <sub>THR_POR_HYS</sub>	Power-on-reset hysteresis			200		mV
T <sub>WARN</sub>	Thermal warning temperature threshold		115	125	135	°C
T <sub>CRIT</sub>	Thermal shutdown temperature threshold		130	140	150	°C
I <sub>IN_OFF</sub>	Supply current	OFF state T <sub>A</sub> = 27 °C IC_EN = 0		0.1	1	μA
I <sub>IN_ON</sub>	Supply current	ON state T <sub>A</sub> = 27 °C IC_EN = 1 Buck off	5	10	20	μA

## High-Performance, Dual-Channel DC-DC Converter for Automotive Applications

### 3.6 Digital I/O Characteristics

**Table 10: Digital I/O Electrical Characteristics**

Parameter	Description	Conditions	Min	Typ	Max	Unit
<b>Electrical Performance</b>						
V <sub>IH_EN</sub>	Input high voltage, IC enable		1.2		AVDD	V
V <sub>IL_EN</sub>	Input low voltage, IC enable				0.4	V
t <sub>IC_EN</sub>	IC enable time				1000	μs
V <sub>IH_GPIO_SCL_SDA</sub>	Input high voltage GPIO, SCL, SDA		1.2		AVDD	V
V <sub>IL_GPIO_SCL_SDA</sub>	Input low voltage GPIO, SCL, SDA				0.4	V
V <sub>OH_GPIO</sub>	Output high voltage GPIO	Push-pull mode I <sub>OUT</sub> = 1 mA	0.8*AVDD		AVDD	V
V <sub>OL_GPIO</sub>	Output low voltage GPIO	Push-pull mode I <sub>OUT</sub> = 1 mA			0.2*AVDD	V
V <sub>OL_SDA</sub>	Output low voltage SDA	I <sub>OUT</sub> = 3 mA		0.24		V
R <sub>PD</sub>	GPIO pull-down resistor	V <sub>sys</sub> = 3.7 V Note 1	9	15	24	kΩ
R <sub>PU</sub>	GPIO pull-up resistor	V <sub>sys</sub> = 3.7 V Note 1	28	45	70	kΩ

**Note 1** Resistance may have greater variation, depending on voltage and temperature.

## High-Performance, Dual-Channel DC-DC Converter for Automotive Applications

### 3.7 Timing Characteristics

**Table 11: I2C Electrical Characteristics**

Parameter	Description	Conditions	Min	Typ	Max	Unit
<b>Electrical Performance</b>						
t <sub>BUS</sub>	Bus free time between a STOP and START condition		0.5			μs
C <sub>BUS</sub>	Bus line capacitive load				150	pF
f <sub>SCL</sub>	SCL clock frequency		20 Note 1		1000	kHz
t <sub>LO_SCL</sub>	SCL low time		0.5			μs
t <sub>HI_SCL</sub>	SCL high time		0.26			μs
t <sub>RISE</sub>	SCL and SDA rise time	Requirement for input			1000	ns
t <sub>FALL</sub>	SCL and SDA fall time	Requirement for input			300	ns
t <sub>SETUP_START</sub>	Start condition setup time		0.26			μs
t <sub>HOLD_START</sub>	Start condition hold time		0.26			μs
t <sub>SETUP_STOP</sub>	Stop condition setup time		0.26			μs
t <sub>DATA</sub>	Data valid time				0.45	μs
t <sub>DATA_ACK</sub>	Data valid acknowledge time				0.45	μs
t <sub>SETUP_DATA</sub>	Data setup time		50			ns
t <sub>HOLD_DATA</sub>	Data hold time		0			ns

**Note 1** Minimum clock frequency is limited to 20 kHz if I2C\_TIMEOUT is enabled



High-Performance, Dual-Channel DC-DC Converter for Automotive Applications

3.8 Typical Performance

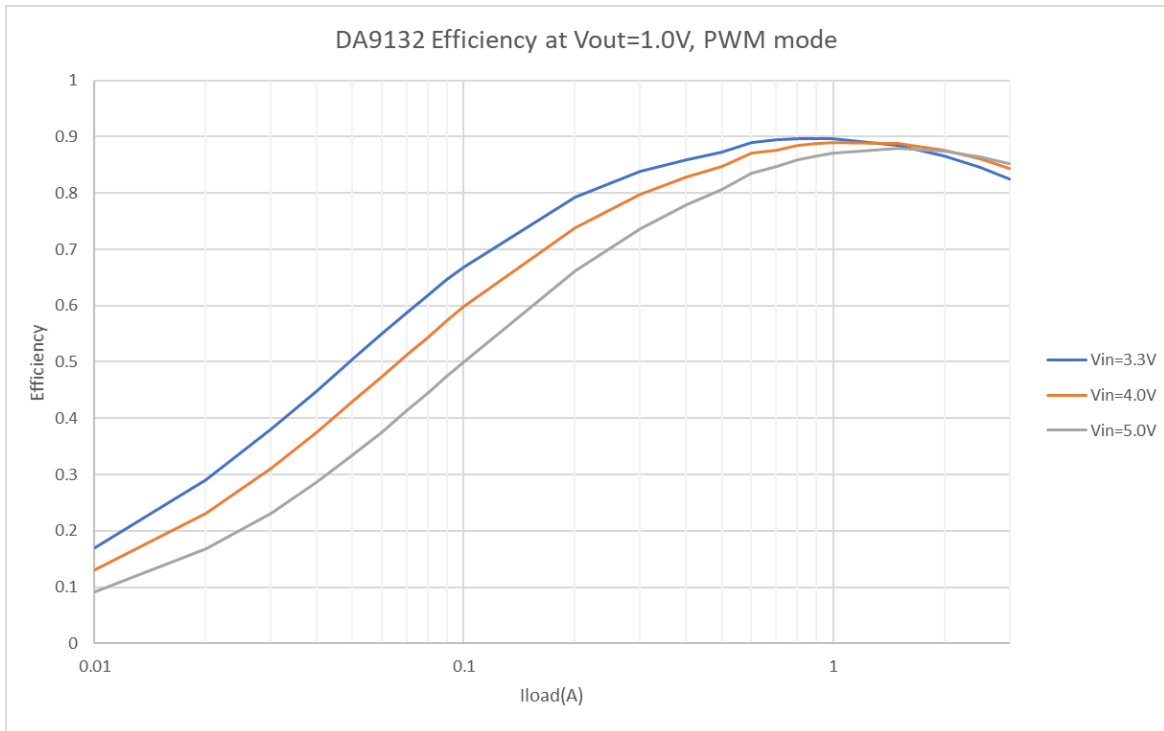

Figure 6: DA9132-A Efficiency, V<sub>OUT</sub> = 1.0 V, PWM Mode

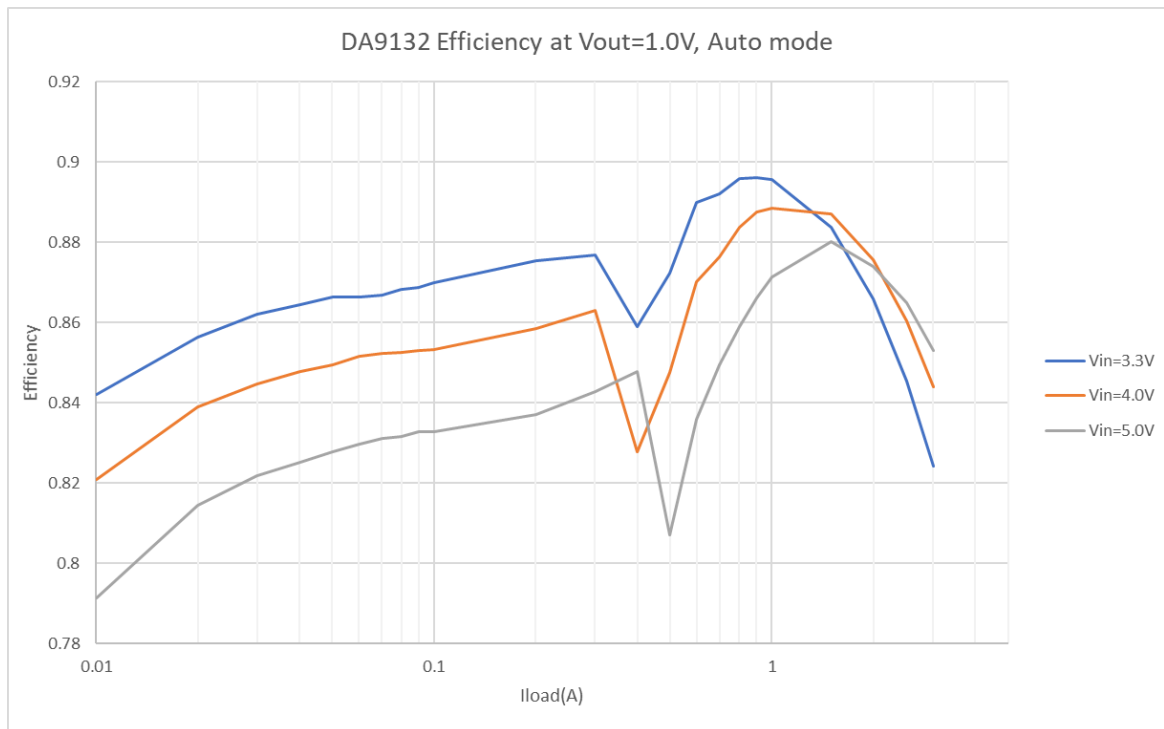

Figure 7: DA9132-A Efficiency, V<sub>OUT</sub> = 1.0 V, Auto Mode

## High-Performance, Dual-Channel DC-DC Converter for Automotive Applications

### 4 Functional Description

#### 4.1 DC-DC Buck Converter

DA9132-A contains two buck converters, Buck1 and Buck2, each capable of delivering up to 3 A output current at a 0.3 V to 1.9 V output voltage range.

Buck1 and Buck2 have two voltage registers each. One defines the normal output voltage, while the other offers an alternative retention voltage. In this way, different application power modes can easily be supported. The voltage selection can be operated either via GPI or via control interface to guarantee the maximum flexibility according to the specific host processor status in the application.

When a buck is enabled, its output voltage is monitored and a power-good signal indicates that the buck output voltage has reached a level higher than the  $V_{THR\_PG\_HYS}$  threshold. The power-good status is lost when the voltage drops below  $V_{THR\_PG\_DWN}$  or increases above  $V_{THR\_HV}$ . For each of the buck converters the status of the power-good indicator can be read back via I<sup>2</sup>C from the PG1 and PG2 status bits. It can be also individually assigned to any of the GPIOs by setting the GPIO mode registers to either PG1 or PG2 output.

The buck converters are capable of supporting DVC transitions that occur when:

- the active and selected A- or B-voltage is updated to a new target value
- the voltage selection is changed from the A- to B-voltage (or B- to A-voltage) using CH<x>\_VSEL

The DVC controller operates in pulse width modulation (PWM) mode with synchronous rectification.

The slew rate of the DVC transition is individually programmed for each buck converter at 10 mV per 8  $\mu$ s, 4  $\mu$ s, 2  $\mu$ s, 1  $\mu$ s, or 0.5  $\mu$ s in register bits CH1\_SR\_DVC and CH2\_SR\_DVC.

A pull-down resistor (typically 150  $\Omega$ ) for each phase is always activated unless it is disabled by setting register bits CH<x>\_PD\_DIS to 1.

##### 4.1.1 Switching Frequency

The buck switching frequency, nominally 4 MHz, can be tuned using register bit OSC\_TUNE. The internal 8 MHz oscillator frequency is tuned in  $\pm 160$  kHz steps. This impacts the buck converter frequency in steps of 80 kHz and helps to mitigate possible disturbances to other high frequency systems in the application.

##### 4.1.2 Operation Modes and Phase Selection

The buck converters can operate in PWM and PFM modes. The operating mode is selected using register bits CH1\_<A or B>\_MODE and CH2\_<A or B>\_MODE.

If the automatic operation mode is selected on CH1\_<A or B>\_MODE or CH2\_<A or B>\_MODE, the buck converters automatically change between synchronous PWM mode and PFM depending on the load current. This improves the efficiency across the whole range of output load currents.

## High-Performance, Dual-Channel DC-DC Converter for Automotive Applications

### 4.1.3 Output Voltage Selection

The switching converter can be configured using the I<sup>2</sup>C interface.

For each buck converter two output voltages can be pre-configured in registers CH<x>\_<A or B>\_VOUT. The output voltage can be selected by either toggling register bit CH<x>\_VSEL or by re-programming the selected voltage control register. Both changes will result in ramped voltage transitions. After being enabled, the buck converter will, by default, use the register settings in CH<x>\_A\_VOUT unless the output voltage selection is configured via the GPI port.

Registers CH<1 and 2>\_VMAX limit the output voltage that can be set for each of the respective buck converters.

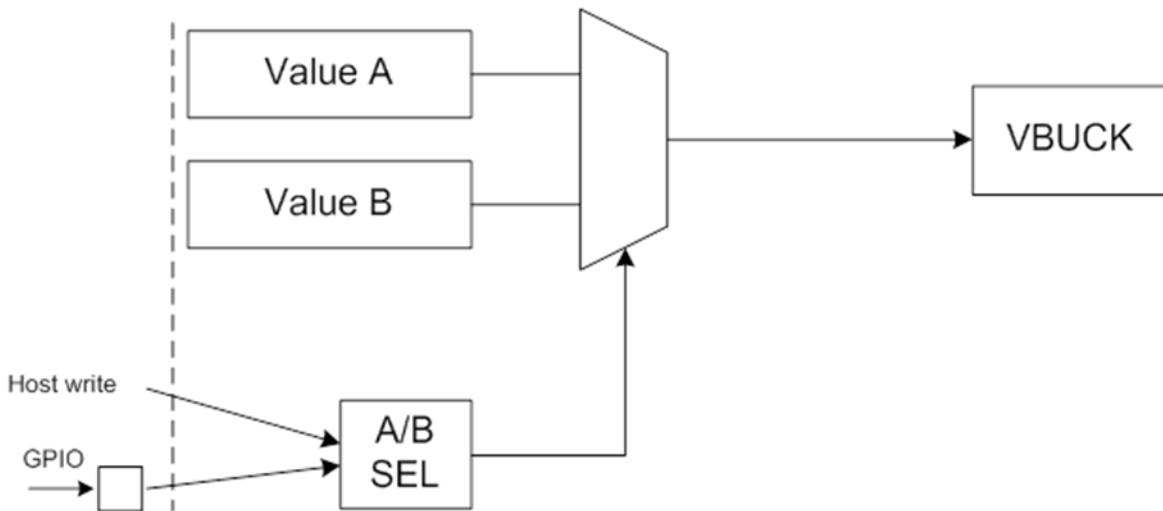

Figure 8: Buck Output Voltage Control Concept

### 4.1.4 Soft Start-Up and Shutdown

To limit in-rush current from VSYS, the buck converters can perform a soft-start after being enabled. The start-up behavior is a compromise between acceptable inrush current from the battery and turn-on time. Individual ramp times can be configured for each buck converter in registers CH<1 and 2>\_SR\_STARTUP respectively. Rates higher than 20 mV/μs may produce overshoot during the start-up phase, so they should be considered carefully.

A ramped power down can be selected in register bits CH<1 and 2>\_SR\_SHDN. When no ramp is selected (immediate power down), the output node will be discharged only by the pull-down resistor, if enabled in registers CH<1 and 2>\_PD\_DIS.

### 4.1.5 Current Limit

The integrated current limit protects the power stages and external coil from excessive current. The buck current limit should be configured to at least 40 % higher than the required maximum output current.

When the current limit is reached, each buck converter generates an event and an interrupt to the host processor unless the interrupt has been masked using register M\_OC<x> in SYS\_MASK\_1. Register bits OC\_DVC\_MASK is used to mask over-current events during DVC transitions.

## High-Performance, Dual-Channel DC-DC Converter for Automotive Applications

### 4.1.6 Resistive Divider

DA9132-A can support output voltages higher than 1.9 V using an external resistive divider shown in Figure 9.

To calculate the output voltage with an external divider, use the following equation

$$V_{OUT} = V_{SEL} \times \left(1 + \frac{R1}{R2}\right)$$

**Equation 1**

$V_{SEL}$  is the device buck output voltage setting.

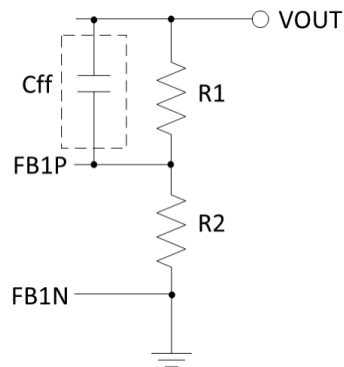

**Figure 9: Resistive Divider**

For example, to program the output voltage to 3.3 V, set  $V_{SEL}$  to 1.65 V, and use a 2.2 k $\Omega$  resistor for both R1 and R2, with  $C_{ff} = 1$  nF.

#### NOTE

The resistors need to be properly selected since the output voltage accuracy will be directly affected by any errors on the resistors. The voltage across FB1P and FB1N ( $V_{SEL}$ ) is guaranteed, but not the output voltage accuracy.



#### CAUTION

- The followings are important notes that need to be considered before using resistive divider on DA9132-A:
1. Please contact your region's Dialog representative when adopting the resistive divider technique. Dialog need to prepare a special OTP because incorrect OTP settings may result in a different output voltage than expected.
  2. The total resistance ( $R1+R2$ ) is less than 40 k $\Omega$ .
  3. It is recommended that the device is operated in PWM mode only.

## High-Performance, Dual-Channel DC-DC Converter for Automotive Applications

### 4.1.7 Thermal Protection

DA9132-A is protected from internal overheating by thermal shutdown.

There are two kinds of flags concerning thermal protection, thermal warning and thermal critical. The warning flag is asserted when  $T_J > T_{WARN}$  and the critical flag is asserted when  $T_J > T_{CRIT}$ . When the critical flag is asserted, Buck1 and Buck2 are shut down immediately.

**Table 12: Thermal Protection Control Registers**

Category	Register name	Description
Status	TEMP_WARN	Asserted as long as the thermal warning threshold is reached
	TEMP_CRIT	Asserted as long as the thermal shutdown threshold is reached
IRQ event	E_TEMP_WARN	TEMP_WARN caused event
	E_TEMP_CRIT	TEMP_CRIT caused event
IRQ mask	M_TEMP_WARN	TEMP_WARN event IRQ mask
	M_TEMP_CRIT	TEMP_CRIT event IRQ mask
	M_VR_HOT	TEMP_WARN status IRQ mask

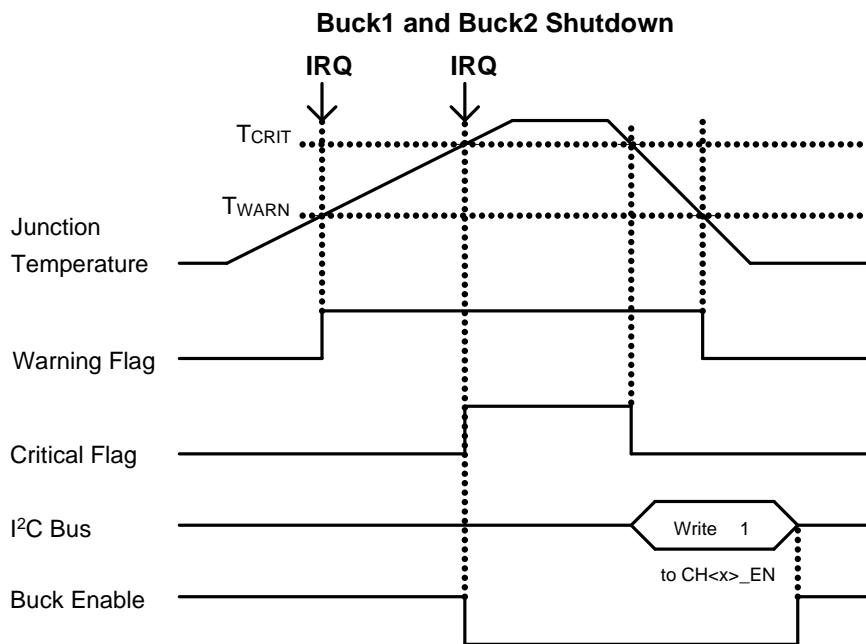

**Figure 10: Thermal Protection Operation**

## High-Performance, Dual-Channel DC-DC Converter for Automotive Applications

### 4.2 Internal Circuits

#### 4.2.1 IC\_EN/Chip Enable/Disable

IC\_EN is chip enable/disable control input. When IC\_EN = 0, all blocks except for low I<sub>Q</sub> POR are powered-down and buck output is pulled-down.

#### 4.2.2 nIRQ/Interrupt

The interrupt triggers events. Trigger conditions and control registers for each interrupt event are listed in [Table 13](#).

Some of these events are categorized as fault events and affect device operation (for example, buck disable), see [Section 4.1.7](#).

**Table 13: Interrupt List**

Name	Polarity (Note 1)	Trigger	IRQ Status Register	IRQ Mask Register	Deglitch Period
Thermal warning (event)	N	T <sub>J</sub> rising above T <sub>WARN</sub>	E_TEMP_WARN	M_TEMP_WARN	0 s
Thermal critical (event)	N	T <sub>J</sub> rising above T <sub>CRIT</sub>	E_TEMP_CRIT	M_TEMP_CRIT	0 s
System good (event)	P	Buck1 PG or Buck2 PG event	E_SG	M_SG	0 s
Buck1 power-good (event)	P	Buck1 V <sub>OUT</sub> is in power-good voltage range (not under- or over-voltage)	E_PG1	M_PG1	0 s
Buck2 power-good (event)	P	Buck2 V <sub>OUT</sub> is in power-good voltage range (not under- or over-voltage)	E_PG2	M_PG2	0 s
Buck1 over-voltage (event)	N	Buck1 V <sub>OUT</sub> rising above over-voltage threshold (target voltage + 150 mV)	E_OV1	M_OV1	Rise:8 μs Fall:8 μs
Buck2 over-voltage (event)	N	Buck2 V <sub>OUT</sub> rising above over-voltage threshold (target voltage + 150 mV)	E_OV2	M_OV2	Rise:8 μs Fall:8 μs
Buck1 under-voltage (event)	N	Buck1 V <sub>OUT</sub> falling below under-voltage threshold (target voltage - V <sub>TH_PG</sub> )	E_UV1	M_UV1	0 s
Buck2 under-voltage (event)	N	Buck2 V <sub>OUT</sub> falling below under-voltage threshold (target voltage - V <sub>TH_PG</sub> )	E_UV2	M_UV2	0 s
Buck1 over-current (event)	N	Buck1 current rising above over-current threshold	E_OC1	M_OC1	0 s

## High-Performance, Dual-Channel DC-DC Converter for Automotive Applications

Name	Polarity (Note 1)	Trigger	IRQ Status Register	IRQ Mask Register	Deglintch Period
Buck2 over-current (event)	N	Buck2 current rising above over-current threshold	E_OC2	M_OC2	0 s
Buck1 power-good (status) (Note 2)	P	Buck1 V <sub>OUT</sub> is in power-good voltage range (not under- or over-voltage)	PG1	M_PG1_STAT (Note 3)	0 s
Buck2 power-good (status) (Note 2)	P	Buck2 V <sub>OUT</sub> is in power-good voltage range (not under- or over-voltage)	PG2	M_PG2_STAT (Note 3)	0 s
System good (status) (Note 2)	P	Buck1 PG or Buck2 PG is active	SG	M_SG_STAT (Note 3)	0 s
Thermal warning (status) (Note 2)	N	T <sub>J</sub> rising above T <sub>WARN</sub>	TEMP_WARN	M_VR_HOT (Note 3)	0 s
GPIO0 change (event)	N	Detect GPIO0 change for active trigger selected GPIO0_TRIG register	E_GPIO0	M_GPIO0	100 μs/ 1 ms/ 10 ms/ 100 ms
GPIO1 change (event)	N	Detect GPIO1 change for active trigger selected GPIO1_TRIG register	E_GPIO1	M_GPIO1	
GPIO2 change (event)	N	Detect GPIO2 change for active trigger selected GPIO2_TRIG register	E_GPIO2	M_GPIO2	

**Note 1** Polarity at the source of the flag: P = active-high, N = active-low.  
General rule is: normal system state is high, and abnormal system state is low (for example, PG = high means power-good, TEMP\_CRIT = low when TEMP critical state).

**Note 2** Interrupt outputs the status as is. I<sup>2</sup>C write is not required for interrupt clear.

**Note 3** OTP load value defined by CONF pin setting if CONF\_EN = 1.

**Table 14: Interrupt Registers Except for Power-Good Status**

Register	Description
E_<name>	Read-only interrupt event register 0: No interrupt 1: Interrupt occurred <b>Cleared after being written to I<sup>2</sup>C.</b> Set until IRQ is removed.
M_<name>	Interrupt mask register 0: Not masked 1: Masked. No IRQ signal sent. Event register (E_<name>) is updated.

## High-Performance, Dual-Channel DC-DC Converter for Automotive Applications

**Table 15: Interrupt Registers for Power-Good, System Good, and Temp Warning Status**

Register	Description
PG<x>	Buck<x> power-good status. Asserted as long as the buck<x> output voltage is in range (under-voltage threshold < buck output voltage < over-voltage threshold) 0: Not power-good 1: Power-good
M_PG<x>_STAT	Power-good status interrupt mask register 0: Not masked 1: Masked. No IRQ signal sent. Power-good status register (PG<x>) is updated
SG	System good status 0: Not system good 1: System good
M_SG_STAT	System good status (SG) interrupt mask register 0: Not masked 1: Masked. No IRQ signal sent. System good status register (SG) is updated
TEMP_WARN	Asserted as long as the thermal warning threshold ( $T_{WARN}$ ) is reached 0: Junction temperature is below $T_{WARN}$ 1: Junction temperature is above $T_{WARN}$
M_VR_HOT	Temperature warning status (TEMP_WARN) interrupt mask register 0: Not masked 1: Masked. No IRQ signal sent. Temperature warning status register (TEMP_WARN) is updated

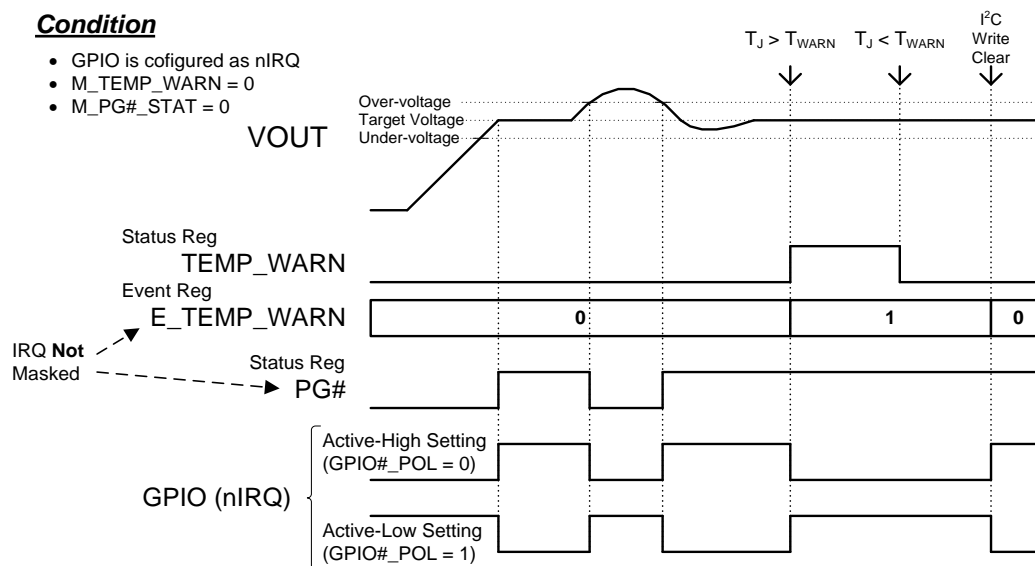

**Figure 11: Interrupt Operation Example**



## High-Performance, Dual-Channel DC-DC Converter for Automotive Applications

**Condition**

- GPIO is configured as nIRQ
- **M\_VR\_HOT = 0**
- M\_PG1\_STAT = 0
- M\_PG2\_STAT = 0

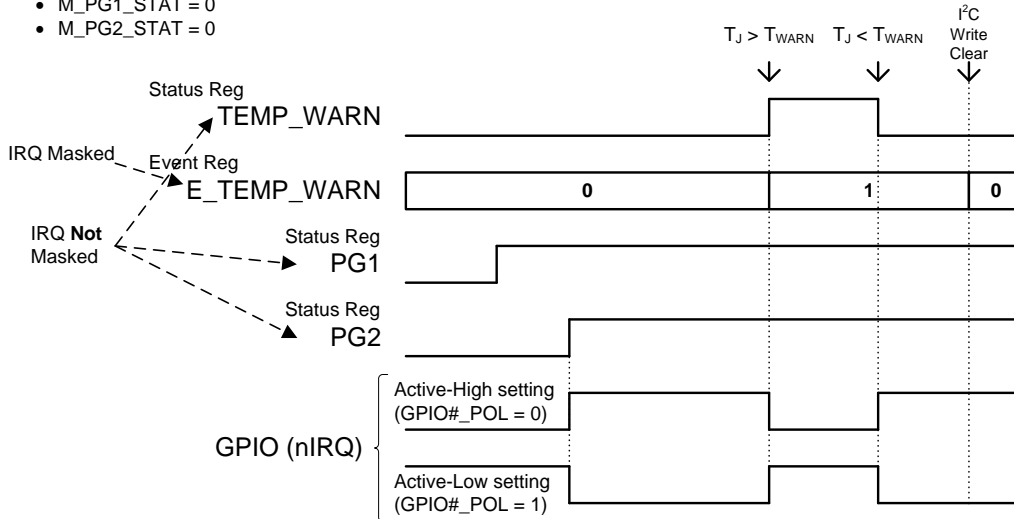

Figure 12: Interrupt Operation Example 2

**Condition**

- GPIO is configured as nIRQ
- **M\_SG = 0**

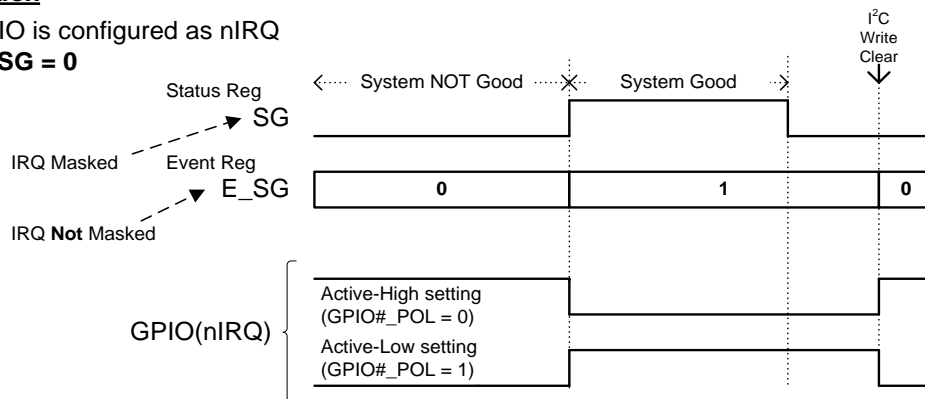

Figure 13: Interrupt Operation Example 3

**Condition**

- GPIO is configured as nIRQ
- **M\_SG\_STAT = 0**

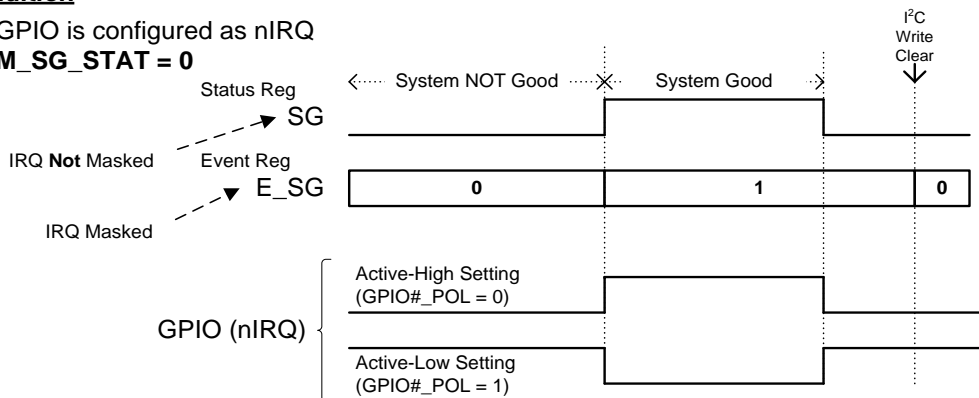

Figure 14: Interrupt Operation Example 4

## High-Performance, Dual-Channel DC-DC Converter for Automotive Applications

### 4.2.3 GPIO

#### 4.2.3.1 GPIO Pin Assignment

The DA9132-A provides up to five GPIO pins, three if the I<sup>2</sup>C is enabled, see Table 16. These registers are OTP programmable. When CONF\_EN = 1 GPIO0 can be used for chip configuration.

Any register settings for GPIO3 and GPIO4 are ignored and GPIO3 and GPIO4 function as SCL and SDA respectively if I2C\_EN = 1.

**Table 16: GPIO Pin Assignment**

OTP Option		GPIO Pin					Available GPIOs
I2C_EN	CONF_EN	CONF/ GPIO0	GPIO1	GPIO2	SCL/ GPIO3	SDA/ GPIO4	
1'b0	1'b0	GPIO0	GPIO1	GPIO2	GPIO3	GPIO4	5
	1'b1	CONF	GPIO1	GPIO2	GPIO3	GPIO4	4
1'b1	1'b0	GPIO0	GPIO1	GPIO2	SCL	SDA	3
	1'b1	CONF	GPIO1	GPIO2	SCL	SDA	2

#### 4.2.3.2 GPIO Function

The GPIOs pins are configurable as the following functions in register GPIO<x>\_MODE (x = 0 to 4):

- Buck1 enable input (EN1)
- Buck2 enable input (EN2)
- Buck1 and Buck2 enable input (EN1 & EN2)
- Buck1 DVC control input (DVC1)
- Buck2 DVC control input (DVC2)
- Buck1 and Buck2 DVC control input (DVC1 & DVC2)
- Buck1 and Buck2 OTP setting reload input (RELOAD)
- Buck1 power-good output (PG1)
- Buck2 power-good output (PG2)
- Buck1 and Buck2 power-good output (PG1 & PG2)
- System good output (SG)
- Interrupt output (nIRQ)

**Table 17: GPIO Function Configuration**

GPIO<x>_MODE[3:0]	Function	IO Condition
4'h0	GPIO disable	HiZ
4'h1	EN1	In
4'h2	EN2	In
4'h3	EN1 & EN2	In
4'h4	DVC1	In
4'h5	DVC2	In
4'h6	DVC1 & DVC2	In
4'h7	RELOAD	In
4'h8	PG1	Out
4'h9	PG2	Out

High-Performance, Dual-Channel DC-DC Converter for Automotive Applications

GPIO<x>_MODE[3:0]	Function	IO Condition
4'hA	PG1 & PG2	Out
4'hB	SG	Out
4'hC	nIRQ	Out
4'hD	Reserved	HiZ
4'hE	Low level	Out
4'hF	High level	Out

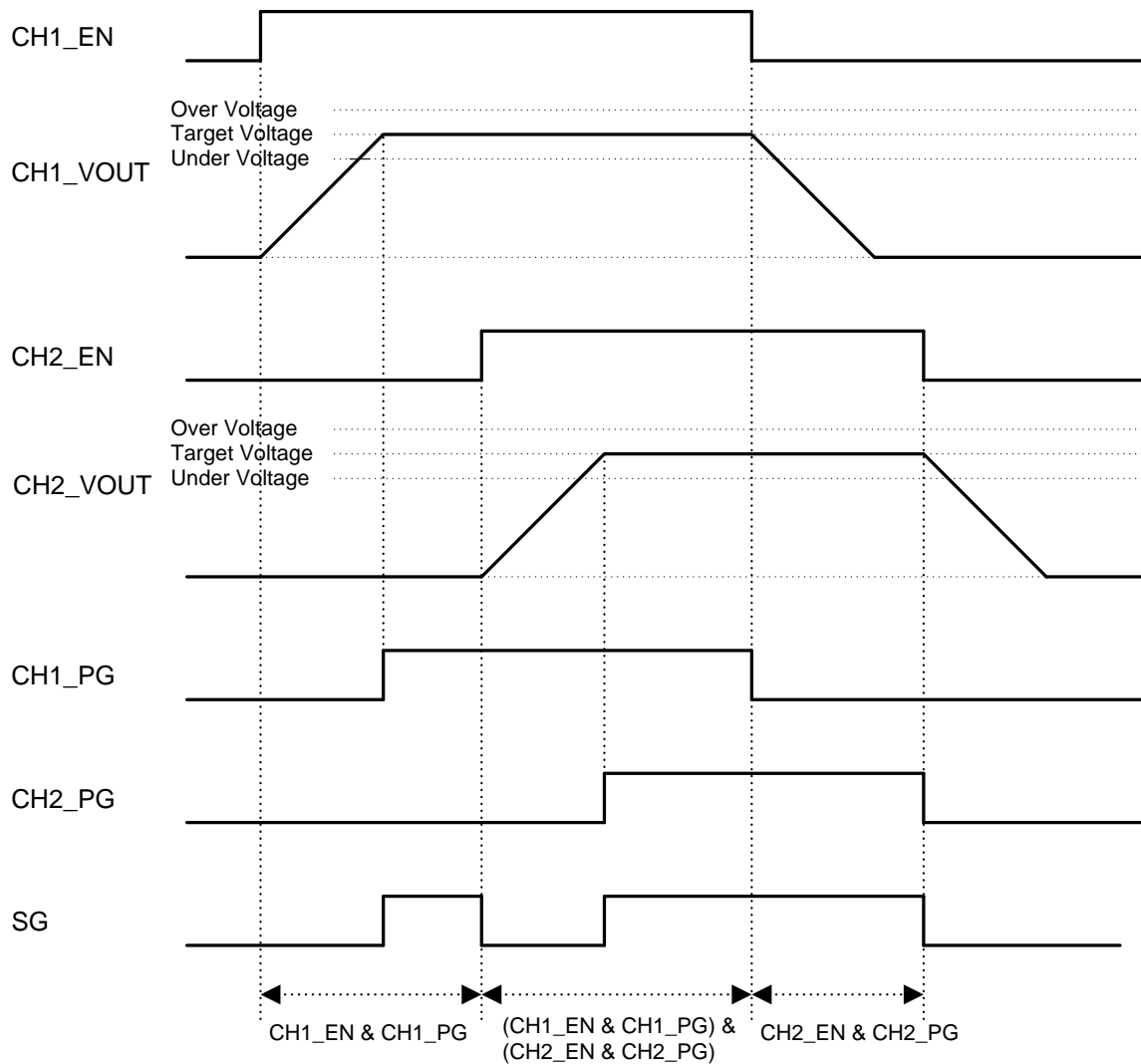

Figure 15: Power-Good (PG) and System Good (SG)

## High-Performance, Dual-Channel DC-DC Converter for Automotive Applications

### 4.2.3.3 Chip Configuration Select (CONF)

GPIO0 functions as chip configuration select (CONF) input when CONF\_EN = 1.

Three different chip configurations can be selected according to the CONF pin level, whether it is HIGH, LOW, or Hi-Z. [Table 18](#) lists the device configurations can be modified if CONF\_EN = 1.

**Table 18: GPIO0-Configurable Registers when CONF\_EN = 1**

Register Name	Description
IF_SLAVE_ADDR[6:0]	I <sup>2</sup> C slave address
CH1_A_MODE[1:0]	CH1_A Operation mode select
CH1_B_MODE[1:0]	CH1_B Operation mode select
CH1_VSEL	CH1 output voltage and operation selection
CH1_EN	CH1 enable
CH1_A_VOUT[7:0]	CH1 output voltage setting A
CH1_B_VOUT[7:0]	CH1 output voltage setting B
CH2_A_MODE[1:0]	CH2_A Operation mode select
CH2_B_MODE[1:0]	CH2_B Operation mode select
CH2_VSEL	CH2 output voltage and operation selection
CH2_EN	CH2 enable
CH2_A_VOUT[7:0]	CH2 output voltage setting A
CH2_B_VOUT[7:0]	CH2 output voltage setting B
M_PG1_STAT	IRQ mask setting for CH1 power-good status
M_PG2_STAT	IRQ mask setting for CH2 power-good status
M_SG_STAT	IRQ mask setting for system good status
M_VR_HOT	IRQ mask setting for temp warning status
CH1_EN_DLY[3:0]	Delay setting for CH1 enable
CH1_DIS_DLY[3:0]	Delay setting for CH1 disable
CH2_EN_DLY[3:0]	Delay setting for CH2 enable
CH2_DIS_DLY[3:0]	Delay setting for CH2 disable
GPIO1_MODE[3:0]	GPIO1 mode setting
GPIO2_MODE[3:0]	GPIO2 mode setting
GPIO1_OBUF	GPIO1 output buffer select
GPIO2_OBUF	GPIO2 output buffer select
GPIO1_TRIG[1:0]	GPIO1 input trigger select
GPIO1_POL	GPIO1 polarity select
GPIO1_PUPD	GPIO1 pull-up/pull-down enable
GPIO1_DEB[1:0]	GPIO1 input debounce time setting
GPIO1_DEB_RISE	GPIO1 input debounce rising edge enable
GPIO1_DEB_FALL	GPIO1 input debounce falling edge enable
GPIO2_TRIG[1:0]	GPIO2 input trigger select
GPIO2_POL	GPIO2 polarity select
GPIO2_PUPD	GPIO2 pull-up/pull-down enable

## High-Performance, Dual-Channel DC-DC Converter for Automotive Applications

Register Name	Description
GPIO2_DEB[1:0]	GPIO2 input debounce time setting
GPIO2_DEB_RISE	GPIO2 input debounce rising edge enable
GPIO2_DEB_FALL	GPIO2 input debounce falling edge enable

### 4.3 Operating Modes

#### 4.3.1 ON

DA9132-A is ON when the IC\_EN port is higher than  $V_{IH\_EN}$  and the supply voltage is higher than  $V_{THR\_POR}$ . Once enabled, the host processor can start communicating with DA9132-A using the control interface, after the  $t_{IC\_EN}$  delay.

#### 4.3.2 OFF

DA9132-A is OFF when the IC\_EN port is lower than  $V_{IL\_EN}$ . In OFF, the bucks are always disabled and LX nodes are pulled down by (typically 150  $\Omega$ ) internal pull-down resistors.

### 4.4 I<sup>2</sup>C Communication

All features of DA9132-A can be controlled with the I<sup>2</sup>C interface which is enabled or disabled in register I2C\_EN.

I2C_EN	Description
0	I <sup>2</sup> C disable: SCL/GPIO3 and SDA/GPIO4 pins can be used as GPIO
1	I <sup>2</sup> C enable: SCL/GPIO3 and SDA/GPIO4 pins are used as I <sup>2</sup> C clock input and I <sup>2</sup> C data input/output.

GPIO3 functions as the I<sup>2</sup>C clock and GPIO4 carries all the power manager bidirectional I<sup>2</sup>C data. The I<sup>2</sup>C interface is open-drain supporting multiple devices on a single line. The bus lines have to be pulled high by external pull-up resistors (2 k $\Omega$  to 20 k $\Omega$ ). The standard frequency of the I<sup>2</sup>C bus is 1 MHz in fast-mode plus (FM+), 400 kHz in fast-mode, or 100 kHz in standard mode.

#### 4.4.1 I<sup>2</sup>C Protocol

All data is transmitted across the I<sup>2</sup>C bus in eight-bit groups. To send a bit, the SDA line is driven towards the intended state while the SCL is low (a low SDA indicates a zero bit). Once the SDA has settled, the SCL line is brought high and then low. This pulse on SCL clocks the SDA bit into the receiver's shift register.

A two-byte serial protocol is used containing one byte for address and one byte data. Data and address transfer are transmitted MSB first for both read and write operations. All transmissions begin with the START condition from the master while the bus is in idle state (the bus is free). It is initiated by a high to low transition on the SDA line while the SCL is in the high state (a STOP condition is indicated by a low to high transition on the SDA line while the SCL is in the high state).

## High-Performance, Dual-Channel DC-DC Converter for Automotive Applications

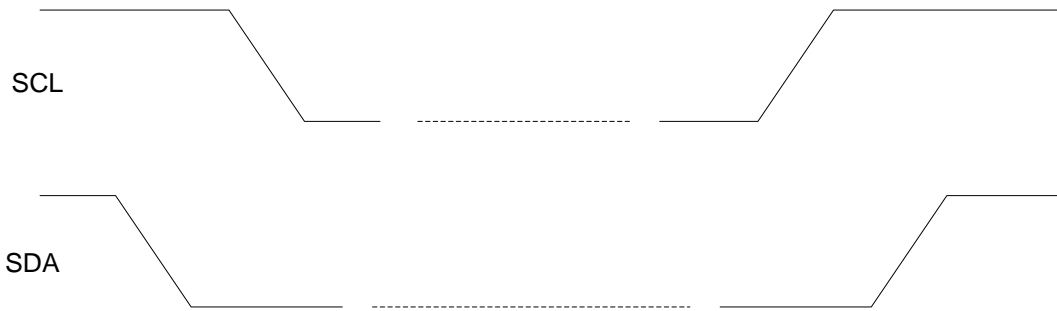

**Figure 16: I<sup>2</sup>C START and STOP Condition Timing**

The I<sup>2</sup>C bus is monitored for a valid slave address whenever the interface is enabled. It responds immediately when it receives its own slave address. The acknowledge is done by pulling the SDA line low during the following clock cycle (white blocks marked with A in Figure 17 and Figure 18).

The protocol for a register write from master to slave consists of a START condition, a slave address with read/write bit, and the eight-bit register address followed by eight bits of data, terminated by a STOP condition. DA9132-A responds to all bytes with acknowledge (A), see Figure 17.

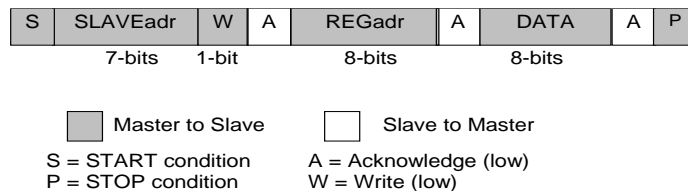

**Figure 17: I<sup>2</sup>C Byte Write (SDA Line)**

When the host reads data from a register it first has to write to DA9132-A with the target register address and then read from DA9132-A with a repeated START, or alternatively a second START, condition. After receiving the data, the host sends no acknowledge (A\*) and terminates the transmission with a STOP condition, see Figure 18.

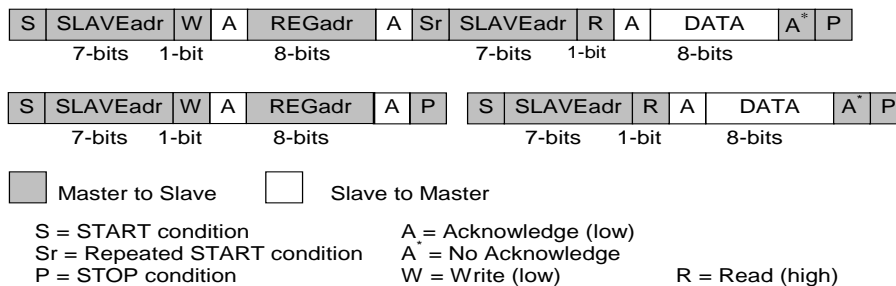

**Figure 18: I<sup>2</sup>C Byte Read (SDA Line) Examples**

## High-Performance, Dual-Channel DC-DC Converter for Automotive Applications

### 5 Register Definitions

#### 5.1 Register Map

Table 19: Register Map

Addr	Register	7	6	5	4	3	2	1	0
<b>System Module</b>									
<b>System</b>									
0x0001	<a href="#">SYS_STATUS_0</a>	Reserved	Reserved	Reserved	Reserved	Reserved	SG	TEMP_CRIT	TEMP_WARN
0x0002	<a href="#">SYS_STATUS_1</a>	PG2	OV2	UV2	OC2	PG1	OV1	UV1	OC1
0x0003	<a href="#">SYS_STATUS_2</a>	Reserved	Reserved	Reserved	Reserved	Reserved	GPIO2	GPIO1	GPIO0
0x0004	<a href="#">SYS_EVENT_0</a>	Reserved	Reserved	Reserved	Reserved	Reserved	E_SG	E_TEMP_CRIT	E_TEMP_WARN
0x0005	<a href="#">SYS_EVENT_1</a>	E_PG2	E_OV2	E_UV2	E_OC2	E_PG1	E_OV1	E_UV1	E_OC1
0x0006	<a href="#">SYS_EVENT_2</a>	Reserved	Reserved	Reserved	Reserved	Reserved	E_GPIO2	E_GPIO1	E_GPIO0
0x0007	<a href="#">SYS_MASK_0</a>	Reserved	Reserved	Reserved	Reserved	Reserved	M_SG	M_TEMP_CRIT	M_TEMP_WARN
0x0008	<a href="#">SYS_MASK_1</a>	M_PG2	M_OV2	M_UV2	M_OC2	M_PG1	M_OV1	M_UV1	M_OC1
0x0009	<a href="#">SYS_MASK_2</a>	Reserved	Reserved	Reserved	Reserved	Reserved	M_GPIO2	M_GPIO1	M_GPIO0
0x000A	<a href="#">SYS_MASK_3</a>	Reserved	Reserved	Reserved	Reserved	M_VR_HOT	M_SG_STAT	M_PG2_STAT	M_PG1_STAT
0x000B	<a href="#">SYS_CONFIG_0</a>	CH1_DIS_DLY<3:0>				CH1_EN_DLY<3:0>			
0x000C	<a href="#">SYS_CONFIG_1</a>	CH2_DIS_DLY<3:0>				CH2_EN_DLY<3:0>			
0x000D	<a href="#">SYS_CONFIG_2</a>	Reserved	OC_LATCHOFF<1:0>		OC_DVC_MASK	PG_DVC_MASK<1:0>		Reserved	Reserved
0x000E	<a href="#">SYS_CONFIG_3</a>	Reserved	OSC_TUNE<2:0>			Reserved	Reserved	I2C_TIMEOUT	Reserved
0x0010	<a href="#">SYS_GPIO0_0</a>	Reserved	Reserved	Reserved	GPIO0_MODE<3:0>				GPIO0_OBUF
0x0011	<a href="#">SYS_GPIO0_1</a>	GPIO0_DEB_FALL	GPIO0_DEB_RISE	GPIO0_DEB<1:0>		GPIO0_PUPD	GPIO0_PO L	GPIO0_TRIG<1:0>	
0x0012	<a href="#">SYS_GPIO1_0</a>	Reserved	Reserved	Reserved	GPIO1_MODE<3:0>				GPIO1_OBUF
0x0013	<a href="#">SYS_GPIO1_1</a>	GPIO1_DEB_FALL	GPIO1_DEB_RISE	GPIO1_DEB<1:0>		GPIO1_PUPD	GPIO1_PO L	GPIO1_TRIG<1:0>	
0x0014	<a href="#">SYS_GPIO2_0</a>	Reserved	Reserved	Reserved	GPIO2_MODE<3:0>				GPIO2_OBUF
0x0015	<a href="#">SYS_GPIO2_1</a>	GPIO2_DEB_FALL	GPIO2_DEB_RISE	GPIO2_DEB<1:0>		GPIO2_PUPD	GPIO2_PO L	GPIO2_TRIG<1:0>	

## High-Performance, Dual-Channel DC-DC Converter for Automotive Applications

Addr	Register	7	6	5	4	3	2	1	0
<b>Buck Control</b>									
<b>Buck1</b>									
0x0020	BUCK_BUCK1_0	Reserved	CH1_SR_DVC_DWN<2:0>			CH1_SR_DVC_UP<2:0>			CH1_EN
0x0021	BUCK_BUCK1_1	Reserved	CH1_SR_SHDN<2:0>			CH1_SR_STARTUP<2:0>			CH1_PD_DIS
0x0022	BUCK_BUCK1_2	Reserved	Reserved	Reserved	Reserved	CH1_ILIM<3:0>			
0x0023	BUCK_BUCK1_3	CH1_VMAX<7:0>							
0x0024	BUCK_BUCK1_4	Reserved	Reserved	Reserved	CH1_VSE L	CH1_B_MODE<1:0>		CH1_A_MODE<1:0>	
0x0025	BUCK_BUCK1_5	CH1_A_VOUT<7:0>							
0x0026	BUCK_BUCK1_6	CH1_B_VOUT<7:0>							
<b>Buck2</b>									
0x0028	BUCK_BUCK2_0	Reserved	CH2_SR_DVC_DWN<2:0>			CH2_SR_DVC_UP<2:0>			CH2_EN
0x0029	BUCK_BUCK2_1	Reserved	CH2_SR_SHDN<2:0>			CH2_SR_STARTUP<2:0>			CH2_PD_DIS
0x002A	BUCK_BUCK2_2	Reserved	Reserved	Reserved	Reserved	CH2_ILIM<3:0>			
0x002B	BUCK_BUCK2_3	CH2_VMAX<7:0>							
0x002C	BUCK_BUCK2_4	Reserved	Reserved	Reserved	CH2_VSE L	CH2_B_MODE<1:0>		CH2_A_MODE<1:0>	
0x002D	BUCK_BUCK1_5	CH2_A_VOUT<7:0>							
0x002E	BUCK_BUCK1_6	CH2_B_VOUT<7:0>							
<b>Serialization</b>									
0x0048	OTP_DEVICE_ID	DEV_ID<7:0>							
0x0049	OTP_VARIANT_ID	MRC<3:0>				VRC<3:0>			
0x004A	OTP_CUSTOMER_ID	CUST_ID<7:0>							
0x004B	OTP_CONFIG_ID	CONFIG_REV<7:0>							



## High-Performance, Dual-Channel DC-DC Converter for Automotive Applications

### 5.1.1 System

**Table 20: SYS\_STATUS\_0 (0x0001)**

Bit	Type	Symbol	Description
[2]	R	SG	Asserted as long as the output voltage of the enabled buck is in range
[1]	R	TEMP_CRIT	Asserted whilst the thermal shutdown threshold is exceeded
[0]	R	TEMP_WARN	Asserted whilst the thermal warning threshold is exceeded

**Table 21: SYS\_STATUS\_1 (0x0002)**

Bit	Type	Symbol	Description
[7]	R	PG2	Asserted whilst Buck2 output voltage is in range
[6]	R	OV2	Asserted whilst Buck2 output is over-voltage
[5]	R	UV2	Asserted whilst Buck2 output is under-voltage
[4]	R	OC2	Asserted whilst Buck2 output is over-current
[3]	R	PG1	Asserted whilst Buck1 output voltage is in range
[2]	R	OV1	Asserted whilst Buck1 output is over-voltage
[1]	R	UV1	Asserted whilst Buck1 output is under-voltage
[0]	R	OC1	Asserted whilst Buck1 output is over-current

**Table 22: SYS\_STATUS\_2 (0x0003)**

Bit	Type	Symbol	Description
[2]	R	GPIO2	GPIO2 status
[1]	R	GPIO1	GPIO1 status
[0]	R	GPIO0	GPIO0 status

**Table 23: SYS\_EVENT\_0 (0x0004)**

Bit	Type	Symbol	Description
[2]	R	E_SG	SG caused event. Write 1 to clear this bit after the event source has been released.
[1]	R	E_TEMP_CRIT	TEMP_CRIT event. Write 1 to clear this bit after the event source has been released.
[0]	R	E_TEMP_WARN	TEMP_WARN event. Write 1 to clear this bit after the event source has been released.

**Table 24: SYS\_EVENT\_1 (0x0005)**

Bit	Type	Symbol	Description
[7]	RW	E_PG2	PG2 caused event. Write 1 to clear this bit after the event source has been released.
[6]	RW	E_OV2	OV2 caused event. Write 1 to clear this bit after the event source has been released.
[5]	RW	E_UV2	UV2 caused event. Write 1 to clear this bit after the event source has been released.
[4]	RW	E_OC2	OC2 caused event. Write 1 to clear this bit after the event source has been released.

## High-Performance, Dual-Channel DC-DC Converter for Automotive Applications

Bit	Type	Symbol	Description
[3]	RW	E_PG1	PG1 caused event. Write 1 to clear this bit after the event source has been released.
[2]	RW	E_OV1	OV1 caused event. Write 1 to clear this bit after the event source has been released.
[1]	RW	E_UV1	UV1 caused event. Write 1 to clear this bit after the event source has been released.
[0]	RW	E_OC1	OC1 caused event. Write 1 to clear this bit after the event source has been released.

**Table 25: SYS\_EVENT\_2 (0x0006)**

Bit	Type	Symbol	Description
[2]	RW	E_GPIO2	GPIO2 event. Write 1 to clear this bit after the event source has been released.
[1]	RW	E_GPIO1	GPIO1 event. Write 1 to clear this bit after the event source has been released.
[0]	RW	E_GPIO0	GPIO0 event. Write 1 to clear this bit after the event source has been released.

**Table 26: SYS\_MASK\_0 (0x0007)**

Bit	Type	Symbol	Description
[2]	RW	M_SG	SG IRQ mask
[1]	RW	M_TEMP_CRIT	TEMP_CRIT IRQ mask
[0]	RW	M_TEMP_WARN	TEMP_WARN IRQ mask

**Table 27: SYS\_MASK\_1 (0x0008)**

Bit	Type	Symbol	Description
[7]	RW	M_PG2	PG2 event IRQ mask
[6]	RW	M_OV2	OV2 event IRQ mask
[5]	RW	M_UV2	UV2 event IRQ mask
[4]	RW	M_OC2	OC2 event IRQ mask
[3]	RW	M_PG1	PG1 event IRQ mask
[2]	RW	M_OV1	OV1 event IRQ mask
[1]	RW	M_UV1	UV1 event IRQ mask
[0]	RW	M_OC1	OC1 event IRQ mask

**Table 28: SYS\_MASK\_2 (0x0009)**

Bit	Type	Symbol	Description
[2]	RW	M_GPIO2	GPIO2 IRQ mask
[1]	RW	M_GPIO1	GPIO1 IRQ mask
[0]	RW	M_GPIO0	GPIO0 IRQ mask

## High-Performance, Dual-Channel DC-DC Converter for Automotive Applications

**Table 29: SYS\_MASK\_3 (0x000A)**

Bit	Type	Symbol	Description
[3]	RW	M_VR_HOT	Temp warning status IRQ mask. Initial value is determined by CONF pin setting at the start-up if CONF_EN = 1, see Section 4.2.3.3.
[2]	RW	M_SG_STAT	SG status IRQ mask. Initial value is determined by CONF pin setting at the start-up if CONF_EN = 1, see Section 4.2.3.3.
[1]	RW	M_PG2_STAT	PG2 status IRQ mask. Initial value is determined by CONF pin setting at the start-up if CONF_EN = 1, see Section 4.2.3.3.
[0]	RW	M_PG1_STAT	PG1 status IRQ mask. Initial value is determined by CONF pin setting at the start-up if CONF_EN = 1, see Section 4.2.3.3.

**Table 30: SYS\_CONFIG\_0 (0x000B)**

Bit	Type	Symbol	Description																																		
[7:4]	RW	CH1_DIS_DLY	<p>Delay for CH1 disable. Active with GPIO configured as EN1&amp;EN2 control and IC_EN control. Initial value is determined by CONF pin setting at the start-up in CONF_EN = 1</p> <table border="1"> <thead> <tr> <th>Value</th> <th>Description</th> </tr> </thead> <tbody> <tr><td>0x0</td><td>0</td></tr> <tr><td>0x1</td><td>1.0 ms</td></tr> <tr><td>0x2</td><td>2.0 ms</td></tr> <tr><td>0x3</td><td>3.0 ms</td></tr> <tr><td>0x4</td><td>4.0 ms</td></tr> <tr><td>0x5</td><td>5.0 ms</td></tr> <tr><td>0x6</td><td>6.0 ms</td></tr> <tr><td>0x7</td><td>7.0 ms</td></tr> <tr><td>0x8</td><td>8.0 ms</td></tr> <tr><td>0x9</td><td>9.0 ms</td></tr> <tr><td>0xA</td><td>10.0 ms</td></tr> <tr><td>0xB</td><td>11.0 ms</td></tr> <tr><td>0xC</td><td>12.0 ms</td></tr> <tr><td>0xD</td><td>13.0 ms</td></tr> <tr><td>0xE</td><td>14.0 ms</td></tr> <tr><td>0xF</td><td>15.0 ms</td></tr> </tbody> </table>	Value	Description	0x0	0	0x1	1.0 ms	0x2	2.0 ms	0x3	3.0 ms	0x4	4.0 ms	0x5	5.0 ms	0x6	6.0 ms	0x7	7.0 ms	0x8	8.0 ms	0x9	9.0 ms	0xA	10.0 ms	0xB	11.0 ms	0xC	12.0 ms	0xD	13.0 ms	0xE	14.0 ms	0xF	15.0 ms
Value	Description																																				
0x0	0																																				
0x1	1.0 ms																																				
0x2	2.0 ms																																				
0x3	3.0 ms																																				
0x4	4.0 ms																																				
0x5	5.0 ms																																				
0x6	6.0 ms																																				
0x7	7.0 ms																																				
0x8	8.0 ms																																				
0x9	9.0 ms																																				
0xA	10.0 ms																																				
0xB	11.0 ms																																				
0xC	12.0 ms																																				
0xD	13.0 ms																																				
0xE	14.0 ms																																				
0xF	15.0 ms																																				
[3:0]	RW	CH1_EN_DLY	<p>Delay for CH1 enable. Active with GPIO configured as EN1&amp;EN2 control and IC_EN control. Initial value is determined by CONF pin setting at the start-up in CONF_EN = 1</p> <table border="1"> <thead> <tr> <th>Value</th> <th>Description</th> </tr> </thead> <tbody> <tr><td>0x0</td><td>0</td></tr> <tr><td>0x1</td><td>0.5 ms</td></tr> <tr><td>0x2</td><td>1.0 ms</td></tr> <tr><td>0x3</td><td>1.5 ms</td></tr> </tbody> </table>	Value	Description	0x0	0	0x1	0.5 ms	0x2	1.0 ms	0x3	1.5 ms																								
Value	Description																																				
0x0	0																																				
0x1	0.5 ms																																				
0x2	1.0 ms																																				
0x3	1.5 ms																																				

## High-Performance, Dual-Channel DC-DC Converter for Automotive Applications

Bit	Type	Symbol	Description
			0x4      2.0 ms
			0x5      2.5 ms
			0x6      3.0 ms
			0x7      3.5 ms
			0x8      4.0 ms
			0x9      4.5 ms
			0xA      5.0 ms
			0xB      5.5 ms
			0xC      6.0 ms
			0xD      6.5 ms
			0xE      7.0 ms
			0xF      7.5 ms

**Table 31: SYS\_CONFIG\_1 (0x000C)**

Bit	Type	Symbol	Description
			Delay for CH2 disable. Active with GPIO configured as EN1&EN2 control and IC_EN control. Initial value is determined by CONF pin setting at the start-up in CONF_EN = 1
			<b>Value      Description</b>
			0x0      0
			0x1      1.0 ms
			0x2      2.0 ms
			0x3      3.0 ms
			0x4      4.0 ms
			0x5      5.0 ms
[7:4]	RW	CH2_DIS_DLY	0x6      6.0 ms
			0x7      7.0 ms
			0x8      8.0 ms
			0x9      9.0 ms
			0xA      10.0 ms
			0xB      11.0 ms
			0xC      12.0 ms
			0xD      13.0 ms
			0xE      14.0 ms
			0xF      15.0 ms
			Delay for CH2 enable. Active with GPIO configured as EN1&EN2 control and IC_EN control. Initial value is determined by CONF pin setting at the start-up in CONF_EN = 1
			<b>Value      Description</b>
[3:0]	RW	CH2_EN_DLY	

## High-Performance, Dual-Channel DC-DC Converter for Automotive Applications

Bit	Type	Symbol	Description
			0x0 0
			0x1 0.5 ms
			0x2 1.0 ms
			0x3 1.5 ms
			0x4 2.0 ms
			0x5 2.5 ms
			0x6 3.0 ms
			0x7 3.5 ms
			0x8 4.0 ms
			0x9 4.5 ms
			0xA 5.0 ms
			0xB 5.5 ms
			0xC 6.0 ms
			0xD 6.5 ms
			0xE 7.0 ms
			0xF 7.5 ms

**Table 32: SYS\_CONFIG\_2 (0x000D)**

Bit	Type	Symbol	Description										
[6:5]	RW	OC_LATCHOFF	<p>Over-current latch-off setting. BUCK shut-down after OCP for 8 <math>\mu</math>s/1 ms/3 ms unless disable setting. IRQ is generated unless IRQ is masked.</p> <table border="1"> <thead> <tr> <th>Value</th> <th>Description</th> </tr> </thead> <tbody> <tr> <td>0x0</td> <td>Latch off disable</td> </tr> <tr> <td>0x1</td> <td>Latch off after 8 <math>\mu</math>s of OCP signal</td> </tr> <tr> <td>0x2</td> <td>Latch off after 1 ms of OCP signal</td> </tr> <tr> <td>0x3</td> <td>Latch off after 3 ms of OCP signal</td> </tr> </tbody> </table>	Value	Description	0x0	Latch off disable	0x1	Latch off after 8 $\mu$ s of OCP signal	0x2	Latch off after 1 ms of OCP signal	0x3	Latch off after 3 ms of OCP signal
Value	Description												
0x0	Latch off disable												
0x1	Latch off after 8 $\mu$ s of OCP signal												
0x2	Latch off after 1 ms of OCP signal												
0x3	Latch off after 3 ms of OCP signal												
[4]	RW	OC_DVC_MASK	Over-current event (IRQ and latch-off feature) mask during DVC ramp-up and ramp-down for both CH1 and CH2										
[3:2]	RW	PG_DVC_MASK	<p>Power-good mask during DVC for both CH1 and CH2</p> <table border="1"> <thead> <tr> <th>Value</th> <th>Description</th> </tr> </thead> <tbody> <tr> <td>0x0</td> <td>No mask</td> </tr> <tr> <td>0x1</td> <td>Mask as not power-good during DVC</td> </tr> <tr> <td>0x2</td> <td>Mask as power-good during DVC</td> </tr> <tr> <td>0x3</td> <td>Reserved</td> </tr> </tbody> </table>	Value	Description	0x0	No mask	0x1	Mask as not power-good during DVC	0x2	Mask as power-good during DVC	0x3	Reserved
Value	Description												
0x0	No mask												
0x1	Mask as not power-good during DVC												
0x2	Mask as power-good during DVC												
0x3	Reserved												

## High-Performance, Dual-Channel DC-DC Converter for Automotive Applications

**Table 33: SYS\_CONFIG\_3 (0x000E)**

Bit	Type	Symbol	Description																		
[6:4]	RW	OSC_TUNE	Tune oscillator frequency, tuned frequency = Current + OSC_TUNE * 160 kHz <table border="1"> <thead> <tr> <th>Value</th> <th>Description</th> </tr> </thead> <tbody> <tr><td>0x3</td><td>3</td></tr> <tr><td>0x2</td><td>2</td></tr> <tr><td>0x1</td><td>1</td></tr> <tr><td>0x0</td><td>0</td></tr> <tr><td>0x7</td><td>-1</td></tr> <tr><td>0x6</td><td>-2</td></tr> <tr><td>0x5</td><td>-3</td></tr> <tr><td>0x4</td><td>-4</td></tr> </tbody> </table>	Value	Description	0x3	3	0x2	2	0x1	1	0x0	0	0x7	-1	0x6	-2	0x5	-3	0x4	-4
Value	Description																				
0x3	3																				
0x2	2																				
0x1	1																				
0x0	0																				
0x7	-1																				
0x6	-2																				
0x5	-3																				
0x4	-4																				
[1]	RW	I2C_TIMEOUT	Enable automatic reset of 2-wire interface (if SDA stays low for >50 ms).																		

**Table 34: SYS\_GPIO0\_0 (0x0010)**

Bit	Type	Symbol	Description																																		
[4:1]	RW	GPIO0_MODE	GPIO function mode select <table border="1"> <thead> <tr> <th>Value</th> <th>Description</th> </tr> </thead> <tbody> <tr><td>0x0</td><td>GPIO disable</td></tr> <tr><td>0x1</td><td>EN1 input</td></tr> <tr><td>0x2</td><td>EN2 input</td></tr> <tr><td>0x3</td><td>EN1 &amp; EN2 input</td></tr> <tr><td>0x4</td><td>DVC1 input</td></tr> <tr><td>0x5</td><td>DVC2 input</td></tr> <tr><td>0x6</td><td>DVC1 &amp; DVC2 input</td></tr> <tr><td>0x7</td><td>RELOAD input</td></tr> <tr><td>0x8</td><td>PG1 output</td></tr> <tr><td>0x9</td><td>PG2 output</td></tr> <tr><td>0xA</td><td>PG1 &amp; PG2 output</td></tr> <tr><td>0xB</td><td>SG output</td></tr> <tr><td>0xC</td><td>nIRQ output</td></tr> <tr><td>0xD</td><td>Reserved</td></tr> <tr><td>0xE</td><td>Low output</td></tr> <tr><td>0xF</td><td>High output</td></tr> </tbody> </table>	Value	Description	0x0	GPIO disable	0x1	EN1 input	0x2	EN2 input	0x3	EN1 & EN2 input	0x4	DVC1 input	0x5	DVC2 input	0x6	DVC1 & DVC2 input	0x7	RELOAD input	0x8	PG1 output	0x9	PG2 output	0xA	PG1 & PG2 output	0xB	SG output	0xC	nIRQ output	0xD	Reserved	0xE	Low output	0xF	High output
Value	Description																																				
0x0	GPIO disable																																				
0x1	EN1 input																																				
0x2	EN2 input																																				
0x3	EN1 & EN2 input																																				
0x4	DVC1 input																																				
0x5	DVC2 input																																				
0x6	DVC1 & DVC2 input																																				
0x7	RELOAD input																																				
0x8	PG1 output																																				
0x9	PG2 output																																				
0xA	PG1 & PG2 output																																				
0xB	SG output																																				
0xC	nIRQ output																																				
0xD	Reserved																																				
0xE	Low output																																				
0xF	High output																																				
[0]	RW	GPIO0_OBUF	GPIO output buffer select <table border="1"> <thead> <tr> <th>Value</th> <th>Description</th> </tr> </thead> <tbody> <tr><td>0x0</td><td>open-drain output</td></tr> </tbody> </table>	Value	Description	0x0	open-drain output																														
Value	Description																																				
0x0	open-drain output																																				

## High-Performance, Dual-Channel DC-DC Converter for Automotive Applications

Bit	Type	Symbol	Description
			0x1 push-pull output

**Table 35: SYS\_GPIO0\_1 (0x0011)**

Bit	Type	Symbol	Description										
[7]	RW	GPIO0_DEB_FALL	GPI debounce falling edge										
[6]	RW	GPIO0_DEB_RISE	GPI debounce rising edge										
[5:4]	RW	GPIO0_DEB	<p>GPI debounce time</p> <table border="1"> <thead> <tr> <th>Value</th> <th>Description</th> </tr> </thead> <tbody> <tr> <td>0x0</td> <td>100 <math>\mu</math>s debounce</td> </tr> <tr> <td>0x1</td> <td>1 ms debounce</td> </tr> <tr> <td>0x2</td> <td>10 ms debounce</td> </tr> <tr> <td>0x3</td> <td>100 ms debounce</td> </tr> </tbody> </table>	Value	Description	0x0	100 $\mu$ s debounce	0x1	1 ms debounce	0x2	10 ms debounce	0x3	100 ms debounce
Value	Description												
0x0	100 $\mu$ s debounce												
0x1	1 ms debounce												
0x2	10 ms debounce												
0x3	100 ms debounce												
[3]	RW	GPIO0_PUPD	<p>GPIO pull-up/pull-down enable</p> <table border="1"> <thead> <tr> <th>Value</th> <th>Description</th> </tr> </thead> <tbody> <tr> <td>0x0</td> <td>GPI: pull-down disabled, GPO: pull-up to AVDD disabled</td> </tr> <tr> <td>0x1</td> <td>GPI: pull-down enabled, GPO: pull-up to AVDD enabled</td> </tr> </tbody> </table>	Value	Description	0x0	GPI: pull-down disabled, GPO: pull-up to AVDD disabled	0x1	GPI: pull-down enabled, GPO: pull-up to AVDD enabled				
Value	Description												
0x0	GPI: pull-down disabled, GPO: pull-up to AVDD disabled												
0x1	GPI: pull-down enabled, GPO: pull-up to AVDD enabled												
[2]	RW	GPIO0_POL	<p>GPIO polarity</p> <table border="1"> <thead> <tr> <th>Value</th> <th>Description</th> </tr> </thead> <tbody> <tr> <td>0x0</td> <td>GPIO is active-high</td> </tr> <tr> <td>0x1</td> <td>GPIO is active-low</td> </tr> </tbody> </table>	Value	Description	0x0	GPIO is active-high	0x1	GPIO is active-low				
Value	Description												
0x0	GPIO is active-high												
0x1	GPIO is active-low												
[1:0]	RW	GPIO0_TRIG	<p>GPI trigger type</p> <table border="1"> <thead> <tr> <th>Value</th> <th>Description</th> </tr> </thead> <tbody> <tr> <td>0x0</td> <td>Dual-edge triggered</td> </tr> <tr> <td>0x1</td> <td>Pos-edge triggered</td> </tr> <tr> <td>0x2</td> <td>Neg-edge triggered</td> </tr> <tr> <td>0x3</td> <td>Reserved (No trigger)</td> </tr> </tbody> </table>	Value	Description	0x0	Dual-edge triggered	0x1	Pos-edge triggered	0x2	Neg-edge triggered	0x3	Reserved (No trigger)
Value	Description												
0x0	Dual-edge triggered												
0x1	Pos-edge triggered												
0x2	Neg-edge triggered												
0x3	Reserved (No trigger)												

**Table 36: SYS\_GPIO1\_0 (0x0012)**

Bit	Type	Symbol	Description												
[4:1]	RW	GPIO1_MODE	<p>GPIO function mode select. Initial value is determined by CONF pin setting at the start-up in CONF_EN = 1</p> <table border="1"> <thead> <tr> <th>Value</th> <th>Description</th> </tr> </thead> <tbody> <tr> <td>0x0</td> <td>GPIO disable</td> </tr> <tr> <td>0x1</td> <td>EN1 input</td> </tr> <tr> <td>0x2</td> <td>EN2 input</td> </tr> <tr> <td>0x3</td> <td>EN1 &amp; EN2 input</td> </tr> <tr> <td>0x4</td> <td>DVC1 input</td> </tr> </tbody> </table>	Value	Description	0x0	GPIO disable	0x1	EN1 input	0x2	EN2 input	0x3	EN1 & EN2 input	0x4	DVC1 input
Value	Description														
0x0	GPIO disable														
0x1	EN1 input														
0x2	EN2 input														
0x3	EN1 & EN2 input														
0x4	DVC1 input														

## High-Performance, Dual-Channel DC-DC Converter for Automotive Applications

Bit	Type	Symbol	Description
			0x5 DVC2 input 0x6 DVC1 & DVC2 input 0x7 RELOAD input 0x8 PG1 output 0x9 PG2 output 0xA PG1 & PG2 output 0xB SG output 0xC nLRQ output 0xD Reserved 0xE Low output 0xF High output
[0]	RW	GPIO1_OBUF	GPIO output buffer select. Initial value is determined by CONF pin setting at the start-up in CONF_EN = 1 <b>Value</b> <b>Description</b> 0x0            open-drain output 0x1            push-pull output

**Table 37: SYS\_GPIO1\_1 (0x0013)**

Bit	Type	Symbol	Description
[7]	RW	GPIO1_DEB_FALL	GPI debounce falling edge. Initial value is determined by CONF pin setting at the start-up in CONF_EN = 1
[6]	RW	GPIO1_DEB_RISE	GPI debounce rising edge. Initial value is determined by CONF pin setting at the start-up in CONF_EN = 1
[5:4]	RW	GPIO1_DEB	GPI debounce time. Initial value is determined by CONF pin setting at the start-up in CONF_EN = 1 <b>Value</b> <b>Description</b> 0x0            100 $\mu$ s debounce 0x1            1 ms debounce 0x2            10 ms debounce 0x3            100 ms debounce
[3]	RW	GPIO1_PUPD	GPIO pull-up/pull-down enable. Initial value is determined by CONF pin setting at the start-up in CONF_EN = 1 <b>Value</b> <b>Description</b> 0x0            GPI: pull-down disabled, GPO: pull-up to AVDD disabled 0x1            GPI: pull-down enabled, GPO: pull-up to AVDD enabled
[2]	RW	GPIO1_POL	GPIO polarity. Initial value is determined by CONF pin setting at the start-up in CONF_EN = 1 <b>Value</b> <b>Description</b> 0x0            GPIO is active-high



## High-Performance, Dual-Channel DC-DC Converter for Automotive Applications

Bit	Type	Symbol	Description										
			0x1 GPIO is active-low										
[1:0]	RW	GPIO1_TRIG	<p>GPI trigger type. Initial value is determined by CONF pin setting at the start-up in CONF_EN = 1</p> <table border="1"> <thead> <tr> <th>Value</th> <th>Description</th> </tr> </thead> <tbody> <tr> <td>0x0</td> <td>Dual-edge triggered</td> </tr> <tr> <td>0x1</td> <td>Pos-edge triggered</td> </tr> <tr> <td>0x2</td> <td>Neg-edge triggered</td> </tr> <tr> <td>0x3</td> <td>Reserved (No trigger)</td> </tr> </tbody> </table>	Value	Description	0x0	Dual-edge triggered	0x1	Pos-edge triggered	0x2	Neg-edge triggered	0x3	Reserved (No trigger)
Value	Description												
0x0	Dual-edge triggered												
0x1	Pos-edge triggered												
0x2	Neg-edge triggered												
0x3	Reserved (No trigger)												

**Table 38: SYS\_GPIO2\_0 (0x0014)**

Bit	Type	Symbol	Description																																		
[4:1]	RW	GPIO2_MODE	<p>GPIO function mode select. Initial value is determined by CONF pin setting at the start-up in CONF_EN = 1</p> <table border="1"> <thead> <tr> <th>Value</th> <th>Description</th> </tr> </thead> <tbody> <tr> <td>0x0</td> <td>GPIO disable</td> </tr> <tr> <td>0x1</td> <td>EN1 input</td> </tr> <tr> <td>0x2</td> <td>EN2 input</td> </tr> <tr> <td>0x3</td> <td>EN1 &amp; EN2 input</td> </tr> <tr> <td>0x4</td> <td>DVC1 input</td> </tr> <tr> <td>0x5</td> <td>DVC2 input</td> </tr> <tr> <td>0x6</td> <td>DVC1 &amp; DVC2 input</td> </tr> <tr> <td>0x7</td> <td>RELOAD input</td> </tr> <tr> <td>0x8</td> <td>PG1 output</td> </tr> <tr> <td>0x9</td> <td>PG2 output</td> </tr> <tr> <td>0xA</td> <td>PG1 &amp; PG2 output</td> </tr> <tr> <td>0xB</td> <td>SG output</td> </tr> <tr> <td>0xC</td> <td>nIRQ output</td> </tr> <tr> <td>0xD</td> <td>Reserved</td> </tr> <tr> <td>0xE</td> <td>Low output</td> </tr> <tr> <td>0xF</td> <td>High output</td> </tr> </tbody> </table>	Value	Description	0x0	GPIO disable	0x1	EN1 input	0x2	EN2 input	0x3	EN1 & EN2 input	0x4	DVC1 input	0x5	DVC2 input	0x6	DVC1 & DVC2 input	0x7	RELOAD input	0x8	PG1 output	0x9	PG2 output	0xA	PG1 & PG2 output	0xB	SG output	0xC	nIRQ output	0xD	Reserved	0xE	Low output	0xF	High output
Value	Description																																				
0x0	GPIO disable																																				
0x1	EN1 input																																				
0x2	EN2 input																																				
0x3	EN1 & EN2 input																																				
0x4	DVC1 input																																				
0x5	DVC2 input																																				
0x6	DVC1 & DVC2 input																																				
0x7	RELOAD input																																				
0x8	PG1 output																																				
0x9	PG2 output																																				
0xA	PG1 & PG2 output																																				
0xB	SG output																																				
0xC	nIRQ output																																				
0xD	Reserved																																				
0xE	Low output																																				
0xF	High output																																				
[0]	RW	GPIO2_OBUF	<p>GPIO output buffer select. Initial value is determined by CONF pin setting at the start-up in CONF_EN = 1</p> <table border="1"> <thead> <tr> <th>Value</th> <th>Description</th> </tr> </thead> <tbody> <tr> <td>0x0</td> <td>open-drain output</td> </tr> <tr> <td>0x1</td> <td>push-pull output</td> </tr> </tbody> </table>	Value	Description	0x0	open-drain output	0x1	push-pull output																												
Value	Description																																				
0x0	open-drain output																																				
0x1	push-pull output																																				

## High-Performance, Dual-Channel DC-DC Converter for Automotive Applications

**Table 39: SYS\_GPIO2\_1 (0x0015)**

Bit	Type	Symbol	Description										
[7]	RW	GPIO2_DEB_FALL	GPI debounce falling edge. Initial value is determined by CONF pin setting at the start-up in CONF_EN = 1										
[6]	RW	GPIO2_DEB_RISE	GPI debounce rising edge. Initial value is determined by CONF pin setting at the start-up in CONF_EN = 1										
[5:4]	RW	GPIO2_DEB	<p>GPI debounce time. Initial value is determined by CONF pin setting at the start-up in CONF_EN = 1</p> <table border="1"> <thead> <tr> <th>Value</th> <th>Description</th> </tr> </thead> <tbody> <tr> <td>0x0</td> <td>100 <math>\mu</math>s debounce</td> </tr> <tr> <td>0x1</td> <td>1 ms debounce</td> </tr> <tr> <td>0x2</td> <td>10 ms debounce</td> </tr> <tr> <td>0x3</td> <td>100 ms debounce</td> </tr> </tbody> </table>	Value	Description	0x0	100 $\mu$ s debounce	0x1	1 ms debounce	0x2	10 ms debounce	0x3	100 ms debounce
Value	Description												
0x0	100 $\mu$ s debounce												
0x1	1 ms debounce												
0x2	10 ms debounce												
0x3	100 ms debounce												
[3]	RW	GPIO2_PUPD	<p>GPIO pull-up/pull-down enable. Initial value is determined by CONF pin setting at the start-up in CONF_EN = 1</p> <table border="1"> <thead> <tr> <th>Value</th> <th>Description</th> </tr> </thead> <tbody> <tr> <td>0x0</td> <td>GPI: pull-down disabled, GPO: pull-up to AVDD disabled</td> </tr> <tr> <td>0x1</td> <td>GPI: pull-down enabled, GPO: pull-up to AVDD enabled</td> </tr> </tbody> </table>	Value	Description	0x0	GPI: pull-down disabled, GPO: pull-up to AVDD disabled	0x1	GPI: pull-down enabled, GPO: pull-up to AVDD enabled				
Value	Description												
0x0	GPI: pull-down disabled, GPO: pull-up to AVDD disabled												
0x1	GPI: pull-down enabled, GPO: pull-up to AVDD enabled												
[2]	RW	GPIO2_POL	<p>GPIO polarity. Initial value is determined by CONF pin setting at the start-up in CONF_EN = 1</p> <table border="1"> <thead> <tr> <th>Value</th> <th>Description</th> </tr> </thead> <tbody> <tr> <td>0x0</td> <td>GPIO is active-high</td> </tr> <tr> <td>0x1</td> <td>GPIO is active-low</td> </tr> </tbody> </table>	Value	Description	0x0	GPIO is active-high	0x1	GPIO is active-low				
Value	Description												
0x0	GPIO is active-high												
0x1	GPIO is active-low												
[1:0]	RW	GPIO2_TRIG	<p>GPI trigger type. Initial value is determined by CONF pin setting at the start-up in CONF_EN = 1</p> <table border="1"> <thead> <tr> <th>Value</th> <th>Description</th> </tr> </thead> <tbody> <tr> <td>0x0</td> <td>Dual-edge triggered</td> </tr> <tr> <td>0x1</td> <td>Pos-edge triggered</td> </tr> <tr> <td>0x2</td> <td>Neg-edge triggered</td> </tr> <tr> <td>0x3</td> <td>Reserved (No trigger)</td> </tr> </tbody> </table>	Value	Description	0x0	Dual-edge triggered	0x1	Pos-edge triggered	0x2	Neg-edge triggered	0x3	Reserved (No trigger)
Value	Description												
0x0	Dual-edge triggered												
0x1	Pos-edge triggered												
0x2	Neg-edge triggered												
0x3	Reserved (No trigger)												

## High-Performance, Dual-Channel DC-DC Converter for Automotive Applications

### 5.1.2 Buck1

**Table 40: BUCK\_BUCK1\_0 (0x0020)**

Bit	Type	Symbol	Description																		
[6:4]	RW	CH1_SR_DVC_DWN	Voltage slew-rate for DVC ramp-down <table border="1"> <thead> <tr> <th>Value</th> <th>Description</th> </tr> </thead> <tbody> <tr> <td>0x0</td> <td>10 mV/8 <math>\mu</math>s</td> </tr> <tr> <td>0x1</td> <td>10 mV/4 <math>\mu</math>s</td> </tr> <tr> <td>0x2</td> <td>10 mV/2 <math>\mu</math>s</td> </tr> <tr> <td>0x3</td> <td>10 mV/<math>\mu</math>s</td> </tr> <tr> <td>0x4</td> <td>20 mV/<math>\mu</math>s</td> </tr> <tr> <td>0x5</td> <td>Reserved</td> </tr> <tr> <td>0x6</td> <td>Reserved</td> </tr> <tr> <td>0x7</td> <td>Reserved</td> </tr> </tbody> </table>	Value	Description	0x0	10 mV/8 $\mu$ s	0x1	10 mV/4 $\mu$ s	0x2	10 mV/2 $\mu$ s	0x3	10 mV/ $\mu$ s	0x4	20 mV/ $\mu$ s	0x5	Reserved	0x6	Reserved	0x7	Reserved
Value	Description																				
0x0	10 mV/8 $\mu$ s																				
0x1	10 mV/4 $\mu$ s																				
0x2	10 mV/2 $\mu$ s																				
0x3	10 mV/ $\mu$ s																				
0x4	20 mV/ $\mu$ s																				
0x5	Reserved																				
0x6	Reserved																				
0x7	Reserved																				
[3:1]	RW	CH1_SR_DVC_UP	Voltage slew-rate for DVC ramp-up <table border="1"> <thead> <tr> <th>Value</th> <th>Description</th> </tr> </thead> <tbody> <tr> <td>0x0</td> <td>10 mV/8 <math>\mu</math>s</td> </tr> <tr> <td>0x1</td> <td>10 mV/4 <math>\mu</math>s</td> </tr> <tr> <td>0x2</td> <td>10 mV/2 <math>\mu</math>s</td> </tr> <tr> <td>0x3</td> <td>10 mV/<math>\mu</math>s</td> </tr> <tr> <td>0x4</td> <td>20 mV/<math>\mu</math>s</td> </tr> <tr> <td>0x5</td> <td>40 mV/<math>\mu</math>s</td> </tr> <tr> <td>0x6</td> <td>Reserved</td> </tr> <tr> <td>0x7</td> <td>Reserved</td> </tr> </tbody> </table>	Value	Description	0x0	10 mV/8 $\mu$ s	0x1	10 mV/4 $\mu$ s	0x2	10 mV/2 $\mu$ s	0x3	10 mV/ $\mu$ s	0x4	20 mV/ $\mu$ s	0x5	40 mV/ $\mu$ s	0x6	Reserved	0x7	Reserved
Value	Description																				
0x0	10 mV/8 $\mu$ s																				
0x1	10 mV/4 $\mu$ s																				
0x2	10 mV/2 $\mu$ s																				
0x3	10 mV/ $\mu$ s																				
0x4	20 mV/ $\mu$ s																				
0x5	40 mV/ $\mu$ s																				
0x6	Reserved																				
0x7	Reserved																				
[0]	RW	CH1_EN	Channel enable. Initial value is determined by CONF pin setting at the start-up in CONF_EN = 1																		

**Table 41: BUCK\_BUCK1\_1 (0x0021)**

Bit	Type	Symbol	Description																		
[6:4]	RW	CH1_SR_SHDN	Voltage slew-rate during shut-down <table border="1"> <thead> <tr> <th>Value</th> <th>Description</th> </tr> </thead> <tbody> <tr> <td>0x0</td> <td>10 mV/8 <math>\mu</math>s</td> </tr> <tr> <td>0x1</td> <td>10 mV/4 <math>\mu</math>s</td> </tr> <tr> <td>0x2</td> <td>10 mV/2 <math>\mu</math>s</td> </tr> <tr> <td>0x3</td> <td>10 mV/<math>\mu</math>s</td> </tr> <tr> <td>0x4</td> <td>20 mV/<math>\mu</math>s</td> </tr> <tr> <td>0x5</td> <td>Reserved</td> </tr> <tr> <td>0x6</td> <td>Reserved</td> </tr> <tr> <td>0x7</td> <td>Immediate power-down</td> </tr> </tbody> </table>	Value	Description	0x0	10 mV/8 $\mu$ s	0x1	10 mV/4 $\mu$ s	0x2	10 mV/2 $\mu$ s	0x3	10 mV/ $\mu$ s	0x4	20 mV/ $\mu$ s	0x5	Reserved	0x6	Reserved	0x7	Immediate power-down
Value	Description																				
0x0	10 mV/8 $\mu$ s																				
0x1	10 mV/4 $\mu$ s																				
0x2	10 mV/2 $\mu$ s																				
0x3	10 mV/ $\mu$ s																				
0x4	20 mV/ $\mu$ s																				
0x5	Reserved																				
0x6	Reserved																				
0x7	Immediate power-down																				

## High-Performance, Dual-Channel DC-DC Converter for Automotive Applications

Bit	Type	Symbol	Description																		
[3:1]	RW	CH1_SR_STARTUP	<p>Voltage slew-rate during startup</p> <table border="1"> <thead> <tr> <th>Value</th> <th>Description</th> </tr> </thead> <tbody> <tr> <td>0x0</td> <td>10 mV/8 <math>\mu</math>s</td> </tr> <tr> <td>0x1</td> <td>10 mV/4 <math>\mu</math>s</td> </tr> <tr> <td>0x2</td> <td>10 mV/2 <math>\mu</math>s</td> </tr> <tr> <td>0x3</td> <td>10 mV/<math>\mu</math>s</td> </tr> <tr> <td>0x4</td> <td>20 mV/<math>\mu</math>s</td> </tr> <tr> <td>0x5</td> <td>40 mV/<math>\mu</math>s</td> </tr> <tr> <td>0x6</td> <td>Reserved</td> </tr> <tr> <td>0x7</td> <td>Reserved</td> </tr> </tbody> </table>	Value	Description	0x0	10 mV/8 $\mu$ s	0x1	10 mV/4 $\mu$ s	0x2	10 mV/2 $\mu$ s	0x3	10 mV/ $\mu$ s	0x4	20 mV/ $\mu$ s	0x5	40 mV/ $\mu$ s	0x6	Reserved	0x7	Reserved
Value	Description																				
0x0	10 mV/8 $\mu$ s																				
0x1	10 mV/4 $\mu$ s																				
0x2	10 mV/2 $\mu$ s																				
0x3	10 mV/ $\mu$ s																				
0x4	20 mV/ $\mu$ s																				
0x5	40 mV/ $\mu$ s																				
0x6	Reserved																				
0x7	Reserved																				
[0]	RW	CH1_PD_DIS	Pull-down while buck is disabled. 0: enable, 1: disable																		

**Table 42: BUCK\_BUCK1\_2 (0x0022)**

Bit	Type	Symbol	Description																																		
[3:0]	RW	CH1_ILIM	<p>Select OCP threshold (A). The value is configured by OTP and should not be modified while the buck is active.</p> <table border="1"> <thead> <tr> <th>Value</th> <th>Description</th> </tr> </thead> <tbody> <tr> <td>0x0</td> <td>Reserved</td> </tr> <tr> <td>0x1</td> <td>3.5</td> </tr> <tr> <td>0x2</td> <td>4.0</td> </tr> <tr> <td>0x3</td> <td>4.5</td> </tr> <tr> <td>0x4</td> <td>5.0</td> </tr> <tr> <td>0x5</td> <td>5.5</td> </tr> <tr> <td>0x6</td> <td>6.0</td> </tr> <tr> <td>0x7</td> <td>6.5</td> </tr> <tr> <td>0x8</td> <td>7.0</td> </tr> <tr> <td>0x9</td> <td>7.5</td> </tr> <tr> <td>0xA</td> <td>8.0</td> </tr> <tr> <td>0xB</td> <td>8.5</td> </tr> <tr> <td>0xC</td> <td>9.0</td> </tr> <tr> <td>0xD</td> <td>9.5</td> </tr> <tr> <td>0xE</td> <td>10.0</td> </tr> <tr> <td>0xF</td> <td>Disable</td> </tr> </tbody> </table>	Value	Description	0x0	Reserved	0x1	3.5	0x2	4.0	0x3	4.5	0x4	5.0	0x5	5.5	0x6	6.0	0x7	6.5	0x8	7.0	0x9	7.5	0xA	8.0	0xB	8.5	0xC	9.0	0xD	9.5	0xE	10.0	0xF	Disable
Value	Description																																				
0x0	Reserved																																				
0x1	3.5																																				
0x2	4.0																																				
0x3	4.5																																				
0x4	5.0																																				
0x5	5.5																																				
0x6	6.0																																				
0x7	6.5																																				
0x8	7.0																																				
0x9	7.5																																				
0xA	8.0																																				
0xB	8.5																																				
0xC	9.0																																				
0xD	9.5																																				
0xE	10.0																																				
0xF	Disable																																				

## High-Performance, Dual-Channel DC-DC Converter for Automotive Applications

**Table 43: BUCK\_BUCK1\_3 (0x0023)**

Bit	Type	Symbol	Description																		
[7:0]	RW	CH1_VMAX	<p>VOUT max setting (V): From 0.30 V (0x1E) to 1.90 V (0xBE) in 10 mV steps. This is a read-only register.</p> <table border="1"> <thead> <tr> <th>Value</th> <th>Description</th> </tr> </thead> <tbody> <tr> <td>0x1E</td> <td>0.3</td> </tr> <tr> <td>0x1F</td> <td>0.31</td> </tr> <tr> <td>0x20</td> <td>0.32</td> </tr> <tr> <td colspan="2">Continuing through...</td> </tr> <tr> <td>0x99</td> <td>1.53</td> </tr> <tr> <td colspan="2">To...</td> </tr> <tr> <td>0xBD</td> <td>1.89</td> </tr> <tr> <td>0xBE</td> <td>1.9</td> </tr> </tbody> </table>	Value	Description	0x1E	0.3	0x1F	0.31	0x20	0.32	Continuing through...		0x99	1.53	To...		0xBD	1.89	0xBE	1.9
Value	Description																				
0x1E	0.3																				
0x1F	0.31																				
0x20	0.32																				
Continuing through...																					
0x99	1.53																				
To...																					
0xBD	1.89																				
0xBE	1.9																				

**Table 44: BUCK\_BUCK1\_4 (0x0024)**

Bit	Type	Symbol	Description										
[4]	RW	CH1_VSEL	Output voltage and operation selection: 0: A, 1: B. Initial value is determined by CONF pin setting at the start-up in CONF_EN = 1										
[3:2]	RW	CH1_B_MODE	<p>Operation mode selection. Initial value is determined by CONF pin setting at the start-up in CONF_EN = 1</p> <table border="1"> <thead> <tr> <th>Value</th> <th>Description</th> </tr> </thead> <tbody> <tr> <td>0x0</td> <td>Force PFM operation</td> </tr> <tr> <td>0x1</td> <td>Force PWM operation</td> </tr> <tr> <td>0x2</td> <td>Force PWM operation</td> </tr> <tr> <td>0x3</td> <td>Auto mode</td> </tr> </tbody> </table>	Value	Description	0x0	Force PFM operation	0x1	Force PWM operation	0x2	Force PWM operation	0x3	Auto mode
Value	Description												
0x0	Force PFM operation												
0x1	Force PWM operation												
0x2	Force PWM operation												
0x3	Auto mode												
[1:0]	RW	CH1_A_MODE	<p>Operation mode selection. Initial value is determined by CONF pin setting at the start-up in CONF_EN = 1</p> <table border="1"> <thead> <tr> <th>Value</th> <th>Description</th> </tr> </thead> <tbody> <tr> <td>0x0</td> <td>Force PFM operation</td> </tr> <tr> <td>0x1</td> <td>Force PWM operation</td> </tr> <tr> <td>0x2</td> <td>Force PWM operation</td> </tr> <tr> <td>0x3</td> <td>Auto mode</td> </tr> </tbody> </table>	Value	Description	0x0	Force PFM operation	0x1	Force PWM operation	0x2	Force PWM operation	0x3	Auto mode
Value	Description												
0x0	Force PFM operation												
0x1	Force PWM operation												
0x2	Force PWM operation												
0x3	Auto mode												

## High-Performance, Dual-Channel DC-DC Converter for Automotive Applications

**Table 45: BUCK\_BUCK1\_5 (0x0025)**

Bit	Type	Symbol	Description																				
[7:0]	RW	CH1_A_VOUT	<p>Output voltage setting A: Initial value is determined by CONF pin setting at the start-up in CONF_EN = 1 From 0.30 V (0x1E) to 1.90 V (0xBE) in steps of 10 mV (default 1.0 V) Write-protected when value is written below 0.30 V or above 1.90 V</p> <table border="1"> <thead> <tr> <th>Value</th> <th>Description</th> </tr> </thead> <tbody> <tr> <td>0x1E</td> <td>0.3</td> </tr> <tr> <td>0x1F</td> <td>0.31</td> </tr> <tr> <td>0x20</td> <td>0.32</td> </tr> <tr> <td colspan="2">Continuing through...</td> </tr> <tr> <td>0x64</td> <td>1</td> </tr> <tr> <td colspan="2">To...</td> </tr> <tr> <td>0xBC</td> <td>1.88</td> </tr> <tr> <td>0xBD</td> <td>1.89</td> </tr> <tr> <td>0xBE</td> <td>1.9</td> </tr> </tbody> </table>	Value	Description	0x1E	0.3	0x1F	0.31	0x20	0.32	Continuing through...		0x64	1	To...		0xBC	1.88	0xBD	1.89	0xBE	1.9
Value	Description																						
0x1E	0.3																						
0x1F	0.31																						
0x20	0.32																						
Continuing through...																							
0x64	1																						
To...																							
0xBC	1.88																						
0xBD	1.89																						
0xBE	1.9																						

**Table 46: BUCK\_BUCK1\_6 (0x0026)**

Bit	Type	Symbol	Description																				
[7:0]	RW	CH1_B_VOUT	<p>Output voltage setting B: Initial value is determined by CONF pin setting at the start-up in CONF_EN = 1 From 0.30 V (0x1E) to 1.90 V (0xBE) in steps of 10 mV (default 1.0 V) Write-protected when value is written below 0.30 V or above 1.90 V</p> <table border="1"> <thead> <tr> <th>Value</th> <th>Description</th> </tr> </thead> <tbody> <tr> <td>0x1E</td> <td>0.3</td> </tr> <tr> <td>0x1F</td> <td>0.31</td> </tr> <tr> <td>0x20</td> <td>0.32</td> </tr> <tr> <td colspan="2">Continuing through...</td> </tr> <tr> <td>0x64</td> <td>1</td> </tr> <tr> <td colspan="2">To...</td> </tr> <tr> <td>0xBC</td> <td>1.88</td> </tr> <tr> <td>0xBD</td> <td>1.89</td> </tr> <tr> <td>0xBE</td> <td>1.9</td> </tr> </tbody> </table>	Value	Description	0x1E	0.3	0x1F	0.31	0x20	0.32	Continuing through...		0x64	1	To...		0xBC	1.88	0xBD	1.89	0xBE	1.9
Value	Description																						
0x1E	0.3																						
0x1F	0.31																						
0x20	0.32																						
Continuing through...																							
0x64	1																						
To...																							
0xBC	1.88																						
0xBD	1.89																						
0xBE	1.9																						

## High-Performance, Dual-Channel DC-DC Converter for Automotive Applications

### 5.1.3 Buck2

**Table 47: BUCK\_BUCK2\_0 (0x0028)**

Bit	Type	Symbol	Description																		
[6:4]	RW	CH2_SR_DVC_DWN	Voltage slew-rate for DVC ramp-down <table border="1"> <thead> <tr> <th>Value</th> <th>Description</th> </tr> </thead> <tbody> <tr><td>0x0</td><td>10 mV/8 <math>\mu</math>s</td></tr> <tr><td>0x1</td><td>10 mV/4 <math>\mu</math>s</td></tr> <tr><td>0x2</td><td>10 mV/2 <math>\mu</math>s</td></tr> <tr><td>0x3</td><td>10 mV/<math>\mu</math>s</td></tr> <tr><td>0x4</td><td>20 mV/<math>\mu</math>s</td></tr> <tr><td>0x5</td><td>Reserved</td></tr> <tr><td>0x6</td><td>Reserved</td></tr> <tr><td>0x7</td><td>Reserved</td></tr> </tbody> </table>	Value	Description	0x0	10 mV/8 $\mu$ s	0x1	10 mV/4 $\mu$ s	0x2	10 mV/2 $\mu$ s	0x3	10 mV/ $\mu$ s	0x4	20 mV/ $\mu$ s	0x5	Reserved	0x6	Reserved	0x7	Reserved
Value	Description																				
0x0	10 mV/8 $\mu$ s																				
0x1	10 mV/4 $\mu$ s																				
0x2	10 mV/2 $\mu$ s																				
0x3	10 mV/ $\mu$ s																				
0x4	20 mV/ $\mu$ s																				
0x5	Reserved																				
0x6	Reserved																				
0x7	Reserved																				
[3:1]	RW	CH2_SR_DVC_UP	Voltage slew-rate for DVC ramp-up <table border="1"> <thead> <tr> <th>Value</th> <th>Description</th> </tr> </thead> <tbody> <tr><td>0x0</td><td>10 mV/8 <math>\mu</math>s</td></tr> <tr><td>0x1</td><td>10 mV/4 <math>\mu</math>s</td></tr> <tr><td>0x2</td><td>10 mV/2 <math>\mu</math>s</td></tr> <tr><td>0x3</td><td>10 mV/<math>\mu</math>s</td></tr> <tr><td>0x4</td><td>20 mV/<math>\mu</math>s</td></tr> <tr><td>0x5</td><td>40 mV/<math>\mu</math>s</td></tr> <tr><td>0x6</td><td>Reserved</td></tr> <tr><td>0x7</td><td>Reserved</td></tr> </tbody> </table>	Value	Description	0x0	10 mV/8 $\mu$ s	0x1	10 mV/4 $\mu$ s	0x2	10 mV/2 $\mu$ s	0x3	10 mV/ $\mu$ s	0x4	20 mV/ $\mu$ s	0x5	40 mV/ $\mu$ s	0x6	Reserved	0x7	Reserved
Value	Description																				
0x0	10 mV/8 $\mu$ s																				
0x1	10 mV/4 $\mu$ s																				
0x2	10 mV/2 $\mu$ s																				
0x3	10 mV/ $\mu$ s																				
0x4	20 mV/ $\mu$ s																				
0x5	40 mV/ $\mu$ s																				
0x6	Reserved																				
0x7	Reserved																				
[0]	RW	CH2_EN	Channel enable. Initial value is determined by CONF pin setting at the start-up in CONF_EN = 1																		

**Table 48: BUCK\_BUCK2\_1 (0x0029)**

Bit	Type	Symbol	Description																		
[6:4]	RW	CH2_SR_SHDN	Voltage slew-rate during power-down <table border="1"> <thead> <tr> <th>Value</th> <th>Description</th> </tr> </thead> <tbody> <tr><td>0x0</td><td>10 mV/8 <math>\mu</math>s</td></tr> <tr><td>0x1</td><td>10 mV/4 <math>\mu</math>s</td></tr> <tr><td>0x2</td><td>10 mV/2 <math>\mu</math>s</td></tr> <tr><td>0x3</td><td>10 mV/<math>\mu</math>s</td></tr> <tr><td>0x4</td><td>20 mV/<math>\mu</math>s</td></tr> <tr><td>0x5</td><td>Reserved</td></tr> <tr><td>0x6</td><td>Reserved</td></tr> <tr><td>0x7</td><td>Immediate power-down</td></tr> </tbody> </table>	Value	Description	0x0	10 mV/8 $\mu$ s	0x1	10 mV/4 $\mu$ s	0x2	10 mV/2 $\mu$ s	0x3	10 mV/ $\mu$ s	0x4	20 mV/ $\mu$ s	0x5	Reserved	0x6	Reserved	0x7	Immediate power-down
Value	Description																				
0x0	10 mV/8 $\mu$ s																				
0x1	10 mV/4 $\mu$ s																				
0x2	10 mV/2 $\mu$ s																				
0x3	10 mV/ $\mu$ s																				
0x4	20 mV/ $\mu$ s																				
0x5	Reserved																				
0x6	Reserved																				
0x7	Immediate power-down																				
[3:1]	RW	CH2_SR_STARTUP	Voltage slew-rate during startup																		

## High-Performance, Dual-Channel DC-DC Converter for Automotive Applications

Bit	Type	Symbol	Description																		
			<table border="1"> <thead> <tr> <th>Value</th> <th>Description</th> </tr> </thead> <tbody> <tr> <td>0x0</td> <td>10 mV/8 <math>\mu</math>s</td> </tr> <tr> <td>0x1</td> <td>10 mV/4 <math>\mu</math>s</td> </tr> <tr> <td>0x2</td> <td>10 mV/2 <math>\mu</math>s</td> </tr> <tr> <td>0x3</td> <td>10 mV/<math>\mu</math>s</td> </tr> <tr> <td>0x4</td> <td>20 mV/<math>\mu</math>s</td> </tr> <tr> <td>0x5</td> <td>40 mV/<math>\mu</math>s</td> </tr> <tr> <td>0x6</td> <td>Reserved</td> </tr> <tr> <td>0x7</td> <td>Reserved</td> </tr> </tbody> </table>	Value	Description	0x0	10 mV/8 $\mu$ s	0x1	10 mV/4 $\mu$ s	0x2	10 mV/2 $\mu$ s	0x3	10 mV/ $\mu$ s	0x4	20 mV/ $\mu$ s	0x5	40 mV/ $\mu$ s	0x6	Reserved	0x7	Reserved
Value	Description																				
0x0	10 mV/8 $\mu$ s																				
0x1	10 mV/4 $\mu$ s																				
0x2	10 mV/2 $\mu$ s																				
0x3	10 mV/ $\mu$ s																				
0x4	20 mV/ $\mu$ s																				
0x5	40 mV/ $\mu$ s																				
0x6	Reserved																				
0x7	Reserved																				
[0]	RW	CH2_PD_DIS	Pull-down while BUCK is disabled. 0: enable, 1: disable																		

**Table 49: BUCK\_BUCK2\_2 (0x002A)**

Bit	Type	Symbol	Description																																		
			Select OCP threshold <table border="1"> <thead> <tr> <th>Value</th> <th>Description</th> </tr> </thead> <tbody> <tr> <td>0x0</td> <td>Reserved</td> </tr> <tr> <td>0x1</td> <td>3.5</td> </tr> <tr> <td>0x2</td> <td>4.0</td> </tr> <tr> <td>0x3</td> <td>4.5</td> </tr> <tr> <td>0x4</td> <td>5.0</td> </tr> <tr> <td>0x5</td> <td>5.5</td> </tr> <tr> <td>0x6</td> <td>6.0</td> </tr> <tr> <td>0x7</td> <td>6.5</td> </tr> <tr> <td>0x8</td> <td>7.0</td> </tr> <tr> <td>0x9</td> <td>7.5</td> </tr> <tr> <td>0xA</td> <td>8.0</td> </tr> <tr> <td>0xB</td> <td>8.5</td> </tr> <tr> <td>0xC</td> <td>9.0</td> </tr> <tr> <td>0xD</td> <td>9.5</td> </tr> <tr> <td>0xE</td> <td>10.0</td> </tr> <tr> <td>0xF</td> <td>Disable</td> </tr> </tbody> </table>	Value	Description	0x0	Reserved	0x1	3.5	0x2	4.0	0x3	4.5	0x4	5.0	0x5	5.5	0x6	6.0	0x7	6.5	0x8	7.0	0x9	7.5	0xA	8.0	0xB	8.5	0xC	9.0	0xD	9.5	0xE	10.0	0xF	Disable
Value	Description																																				
0x0	Reserved																																				
0x1	3.5																																				
0x2	4.0																																				
0x3	4.5																																				
0x4	5.0																																				
0x5	5.5																																				
0x6	6.0																																				
0x7	6.5																																				
0x8	7.0																																				
0x9	7.5																																				
0xA	8.0																																				
0xB	8.5																																				
0xC	9.0																																				
0xD	9.5																																				
0xE	10.0																																				
0xF	Disable																																				
[3:0]	RW	CH2_ILIM																																			



## High-Performance, Dual-Channel DC-DC Converter for Automotive Applications

**Table 50: BUCK\_BUCK2\_3 (0x002B)**

Bit	Type	Symbol	Description																				
[7:0]	RW	CH2_VMAX	<p>VOUT max setting (V): From 0.30 V (0x1E) to 1.90 V (0xBE) in steps of 10 mV This is a read-only register.</p> <table border="1"> <thead> <tr> <th>Value</th> <th>Description</th> </tr> </thead> <tbody> <tr> <td>0x1E</td> <td>0.3</td> </tr> <tr> <td>0x1F</td> <td>0.31</td> </tr> <tr> <td>0x20</td> <td>0.32</td> </tr> <tr> <td colspan="2">Continuing through...</td> </tr> <tr> <td>0x64</td> <td>1</td> </tr> <tr> <td colspan="2">To...</td> </tr> <tr> <td>0xBC</td> <td>1.88</td> </tr> <tr> <td>0xBD</td> <td>1.89</td> </tr> <tr> <td>0xBE</td> <td>1.9</td> </tr> </tbody> </table>	Value	Description	0x1E	0.3	0x1F	0.31	0x20	0.32	Continuing through...		0x64	1	To...		0xBC	1.88	0xBD	1.89	0xBE	1.9
Value	Description																						
0x1E	0.3																						
0x1F	0.31																						
0x20	0.32																						
Continuing through...																							
0x64	1																						
To...																							
0xBC	1.88																						
0xBD	1.89																						
0xBE	1.9																						

**Table 51: BUCK\_BUCK2\_4 (0x002C)**

Bit	Type	Symbol	Description										
[4]	RW	CH2_VSEL	Output voltage and operation selection: 0: A, 1: B. Initial value is determined by CONF pin setting at the start-up in CONF_EN = 1										
[3:2]	RW	CH2_B_MODE	<p>Operation mode selection. Initial value is determined by CONF pin setting at the start-up in CONF_EN = 1</p> <table border="1"> <thead> <tr> <th>Value</th> <th>Description</th> </tr> </thead> <tbody> <tr> <td>0x0</td> <td>Force PFM operation</td> </tr> <tr> <td>0x1</td> <td>Force PWM operation</td> </tr> <tr> <td>0x2</td> <td>Force PWM operation</td> </tr> <tr> <td>0x3</td> <td>Auto mode</td> </tr> </tbody> </table>	Value	Description	0x0	Force PFM operation	0x1	Force PWM operation	0x2	Force PWM operation	0x3	Auto mode
Value	Description												
0x0	Force PFM operation												
0x1	Force PWM operation												
0x2	Force PWM operation												
0x3	Auto mode												
[1:0]	RW	CH2_A_MODE	<p>Operation mode selection. Initial value is determined by CONF pin setting at the start-up in CONF_EN = 1</p> <table border="1"> <thead> <tr> <th>Value</th> <th>Description</th> </tr> </thead> <tbody> <tr> <td>0x0</td> <td>Force PFM operation</td> </tr> <tr> <td>0x1</td> <td>Force PWM operation</td> </tr> <tr> <td>0x2</td> <td>Force PWM operation</td> </tr> <tr> <td>0x3</td> <td>Auto mode</td> </tr> </tbody> </table>	Value	Description	0x0	Force PFM operation	0x1	Force PWM operation	0x2	Force PWM operation	0x3	Auto mode
Value	Description												
0x0	Force PFM operation												
0x1	Force PWM operation												
0x2	Force PWM operation												
0x3	Auto mode												

## High-Performance, Dual-Channel DC-DC Converter for Automotive Applications

**Table 52: BUCK\_BUCK2\_5 (0x002D)**

Bit	Type	Symbol	Description																				
[7:0]	RW	CH2_A_VOUT	<p>Output voltage setting A: Initial value is determined by CONF pin setting at the start-up in CONF_EN = 1 From 0.30 V (0x1E) to 1.90 V (0xBE) in steps of 10 mV (default 1.0 V) Write-protected when value is written below 0.30 V or above 1.90 V</p> <table border="1"> <thead> <tr> <th>Value</th> <th>Description</th> </tr> </thead> <tbody> <tr> <td>0x1E</td> <td>0.3</td> </tr> <tr> <td>0x1F</td> <td>0.31</td> </tr> <tr> <td>0x20</td> <td>0.32</td> </tr> <tr> <td colspan="2">Continuing through...</td> </tr> <tr> <td>0x64</td> <td>1</td> </tr> <tr> <td colspan="2">To...</td> </tr> <tr> <td>0xBC</td> <td>1.88</td> </tr> <tr> <td>0xBD</td> <td>1.89</td> </tr> <tr> <td>0xBE</td> <td>1.9</td> </tr> </tbody> </table>	Value	Description	0x1E	0.3	0x1F	0.31	0x20	0.32	Continuing through...		0x64	1	To...		0xBC	1.88	0xBD	1.89	0xBE	1.9
Value	Description																						
0x1E	0.3																						
0x1F	0.31																						
0x20	0.32																						
Continuing through...																							
0x64	1																						
To...																							
0xBC	1.88																						
0xBD	1.89																						
0xBE	1.9																						

**Table 53: BUCK\_BUCK2\_6 (0x002E)**

Bit	Type	Symbol	Description																				
[7:0]	RW	CH2_B_VOUT	<p>Output voltage setting B: Initial value is determined by CONF pin setting at the start-up in CONF_EN = 1 From 0.30 V (0x1E) to 1.90 V (0xBE) in steps of 10 mV (default 1.0 V) Write-protected when value is written below 0.30 V or above 1.90 V</p> <table border="1"> <thead> <tr> <th>Value</th> <th>Description</th> </tr> </thead> <tbody> <tr> <td>0x1E</td> <td>0.3</td> </tr> <tr> <td>0x1F</td> <td>0.31</td> </tr> <tr> <td>0x20</td> <td>0.32</td> </tr> <tr> <td colspan="2">Continuing through...</td> </tr> <tr> <td>0x64</td> <td>1</td> </tr> <tr> <td colspan="2">To...</td> </tr> <tr> <td>0xBC</td> <td>1.88</td> </tr> <tr> <td>0xBD</td> <td>1.89</td> </tr> <tr> <td>0xBE</td> <td>1.9</td> </tr> </tbody> </table>	Value	Description	0x1E	0.3	0x1F	0.31	0x20	0.32	Continuing through...		0x64	1	To...		0xBC	1.88	0xBD	1.89	0xBE	1.9
Value	Description																						
0x1E	0.3																						
0x1F	0.31																						
0x20	0.32																						
Continuing through...																							
0x64	1																						
To...																							
0xBC	1.88																						
0xBD	1.89																						
0xBE	1.9																						

## High-Performance, Dual-Channel DC-DC Converter for Automotive Applications

### 5.1.4 Serialization

**Table 54: OTP\_DEVICE\_ID (0x0048)**

Bit	Type	Symbol	Description
[7:0]	R	DEV_ID	Device ID

**Table 55: OTP\_VARIANT\_ID (0x0049)**

Bit	Type	Symbol	Description
[7:4]	R	MRC	Mask Revision Code
[3:0]	R	VRC	Chip Variant Code

**Table 56: OTP\_CUSTOMER\_ID (0x004A)**

Bit	Type	Symbol	Description
[7:0]	R	CUST_ID	Customer ID

**Table 57: OTP\_CONFIG\_ID (0x004B)**

Bit	Type	Symbol	Description
[7:0]	R	CONFIG_REV	OTP Variant

High-Performance, Dual-Channel DC-DC Converter for Automotive Applications

6 Package Information

6.1 Package Outlines

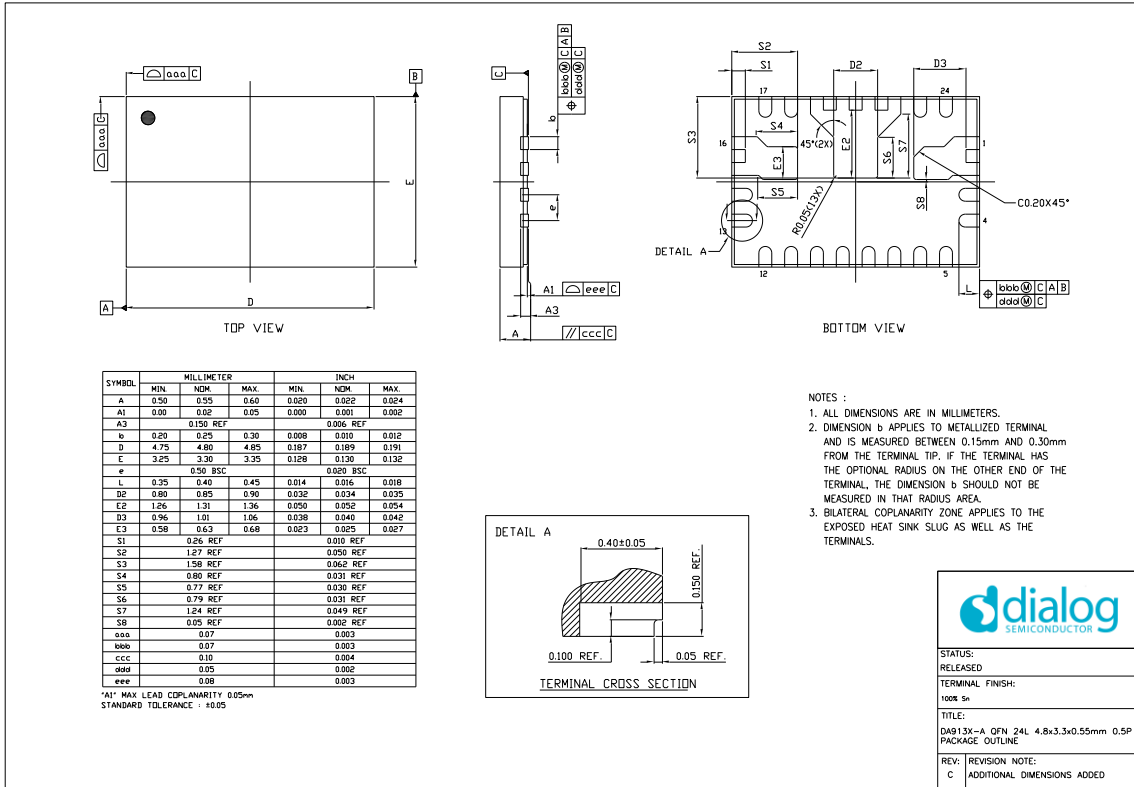

Figure 19: Package Outline Drawing

## High-Performance, Dual-Channel DC-DC Converter for Automotive Applications

### 6.2 Package Marking

Package Marking		
A1 Corner >	Marking Content	Format
1st	•	Pin 1 ID
2nd	<b>D A 9 1 3 2</b>	Orientation/Part No.
3rd	<b>x x A T y y</b>	OTP/Option/Year
4th	<b>W W z z z z</b>	Date Code
Date Code Format: yy = Year, ww = Week, zzzz = Traceability		
xx identifies the OTP Variant		
A or AT optionally indicate the Automotive and Automotive high temp test options.		

### 6.3 Moisture Sensitivity Level

The moisture sensitivity level (MSL) is an indicator for the maximum allowable time period (floor lifetime) in which a moisture sensitive plastic device, once removed from the dry bag, can be exposed to an environment with a specified maximum temperature and a maximum relative humidity before the solder reflow process. The MSL classification is defined in [Table 58](#).

For detailed information on MSL levels refer to the IPC/JEDEC standard J-STD-020, which can be downloaded from <http://www.jedec.org>.

The FCQFN package is qualified for MSL 3.

**Table 58: MSL Classification**

MSL Level	Floor Lifetime	Conditions
MSL 4	72 hours	30 °C / 60 % RH
MSL 3	168 hours	30 °C / 60 % RH
MSL 2A	4 weeks	30 °C / 60 % RH
MSL 2	1 year	30 °C / 60 % RH
MSL 1	Unlimited	30 °C / 60 % RH

### 6.4 Soldering Information

Refer to the IPC/JEDEC standard J-STD-020 for relevant soldering information. This document can be downloaded from <http://www.jedec.org>.

## High-Performance, Dual-Channel DC-DC Converter for Automotive Applications

### 7 Ordering Information

The ordering number consists of the part number followed by a suffix indicating the packing method. For details and availability, please consult your Dialog Semiconductor [local sales representative](#).

**Table 59: Ordering Information**

Part Number	Package	Package Description	MOQ	Comment
DA9132-AxxRT2-A	24 FCQFN wettable flanks, 3.3 x 4.8	T&R, 4800 pcs	3 Reels - 14400	AEC-Q100 Grade 2
DA9132-AxxRT1-A	24 FCQFN wettable flanks, 3.3 x 4.8	Tray, 490 pcs	30 Trays - 14700 pcs	AEC-Q100 Grade 2
DA9132-AxxRT2-AT	24 FCQFN wettable flanks, 3.3 x 4.8	T&R, 4800 pcs	3 Reels - 14400	AEC-Q100 Grade 2
DA9132-AxxRT1-AT	24 FCQFN wettable flanks, 3.3 x 4.8	Tray, 490 pcs	30 Trays - 14700 pcs	AEC-Q100 Grade 2

## High-Performance, Dual-Channel DC-DC Converter for Automotive Applications

### 8 Application Information

The following recommended components are examples selected from requirements of a typical application.

#### 8.1 Capacitor Selection

Ceramic capacitors are used as bypass capacitors at all VDD and output rails. When selecting a capacitor, especially for types with high capacitance at smallest physical dimension, the DC bias characteristic has to be taken into account.

**Table 60: Recommended Automotive Grade Capacitor Types**

Application	Value (μF)	Size	Temp. Char.	Tol. (%)	V-Rate (V)	Type
VOUT output bypass	10	0805	X7R ±15%	±10	6.3	TDK CGA4J1X7R0J106K125AC
PVDDx bypass	10	3216	X7R ±15%	±10	16	Murata GCM31CR71C106KA64L
AVDD bypass	1	0805	X7R ±15%	±10	50	Murata GCM21BR71H105KA03L

#### 8.2 Inductor Selection

Inductors should be selected based on the following parameters:

- Rated maximum current  
Usually a coil provides two current limits: ISAT specifies the maximum current at which the inductance drops by 30 % of the nominal value, and IMAX is defined by the maximum power dissipation and is applied to the effective current.
- DC resistance  
Critical for the converter efficiency and should therefore be minimized.

**Table 61: Recommended Inductor Types**

Value (μH)	Size (mm)	IMAX (DC) (A)	ISAT (A)	Tol. (%)	DC Resistance (mΩ)	Type
0.22	2.5 x 2.0 x 1.2	6.7	8	20	8	TDK TFM252012ALMAR22MTAA
0.47	2.5 x 2.0 x 1.2	4.9	5.8	20	8	TDK TFM252012ALMAR47MTAA

## High-Performance, Dual-Channel DC-DC Converter for Automotive Applications

### Status Definitions

Revision	Datasheet Status	Product Status	Definition
1.<n>	Target	Development	This datasheet contains the design specifications for product development. Specifications may be changed in any manner without notice.
2.<n>	Preliminary	Qualification	This datasheet contains the specifications and preliminary characterization data for products in pre-production. Specifications may be changed at any time without notice in order to improve the design.
3.<n>	Final	Production	This datasheet contains the final specifications for products in volume production. The specifications may be changed at any time in order to improve the design, manufacturing and supply. Major specification changes are communicated via Customer Product Notifications. Datasheet changes are communicated via <a href="http://www.dialog-semiconductor.com">www.dialog-semiconductor.com</a> .
4.<n>	Obsolete	Archived	This datasheet contains the specifications for discontinued products. The information is provided for reference only.

### RoHS Compliance

Dialog Semiconductor's suppliers certify that its products are in compliance with the requirements of Directive 2011/65/EU of the European Parliament on the restriction of the use of certain hazardous substances in electrical and electronic equipment. RoHS certificates from our suppliers are available on request.



## High-Performance, Dual-Channel DC-DC Converter for Automotive Applications

### Important Notice and Disclaimer

RENESAS ELECTRONICS CORPORATION AND ITS SUBSIDIARIES ("RENESAS") PROVIDES TECHNICAL SPECIFICATIONS AND RELIABILITY DATA (INCLUDING DATASHEETS), DESIGN RESOURCES (INCLUDING REFERENCE DESIGNS), APPLICATION OR OTHER DESIGN ADVICE, WEB TOOLS, SAFETY INFORMATION, AND OTHER RESOURCES "AS IS" AND WITH ALL FAULTS, AND DISCLAIMS ALL WARRANTIES, EXPRESS OR IMPLIED, INCLUDING, WITHOUT LIMITATION, ANY IMPLIED WARRANTIES OF MERCHANTABILITY, FITNESS FOR A PARTICULAR PURPOSE, OR NON-INFRINGEMENT OF THIRD PARTY INTELLECTUAL PROPERTY RIGHTS.

These resources are intended for developers skilled in the art designing with Renesas products. You are solely responsible for (1) selecting the appropriate products for your application, (2) designing, validating, and testing your application, and (3) ensuring your application meets applicable standards, and any other safety, security, or other requirements. These resources are subject to change without notice. Renesas grants you permission to use these resources only for development of an application that uses Renesas products. Other reproduction or use of these resources is strictly prohibited. No license is granted to any other Renesas intellectual property or to any third party intellectual property. Renesas disclaims responsibility for, and you will fully indemnify Renesas and its representatives against, any claims, damages, costs, losses, or liabilities arising out of your use of these resources. Renesas' products are provided only subject to Renesas' Terms and Conditions of Sale or other applicable terms agreed to in writing. No use of any Renesas resources expands or otherwise alters any applicable warranties or warranty disclaimers for these products.

© 2022 Renesas Electronics Corporation. All rights reserved.

(Rev.1.0 Mar 2020)

## Corporate Headquarters

TOYOSU FORESIA, 3-2-24 Toyosu

Koto-ku, Tokyo 135-0061, Japan

[www.renesas.com](http://www.renesas.com)

### Contact Information

For further information on a product, technology, the most up-to-date version of a document, or your nearest sales office, please visit:

<https://www.renesas.com/contact/>

### Trademarks

Renesas and the Renesas logo are trademarks of Renesas Electronics Corporation. All trademarks and registered trademarks are the property of their respective owners.

(Rev.1.0 Mar 2020)

## Notice

1. Descriptions of circuits, software and other related information in this document are provided only to illustrate the operation of semiconductor products and application examples. You are fully responsible for the incorporation or any other use of the circuits, software, and information in the design of your product or system. Renesas Electronics disclaims any and all liability for any losses and damages incurred by you or third parties arising from the use of these circuits, software, or information.
2. Renesas Electronics hereby expressly disclaims any warranties against and liability for infringement or any other claims involving patents, copyrights, or other intellectual property rights of third parties, by or arising from the use of Renesas Electronics products or technical information described in this document, including but not limited to, the product data, drawings, charts, programs, algorithms, and application examples.
3. No license, express, implied or otherwise, is granted hereby under any patents, copyrights or other intellectual property rights of Renesas Electronics or others.
4. You shall be responsible for determining what licenses are required from any third parties, and obtaining such licenses for the lawful import, export, manufacture, sales, utilization, distribution or other disposal of any products incorporating Renesas Electronics products, if required.
5. You shall not alter, modify, copy, or reverse engineer any Renesas Electronics product, whether in whole or in part. Renesas Electronics disclaims any and all liability for any losses or damages incurred by you or third parties arising from such alteration, modification, copying or reverse engineering.
6. Renesas Electronics products are classified according to the following two quality grades: "Standard" and "High Quality". The intended applications for each Renesas Electronics product depends on the product's quality grade, as indicated below.

"Standard": Computers; office equipment; communications equipment; test and measurement equipment; audio and visual equipment; home electronic appliances; machine tools; personal electronic equipment; industrial robots; etc.

"High Quality": Transportation equipment (automobiles, trains, ships, etc.); traffic control (traffic lights); large-scale communication equipment; key financial terminal systems; safety control equipment; etc.

Unless expressly designated as a high reliability product or a product for harsh environments in a Renesas Electronics data sheet or other Renesas Electronics document, Renesas Electronics products are not intended or authorized for use in products or systems that may pose a direct threat to human life or bodily injury (artificial life support devices or systems; surgical implantations; etc.), or may cause serious property damage (space system; undersea repeaters; nuclear power control systems; aircraft control systems; key plant systems; military equipment; etc.). Renesas Electronics disclaims any and all liability for any damages or losses incurred by you or any third parties arising from the use of any Renesas Electronics product that is inconsistent with any Renesas Electronics data sheet, user's manual or other Renesas Electronics document.
7. No semiconductor product is absolutely secure. Notwithstanding any security measures or features that may be implemented in Renesas Electronics hardware or software products, Renesas Electronics shall have absolutely no liability arising out of any vulnerability or security breach, including but not limited to any unauthorized access to or use of a Renesas Electronics product or a system that uses a Renesas Electronics product. RENESAS ELECTRONICS DOES NOT WARRANT OR GUARANTEE THAT RENESAS ELECTRONICS PRODUCTS, OR ANY SYSTEMS CREATED USING RENESAS ELECTRONICS PRODUCTS WILL BE INVULNERABLE OR FREE FROM CORRUPTION, ATTACK, VIRUSES, INTERFERENCE, HACKING, DATA LOSS OR THEFT, OR OTHER SECURITY INTRUSION ("Vulnerability Issues"). RENESAS ELECTRONICS DISCLAIMS ANY AND ALL RESPONSIBILITY OR LIABILITY ARISING FROM OR RELATED TO ANY VULNERABILITY ISSUES. FURTHERMORE, TO THE EXTENT PERMITTED BY APPLICABLE LAW, RENESAS ELECTRONICS DISCLAIMS ANY AND ALL WARRANTIES, EXPRESS OR IMPLIED, WITH RESPECT TO THIS DOCUMENT AND ANY RELATED OR ACCOMPANYING SOFTWARE OR HARDWARE, INCLUDING BUT NOT LIMITED TO THE IMPLIED WARRANTIES OF MERCHANTABILITY, OR FITNESS FOR A PARTICULAR PURPOSE.
8. When using Renesas Electronics products, refer to the latest product information (data sheets, user's manuals, application notes, "General Notes for Handling and Using Semiconductor Devices" in the reliability handbook, etc.), and ensure that usage conditions are within the ranges specified by Renesas Electronics with respect to maximum ratings, operating power supply voltage range, heat dissipation characteristics, installation, etc. Renesas Electronics disclaims any and all liability for any malfunctions, failure or accident arising out of the use of Renesas Electronics products outside of such specified ranges.
9. Although Renesas Electronics endeavors to improve the quality and reliability of Renesas Electronics products, semiconductor products have specific characteristics, such as the occurrence of failure at a certain rate and malfunctions under certain use conditions. Unless designated as a high reliability product or a product for harsh environments in a Renesas Electronics data sheet or other Renesas Electronics document, Renesas Electronics products are not subject to radiation resistance design. You are responsible for implementing safety measures to guard against the possibility of bodily injury, injury or damage caused by fire, and/or danger to the public in the event of a failure or malfunction of Renesas Electronics products, such as safety design for hardware and software, including but not limited to redundancy, fire control and malfunction prevention, appropriate treatment for aging degradation or any other appropriate measures. Because the evaluation of microcomputer software alone is very difficult and impractical, you are responsible for evaluating the safety of the final products or systems manufactured by you.
10. Please contact a Renesas Electronics sales office for details as to environmental matters such as the environmental compatibility of each Renesas Electronics product. You are responsible for carefully and sufficiently investigating applicable laws and regulations that regulate the inclusion or use of controlled substances, including without limitation, the EU RoHS Directive, and using Renesas Electronics products in compliance with all these applicable laws and regulations. Renesas Electronics disclaims any and all liability for damages or losses occurring as a result of your noncompliance with applicable laws and regulations.
11. Renesas Electronics products and technologies shall not be used for or incorporated into any products or systems whose manufacture, use, or sale is prohibited under any applicable domestic or foreign laws or regulations. You shall comply with any applicable export control laws and regulations promulgated and administered by the governments of any countries asserting jurisdiction over the parties or transactions.
12. It is the responsibility of the buyer or distributor of Renesas Electronics products, or any other party who distributes, disposes of, or otherwise sells or transfers the product to a third party, to notify such third party in advance of the contents and conditions set forth in this document.
13. This document shall not be reprinted, reproduced or duplicated in any form, in whole or in part, without prior written consent of Renesas Electronics.
14. Please contact a Renesas Electronics sales office if you have any questions regarding the information contained in this document or Renesas Electronics products.

(Note1) "Renesas Electronics" as used in this document means Renesas Electronics Corporation and also includes its directly or indirectly controlled subsidiaries.

(Note2) "Renesas Electronics product(s)" means any product developed or manufactured by or for Renesas Electronics.

(Rev.5.0-1 October 2020)

## Corporate Headquarters

TOYOSU FORESIA, 3-2-24 Toyosu,  
Koto-ku, Tokyo 135-0061, Japan  
[www.renesas.com](http://www.renesas.com)

## Trademarks

Renesas and the Renesas logo are trademarks of Renesas Electronics Corporation. All trademarks and registered trademarks are the property of their respective owners.

## Contact Information

For further information on a product, technology, the most up-to-date version of a document, or your nearest sales office, please visit:  
[www.renesas.com/contact/](http://www.renesas.com/contact/)