

## Description

The 9ZXL revision E family of Zero-Delay/Fanout Buffers (ZDB, FOB) with SMBus Write Protect are 2nd-generation enhanced performance buffers for PCIe and CPU applications. The devices have hardware SMBUS write protection to prevent accidental writes. The family meets all published QPI/UPI, DB2000Q and PCIe Gen1–5 jitter specifications. Devices range from 6 to 12 outputs, with each output having an OE# pin to support the PCIe CLKREQ# function for low power states. All devices meet DB2000Q, DB1200ZL and DB800ZL jitter and skew requirements.

## PCIe Clocking Architectures

- Common Clocked (CC)
- Independent Reference (IR) with and without spread spectrum (SRIS, SRNS)

## Key Specifications

- Fanout Buffer Mode additive phase jitter:
  - PCIe Gen5 CC, UPI  $\geq 20\text{Gb/s}$  < 24fs RMS
  - DB2000Q additive jitter < 39fs RMS
  - QPI/UPI 11.4GB/s < 40fs RMS
  - IF-UPI additive jitter < 70fs RMS
- ZDB Mode phase jitter:
  - PCIe Gen5 CC, UPI  $\geq 20\text{Gb/s}$  < 22fs RMS
  - QPI/UPI 11.4GB/s < 120fs RMS
  - IF-UPI additive jitter < 130fs RMS
- Cycle-to-cycle jitter < 50ps
- Output-to-output skew < 50ps

## Block Diagram

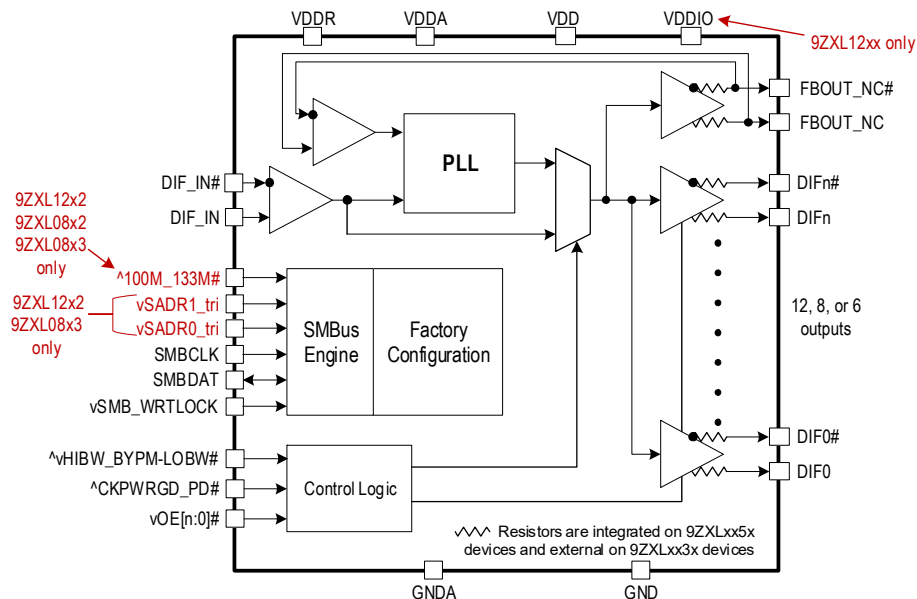

## Features

- SMBus Write Protect pin prevents SMBus against accidental writes
- 6–12 Low-power HCSL (LP-HCSL) outputs
- Integrated terminations eliminate up to 4 resistors per output pair
- Dedicated OE# pins support PCIe CLKREQ# function
- Up to 9 selectable SMBus addresses (9ZXL12xx, 9ZXL0853)
- Selectable PLL bandwidths minimizes jitter peaking in cascaded PLL topologies
- Hardware/SMBus control of ZDB and FOB modes allow change without power cycle
- Spread spectrum compatible
- 1–400MHz FOB operation (all devices)
- 100MHz and 133.33MHz ZDB mode (9ZXL12xx, 9ZXL08xx)
- 100MHz ZDB mode (9ZXL06xx)
- 40°C to +85°C operating temperature range
- Packages: See [Ordering Information](#) for more details

## Typical Applications

- Servers/High-performance Computing
- nVME Storage
- Networking
- Accelerators
- Industrial Control

## Contents

Description .....	1
PCIe Clocking Architectures .....	1
Key Specifications .....	1
Features .....	1
Typical Applications .....	1
Block Diagram .....	1
Pin Assignments .....	3
9ZXL06x2E Pin Assignment .....	3
9ZXL08x2E Pin Assignment .....	4
9ZXL0853E Pin Assignment .....	5
9ZXL12x2E Pin Assignment .....	6
Pin Descriptions .....	7
Absolute Maximum Ratings .....	10
Thermal Characteristics .....	10
Electrical Characteristics .....	11
Power Management .....	19
Test Loads .....	20
General SMBus Serial Interface Information .....	22
How to Write .....	22
How to Read .....	22
Package Outline Drawings .....	26
Marking Diagrams .....	26
9ZXL06x2E .....	26
9ZXL08xxE .....	27
9ZXL12x2E .....	27
Ordering Information .....	28
Revision History .....	29

# Pin Assignments

## 9ZXL06x2E Pin Assignment

Figure 1. Pin Assignment for 5 × 5 mm 40-VFQFPN Package – Top View

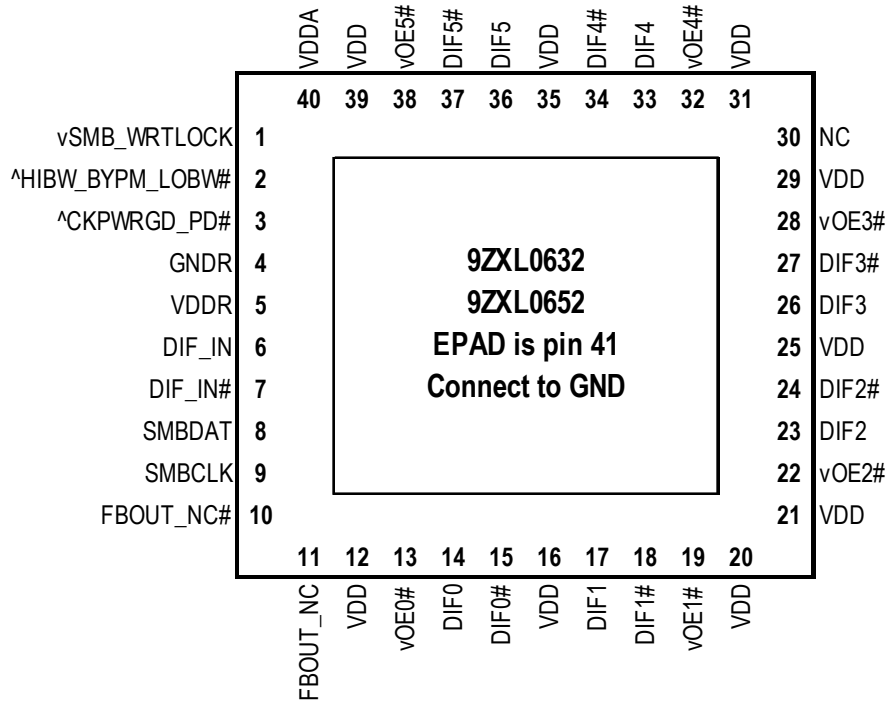

### 5 x 5 mm, 0.40mm pitch 40-VFQFPN

Pins with ^ prefix have internal 120kohm pull-up  
 Pins with v prefix have internal 120kohm pull-down

## 9ZXL08x2E Pin Assignment

Figure 2. Pin Assignment for 6 × 6 mm 48-VFQFPN Package – Top View

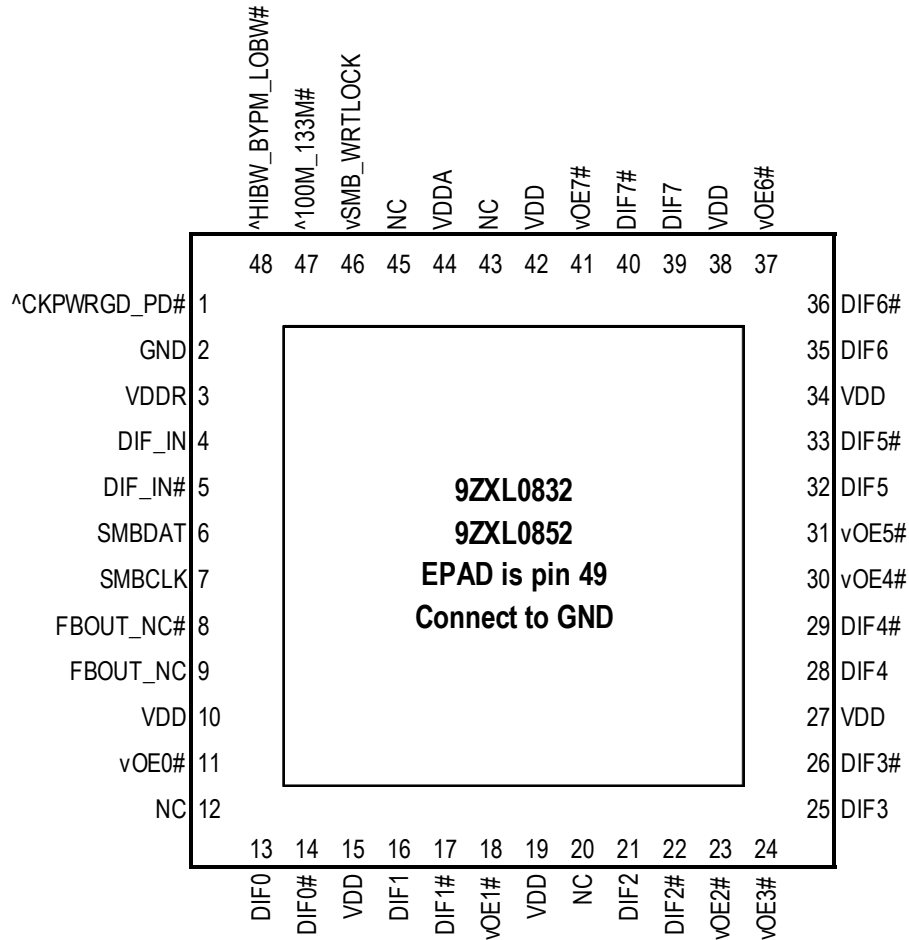

### 6 x 6 mm, 0.4mm pitch 48-VFQFPN

Pins with ^ prefix have internal 120kohm pull-up  
Pins with v prefix have internal 120kohm pull-down

### 9ZXL0853E Pin Assignment

Figure 3. Pin Assignment for 6 × 6 mm 48-VFQFPN Package – Top View

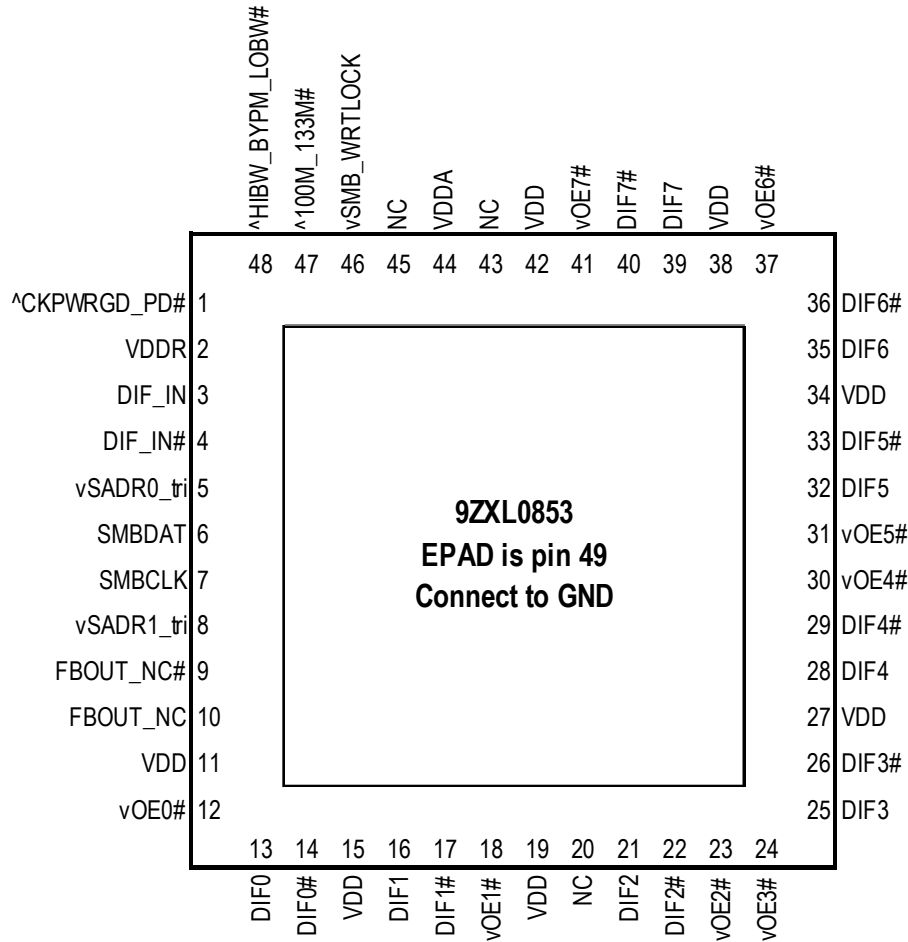

**6 x 6 mm, 0.4mm pitch 48-VFQFPN**

Pins with ^ prefix have internal 120kohm pull-up  
 Pins with v prefix have internal 120kohm pull-down

### 9ZXL12x2E Pin Assignment

Figure 4. Pin Assignment for 9 × 9 mm 64-VFQFPN Package – Top View

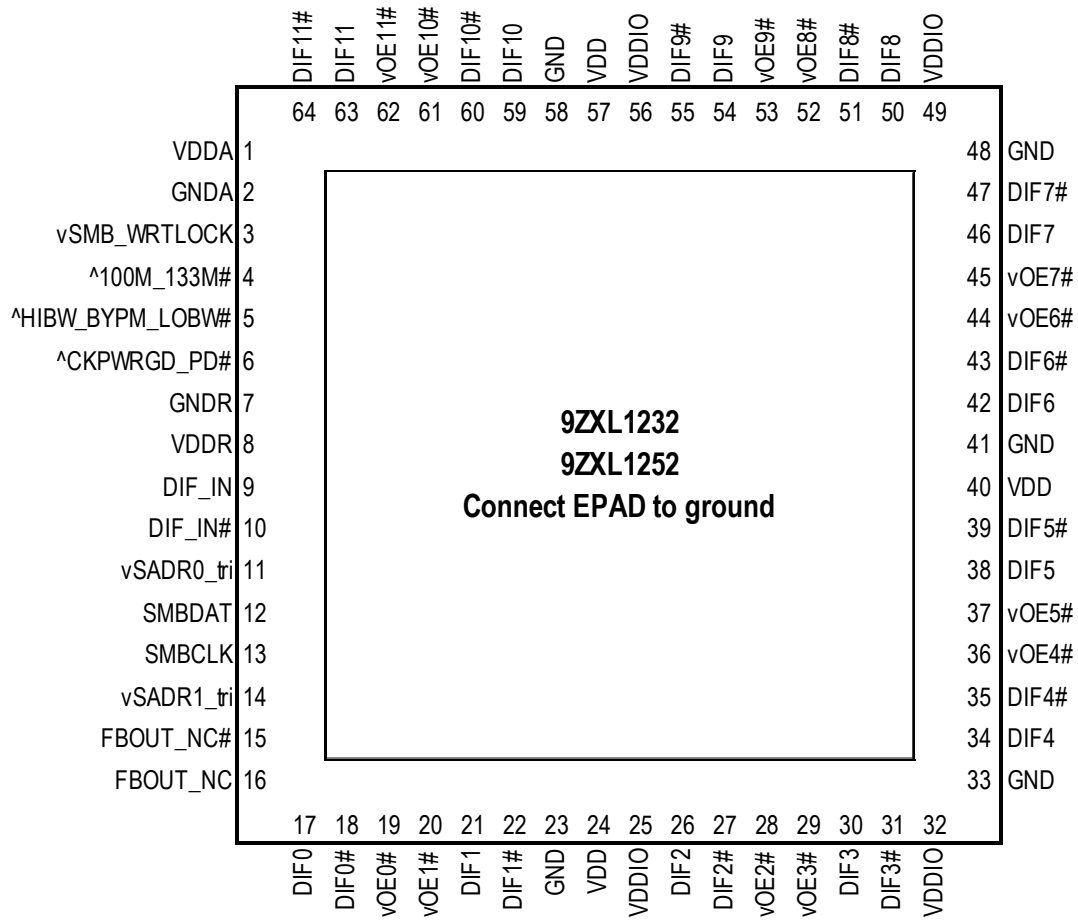

**9 x 9 mm, 0.5mm pitch 64-VFQFPN**

Pins with ^ prefix have internal 120kohm pull-up  
 Pins with v prefix have internal 120kohm pull-down

## Pin Descriptions

**Table 1. Pin Descriptions**

Name	Type	Description	9ZXL12x2 Pin No.	9ZXL08x2 Pin No.	9ZXL0853 Pin No.	9ZXL06x2 Pin No.
^100M_133M#	Latched In	3.3V Input to select operating frequency. This pin has an internal pull-up resistor. See <a href="#">Frequency Selection (PLL Mode)</a> table for definition.	4	47	47	—
^CKPWRGD_PD#	Input	Input notifies device to sample latched inputs and start up on first high assertion. Low enters Power Down Mode, subsequent high assertions exit Power Down Mode. This pin has internal pull-up resistor.	6	1	1	3
^HIBW_BYPM_LO BW#	Latched In	Tri-level input to select High BW, Bypass or Low BW Mode. This pin has an internal pull-up resistor. See <a href="#">PLL Operating Mode</a> table for details.	5	48	48	2
DIF_IN	Input	HCSL true input.	9	4	3	6
DIF_IN#	Input	HCSL complementary input.	10	5	4	7
DIF0	Output	Differential true clock output.	17	13	13	14
DIF0#	Output	Differential complementary clock output.	18	14	14	15
DIF1	Output	Differential true clock output.	21	16	16	17
DIF1#	Output	Differential complementary clock output.	22	17	17	18
DIF10	Output	Differential true clock output.	59	—	—	—
DIF10#	Output	Differential complementary clock output.	60	—	—	—
DIF11	Output	Differential true clock output.	63	—	—	—
DIF11#	Output	Differential complementary clock output.	64	—	—	—
DIF2	Output	Differential true clock output.	26	21	21	23
DIF2#	Output	Differential complementary clock output.	27	22	22	24
DIF3	Output	Differential true clock output.	30	25	25	26
DIF3#	Output	Differential complementary clock output.	31	26	26	27
DIF4	Output	Differential true clock output.	34	28	28	33
DIF4#	Output	Differential complementary clock output.	35	29	29	34
DIF5	Output	Differential true clock output.	38	32	32	36
DIF5#	Output	Differential complementary clock output.	39	33	33	37
DIF6	Output	Differential true clock output.	42	35	35	—
DIF6#	Output	Differential complementary clock output.	43	36	36	—
DIF7	Output	Differential true clock output.	46	39	39	—
DIF7#	Output	Differential complementary clock output.	47	40	40	—
DIF8	Output	Differential true clock output.	50	—	—	—
DIF8#	Output	Differential complementary clock output.	51	—	—	—
DIF9	Output	Differential true clock output.	54	—	—	—
DIF9#	Output	Differential complementary clock output.	55	—	—	—

**Table 1. Pin Descriptions (Cont.)**

Name	Type	Description	9ZXL12x2 Pin No.	9ZXL08x2 Pin No.	9ZXL0853 Pin No.	9ZXL06x2 Pin No.
EPAD	GND	Connect EPAD to ground.	65	49	49	41
FBOUT_NC	Output	True half of differential feedback output. This pin should NOT be connected to anything outside the chip. It exists to provide delay path matching to get 0 propagation delay.	16	9	10	11
FBOUT_NC#	Output	Complementary half of differential feedback output. This pin should NOT be connected to anything outside the chip. It exists to provide delay path matching to get 0 propagation delay.	15	8	9	10
GND	GND	Ground pin.	23	49	49	41
GND	GND	Ground pin.	33	49	49	41
GND	GND	Ground pin.	41	49	49	—
GND	GND	Ground pin.	48	49	49	—
GND	GND	Ground pin.	58	—	—	—
GND	GND	Ground pin for the PLL core.	2	49	49	41
GND	GND	Analog ground pin for the differential input (receiver).	7	2	49	4
NC	—	No connect.		12,20,43,45	20,43,45	30
SMBCLK	Input	Clock pin of SMBUS circuitry.	13	7	7	9
SMBDAT	I/O	Data pin of SMBUS circuitry.	12	6	6	8
VDD	Power	Power supply, nominally 3.3V.	24	10,15,19,27, 34,38,42	11,15,19,27, 34,38,42	12,16,20, 21,25,29, 31,35,39
VDD	Power	Power supply, nominally 3.3V.	40	—	—	—
VDD	Power	Power supply, nominally 3.3V.	57	—	—	—
VDDA	Power	Power supply for PLL core.	1	44	44	40
VDDIO	Power	Power supply for differential outputs.	25	—	—	—
VDDIO	Power	Power supply for differential outputs.	32	—	—	—
VDDIO	Power	Power supply for differential outputs.	49	—	—	—
VDDIO	Power	Power supply for differential outputs.	56	—	—	—
VDDR	Power	Power supply for differential input clock (receiver). This VDD should be treated as an analog power rail and filtered appropriately. Nominally 3.3V.	8	3	2	5
vOE0#	Input	Active low input for enabling output 0. This pin has an internal pull-down. 1 = disable output, 0 = enable output.	19	11	12	13
vOE1#	Input	Active low input for enabling output 1. This pin has an internal pull-down. 1 = disable output, 0 = enable output.	20	18	18	19



**Table 1. Pin Descriptions (Cont.)**

Name	Type	Description	9ZXL12x2 Pin No.	9ZXL08x2 Pin No.	9ZXL0853 Pin No.	9ZXL06x2 Pin No.
vOE10#	Input	Active low input for enabling output 10. This pin has an internal pull-down. 1 = disable output, 0 = enable output.	61	—	—	—
vOE11#	Input	Active low input for enabling output 11. This pin has an internal pull-down. 1 = disable output, 0 = enable output.	62	—	—	—
vOE2#	Input	Active low input for enabling output 2. This pin has an internal pull-down. 1 = disable output, 0 = enable output.	28	23	23	22
vOE3#	Input	Active low input for enabling output 3. This pin has an internal pull-down. 1 = disable output, 0 = enable output.	29	24	24	28
vOE4#	Input	Active low input for enabling output 4. This pin has an internal pull-down. 1 = disable output, 0 = enable output.	36	30	30	32
vOE5#	Input	Active low input for enabling output 5. This pin has an internal pull-down. 1 = disable output, 0 = enable output.	37	31	31	38
vOE6#	Input	Active low input for enabling output 6. This pin has an internal pull-down. 1 = disable output, 0 = enable output.	44	37	37	—
vOE7#	Input	Active low input for enabling output 7. This pin has an internal pull-down. 1 = disable output, 0 = enable output.	45	41	41	—
vOE8#	Input	Active low input for enabling output 8. This pin has an internal pull-down. 1 = disable output, 0 = enable output.	52	—	—	—
vOE9#	Input	Active low input for enabling output 9. This pin has an internal pull-down. 1 = disable output, 0 = enable output.	53	—	—	—
vSADR0_tri	Input	SMBus address bit. This is a tri-level input that works in conjunction with other SADR pins, if present, to decode SMBus Addresses. It has an internal pull-down resistor. See the <a href="#">SMBus Addressing</a> table.	11	—	5	—
vSADR1_tri	Input	SMBus address bit. This is a tri-level input that works in conjunction with other SADR pins, if present, to decode SMBus Addresses. It has an internal pull-down resistor. See the <a href="#">SMBus Addressing</a> table.	14	—	8	—
vSMB_WRTLOCK	Input	This pin prevents SMBus writes when asserted. SMBus reads are not affected. This pin has an internal pull-down. 0 = SMBus writes allows, 1 = SMBus writes blocked.	3	46	46	1

## Absolute Maximum Ratings

Stresses above the ratings listed below can cause permanent damage to the 9ZXL06x2E/9ZXL08xxE/9ZXL12x2E. These ratings, which are standard values for Renesas commercially rated parts, are stress ratings only. Functional operation of the device at these or any other conditions above those indicated in the operational sections of the specifications is not implied. Exposure to absolute maximum rating conditions for extended periods can affect product reliability. Electrical parameters are guaranteed only over the recommended operating temperature range.

**Table 2. Absolute Maximum Ratings**

Parameter	Symbol	Conditions	Minimum	Typical	Maximum	Units	Notes
Supply Voltage	VDDx				3.9	V	1,2
Input Low Voltage	V <sub>IL</sub>		GND - 0.5			V	1
Input High Voltage	V <sub>IH</sub>	Except for SMBus interface.			V <sub>DD</sub> + 0.5	V	1,3
Input High Voltage	V <sub>IHSMB</sub>	SMBus clock and data pins.			3.9	V	1
Storage Temperature	T <sub>s</sub>		-65		150	°C	1
Junction Temperature	T <sub>j</sub>				125	°C	1
Input ESD Protection	ESD prot	Human Body Model.	2500			V	1

<sup>1</sup> Guaranteed by design and characterization, not 100% tested in production.

<sup>2</sup> Operation under these conditions is neither implied nor guaranteed.

<sup>3</sup> Not to exceed 3.9V.

## Thermal Characteristics

**Table 3. Thermal Characteristics**

Parameter	Symbol	Conditions	Package	Typical Values	Units	Notes
9ZXL12 Thermal Resistance	$\theta_{JC}$	Junction to case.	NLG64	14	°C/W	1
	$\theta_{Jb}$	Junction to base.		1	°C/W	1
	$\theta_{JA0}$	Junction to air, still air.		28	°C/W	1
	$\theta_{JA1}$	Junction to air, 1 m/s air flow.		21	°C/W	1
	$\theta_{JA3}$	Junction to air, 3 m/s air flow.		19	°C/W	1
	$\theta_{JA5}$	Junction to air, 5 m/s air flow.		18	°C/W	1
9ZXL08 Thermal Resistance	$\theta_{JC}$	Junction to case.	NDG48	19	°C/W	1
	$\theta_{Jb}$	Junction to base.		0	°C/W	1
	$\theta_{JA0}$	Junction to air, still air.		30	°C/W	1
	$\theta_{JA1}$	Junction to air, 1 m/s air flow.		23	°C/W	1
	$\theta_{JA3}$	Junction to air, 3 m/s air flow.		20	°C/W	1
	$\theta_{JA5}$	Junction to air, 5 m/s air flow.		19	°C/W	1

**Table 3. Thermal Characteristics (Cont.)**

Parameter	Symbol	Conditions	Package	Typical Values	Units	Notes
9ZXL06 Thermal Resistance	$\theta_{JC}$	Junction to case.	NDG40	32	°C/W	1
	$\theta_{Jb}$	Junction to base.		2	°C/W	1
	$\theta_{JA0}$	Junction to air, still air.		44	°C/W	1
	$\theta_{JA1}$	Junction to air, 1 m/s air flow.		37	°C/W	1
	$\theta_{JA3}$	Junction to air, 3 m/s air flow.		33	°C/W	1
	$\theta_{JA5}$	Junction to air, 5 m/s air flow.		31	°C/W	1

<sup>1</sup> EPAD soldered to ground.

## Electrical Characteristics

$T_A = T_{AMB}$ . Supply voltages per normal operation conditions; see [Test Loads](#) for loading conditions.

**Table 4. SMBus Parameters**

Parameter	Symbol	Conditions	Minimum	Typical	Maximum	Units	Notes
SMBus Input Low Voltage	$V_{ILSMB}$				0.8	V	
SMBus Input High Voltage	$V_{IHSMB}$		2.1		$V_{DDSMB}$	V	
SMBus Output Low Voltage	$V_{OLSMB}$	At $I_{PULLUP}$ .			0.4	V	
SMBus Sink Current	$I_{PULLUP}$	At $V_{OL}$ .	4			mA	
Nominal Bus Voltage	$V_{DDSMB}$		2.7		3.6	V	1
SCLK/SDATA Rise Time	$t_{RSMB}$	(Max $V_{IL} - 0.15V$ ) to (Min $V_{IH} + 0.15V$ ).			1000	ns	1
SCLK/SDATA Fall Time	$t_{FSMB}$	(Min $V_{IH} + 0.15V$ ) to (Max $V_{IL} - 0.15V$ ).			300	ns	1
SMBus Operating Frequency	$f_{SMB}$	SMBus operating frequency.			400	kHz	5

<sup>1</sup> Guaranteed by design and characterization, not 100% tested in production.

<sup>2</sup> Control input must be monotonic from 20% to 80% of input swing.

<sup>3</sup> Time from deassertion until outputs are > 200mV.

<sup>4</sup> DIF\_IN input.

<sup>5</sup> The differential input clock must be running for the SMBus to be active.

**Table 5. DIF\_IN Clock Input Parameters**

Parameter	Symbol	Conditions	Minimum	Typical	Maximum	Units	Notes
Input Crossover Voltage – DIF_IN	$V_{CROSS}$	Crossover voltage.	150		900	mV	1
Input Swing – DIF_IN	$V_{SWING}$	Differential value.	300			mV	1
Input Slew Rate – DIF_IN	$dv/dt$	Measured differentially.	0.4		8	V/ns	1,2
Input Leakage Current	$I_{IN}$	$V_{IN} = V_{DD}$ , $V_{IN} = GND$ .	-5		5	μA	
Input Duty Cycle	$d_{tIn}$	Measurement from differential waveform.	45		55	%	1
Input Jitter – Cycle to Cycle	$J_{DIFIn}$	Differential measurement.	0		125	ps	1

<sup>1</sup> Guaranteed by design and characterization, not 100% tested in production.

<sup>2</sup> Slew rate measured through ±75mV window centered around differential zero.

**Table 6. Input/Supply/Common Parameters**

$T_{AMB}$  = over the specified operating range. Supply voltages per normal operation conditions; see [Test Loads](#) for loading conditions.

Parameter	Symbol	Conditions	Minimum	Typical	Maximum	Units	Notes
Supply Voltage	$V_{DDX}$	Supply voltage for core and analog.	3.135	3.3	3.465	V	
Output Supply Voltage	$V_{DDIO}$	Supply voltage for DIF outputs, if present.	0.95	1.05	3.465	V	5
Ambient Operating Temperature	$T_{AMB}$	Extended Industrial range ( $T_{EXIND}$ ).	-40	25	105	°C	7
		Industrial range ( $T_{IND}$ ).	-40	25	85	°C	
Input High Voltage	$V_{IH}$	Single-ended inputs, except SMBus, tri-level inputs.	2		$V_{DD} + 0.3$	V	
Input Low Voltage	$V_{IL}$	Single-ended inputs, except SMBus, tri-level inputs.	GND - 0.3		0.8	V	
Input High Voltage	$V_{IH}$	Tri-level inputs.	2.2		$V_{DD} + 0.3$	V	
Input Mid Voltage	$V_{IM}$	Tri-level inputs.	1.2	$V_{DD}/2$	1.8	V	
Input Low Voltage	$V_{IL}$	Tri-level inputs.	GND - 0.3		0.8	V	
Input Current	$I_{IN}$	Single-ended inputs, $V_{IN} = \text{GND}$ , $V_{IN} = V_{DD}$ .	-5		5	$\mu\text{A}$	
	$I_{INP}$	Single-ended inputs. $V_{IN} = 0 \text{ V}$ ; inputs with internal pull-up resistors. $V_{IN} = V_{DD}$ ; inputs with internal pull-down resistors.	-50		50	$\mu\text{A}$	
Input Frequency	$F_{ibyp}$	$V_{DD} = 3.3\text{V}$ , Bypass Mode.	1		400	MHz	
	$F_{ipll}$	$V_{DD} = 3.3\text{V}$ , 100MHz PLL Mode.	98.5	100.00	102.5	MHz	
	$F_{ipll}$	$V_{DD} = 3.3\text{V}$ , 133.33MHz PLL Mode.	132	133.33	135	MHz	6
ppm Error Contribution	ppm	ppm error contributed to input clock.	0			ppm	
Pin Inductance	$L_{pin}$				7	nH	1
Capacitance	$C_{IN}$	Logic inputs, except DIF_IN.	1.5		5	pF	1
	$C_{INDIF\_IN}$	DIF_IN differential clock inputs.	1.5		2.7	pF	1,4
	$C_{OUT}$	Output pin capacitance.			6	pF	1
Clk Stabilization	$T_{STAB}$	From $V_{DD}$ power-up and after input clock stabilization or deassertion of PD# to 1st clock.		1	1.8	ms	1,2
Input SS Modulation Frequency PCIe	$f_{MODINPCIe}$	Allowable frequency for PCIe applications (Triangular modulation).	30		33	kHz	
OE# Latency	$t_{LATO\#}$	DIF start after OE# assertion. DIF stop after OE# deassertion.	4	5	10	clocks	1,2,3
Tdrive_PD#	$t_{DRVPD}$	DIF output enable after PD# deassertion.		49	300	$\mu\text{s}$	1,3
Tfall	$t_F$	Fall time of control inputs.			5	ns	2
Trise	$t_R$	Rise time of control inputs.			5	ns	2

<sup>1</sup> Guaranteed by design and characterization, not 100% tested in production.

<sup>2</sup> Control input must be monotonic from 20% to 80% of input swing.

<sup>3</sup> Time from deassertion until outputs are > 200mV.

<sup>4</sup> DIF\_IN input.

<sup>5</sup> 9ZXL12x2 only.

<sup>6</sup> 9ZXL12x2 and 9ZXL08x2 only.

<sup>7</sup> Not all devices are available in this temperature range. See [Ordering Information](#) for details.

**Table 7. Current Consumption – 9ZXL12**

Parameter	Symbol	Conditions	Minimum	Typical	Maximum	Units	Notes
Operating Supply Current	I <sub>DDA</sub>	V <sub>DDA</sub> , PLL Mode at 100MHz.		38	46	mA	1
		V <sub>DDA</sub> , Fanout Buffer Mode at 100MHz.		4	5	mA	1
	I <sub>DD</sub>	All other V <sub>DD</sub> pins.		25	34	mA	
	I <sub>DDOIO</sub>	V <sub>DDIO</sub> for LP-HCSL outputs, if applicable.		83	107	mA	
Power Down Current	I <sub>DDAPD</sub>	V <sub>DDA</sub> , CKPWRGD_PD# = 0.		3	4	mA	1
	I <sub>DDPD</sub>	All other V <sub>DD</sub> pins, CKPWRGD_PD# = 0.		1	2	mA	

<sup>1</sup> Includes V<sub>DDR</sub>.

**Table 8. Current Consumption – 9ZXL08**

Parameter	Symbol	Conditions	Minimum	Typical	Maximum	Units	Notes
Operating Supply Current	I <sub>DDA</sub>	V <sub>DDA</sub> , PLL Mode at 100MHz.		37	45	mA	1
		V <sub>DDA</sub> , Fanout Buffer Mode at 100MHz.		4	5	mA	1
	I <sub>DD</sub>	All other V <sub>DD</sub> pins at 100MHz.		55	68	mA	
Power Down Current	I <sub>DDAPD</sub>	V <sub>DDA</sub> , CKPWRGD_PD# = 0.		3	4	mA	1
	I <sub>DDPD</sub>	All other V <sub>DD</sub> pins, CKPWRGD_PD# = 0.		1	2	mA	

<sup>1</sup> Includes V<sub>DDR</sub>.

**Table 9. Current Consumption – 9ZXL06**

Parameter	Symbol	Conditions	Minimum	Typical	Maximum	Units	Notes
Operating Supply Current	I <sub>DDA</sub>	V <sub>DDA</sub> , PLL Mode at 100MHz.		37	45	mA	1
		V <sub>DDA</sub> , Fanout Buffer Mode at 100MHz.		4	5	mA	1
	I <sub>DD</sub>	All other V <sub>DD</sub> pins at 100MHz.		41	50	mA	
Power Down Current	I <sub>DDAPD</sub>	V <sub>DDA</sub> , CKPWRGD_PD# = 0.		3	4	mA	1
	I <sub>DDPD</sub>	All other V <sub>DD</sub> pins, CKPWRGD_PD# = 0.		1	2	mA	

<sup>1</sup> Includes V<sub>DDR</sub>.

**Table 10. Skew and Differential Jitter Parameters**

$T_{AMB}$  = over the specified operating range. Supply voltages per normal operation conditions; see [Test Loads](#) for loading conditions.

Parameter	Symbol	Conditions	Minimum	Typical	Maximum	Units	Notes
CLK_IN, DIF[x:0]	$t_{SPO\_PLL}$	Input-to-output skew in PLL Mode at 100MHz, nominal temperature and voltage.	-100	-21.3	100	ps	1,2,4,5,7
CLK_IN, DIF[x:0]	$t_{PD\_BYP}$	Input-to-output skew in Bypass Mode at 100MHz, nominal temperature and voltage.	2	2.6	3	ns	1,2,3,5,7
CLK_IN, DIF[x:0]	$t_{DSPO\_PLL}$	Input-to-output skew variation in PLL Mode at 100MHz, across voltage and temperature.	-50	0.0	50	ps	1,2,3,5,7
CLK_IN, DIF[x:0]	$t_{DSPO\_BYP}$	Input-to-output skew variation in Bypass Mode at 100MHz, across voltage and temperature, $T_{AMB} = 0C$ to $+70^{\circ}C$ .	-250		250	ps	1,2,3,5,7
		Input-to-output skew variation in Bypass mode at 100MHz, across voltage and temperature, $T_{AMB} = -40^{\circ}C$ to $+85^{\circ}C$ .	-350		350	ps	1,2,3,5,7
CLK_IN, DIF[x:0]	$t_{DTE}$	Random differential tracking error between two 9ZX devices in Hi BW Mode.		3	5	ps (rms)	1,2,3,5,7
CLK_IN, DIF[x:0]	$t_{DSSTE}$	Random differential spread spectrum tracking error between two 9ZX devices in Hi BW Mode.		23	50	ps	1,2,3,5,7
DIF[x:0]	$t_{SKEW\_ALL}$	Output-to-output skew across all outputs, common to PLL and Bypass Mode, at 100MHz.			50	ps	1,2,3,7
PLL Jitter Peaking	$j_{peak-hibw}$	LOBW#_BYPASS_HIBW = 1.	0	1.3	2.5	dB	6,7
PLL Jitter Peaking	$j_{peak-lobw}$	LOBW#_BYPASS_HIBW = 0.	0	1.3	2	dB	6,7
PLL Bandwidth	$pll_{HIBW}$	LOBW#_BYPASS_HIBW = 1.	2	2.6	4	MHz	7,8
PLL Bandwidth	$pll_{LOBW}$	LOBW#_BYPASS_HIBW = 0.	0.7	1.0	1.4	MHz	7,8
Duty Cycle	$t_{DC}$	Measured differentially, PLL Mode.	45	50.3	55	%	1
Duty Cycle Distortion	$t_{DCD}$	Measured differentially, Bypass Mode at 100MHz.	-1	0	1	%	1,9
Jitter, Cycle to Cycle	$t_{jcy-cyc}$	PLL Mode.		14	50	ps	1,10
		Additive jitter in Bypass Mode.		0.1	5	ps	1,10

<sup>1</sup> Measured into fixed 2pF load cap. Input-to-output skew is measured at the first output edge following the corresponding input.

<sup>2</sup> Measured from differential cross-point to differential cross-point. This parameter can be tuned with external feedback path, if present.

<sup>3</sup> All Bypass Mode input-to-output specs refer to the timing between an input edge and the specific output edge created by it.

<sup>4</sup> This parameter is deterministic for a given device.

<sup>5</sup> Measured with scope averaging on to find mean value.

<sup>6</sup> Measured as maximum pass band gain. At frequencies within the loop BW, highest point of magnification is called PLL jitter peaking.

<sup>7</sup> Guaranteed by design and characterization, not 100% tested in production.

<sup>8</sup> Measured at 3db down or half power point.

<sup>9</sup> Duty cycle distortion is the difference in duty cycle between the output and the input clock when the device is operated in Bypass Mode.

<sup>10</sup> Measured from differential waveform.

**Table 11. LP-HCSL Outputs**

T<sub>AMB</sub> = over the specified operating range. Supply voltages per normal operation conditions; see [Test Loads](#) for loading conditions.

Parameter	Symbol	Conditions	Minimum	Typical	Maximum	Specification Limits	Units	Notes
Slew Rate	dV/dt	Scope averaging on.	2	2.9	4	1–4	V/ns	1,2,3
Slew Rate Matching	ΔdV/dt	Single-ended measurement.		7.1	20	20	%	1,4,7
Maximum Voltage	V <sub>max</sub>	Measurement on single-ended signal using absolute value (scope averaging off).	700	792	850	660–1150	mV	7,8
Minimum Voltage	V <sub>min</sub>		-150	-35	150	-300		7,8
Crossing Voltage (abs)	V <sub>cross_abs</sub>	Scope averaging off.	300	372	462	250–550	mV	1,5,7
Crossing Voltage (var)	Δ-V <sub>cross</sub>	Scope averaging off.		15	50	140	mV	1,6,7

<sup>1</sup> Guaranteed by design and characterization, not 100% tested in production.

<sup>2</sup> Measured from differential waveform.

<sup>3</sup> Slew rate is measured through the V<sub>swing</sub> voltage range centered around differential 0 V. This results in a ±150mV window around differential 0V.

<sup>4</sup> Matching applies to rising edge rate for Clock and falling edge rate for Clock#. It is measured using a ±75mV window centered on the average cross point where Clock rising meets Clock# falling. The median cross point is used to calculate the voltage thresholds the oscilloscope is to use for the edge rate calculations.

<sup>5</sup> V<sub>cross</sub> is defined as voltage where Clock = Clock# measured on a component test board and only applies to the differential rising edge (i.e. Clock rising and Clock# falling).

<sup>6</sup> The total variation of all V<sub>cross</sub> measurements in any particular system. Note that this is a subset of V<sub>cross\_min/max</sub> (V<sub>cross</sub> absolute) allowed. The intent is to limit V<sub>cross</sub> induced modulation by setting Δ-V<sub>cross</sub> to be smaller than V<sub>cross</sub> absolute.

<sup>7</sup> At default SMBus settings.

<sup>8</sup> Includes previously separate values of +300mV overshoot and -300mV of undershoot.

**Table 12. PCIe Phase Jitter Parameters**

T<sub>AMB</sub> = over the specified operating range. Supply voltages per normal operation conditions; see [Test Loads](#) for loading conditions.

Parameter	Symbol	Conditions	Minimum	Typical	Maximum	Limits	Units	Notes
PCIe Phase Jitter, Low Bandwidth ZDB Mode (Common Clocked Architecture)	t <sub>jphPCIeG1-CC</sub>	PCIe Gen 1 (2.5 GT/s)		2.6	6.8	86	ps (p-p)	1,2
	t <sub>jphPCIeG2-CC</sub>	PCIe Gen 2 Hi Band (5.0 GT/s)		0.09	0.16	3	ps (RMS)	1,2
		PCIe Gen 2 Lo Band (5.0 GT/s)		0.08	0.12	3.1	ps (RMS)	1,2
	t <sub>jphPCIeG3-CC</sub>	PCIe Gen 3 (8.0 GT/s)		0.05	0.07	1	ps (RMS)	1,2
	t <sub>jphPCIeG4-CC</sub>	PCIe Gen 4 (16.0 GT/s)		0.05	0.07	0.5	ps (RMS)	1,2,3,4
	t <sub>jphPCIeG5-CC</sub>	PCIe Gen 5 (32.0 GT/s)		0.018	0.022	0.15	ps (RMS)	1,2,3,5,7
PCIe Phase Jitter, Low Bandwidth ZDB Mode (SRIS Architecture)	t <sub>jphPCIeG1-SRIS</sub>	PCIe Gen 1 (2.5 GT/s)		8.71	8.73	N/A	ps (RMS)	1,2,6
	t <sub>jphPCIeG2-SRIS</sub>	PCIe Gen 2 (5.0 GT/s)		0.81	0.83		ps (RMS)	1,2,6
	t <sub>jphPCIeG3-SRIS</sub>	PCIe Gen 3 (8.0 GT/s)		0.329	0.335		ps (RMS)	1,2,6
	t <sub>jphPCIeG4-SRIS</sub>	PCIe Gen 4 (16.0 GT/s)		0.222	0.235		ps (RMS)	1,2,6
	t <sub>jphPCIeG5-SRIS</sub>	PCIe Gen 5 (32.0 GT/s)		0.084	0.091		ps (RMS)	1,2,6

**Table 12. PCIe Phase Jitter Parameters (Cont.)**

T<sub>AMB</sub> = over the specified operating range. Supply voltages per normal operation conditions; see [Test Loads](#) for loading conditions.

Parameter	Symbol	Conditions	Minimum	Typical	Maximum	Limits	Units	Notes
PCIe Phase Jitter, High Bandwidth ZDB Mode (Common Clocked Architecture)	t <sub>jphPCIeG1-CC</sub>	PCIe Gen 1 (2.5 GT/s)		5.4	6.9	86	ps (p-p)	1,2
	t <sub>jphPCIeG2-CC</sub>	PCIe Gen 2 Hi Band (5.0 GT/s)		0.19	0.25	3	ps (RMS)	1,2
		PCIe Gen 2 Lo Band (5.0 GT/s)		0.09	0.13	3.1	ps (RMS)	1,2
	t <sub>jphPCIeG3-CC</sub>	PCIe Gen 3 (8.0 GT/s)		0.10	0.13	1	ps (RMS)	1,2
	t <sub>jphPCIeG4-CC</sub>	PCIe Gen 4 (16.0 GT/s)		0.10	0.13	0.5	ps (RMS)	1,2,3,4
t <sub>jphPCIeG5-CC</sub>	PCIe Gen 5 (32.0 GT/s)		0.032	0.042	0.15	ps (RMS)	1,2,3,5,7	
PCIe Phase Jitter, High Bandwidth ZDB Mode (SRIS Architecture)	t <sub>jphPCIeG1-SRIS</sub>	PCIe Gen 1 (2.5 GT/s)		8.61	8.63	N/A	ps (RMS)	1,2,6
	t <sub>jphPCIeG2-SRIS</sub>	PCIe Gen 2 (5.0 GT/s)		0.88	0.96		ps (RMS)	1,2,6
	t <sub>jphPCIeG3-SRIS</sub>	PCIe Gen 3 (8.0 GT/s)		0.354	0.375		ps (RMS)	1,2,6
	t <sub>jphPCIeG4-SRIS</sub>	PCIe Gen 4 (16.0 GT/s)		0.271	0.305		ps (RMS)	1,2,6
	t <sub>jphPCIeG5-SRIS</sub>	PCIe Gen 5 (32.0 GT/s)		0.097	0.109		ps (RMS)	1,2,6

<sup>1</sup> The Refclk jitter is measured after applying the filter functions found in PCI Express Base Specification 5.0, Revision 1.0. See the [Test Loads](#) section of the data sheet for the exact measurement setup. The worst case results for each data rate are summarized in this table. Equipment noise is removed from all results.

<sup>2</sup> Jitter measurements shall be made with a capture of at least 100,000 clock cycles captured by a real-time oscilloscope (RTO) with a sample rate of 20 GS/s or greater. Broadband oscilloscope noise must be minimized in the measurement. The measured PP jitter is used (no extrapolation) for RTO measurements. Alternately, jitter measurements may be used with a Phase Noise Analyzer (PNA) extending (flat) and integrating and folding the frequency content up to an offset from the carrier frequency of at least 200MHz (at 300MHz absolute frequency) below the Nyquist frequency. For PNA measurements for the 2.5 GT/s data rate, the RMS jitter is converted to peak-to-peak jitter using a multiplication factor of 8.83. In the case where real-time oscilloscope and PNA measurements have both been done and produce different results, the RTO result must be used.

<sup>3</sup> SSC spurs from the fundamental and harmonics are removed up to a cutoff frequency of 2 MHz taking care to minimize removal of any non-SSC content.

<sup>4</sup> Note that 0.7ps RMS is to be used in channel simulations to account for additional noise in a real system.

<sup>5</sup> Note that 0.25ps RMS is to be used in channel simulations to account for additional noise in a real system.

<sup>6</sup> The PCI Express Base Specification 5.0, Revision 1.0 provides the filters necessary to calculate SRIS jitter values, however, it does not provide specification limits, hence the n/a in the Limit column. SRIS values are informative only. In general, a clock operating in an SRIS system must be twice as good as a clock operating in a Common Clock system. For RMS values, twice as good is equivalent to dividing the CC value by  $\sqrt{2}$ . An additional consideration is the value for which to divide by  $\sqrt{2}$ . The conservative approach is to divide the ref clock jitter limit, and the case can be made for dividing the channel simulation values by  $\sqrt{2}$ , if the ref clock is close to the Tx clock input. An example for Gen4 is as follows. A "rule-of-thumb" SRIS limit would be either  $0.5\text{ps RMS}/\sqrt{2} = 0.35\text{ps RMS}$  if the clock chip is far from the clock input, or  $0.7\text{ps RMS}/\sqrt{2} = 0.5\text{ps RMS}$  if the clock chip is near the clock input.

<sup>7</sup> This specification also applied to UPI data rates  $\geq 20\text{Gb/s}$ .



**Table 13. Additive PCIe Phase Jitter for Fanout Buffer Mode**

T<sub>AMB</sub> = over the specified operating range. Supply voltages per normal operation conditions; see [Test Loads](#) for loading conditions.

Parameter	Symbol	Conditions	Minimum	Typical	Maximum	Limits	Units	Notes
Additive PCIe Phase Jitter, Fanout Buffer Mode <sup>7</sup> (Common Clocked Architecture)	t <sub>jphPCIeG1-CC</sub>	PCIe Gen1 (2.5 GT/s)		1.3	1.9	86	ps (p-p)	1,2
	t <sub>jphPCIeG2-CC</sub>	PCIe Gen2 Hi Band (5.0 GT/s)		0.089	0.126	3	ps (RMS)	1,2
		PCIe Gen2 Lo Band (5.0 GT/s)		0.023	0.034	3.1	ps (RMS)	1,2
	t <sub>jphPCIeG3-CC</sub>	PCIe Gen3 (8.0 GT/s)		0.044	0.062	1	ps (RMS)	1,2
	t <sub>jphPCIeG4-CC</sub>	PCIe Gen4 (16.0 GT/s)		0.044	0.062	0.5	ps (RMS)	1,2,3,4
t <sub>jphPCIeG5-CC</sub>	PCIe Gen5 (32.0 GT/s)		0.017	0.024	0.15	ps (RMS)	1,2,3,5,8	
Additive PCIe Phase Jitter, Fanout Buffer Mode <sup>7</sup> (SRIS Architecture)	t <sub>jphPCIeG1-SRIS</sub>	PCIe Gen1 (2.5 GT/s)		0.127	0.181	N/A	ps (RMS)	1,2,6
	t <sub>jphPCIeG2-SRIS</sub>	PCIe Gen2 (5.0 GT/s)		0.112	0.159		ps (RMS)	1,2,6
	t <sub>jphPCIeG3-SRIS</sub>	PCIe Gen3 (8.0 GT/s)		0.029	0.042		ps (RMS)	1,2,6
	t <sub>jphPCIeG4-SRIS</sub>	PCIe Gen4 (16.0 GT/s)		0.031	0.043		ps (RMS)	1,2,6
	t <sub>jphPCIeG5-SRIS</sub>	PCIe Gen5 (32.0 GT/s)		0.027	0.038		ps (RMS)	1,2,6

<sup>1</sup> The Refclk jitter is measured after applying the filter functions found in PCI Express Base Specification 5.0, Revision 1.0. See the [Test Loads](#) section of the data sheet for the exact measurement setup. The total Ref Clk jitter limits for each data rate are listed for convenience. The worst case results for each data rate are summarized in this table. Equipment noise is removed from all results.

<sup>2</sup> Jitter measurements shall be made with a capture of at least 100,000 clock cycles captured by a real-time oscilloscope (RTO) with a sample rate of 20 GS/s or greater. Broadband oscilloscope noise must be minimized in the measurement. The measured PP jitter is used (no extrapolation) for RTO measurements. Alternately, jitter measurements may be used with a Phase Noise Analyzer (PNA) extending (flat) and integrating and folding the frequency content up to an offset from the carrier frequency of at least 200MHz (at 300MHz absolute frequency) below the Nyquist frequency. For PNA measurements for the 2.5 GT/s data rate, the RMS jitter is converted to peak-to-peak jitter using a multiplication factor of 8.83. In the case where real-time oscilloscope and PNA measurements have both been done and produce different results, the RTO result must be used.

<sup>3</sup> SSC spurs from the fundamental and harmonics are removed up to a cutoff frequency of 2 MHz taking care to minimize removal of any non-SSC content.

<sup>4</sup> Note that 0.7ps RMS is to be used in channel simulations to account for additional noise in a real system.

<sup>5</sup> Note that 0.25ps RMS is to be used in channel simulations to account for additional noise in a real system.

<sup>6</sup> The PCI Express Base Specification 5.0, Revision 1.0 provides the filters necessary to calculate SRIS jitter values, however, it does not provide specification limits, hence the n/a in the Limit column. SRIS values are informative only. In general, a clock operating in an SRIS system must be twice as good as a clock operating in a Common Clock system. For RMS values, twice as good is equivalent to dividing the CC value by  $\sqrt{2}$ . An additional consideration is the value for which to divide by  $\sqrt{2}$ . The conservative approach is to divide the ref clock jitter limit, and the case can be made for dividing the channel simulation values by  $\sqrt{2}$ , if the ref clock is close to the Tx clock input. An example for Gen4 is as follows. A "rule-of-thumb" SRIS limit would be either  $0.5\text{ps RMS}/\sqrt{2} = 0.35\text{ps RMS}$  if the clock chip is far from the clock input, or  $0.7\text{ps RMS}/\sqrt{2} = 0.5\text{ps RMS}$  if the clock chip is near the clock input.

<sup>7</sup> Additive jitter for RMS values is calculated by solving for "b" where  $b = \sqrt{c^2 - a^2}$  and "a" is rms input jitter and "c" is rms output jitter.

<sup>8</sup> This specification also applied to UPI data rates  $\geq 20\text{Gb/s}$ .

**Table 14. Filtered Phase Jitter Parameters – QPI/UPI, IF-UPI and DB2000Q**

T<sub>AMB</sub> = over the specified operating range. Supply voltages per normal operation conditions; see [Test Loads](#) for loading conditions.

Parameter	Symbol	Conditions	Minimum	Typical	Maximum	Specification Limits	Units	Notes
Phase Jitter, ZDB Mode	t <sub>jphQPI_UPI</sub>	QPI and UPI (100MHz or 133MHz, 4.8Gb/s, 6.4Gb/s 12UI)		0.16	0.37	0.5	ps (RMS)	1,2
		QPI and UPI (100MHz, 8.0Gb/s, 12UI)		0.10	0.15	0.3	ps (RMS)	1,2
		QPI and UPI (100MHz, ≤11.4Gb/s, 12UI)		0.08	0.12	0.2	ps (RMS)	1,2
Additive Phase Jitter, Fanout Mode	t <sub>jphQPI_UPI</sub>	QPI and UPI (100MHz or 133MHz, 4.8Gb/s, 6.4Gb/s 12UI)		0.03	0.05	N/A	ps (RMS)	1,2,3
		QPI and UPI (100MHz, 8.0Gb/s, 12UI)		0.03	0.05		ps (RMS)	1,2,3
		QPI and UPI (100MHz, ≤11.4Gb/s, 12UI)		0.02	0.04		ps (RMS)	1,2,3
	t <sub>jphIF-UPI</sub>	IF-UPI, Lo-BW ZDB Mode		0.10	0.13	1	ps (RMS)	1,4,5
		IF-UPI, Hi-BW ZDB Mode		0.17	0.20	1	ps (RMS)	1,4,5
		IF-UPI, Fanout Mode		0.06	0.07	1	ps (RMS)	1,4
	t <sub>jphDB2000Q</sub>	DB2000Q, Fanout Mode		28	39	80	fs (RMS)	1,4,5

<sup>1</sup> Applies to all differential outputs, guaranteed by design and characterization. See [Test Loads](#) for measurement setup details.

<sup>2</sup> Calculated from Intel-supplied clock jitter tool.

<sup>3</sup> For RMS values, additive jitter is calculated by solving for “b” where  $b = \sqrt{c^2 - a^2}$ , “a” is rms input jitter and “c” is rms total jitter.

<sup>4</sup> Calculated from phase noise analyzer with Intel-specified brick-wall filter applied. This is an additive jitter specification regardless of buffer operating mode.

<sup>5</sup> The IF-UPI specification is an additive specification, regardless of the buffer operating mode. The enhanced 9ZXL devices meet this specification in all operating modes.

**Table 15. Phase Jitter Parameters – 12kHz to 20MHz**

T<sub>AMB</sub> = over the specified operating range. Supply voltages per normal operation conditions; see [Test Loads](#) for loading conditions.

Parameter	Symbol	Conditions	Minimum	Typical	Maximum	Specification Limits	Units	Notes
12kHz–20MHz Additive Phase Jitter, Fanout Buffer Mode	t <sub>jph12k-20MFOB</sub>	Fanout Buffer Mode, SSC OFF, 100MHz		98	125	N/A	fs (RMS)	1,2,3

<sup>1</sup> Applies to all differential outputs, guaranteed by design and characterization. See [Test Loads](#) for measurement setup details.

<sup>2</sup> 12kHz to 20MHz brick wall filter.

<sup>3</sup> For RMS values, additive jitter is calculated by solving for “b” where  $b = \sqrt{c^2 - a^2}$ , “a” is rms input jitter and “c” is rms total jitter.

## Power Management

**Table 16. Power Management**

CKPWRGD_PD#	DIF_IN	SMBus EN bit	OE[x]# Pin	DIF[x]	PLL State (in ZDB Mode)
0	X	X	X	Low/Low	OFF
1	Running	0	0	Low/Low	ON
		0	1	Low/Low	ON
		1	0	Running	ON
		1	1	Low/Low	ON

**Table 17. Frequency Selection (PLL Mode)**

100M_133M#	DIF_IN MHz	DIF[x]
1	100.00	DIF_IN
0	133.33	DIF_IN

Note: 9ZXL12xx and 9ZXL08xx only. 9ZXL06xx is 100MHz only.

**Table 18. PLL Operating Mode**

HiBW_BypM_LoBW#	Mode	PLL
Low	PLL Lo BW	Running
Mid	Bypass	Off
High	PLL Hi BW	Running

Note: See SMBus Byte 0, bits 7 and 6 for additional information.

## Test Loads

**Figure 5. Test Load for AC/DC Measurements**

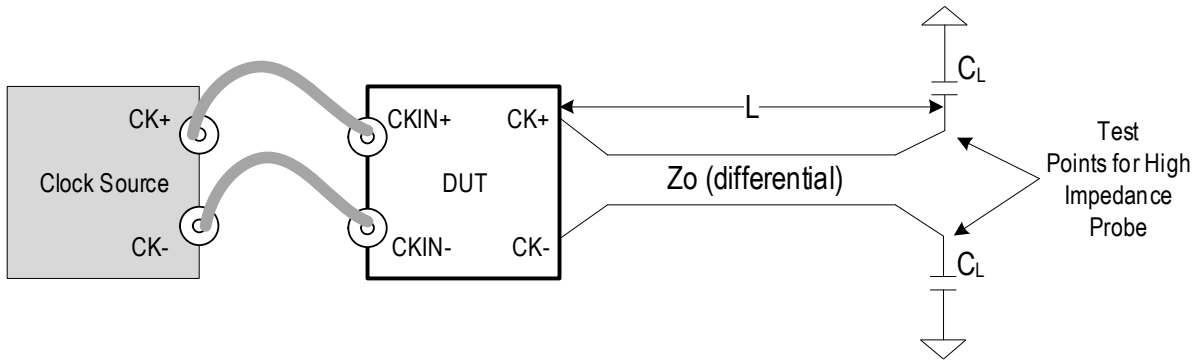

**Table 19. Parameters for AC/DC Measurements**

Clock Source	Device Under Test (DUT)	Rs ( $\Omega$ )	Differential Zo ( $\Omega$ )	L (cm)	CL (pF)	Parameters Measured
SMA100B	9ZXLxx3x	27 External	85	25.4	2	AC/DC parameters
SMA100B	9ZXLxx5x	Internal	85	25.4	2	

**Figure 6. Test Load for Phase Jitter Measurements using Phase Noise Analyzer**

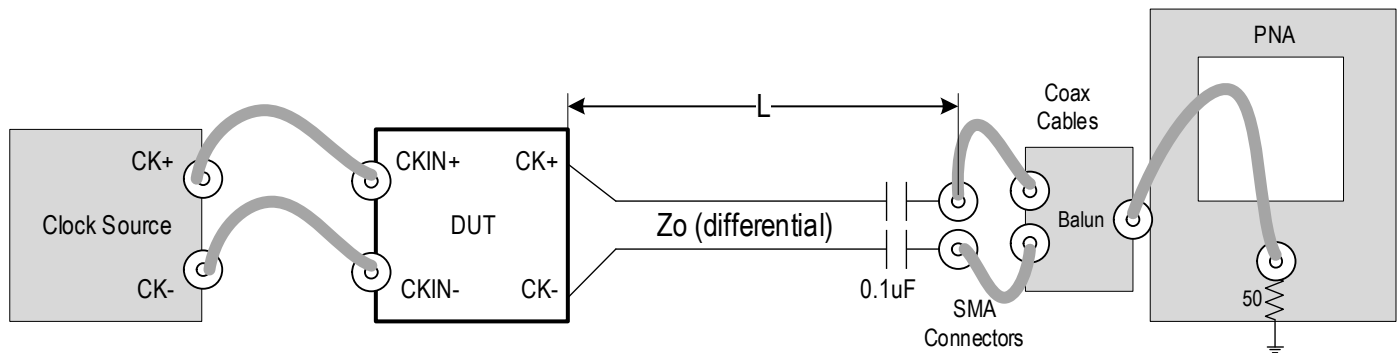

**Table 20. Parameters for Phase Jitter Measurements using Phase Noise Analyzer**

Clock Source	Device Under Test (DUT)	Rs ( $\Omega$ )	Differential Zo ( $\Omega$ )	L (cm)	CL (pF)	Notes	Parameters Measured
SMA100B	9ZXLxx3x	27 External	85	25.4	N/A	Fanout Mode	PCIe, IF-UPI, DB2000Q
9FGV1006	9ZXLxx3x	27 External	85	25.4		ZDB Mode	
SMA100B	9ZXLxx5x	Internal	85	25.4		Fanout Mode	
9FGV1006	9ZXLxx5x	Internal	85	25.4		ZDB Mode	

**Figure 7. Test Load for Phase Jitter Measurements using Oscilloscope**

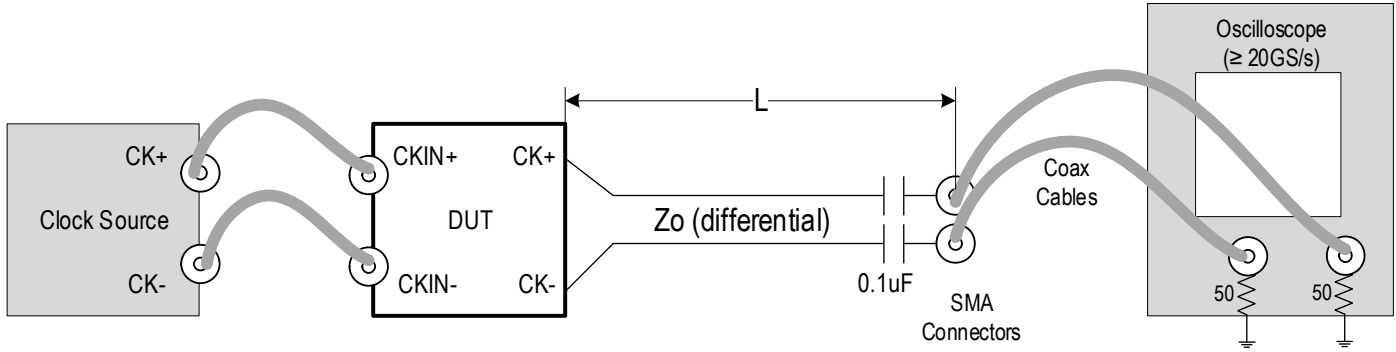

**Table 21. Parameters for Phase Jitter Measurements using Oscilloscope**

Clock Source	Device Under Test (DUT)	Rs (Ω)	Differential Zo (Ω)	L (cm)	CL (pF)	Notes	Parameters Measured
SMA100B	9ZXLxx3x	27 External	85	25.4	N/A	Fanout Mode	QPI/UPI
9FGV1006	9ZXLxx3x	27 External	85	25.4		ZDB Mode	
SMA100B	9ZXLxx5x	Internal	85	25.4		Fanout Mode	
9FGV1006	9ZXLxx5x	Internal	85	25.4		ZDB Mode	

## General SMBus Serial Interface Information

### How to Write

- Controller (host) sends a start bit
- Controller (host) sends the write address
- Renesas clock will **acknowledge**
- Controller (host) sends the beginning byte location = N
- Renesas clock will **acknowledge**
- Controller (host) sends the byte count = X
- Renesas clock will **acknowledge**
- Controller (host) starts sending Byte N through Byte N+X-1
- Renesas clock will **acknowledge** each byte **one at a time**
- Controller (host) sends a stop bit

Index Block Write Operation		
Controller (Host)		Renesas (Slave/Receiver)
T	starT bit	
Slave Address		
WR	WRite	
Beginning Byte = N		ACK
		ACK
Data Byte Count = X		ACK
Beginning Byte N		ACK
O	X Byte	O
O		O
O		O
Byte N + X - 1		ACK
P	stoP bit	

### How to Read

- Controller (host) will send a start bit
- Controller (host) sends the write address
- Renesas clock will **acknowledge**
- Controller (host) sends the beginning byte location = N
- Renesas clock will **acknowledge**
- Controller (host) will send a separate start bit
- Controller (host) sends the read address
- Renesas clock will **acknowledge**
- Renesas clock will send the data byte count = X
- Renesas clock sends Byte N+X-1
- Renesas clock sends **Byte 0 through Byte X (if X<sub>(H)</sub> was written to Byte 8)**
- Controller (host) will need to acknowledge each byte
- Controller (host) will send a not acknowledge bit
- Controller (host) will send a stop bit

Index Block Read Operation		
Controller (Host)		Renesas
T	starT bit	
Slave Address		
WR	WRite	
Beginning Byte = N		ACK
		ACK
RT	Repeat starT	
Slave Address		
RD	ReaD	
		ACK
		Data Byte Count=X
ACK		Beginning Byte N
ACK		O
O		O
O		O
O		
		Byte N + X - 1
N	Not acknowledge	
P	stoP bit	

**Table 22. SMBus Addressing**

Pin		SMBus Address		
SADR1_tri	SADR0_tri	9ZXL12x2 9ZXL0853	9ZXL08x2	9ZXL06x2
0	0	D8	D8	D8
0	M	DA	—	—
0	1	DE	—	—
M	0	C2	—	—
M	M	C4	—	—
M	1	C6	—	—
1	0	CA	—	—
1	M	CC	—	—
1	1	CE	—	—

**Note:** 9ZXL08x2 and 9ZXL06x2 do not have SMBus address select pins. Their address is D8.

**Table 23. Byte 0: PLL Mode and Frequency Select Register**

Byte 0	Bit7	Bit6	Bit5	Bit4	Bit3	Bit2	Bit1	Bit0
<b>Control Function</b>	PLL Operating Mode Readback 1	PLL Operating Mode Readback 0	Reserved	Reserved	Enable software control of PLL BW	PLL Operating Mode 1	PLL Operating Mode 0	Frequency Select Readback
<b>Type</b>	R	R			RW	RW	RW	R
<b>0</b>	00 = Low BW ZDB Mode	01 = Bypass (Fanout Buffer)			HW Latch	00 = Low BW ZDB Mode	01 = Bypass (Fanout Buffer)	133MHz
<b>1</b>	10 = Reserved	11 = High BW ZDB Mode			SMBus Control	10 = Reserved	11 = High BW ZDB Mode	100MHz
<b>Name</b>	PLL Rdbk[1]	PLL Rdbk[0]			PLL_SW_EN	PLL Mode[1]	PLL Mode[0]	100M_133M#
<b>Default</b>	Latch	Latch	0	0	0	1	1	Latch

**Note:** Setting bit 3 to '1' allows the user to override the latch value from pin 5 via use of bits 2 and 1. A warm system reset is required if the user changes these bits. Bit 0 defaults to 1 on the 9ZXL06x2 devices.

**Table 24. Byte 1: Output Control Register 1**

Byte 1	Bit7	Bit6	Bit5	Bit4	Bit3	Bit2	Bit1	Bit0
Control Function	Output Enable							
Type	RW							
0	Low/Low							
1	OE# Pin Control							
9ZXL12xx Name	DIF7_en	DIF6_en	DIF5_en	DIF4_en	DIF3_en	DIF2_en	DIF1_en	DIF0_en
9ZXL12xx Default	1	1	1	1	1	1	1	1
9ZXL08xx Name	DIF5_en	DIF4_en	DIF3_en	DIF2_en	Reserved	DIF1_en	DIF0_en	Reserved
9ZXL08xx Default	1	1	1	1	0	1	1	0
9ZXL06xx Name	Reserved	DIF3_en	DIF2_en	Reserved	Reserved	DIF1_en	DIF0_en	Reserved
9ZXL06xx Default	0	1	1	0	0	1	1	0

**Table 25. Byte 2: Output Control Register 2**

Byte 2	Bit7	Bit6	Bit5	Bit4	Bit3	Bit2	Bit1	Bit0
Control Function	Output_enable							
Type	RW							
0	Low/Low							
1	OE# Pin Control							
9ZXL12xx Name	Reserved	Reserved	Reserved	Reserved	DIF11_en	DIF10_en	DIF9_en	DIF8_en
9ZXL12xx Default	0	0	0	0	1	1	1	1
9ZXL08xx Name	Reserved	Reserved	Reserved	Reserved	Reserved	DIF7_en	Reserved	DIF6_en
9ZXL08xx Default	0	0	0	0	0	1	0	1
9ZXL06xx Name	Reserved	Reserved	Reserved	Reserved	Reserved	DIF5_en	DIF4_en	Reserved
9ZXL06xx Default	0	0	0	0	0	1	1	0

Bytes 3 and 4 are Reserved



**Table 26. Byte 5: Revision and Vendor ID Register**

Byte 5	Bit7	Bit6	Bit5	Bit4	Bit3	Bit2	Bit1	Bit0
Control Function	Revision ID				Vendor ID			
Type	R	R	R	R	R	R	R	R
0	E rev = 0010				IDT/Renesas = 0001			
1								
Name	RID3	RID2	RID1	RID0	VID3	VID2	VID1	VID0
Default	0	1	0	0	0	0	0	1

**Table 27. Byte 6: Device ID Register**

Byte 6	Bit7	Bit6	Bit5	Bit4	Bit3	Bit2	Bit1	Bit0
Control Function	N/A							
Type	R	R	R	R	R	R	R	R
0	Device ID							
1								
Name	DevID 7	DevID 6	DevID 5	DevID 4	DevID 3	DevID 2	DevID 1	DevID 0
9ZXL1232E	0hE8							
9ZXL1252E	0hF8							
9ZXL0832E	0hE6							
9ZXL0852E	0hF6							
9ZXL0853E								
9ZXL0632E	0hE4							
9ZXL0652E	0hF4							

**Table 28. Byte 7: Byte Count Register**

Byte 7	Bit7	Bit6	Bit5	Bit4	Bit3	Bit2	Bit1	Bit0
Control Function	Reserved	Reserved	Reserved	Writing to this register configures how many bytes will be read back on a block read.				
Type				RW	RW	RW	RW	RW
0				Default value is 8.				
1								
Name				BC4	BC3	BC2	BC1	BC0
Default	0	0	0	0	1	0	0	0

## Package Outline Drawings

The package outline drawings are appended at the end of this document and are accessible from the link below. The package information is the most current data available.

### 9ZXL06x2E:

[www.idt.com/document/psc/ndndg40-package-outline-50-x-50-mm-bodyepad-350mm-sq-040-mm-pitch-qfn](http://www.idt.com/document/psc/ndndg40-package-outline-50-x-50-mm-bodyepad-350mm-sq-040-mm-pitch-qfn)

### 9ZXL08xxE:

[www.idt.com/document/psc/48-vfqfn-package-outline-drawing-60-x-60-x-090-mm-body-epad-42-x-42-mm-040mm-pitch-ndg48p2](http://www.idt.com/document/psc/48-vfqfn-package-outline-drawing-60-x-60-x-090-mm-body-epad-42-x-42-mm-040mm-pitch-ndg48p2)

### 9ZXL12x2E:

[www.idt.com/document/psc/64-vfqfn-package-outline-drawing-90-x-90-x-09-mm-body-05mm-pitch-epad-615-x-615-mm-nlg64p2](http://www.idt.com/document/psc/64-vfqfn-package-outline-drawing-90-x-90-x-09-mm-body-05mm-pitch-epad-615-x-615-mm-nlg64p2)

## Marking Diagrams

### 9ZXL06x2E

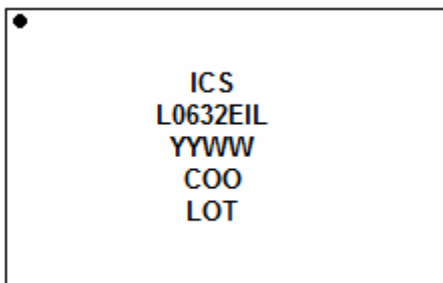

- Lines 1 and 2: truncated part number
- Line 3: “YYWW” is the last two digits of the year and the work week the part was assembled.
- Line 4: “COO” denotes country of origin.
- Line 5: “LOT” denotes the lot number.

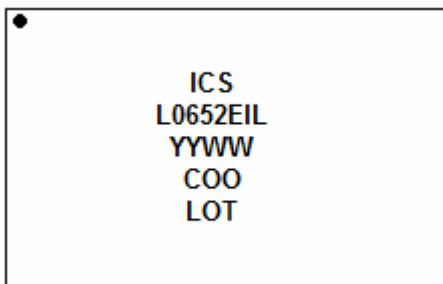

**9ZXL08xxE**

•  
 ICS  
 XL0832EIL  
 YYWW  
 COO  
 LOT

- Lines 1 and 2: truncated part number
- Line 3: "YYWW" is the last two digits of the year and the work week the part was assembled.
- Line 4: "COO" denotes country of origin.
- Line 5: "LOT" denotes the lot number.

•  
 ICS  
 XL0852EIL  
 YYWW  
 COO  
 LOT

•  
 ICS  
 XL0853EIL  
 YYWW  
 COO  
 LOT

**9ZXL12x2E**

•  
 ICS  
 9ZXL1232EIL  
 LOT  
 COO YYWW

- Lines 1 and 2: truncated part number
- Line 3: "LOT" denotes the lot number.
- Line 4: "COO" denotes country of origin; "YYWW" is the last two digits of the year and the work week the part was assembled.

•  
 ICS  
 9ZXL1252EIL  
 LOT  
 COO YYWW

## Ordering Information

**Table 29. Ordering Information**

Number of Clock Outputs	Output Impedance	Orderable Part Number	Temperature Range	Package	Part Number Suffix and Shipping Method
6	33Ω	9ZXL0632EKILF	-40° to +85°C	5 × 5 × 0.4 mm 40-VFQFPN	None = Trays "T" = Tape and Reel, Pin 1 Orientation: EIA-481C (see <a href="#">Table 30</a> for more details)
		9ZXL0632EKILFT			
	85Ω	9ZXL0652EKILF			
		9ZXL0652EKILFT			
8	33Ω	9ZXL0832EKILF	-40° to +85°C	6 × 6 × 0.4 mm 48-VFQFPN	
		9ZXL0832EKILFT			
	85Ω	9ZXL0852EKILF			
		9ZXL0852EKILFT			
	85Ω	9ZXL0853EKILF			
		9ZXL0853EKILFT			
12	33Ω	9ZXL1232EKILF	-40° to +85°C	9 × 9 × 0.5 mm 64-VFQFPN	
		9ZXL1232EKILFT			
	85Ω	9ZXL1252EKILF			
		9ZXL1252EKILFT			

"E" is the device revision designator (will not correlate with the datasheet revision).

"LF" denotes Pb-free configuration, RoHS compliant.

**Table 30. Pin 1 Orientation in Tape and Reel Packaging**

Part Number Suffix	Pin 1 Orientation	Illustration
T	Quadrant 1 (EIA-481-C)	

## Revision History

Revision Date	Description of Change
August 25, 2020	Updated PCIe Gen5 CC, DB2000Q, and QPI/UPI specifications in Key Specifications section on front page.
May 21, 2020	Initial release.

## IMPORTANT NOTICE AND DISCLAIMER

RENESAS ELECTRONICS CORPORATION AND ITS SUBSIDIARIES (“RENESAS”) PROVIDES TECHNICAL SPECIFICATIONS AND RELIABILITY DATA (INCLUDING DATASHEETS), DESIGN RESOURCES (INCLUDING REFERENCE DESIGNS), APPLICATION OR OTHER DESIGN ADVICE, WEB TOOLS, SAFETY INFORMATION, AND OTHER RESOURCES “AS IS” AND WITH ALL FAULTS, AND DISCLAIMS ALL WARRANTIES, EXPRESS OR IMPLIED, INCLUDING, WITHOUT LIMITATION, ANY IMPLIED WARRANTIES OF MERCHANTABILITY, FITNESS FOR A PARTICULAR PURPOSE, OR NON-INFRINGEMENT OF THIRD PARTY INTELLECTUAL PROPERTY RIGHTS.

These resources are intended for developers skilled in the art designing with Renesas products. You are solely responsible for (1) selecting the appropriate products for your application, (2) designing, validating, and testing your application, and (3) ensuring your application meets applicable standards, and any other safety, security, or other requirements. These resources are subject to change without notice. Renesas grants you permission to use these resources only for development of an application that uses Renesas products. Other reproduction or use of these resources is strictly prohibited. No license is granted to any other Renesas intellectual property or to any third party intellectual property. Renesas disclaims responsibility for, and you will fully indemnify Renesas and its representatives against, any claims, damages, costs, losses, or liabilities arising out of your use of these resources. Renesas' products are provided only subject to Renesas' Terms and Conditions of Sale or other applicable terms agreed to in writing. No use of any Renesas resources expands or otherwise alters any applicable warranties or warranty disclaimers for these products.

(Rev.1.0 Mar 2020)

### Corporate Headquarters

TOYOSU FORESIA, 3-2-24 Toyosu,  
Koto-ku, Tokyo 135-0061, Japan  
[www.renesas.com](http://www.renesas.com)

### Contact Information

For further information on a product, technology, the most up-to-date version of a document, or your nearest sales office, please visit:  
[www.renesas.com/contact/](http://www.renesas.com/contact/)

### Trademarks

Renesas and the Renesas logo are trademarks of Renesas Electronics Corporation. All trademarks and registered trademarks are the property of their respective owners.

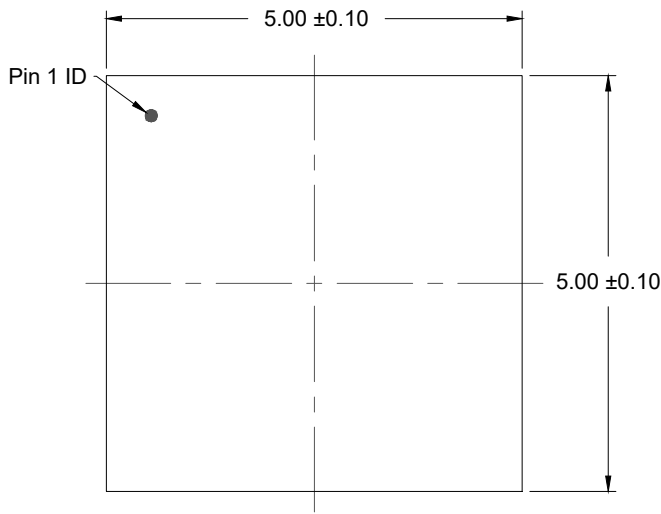

TOP VIEW

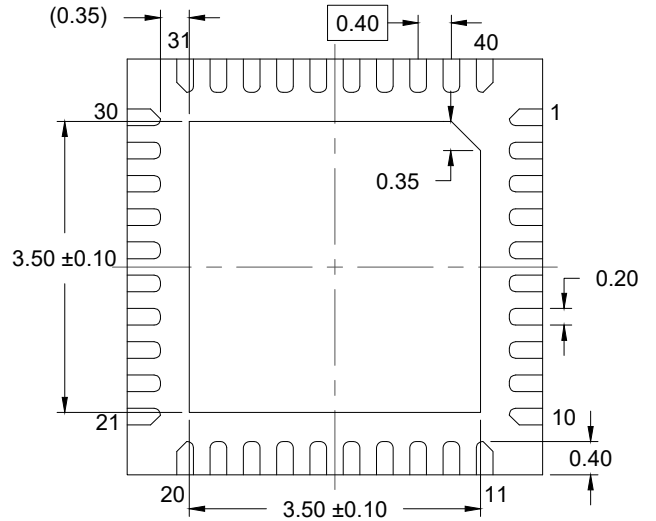

BOTTOM VIEW

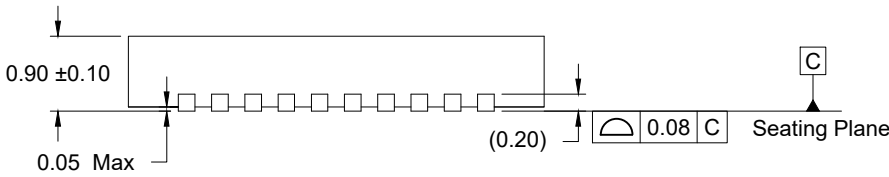

SIDE VIEW

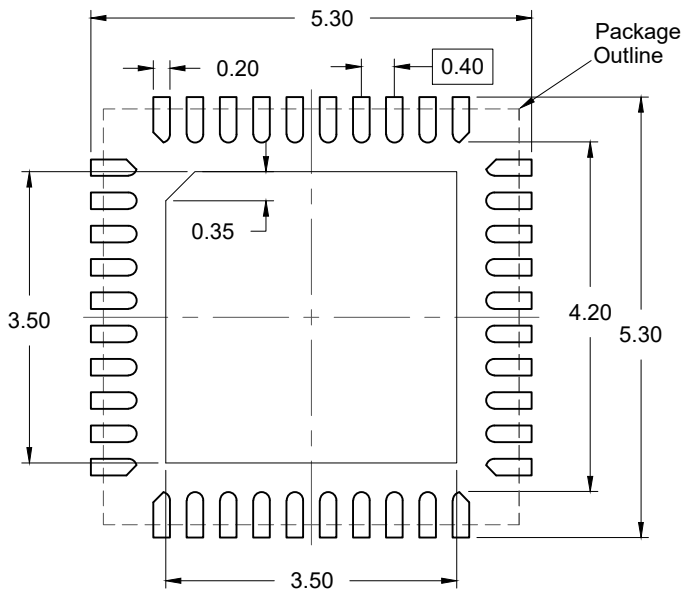

RECOMMENDED LAND PATTERN  
(PCB Top View, NSMD Design)

**NOTES:**

1. JEDEC compatible.
2. All dimensions are in mm and angles are in degrees.
3. Use  $\pm 0.05$  mm for the non-toleranced dimensions.
4. Numbers in ( ) are for references only.

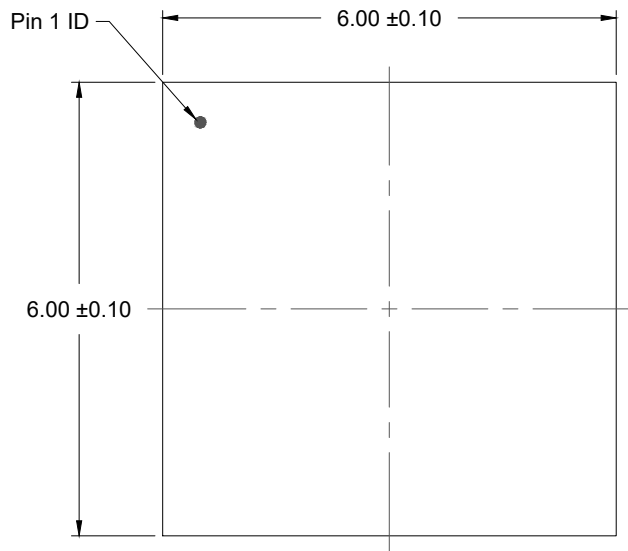

TOP VIEW

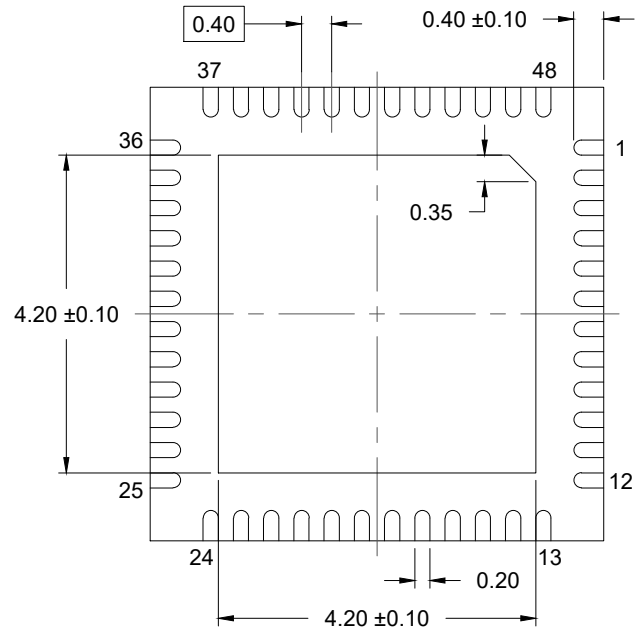

BOTTOM VIEW

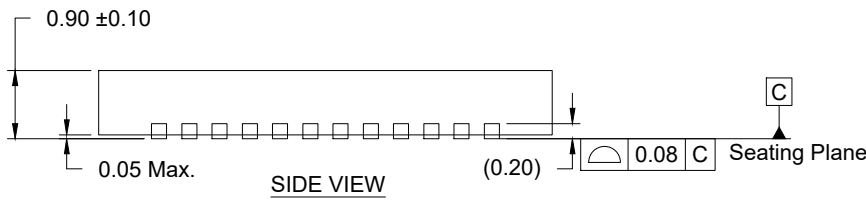

SIDE VIEW

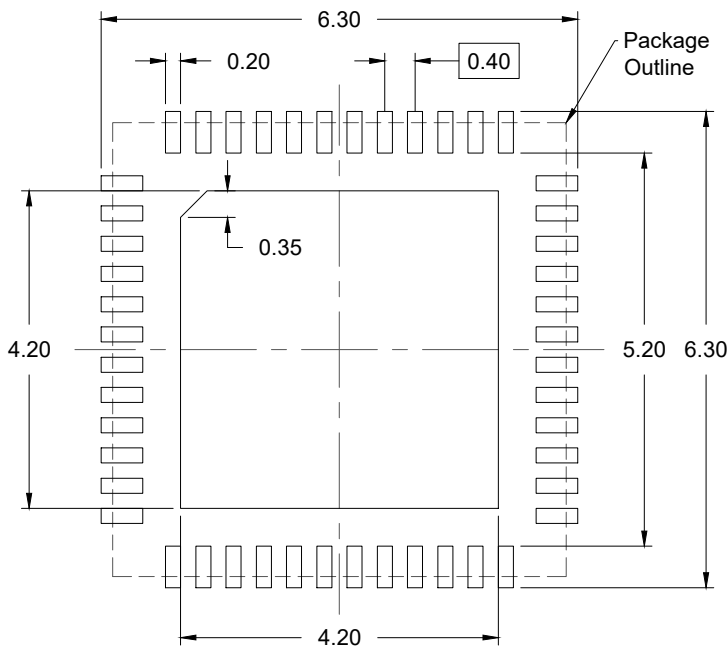

RECOMMENDED LAND PATTERN  
(PCB Top View, NSMD Design)

NOTES:

1. JEDEC compatible.
2. All dimensions are in mm and angles are in degrees.
3. Use  $\pm 0.05$  mm for the non-toleranced dimensions.
4. Numbers in ( ) are for references only.



