

# 9QXL2001C

20-Output Enhanced DB2000QL

The 9QXL2001C is an enhanced-performance 9QXL2001B with ultra-low-additive phase jitter for PCIe Gen5, Gen6 and UPI applications. The 9QXL2001C also reduces propagation delay by approximately 50% with respect to the 9QXL2001B.

## PCIe Clocking Architectures

- Common Clocked (CC)
- Independent Reference (IR) – SRNS, SRIS

## Applications

- Servers, Storage, Networking, Accelerators
- Key Specifications
- Output-to-output skew: < 50ps
- PCIe Gen5 additive phase jitter: 6fs RMS
- PCIe Gen6 additive phase jitter: 4fs RMS
- DB2000Q additive phase jitter: 10fs RMS
- 12kHz–20MHz additive jitter: 23fs RMS at 156.25MHz
- Propagation delay: 1.4ns typical

## Features

- 8 OE# pins provide hardware control of 8 outputs
- SMBus allows software control of each output
- 25MHz Side-Band Interface allows real-time control of all 20 outputs
- Outputs remain Low/Low when powered up with floating input clock
- Power Down Tolerant (PDT) inputs
- 85Ω Low-Power HCSL (LP-HCSL) outputs:
- Eliminate 80 resistors, saving 130mm<sup>2</sup> of area
- Power consumption reduced by 50%
- 9 selectable SMBus addresses
- Spread spectrum compatible
- 6 × 6 mm dual-row 80-GQFN
- -40° to +105°C, 3.3V ±10% operation

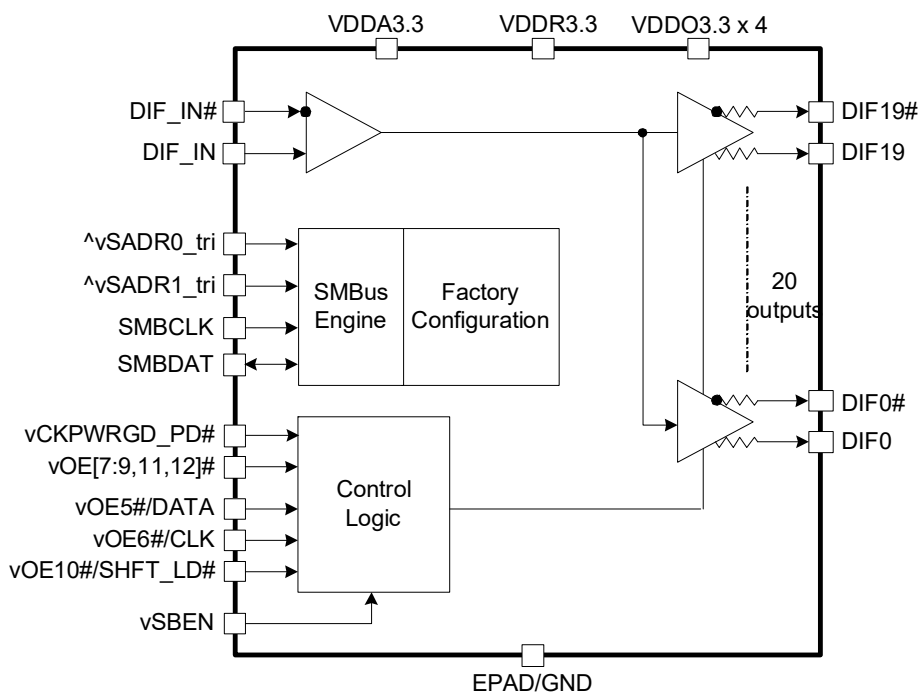

Figure 1. Block Diagram

## Contents

<b>1. Pin Information</b>	<b>3</b>
1.1 Signal Types	3
1.2 Pin Assignments	4
1.3 Pin Descriptions	4
<b>2. Specifications</b>	<b>8</b>
2.1 Absolute Maximum Ratings	8
2.2 Thermal Specifications	8
2.3 Electrical Specifications	8
<b>3. Output Control</b>	<b>14</b>
<b>4. Power Management</b>	<b>14</b>
<b>5. Output Enable Control on 9QXL2001C (DB2000QL)</b>	<b>15</b>
5.1 Traditional Method	15
5.2 Side-Band Interface	15
<b>6. Test Loads</b>	<b>17</b>
6.1 Alternate Terminations	17
<b>7. General SMBus Serial Interface Information</b>	<b>18</b>
7.1 How to Write	18
7.2 How to Read	18
7.3 SMBus Addressing	19
<b>8. Package Outline Drawings</b>	<b>24</b>
<b>9. Marking Diagram</b>	<b>24</b>
<b>10. Ordering Information</b>	<b>24</b>
<b>11. Revision History</b>	<b>25</b>

# 1. Pin Information

## 1.1 Signal Types

Table 1. Signal Types

Term	Description
I	Input
O	Input
OD	Open Drain Output
I/O	Bi-Directional
PD	Pull-down
PU	Pull-up
Z	Tristate
D	Driven
X	Don't care
SE	Single ended
DIF	Differential
PWR	3.3 V power
GND	Ground
PDT	Power Down Tolerant: These signals must tolerate being driven when the device is powered down.

*Note:* Some pins have both internal pull-up and pull-down resistors which bias the pins to VDD/2.

## 1.2 Pin Assignments

	1	2	3	4	5	6	7	8	9	10	11	12	
A	DIF17	DIF16#	DIF16	DIF15#	DIF15	DIF14#	DIF14	DIF13#	DIF13	DIF12#	DIF12	DIF11#	A
B	DIF17#	VDDO3.3	NC	<sup>^</sup> vSADR0_t ri	NC	VDDA3.3	NC	<sup>^</sup> vSADR1_t ri	NC	vOE12#	VDDO3.3	DIF11	B
C	DIF18	NC	<div style="border: 1px solid black; padding: 10px; text-align: center;"> <p>9QXL2001 6 x 6 mm, x 0.5mm pitch 80-GQFN Package Top View EPAD is GND</p> </div>								vOE11#	DIF10#	C
D	DIF18#	NC									NC	DIF10	D
E	DIF19	vSBEN									vOE10#/SH FT_LD#	vOE9#	E
F	DIF19#	NC									NC	DIF9#	F
G	DIF_IN	NC									NC	DIF9	G
H	DIF_IN#	VDDR3.3									vOE8#	DIF8#	H
J	DIF0	NC									NC	DIF8	J
K	DIF0#	NC									vOE7#	DIF7#	K
L	DIF1	VDDO3.3	NC	SMBDAT	SMBCLK	NC	NC	vOE5#/DAT A	NC	vOE6#/CLK	VDDO3.3	DIF7	L
M	DIF1#	DIF2	DIF2#	DIF3	DIF3#	vCKPW RG D_PD#	DIF4	DIF4#	DIF5	DIF5#	DIF6	DIF6#	M
	1	2	3	4	5	6	7	8	9	10	11	12	

*Note:* Pins with a <sup>^</sup> prefix have an internal pull-up resistor.  
Pins with a v prefix have an internal pull-down resistor.  
Pins with a <sup>^</sup>v prefix have an internal pull-up/down resistor biasing network.

Figure 2. Pin Assignments – Top View

## 1.3 Pin Descriptions

Table 2. Pin Descriptions

Number	Name	Type	Description
A 1	DIF17	O, DIF	Differential true clock output.
A 2	DIF16#	O, DIF	Differential complementary clock output.
A 3	DIF16	O, DIF	Differential true clock output.
A 4	DIF15#	O, DIF	Differential complementary clock output.

Table 2. Pin Descriptions (Cont.)

Number		Name	Type	Description
A	5	DIF15	O, DIF	Differential true clock output.
A	6	DIF14#	O, DIF	Differential complementary clock output.
A	7	DIF14	O, DIF	Differential true clock output.
A	8	DIF13#	O, DIF	Differential complementary clock output.
A	9	DIF13	O, DIF	Differential true clock output.
A	10	DIF12#	O, DIF	Differential complementary clock output.
A	11	DIF12	O, DIF	Differential true clock output.
A	12	DIF11#	O, DIF	Differential complementary clock output.
B	1	DIF17#	O, DIF	Differential complementary clock output.
B	2	VDDO3.3	PWR	Power supply for outputs. Nominally 3.3V.
B	3	NC	NC	No connection.
B	4	$\wedge$ vSADR0_tri	I, SE, PD, PU	SMBus address bit. This is a tri-level input that works in conjunction with other SADR pins, if present, to decode SMBus addresses. It has internal pull-up/down resistors to bias to $V_{DD}/2$ . See the <a href="#">SMBus Addressing</a> table.
B	5	NC	NC	No connection.
B	6	VDDA3.3	PWR	3.3V power for the PLL core.
B	7	NC	NC	No connection.
B	8	$\wedge$ vSADR1_tri	I, SE, PD, PU	SMBus address bit. This is a tri-level input that works in conjunction with other SADR pins, if present, to decode SMBus addresses. It has internal pull-up/down resistors to bias to $V_{DD}/2$ . See the <a href="#">SMBus Addressing</a> table.
B	9	NC	NC	No connection.
B	10	vOE12#	I, SE, PD, PDT	Active low input for enabling output 12. This pin has an internal pull-down. 1 = disable output, 0 = enable output.
B	11	VDDO3.3	PWR	Power supply for outputs. Nominally 3.3V.
B	12	DIF11	O, DIF	Differential true clock output.
C	1	DIF18	O, DIF	Differential true clock output.
C	2	NC	NC	No connection.
C	11	vOE11#	I, SE, PD, PDT	Active low input for enabling output 11. This pin has an internal pull-down. 1 = disable output, 0 = enable output.
C	12	DIF10#	O, DIF	Differential complementary clock output.
D	1	DIF18#	O, DIF	Differential complementary clock output.
D	2	NC	NC	No connection.
D	11	NC	NC	No connection.
D	12	DIF10	O, DIF	Differential true clock output.
E	1	DIF19	O, DIF	Differential true clock output.

Table 2. Pin Descriptions (Cont.)

Number	Name	Type	Description
E	2	vSBEN	I, SE, PD, PDT Input that enables the Side-Band Interface for controlling output enables. This pin disables the output enable pins when asserted. It has an internal pull-down resistor. 0 = OE pins and SMBus enable bits control outputs, Side-band interface disabled. 1 = Side-Band Interface controls output enables, OE pins and SMBus enable bits are disabled.
E	11	vOE10#/SHFT_LD#	I, SE, PD, PDT Active low input for enabling output 10 or SHFT_LD# pin for the Side-Band Interface. Refer to the <a href="#">Side-Band Interface</a> section for details. This pin has an internal pull-down. <b>OE mode:</b> 1 = disable output, 0 = enable output. <b>Side-Band Mode:</b> 1 = enable Side-Band Interface shift register, 0 = disable Side-Band Interface shift register. A falling edge transfers Side-Band shift register contents to output register.
E	12	vOE9#	I, SE, PD, PDT Active low input for enabling output 9. This pin has an internal pull-down. 1 = disable output, 0 = enable output.
F	1	DIF19#	O, DIF Differential complementary clock output.
F	2	NC	NC No connection.
F	11	NC	NC No connection.
F	12	DIF9#	O, DIF Differential complementary clock output.
G	1	DIF_IN	I, DIF, PDT HCSL true input.
G	2	NC	NC No connection.
G	11	NC	O, OD, PDT No connection.
G	12	DIF9	O, DIF Differential true clock output.
H	1	DIF_IN#	I, DIF, PDT HCSL complementary input.
H	2	VDDR3.3	PWR Power supply for differential input clock (receiver). This V <sub>DD</sub> should be treated as an analog power rail and filtered appropriately. Nominally 3.3V.
H	11	vOE8#	I, SE, PD, PDT Active low input for enabling output 8. This pin has an internal pull-down. 1 = disable output, 0 = enable output.
H	12	DIF8#	O, DIF Differential complementary clock output.
J	1	DIF0	O, DIF Differential true clock output.
J	2	NC	NC No connection.
J	11	NC	NC No connection.
J	12	DIF8	O, DIF Differential true clock output.
K	1	DIF0#	O, DIF Differential complementary clock output.
K	2	NC	NC No connection.
K	11	vOE7#	I, SE, PD, PDT Active low input for enabling output 7. This pin has an internal pull-down. 1 = disable output, 0 = enable output.
K	12	DIF7#	O, DIF Differential complementary clock output.
L	1	DIF1	O, DIF Differential true clock output.
L	2	VDDO3.3	PWR Power supply for outputs. Nominally 3.3V.
L	3	NC	NC No connection.

Table 2. Pin Descriptions (Cont.)

Number		Name	Type	Description
L	4	SMBDAT	I/O, SE, OD, PDT	Data pin of SMBUS circuitry.
L	5	SMBCLK	I, SE, PDT	Clock pin of SMBUS circuitry.
L	6	NC	NC	No connection.
L	7	NC	NC	No connection.
L	8	vOE5#/DATA	I, SE, PD, PDT	Active low input for enabling output 5 or the data pin for the Side-Band Interface. Refer to the <a href="#">Side-Band Interface</a> section for details. This pin has an internal pull-down. <b>OE mode:</b> 1 = disable output, 0 = enable output. <b>Side-Band mode:</b> Data pin.
L	9	NC	NC	No connection.
L	10	vOE6#/CLK	I, SE, PD, PDT	Active low input for enabling output 6 or the clock pin for the Side-Band Interface shift register. Refer to the <a href="#">Side-Band Interface</a> section for details. This pin has an internal pull-down. <b>OE mode:</b> 1 = disable output, 0 = enable output. <b>Side-Band mode:</b> Clocks data into the Side-Band Interface shift register on the rising edge.
L	11	VDDO3.3	PWR	Power supply for outputs. Nominally 3.3V.
L	12	DIF7	O, DIF	Differential true clock output.
M	1	DIF1#	O, DIF	Differential complementary clock output.
M	2	DIF2	O, DIF	Differential true clock output.
M	3	DIF2#	O, DIF	Differential complementary clock output.
M	4	DIF3	O, DIF	Differential true clock output.
M	5	DIF3#	O, DIF	Differential complementary clock output.
M	6	vCKPWRGD_PD#	I, SE, PD, PDT	Input notifies device to sample latched inputs and start up on first high assertion. Low enters Power Down mode, subsequent high assertions exit Power Down mode. This pin has internal pull-down resistor.
M	7	DIF4	O, DIF	Differential true clock output.
M	8	DIF4#	O, DIF	Differential complementary clock output.
M	9	DIF5	O, DIF	Differential true clock output.
M	10	DIF5#	O, DIF	Differential complementary clock output.
M	11	DIF6	O, DIF	Differential true clock output.
M	12	DIF6#	O, DIF	Differential complementary clock output.
-	-	EPAD	GND	Connect EPAD to ground.

## 2. Specifications

### 2.1 Absolute Maximum Ratings

**Caution:** Do not operate at or near the maximum ratings listed for extended periods of time. Exposure to such conditions can adversely impact product reliability and result in failures not covered by warranty.

Parameter	Symbol	Conditions	Minimum	Typical	Maximum	Unit
Supply Voltage <sup>[1][2]</sup>	$V_{DDx}$	-	-	-	3.9	V
Input Low Voltage <sup>[1]</sup>	$V_{IL}$	-	GND - 0.5	-	-	V
Input High Voltage <sup>[3]</sup>	$V_{IH}$	Except for SMBus interface.	-	-	$V_{DD} + 0.5$	V
Input High Voltage <sup>[1]</sup>	$V_{IHSMB}$	SMBus clock and data pins.	-	-	3.9	V
Storage Temperature <sup>[1]</sup>	$T_S$	-	-65	-	150	°C
Junction Temperature <sup>[1]</sup>	$T_J$	Maximum operating junction temperature.	-	-	125	°C
Human Body Model <sup>[1]</sup>	ESD	JESD22-A114 (JS-001) Classification.	2000	-	-	V
Charged Device Model <sup>[1]</sup>		JESD22-C101 Classification.	500	-	-	V

1. Confirmed by design and characterization, not 100% tested in production.
2. Operation under these conditions is neither implied nor guaranteed.
3. Not to exceed 3.9V.

### 2.2 Thermal Specifications

Table 3. Thermal Characteristics

Parameter	Symbol	Conditions	Package	Typical Value	Unit
Thermal Resistance	$\theta_{JC}$	Junction to case.	NHG80 <sup>[1]</sup>	44	°C/W
	$\theta_{Jb}$	Junction to base.		2	°C/W
	$\theta_{JA0}$	Junction to air, still air.		33	°C/W
	$\theta_{JA1}$	Junction to air, 1 m/s air flow.		29	°C/W
	$\theta_{JA3}$	Junction to air, 3 m/s air flow.		28	°C/W
	$\theta_{JA5}$	Junction to air, 5 m/s air flow.		27	°C/W

1. EPAD soldered to board.

### 2.3 Electrical Specifications

$T_A = T_{AMB}$ . Supply voltages per normal operation conditions; see [Test Loads](#) for loading conditions.

Table 4. SMBus

Parameter	Symbol	Conditions	Minimum	Typical	Maximum	Unit
SMBus Input Low Voltage	$V_{ILSMB}$	-	-	-	0.8	V
SMBus Input High Voltage	$V_{IHSMB}$	-	2.1	-	$V_{DDSMB}$	V
SMBus Output Low Voltage	$V_{OLSMB}$	At $I_{PULLUP}$ .	-	-	0.4	V
SMBus Sink Current	$I_{PULLUP}$	At $V_{OL}$ .	4	-	-	mA
Nominal Bus Voltage <sup>[1]</sup>	$V_{DDSMB}$	-	2.7	-	3.6	V
SCLK/SDATA Rise Time <sup>[1]</sup>	$t_{RSMB}$	(Max $V_{IL} - 0.15V$ ) to (Min $V_{IH} + 0.15V$ ).	-	-	1000	ns



Table 4. SMBus

Parameter	Symbol	Conditions	Minimum	Typical	Maximum	Unit
SCLK/SDATA Fall Time [1]	$t_{FSMB}$	(Min $V_{IH} + 0.15V$ ) to (Max $V_{IL} - 0.15V$ ).	-	-	300	ns
SMBus Operating Frequency [2]	$f_{SMB}$	SMBus operating frequency.	-	-	400	kHz

1. Confirmed by design and characterization, not 100% tested in production.
2. The device must be powered up with CKPWRGD\_PD# = '1' for the SMBus to be active.
3. Control input must be monotonic from 20% to 80% of input swing.
4. Time from deassertion until outputs are > 200mV.
5. DIF\_IN input.

Table 5. DIF\_IN Clock Input Parameters

Parameter	Symbol	Conditions	Minimum	Typical	Maximum	Unit
Input Crossover Voltage – DIF_IN [1]	$V_{CROSS}$	Crossover voltage.	100	-	900	mV
Input Swing – DIF_IN [1]	$V_{SWING}$	Differential value.	200	-	-	mV
Input Slew Rate – DIF_IN [1][2]	dv/dt	Measured differentially.	0.7	-	-	V/ns
Input Leakage Current	$I_{IN}$	CLK_IN#, $V_{IN} = 0.8V$ , CLK_IN, $V_{IN} = V_{DD}$ .	-150	-	40	$\mu A$
Input Duty Cycle [1]	$d_{tin}$	Measurement from differential waveform.	45	-	55	%

1. Confirmed by design and characterization, not 100% tested in production.
2. Slew rate measured through  $\pm 75mV$  window centered around differential zero.

Table 6. Input/Supply/Common Parameters

Parameter	Symbol	Conditions	Minimum	Typical	Maximum	Unit
Supply Voltage	$V_{DDx}$	Supply voltage for core and analog.	2.97	3.3	3.63	V
Ambient Operating Temperature	$T_{AMB}$	Industrial range.	-40	25	105	$^{\circ}C$
Input High Voltage	$V_{IH}$	Single-ended inputs, except SMBus, tri-level inputs.	2	-	$V_{DD} + 0.3$	V
Input Low Voltage	$V_{IL}$	Single-ended inputs, except SMBus, tri-level inputs.	GND - 0.3	-	0.8	V
Input High Voltage	$V_{IH}$	Tri-level inputs.	2.2	-	$V_{DD} + 0.3$	V
Input Mid Voltage	$V_{IM}$	Tri-level inputs.	1.2	$V_{DD}/2$	1.8	V
Input Low Voltage	$V_{IL}$	Tri-level inputs.	GND - 0.3	-	0.8	V
Input Current	$I_{IN}$	Single-ended inputs, $V_{IN} = GND$ , $V_{IN} = V_{DD}$ .	-5	-	5	$\mu A$
	$I_{INP}$	Single-ended inputs. $V_{IN} = 0V$ ; inputs with internal pull-up resistors. $V_{IN} = V_{DD}$ ; inputs with internal pull-down resistors.	-50	-	50	$\mu A$
Input Frequency	$F_{IN}$	$V_{DD} = 3.3V$ .	1	-	400	MHz
Pin Inductance [1]	$L_{pin}$			-	7	nH
Capacitance	$C_{IN}$	Logic inputs, except DIF_IN. [1]	1.5	-	5	pF
	$C_{INDIF\_IN}$	DIF_IN differential clock inputs. [1][2]	1.5	-	2.7	pF
	$C_{OUT}$	Output pin capacitance. [1]	-	-	6	pF

Table 6. Input/Supply/Common Parameters (Cont.)

Parameter	Symbol	Conditions	Minimum	Typical	Maximum	Unit
Clk Stabilization [1][3]	$T_{STAB}$	From $V_{DD}$ power-up and after input clock stabilization or deassertion of PD# to 1st clock.	-	1.2	3	ms
OE# Latency [1][3][4]	$t_{LATO\#}$	DIF start after OE# assertion. DIF stop after OE# deassertion.	4	5	10	clocks
Tdrive_PD# [1][4]	$t_{DRVPD}$	DIF output enable after PD# deassertion.	-	0.3	1	ms
Tfall [3]	$t_F$	Fall time of control inputs.	-	-	5	ns
Trise [3]	$t_R$	Rise time of control inputs.	-	-	5	ns

1. Confirmed by design and characterization, not 100% tested in production.
2. DIF\_IN input.
3. Time from deassertion until outputs are > 200mV.
4. Control input must be monotonic from 20% to 80% of input swing.

Table 7. Side-Band Interface

Parameter	Symbol	Conditions	Minimum	Typical	Maximum	Unit
Clock Period	$t_{PERIOD}$	Clock period.	40	-	-	ns
Setup Time to Clock	$t_{SETUP}$	SHFT setup to CLK rising edge.	10	-	-	ns
Data Setup Time	$t_{DSU}$	DATA setup to CLK rising edge.	5	-	-	ns
Data Hold Time [1]	$t_{DHOLD}$	DATA hold after CLK rising edge.	2	-	-	ns
Delay Time [1]	$t_{DELAY}$	Delay from CLK rising edge to LD# falling edge.	10	-	-	ns
Propagation Delay [2]	$t_{PD}$	Delay from LD# falling edge to next output configuration taking effect.	4	-	10	clocks
Slew Rate [3]	$t_{SLEW}$	CLK input (between 20% and 80%).	0.7	-	4	V/ns

1. Confirmed by design and characterization, not 100% tested in production.
2. Refers to device differential input clock.
3. Control input must be monotonic from 20% to 80% of input swing.

Table 8. LP-HCSL Outputs Driving High Impedance Receiver at 100MHz

Parameter	Symbol	Conditions	Minimum	Typical	Maximum	Industry Limit	Unit
Maximum Voltage [1][2]	$V_{max}$	Measurement on single ended signal using absolute value. (scope averaging off).	-	875	1010	1150	mV
Minimum Voltage [1][2][3][4]	$V_{min}$		-91	6	-	-300	
Voltage High [1][2]	$V_{high}$	$V_{high}$ set to 800mV.	678	810	903	N/A	mV
Voltage Low [1][2][3][4]	$V_{low}$		-88	35	123	N/A	
Slew Rate [1][3][5][6]	$dV/dt$	Scope averaging on, fast setting.	2	2.6	3.4	2 to 5	V/ns
Rise/Fall Matching [1][7]	$\Delta t_R/t_F$	Single-ended measurement.	-	3.6	19	20	%
Crossing Voltage (abs) [1][3][8]	$V_{cross\_abs}$	Scope averaging off.	278	412	543	250 to 550	mV
Crossing Voltage (var) [1][3][8]	$\Delta V_{cross}$	Scope averaging off.	-	10	57	140	mV

1. At default SMBus settings.

2. Includes 300mV of overshoot for Vmax and 300mV of undershoot for Vmin.
3. Confirmed by design and characterization, not 100% tested in production.
4. Vcross is defined as voltage where Clock = Clock# measured on a component test board and only applies to the differential rising edge (i.e. Clock rising and Clock# falling).
5. Measured from differential waveform.
6. Slew rate is measured through the Vswing voltage range centered around differential 0 V. This results in a ±150mV window around differential 0V.
7. Matching applies to rising edge rate for Clock and falling edge rate for Clock#. It is measured using a ±75mV window centered on the average cross point where Clock rising meets Clock# falling. The median cross point is used to calculate the voltage thresholds the oscilloscope is to use for the edge rate calculations.
8. The total variation of all Vcross measurements in any particular system. Note that this is a subset of Vcross\_min/max (Vcross absolute) allowed. The intent is to limit Vcross induced modulation by setting ?-Vcross to be smaller than Vcross absolute.

**Table 9. Current Consumption**

Parameter	Symbol	Conditions	Minimum	Typical	Maximum	Unit
Operating Supply Current	I <sub>DDVDD + VDDA</sub>	Source termination, all outputs 100MHz, C <sub>L</sub> = 2pF; Z <sub>o</sub> = 85Ω.	-	218	234	mA
	I <sub>DDR</sub>		-	0.45	0.6	
Powerdown Current	I <sub>DD_PD</sub>	All VDD's except VDDR, CKPWRGD_PD# = 0.	-	3.3	5	mA
	I <sub>DDR_PD</sub>	VDDR, CKPWRGD_PD# = 0.	-	0.6	1	

**Table 10. Skew and Differential Jitter Parameters**

Parameter	Symbol	Conditions	Minimum	Typical	Maximum	Unit
CLK_IN, DIF[x:0] [1][2][3][4][5][6]	t <sub>PD</sub>	Input-to-output skew.	1.2	1.4	1.6	ns
CLK_IN, DIF[x:0] [1][2][3][5][7]	t <sub>PDVARIATION</sub>	Input-to-output skew variation for a single device over temperature and voltage.	1.1	1.2	1.4	ps/°C
DIF[x:0] [1][2][3][6]	t <sub>SKREW_ALL</sub>	Output-to-output skew across all outputs.	-	37	50	ps
Duty Cycle Distortion [1][6][8]	t <sub>DCD</sub>	Measured differentially at 100MHz.	-0.5	-0.1	0.5	%

1. Measured into fixed 2pF load cap. Input to output skew is measured at the first output edge following the corresponding input. Default SMBus settings unless otherwise noted.
2. Measured from differential cross-point to differential cross-point.
3. All input-to-output specs refer to the timing between an input edge and the specific output edge created by it.
4. Measured with scope averaging on to find mean value.
5. Confirmed by design and characterization, not 100% tested in production.
6. Measured from differential waveform.
7. This is the amount of input-to-output delay variation with respect to temperature. This is equivalent to 250ps from -40°C to +85°C.
8. Duty cycle distortion is the difference in duty cycle between the output and the input clock.

**Table 1. PCIe Refclk Phase Jitter - Normal Conditions [1]**

Parameter	Symbol	Conditions	Typical	Maximum	Specification Limits	Unit
Additive PCIe Phase Jitter (Common Clock Architecture)	$t_{jphPCIeG1-CC}$	PCIe Gen1 (2.5GT/s) [2][3][4]	528	623	86,000	fs pk-pk
	$t_{jphPCIeG2-CC}$	PCIe Gen2 Low Band (5GT/s) [2][3][4]	9	11	3000	fs RMS
		PCIe Gen2 High Band (5GT/s) [2][3][4]	31	37	3100	
	$t_{jphPCIeG3-CC}$	PCIe Gen3 (8GT/s) [2][3][4]	15	18	1000	
	$t_{jphPCIeG4-CC}$	PCIe Gen4 (16GT/s) [2][3][4][5][6]	15	18	500	
	$t_{jphPCIeG5-CC}$	PCIe Gen5 (32GT/s) [2][3][4][5][7]	6	7	150	
$t_{jphPCIeG6-CC}$	PCIe Gen6 (64GT/s) [2][3][5][8]	4	5	100		
Additive PCIe Phase Jitter (IR Clock Architectures - SRIS, SRNS)	$t_{jphPCIeG2-IR}$	PCIe Gen2 (5GT/s) [9]	41	48	[9]	fs RMS
	$t_{jphPCIeG3-IR}$	PCIe Gen3 (8GT/s) [9]	11	13		
	$t_{jphPCIeG4-IR}$	PCIe Gen4 (16GT/s) [6][9]	11	13		
	$t_{jphPCIeG5-IR}$	PCIe Gen5 (32GT/s) [7][9]	9	11		
	$t_{jphPCIeG6-IR}$	PCIe Gen6 (64GT/s) [8][9]	12	14		

- Differential input swing = 1600mV and input slew rate = 3.5V/ns.
- The Refclk jitter is measured after applying the filter functions found in the PCI Express Base Specification 6.0, Revision 0.9. For the exact measurement setup, see Test Loads in the data sheet. The worst case results for each data rate are summarized in this table. Equipment noise is removed from all measurements.
- Jitter measurements should be made with a capture of at least 100,000 clock cycles captured by a real-time oscilloscope (RTO) with a sample rate of 20GS/s or greater. Broadband oscilloscope noise must be minimized in the measurement. The measured PP jitter is used (no extrapolation) for RTO measurements. Alternately, jitter measurements can be used with a Phase Noise Analyzer (PNA) extending (flat) and integrating and folding the frequency content up to an offset from the carrier frequency of at least 200MHz (at 300MHz absolute frequency) below the Nyquist frequency. For PNA measurements for the 2.5GT/s data rate, the RMS jitter is converted to peak-to-peak jitter using a multiplication factor of 8.83.
- The RMS sum of the source jitter and the additive jitter (arithmetic sum for PCIe Gen1) must be less than the jitter specification listed.
- SSC spurs from the fundamental and harmonics are removed up to a cutoff frequency of 2MHz taking care to minimize removal of any non-SSC content.
- Note that 700fs RMS is to be used in channel simulations to account for additional noise in a real system.
- Note that 250fs RMS is to be used in channel simulations to account for additional noise in a real system.
- Note that 150fs RMS is to be used in channel simulations to account for additional noise in a real system.
- The PCI Express Base Specification 6.0, Revision 0.9 provides the filters necessary to calculate SRIS jitter values; it does not provide specification limits, therefore, the reference to this footnote in the Limit column. SRIS values are informative only. A common practice is to split the common clock budget in half. For 16GT/s data rates and above, the user must choose whether to use the output jitter specification, or the input jitter specification, which includes an allocation for the jitter added by the channel. Using 32GT/s, the Refclk jitter budget is 150fs RMS. One half of the Refclk jitter budget is 106fs RMS. At the clock input, the system must deliver 250fs RMS. One half of this value is 177fs RMS. If the clock is placed next to the PCIe device in an SRIS system, the channel is very short and the user can choose to use this more relaxed value as the jitter limit.

**Table 11. PCIe Refclk Phase Jitter - Degraded Conditions [1]**

Parameter	Symbol	Conditions	Typical	Maximum	Specification Limits	Unit
Additive PCIe Phase Jitter (Common Clock Architecture)	$t_{jphPCleG1-CC}$	PCIe Gen1 (2.5GT/s) [2][3][4]	692	839	86,000	fs pk-pk
	$t_{jphPCleG2-CC}$	PCIe Gen2 Low Band (5GT/s) [2][3][4]	11	14	3000	fs RMS
		PCIe Gen2 High Band (5GT/s) [2][3][4]	41	49	3100	
	$t_{jphPCleG3-CC}$	PCIe Gen3 (8GT/s) [2][3][4]	20	24	1000	
	$t_{jphPCleG4-CC}$	PCIe Gen4 (16GT/s) [2][3][4][5][6]	20	24	500	
	$t_{jphPCleG5-CC}$	PCIe Gen5 (32GT/s) [2][3][4][5][7]	8	9	150	
$t_{jphPCleG6-CC}$	PCIe Gen6 (64GT/s) [2][3][4][5][8]	5	6	100		
Additive PCIe Phase Jitter (IR Clock Architectures - SRIS, SRNS)	$t_{jphPCleG2-IR}$	PCIe Gen2 (5GT/s) [9]	52	63	N/A	fs RMS
	$t_{jphPCleG3-IR}$	PCIe Gen3 (8GT/s) [9]	14	17		
	$t_{jphPCleG4-IR}$	PCIe Gen4 (16GT/s) [6][9]	14	17		
	$t_{jphPCleG5-IR}$	PCIe Gen5 (32GT/s) [7][9]	12	15		
	$t_{jphPCleG6-IR}$	PCIe Gen6 (64GT/s) [8][9]	15	19		

- Differential input swing = 800mV and input slew rate = 1.5V/ns.
- The Refclk jitter is measured after applying the filter functions found in the PCI Express Base Specification 6.0, Revision 0.9. For the exact measurement setup, see Test Loads in the data sheet. The worst case results for each data rate are summarized in this table. Equipment noise is removed from all measurements.
- Jitter measurements should be made with a capture of at least 100,000 clock cycles captured by a real-time oscilloscope (RTO) with a sample rate of 20GS/s or greater. Broadband oscilloscope noise must be minimized in the measurement. The measured PP jitter is used (no extrapolation) for RTO measurements. Alternately, jitter measurements can be used with a Phase Noise Analyzer (PNA) extending (flat) and integrating and folding the frequency content up to an offset from the carrier frequency of at least 200MHz (at 300MHz absolute frequency) below the Nyquist frequency. For PNA measurements for the 2.5GT/s data rate, the RMS jitter is converted to peak-to-peak jitter using a multiplication factor of 8.83.
- The RMS sum of the source jitter and the additive jitter (arithmetic sum for PCIe Gen1) must be less than the jitter specification listed.
- SSC spurs from the fundamental and harmonics are removed up to a cutoff frequency of 2MHz taking care to minimize removal of any non-SSC content.
- Note that 700fs RMS is to be used in channel simulations to account for additional noise in a real system.
- Note that 250fs RMS is to be used in channel simulations to account for additional noise in a real system.
- Note that 150fs RMS is to be used in channel simulations to account for additional noise in a real system.
- The PCI Express Base Specification 6.0, Revision 0.9 provides the filters necessary to calculate SRIS jitter values; it does not provide specification limits, therefore, the reference to this footnote in the Limit column. SRIS values are informative only. A common practice is to split the common clock budget in half. For 16GT/s data rates and above, the user must choose whether to use the output jitter specification, or the input jitter specification, which includes an allocation for the jitter added by the channel. Using 32GT/s, the Refclk jitter budget is 150fs RMS. One half of the Refclk jitter budget is 106fs RMS. At the clock input, the system must deliver 250fs RMS. One half of this value is 177fs RMS. If the clock is placed next to the PCIe device in an SRIS system, the channel is very short and the user can choose to use this more relaxed value as the jitter limit.

**Table 12. Non-PCIe Refclk Phase Jitter**

Parameter	Symbol	Conditions	Typical	Maximum	Specification Limit	Unit
Additive Phase Jitter	$t_{jphDB2000Q}$	100MHz, Intel-supplied filter [1][2][3][4][5]	10	12	80	fs RMS
	$t_{jphDB2000Q}$	100MHz, Intel-supplied filter [1][2][3][5][6]	30	36	80	
Additive Phase Jitter	$t_{jph12k-20M}$	156.25MHz (12kHz to 20MHz) [1][2][4]	13	15	N/A	
	$t_{jph12k-20M}$	156.25MHz (12kHz to 20MHz) [1][2][6]	40	47	N/A	

- See [Test Loads](#) for test configuration.

2. SMA100B used as signal source.
3. The 9QXL2001C meets all legacy QPI/UPI specifications by meeting the PCIe and DB2000Q specifications listed in this document.
4. Differential input swing = 1600mV and input slew rate = 3.5V/ns.
5. The RMS sum of the source jitter and the additive jitter (arithmetic sum for PCIe Gen1) must be less than the jitter specification listed.
6. Differential input swing = 800mV and input slew rate = 1.5V/ns.

### 3. Output Control

Table 13. Output Control (SBEN = 0)

CKPWRGD_PD#	DIF_IN	Traditional Interface		Side-Band Interface		Outputs
		OEx bit Byte[2:0]	OEx# Pin	MASKx Byte[10:8]	Qx	DIFx
0	X	X	X	X	X	Low/Low
1	Running	0	X	X	X	Low/Low
		1	0	X	X	Running
		1	1	X	X	Low/Low
1	Stopped	1	0	X	X	Stopped
		1	1	X	X	Low/Low

Table 14. Output Control (SBEN = 1)

CKPWRGD_PD#	DIF_IN	Traditional Interface		Side-Band Interface		Outputs
		OEx bit Byte[2:0]	OEx# Pin	MASKx Byte[10:8]	Qx	DIFx
0	X	X	X	X	X	Low/Low
1	Running	X	X	0	0	Low/Low
		X	X	0	1	Running
		X	X	1	X	Running
1	Stopped	X	X	0	0	Low/Low
		X	X	0	1	Stopped
		X	X	1	X	Stopped

### 4. Power Management

Table 15. Power Connections

Pin Number		Description
V <sub>DD</sub>	GND	
B6, H2	EPAD	Analog
B2, B11, L2, L11	EPAD	Outputs

## 5. Output Enable Control on 9QXL2001C (DB2000QL)

### 5.1 Traditional Method

The 20-output 9QXL2001C has two methods for enabling and disabling outputs. The first is the traditional method of OE# pins and SMBus output enable bits. Outputs 5 through 12 have dedicated output enable pins and each of the 20 outputs have dedicated SMBus output enable bits in Bytes[0:2] of the SMBus register set.

### 5.2 Side-Band Interface

The second method is a simple 3-wire serial interface referred to as the Side-Band Interface (SBI). This interface consists of DATA, CLK and SHFT\_LD# pins. When the SHFT\_LD# pin is high, the rising edge of CLK can shift DATA into the shift register. After shifting data, the falling edge of SHFT\_LD# clocks the shift register contents to the Output register.

Both the SBI and the traditional interface feed common output enable/disable synchronization logic ensuring glitch free enable and disable of outputs, regardless of the method used.

Both interfaces are not active at the same time, and the SBEN pin selects which interface is active. Tying the SBEN high enables the SBI. Tying the SBEN pin low enables the traditional OE# pin/SMBus output enable interface. When the SBI is enabled, OE[7:9, 11,12]# are disabled and DATA, CLK and SHFT\_LD# are enabled on OE5#, OE6# and OE10# respectively. Additionally, SMBus registers for masking off the disable function of the shift register (0 value of a bit) become active. When set to a one, the mask register forces its respective output to 'enabled'. This prevents accidentally disabling critical outputs when using the SBI.

An SMBus read back bit in Byte 4 indicates which output enable control interface is enabled.

When the SBI is enabled, and power has been applied, the SBI is active, even if the CKPWRGD\_PD# pin indicates the part is in power down. This allows loading the shift register and transferring the contents to the output register before the assertion of CKPWRGD. Note that the mask registers are part of the normal SMBus interface and cannot be accessed when the CKPWRGD\_PD# is low. [Figure 3](#) provides a functional description of the SBI.

The SBI and the traditional SMBus output enable registers both default to the 'output enabled' state at power-up. The mask registers default to zero at power-up, allowing the shift register bits to disable their respective output. See [Figure 3](#).

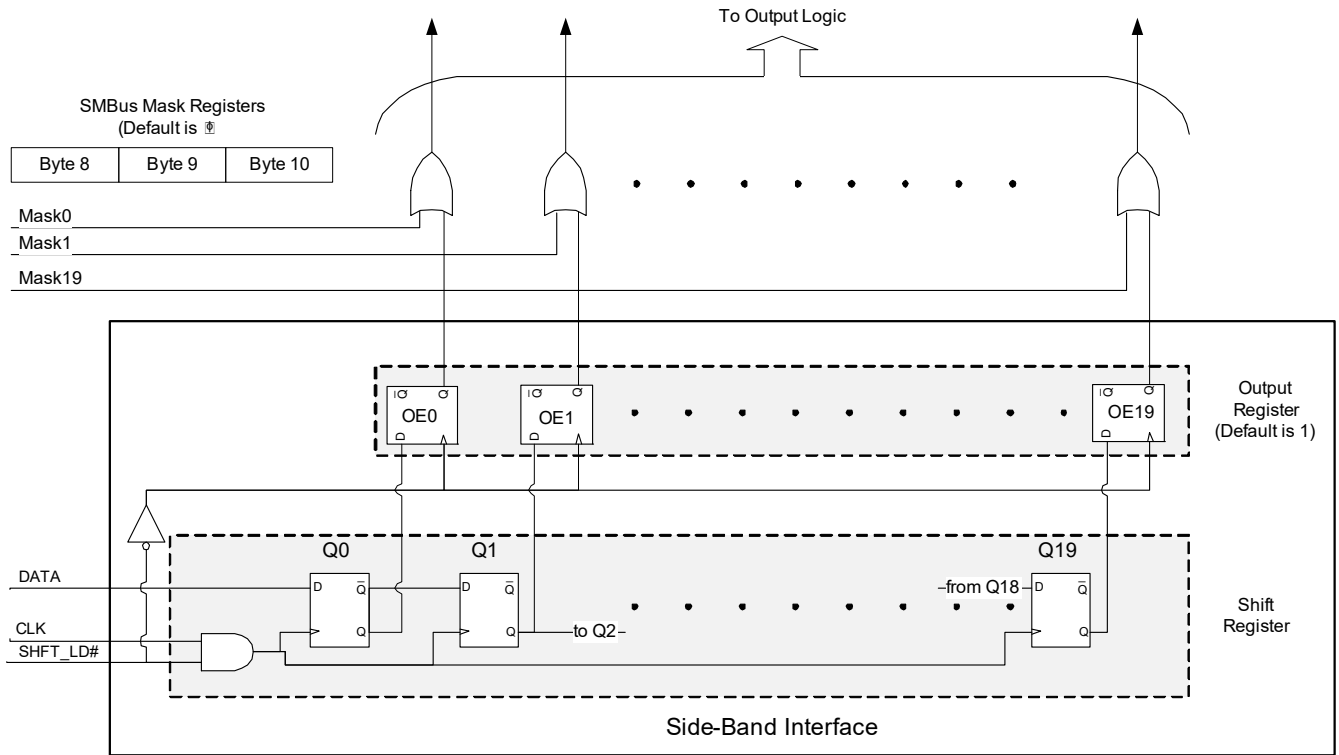

Figure 3. Side-Band Interface Control Logic – Functional Description

Figure 4 shows the basic timing of the side-band interface. The SHFT\_LD# pin goes high to enable the CLK input. Next, the rising edge of CLK clocks enable DATA into the shift register. After the 20th clock, stop the clock low and drive the SHFT\_LD# pin low. The falling edge of SHFT\_LD# clocks the shift register contents to the output register, enabling or disabling the outputs. Always shift 20 bits of data into the shift register to control the outputs.

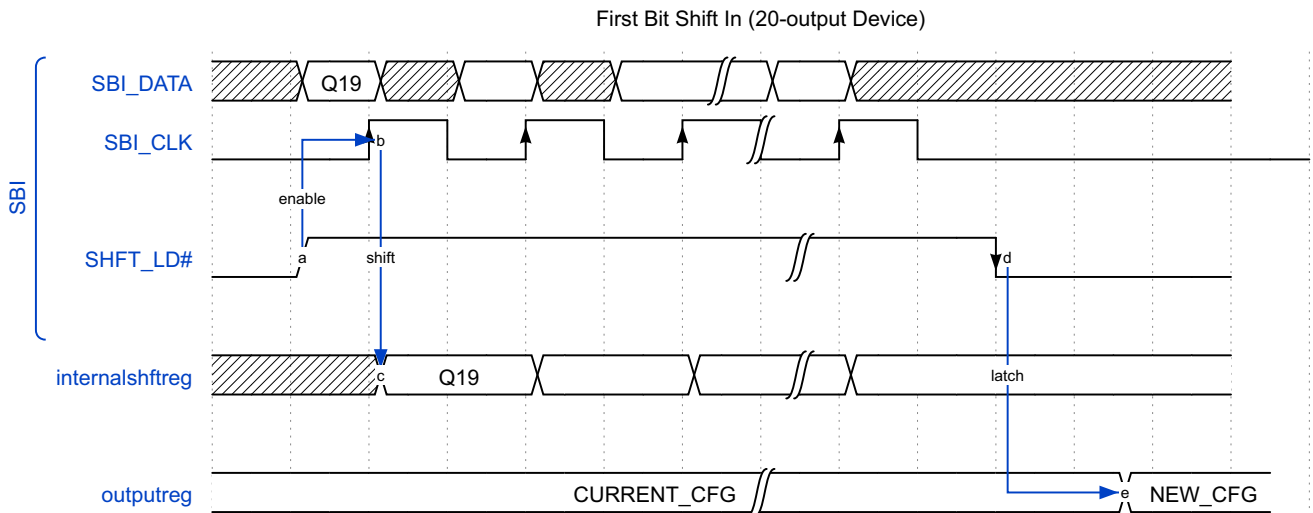

Figure 4. Side-Band Interface Functional Timing

The SBI interface supports clock rates up to 25MHz. Multiple devices may share CLK and DATA pins. Dedicating a SHFT\_LD# pin to each devices allows its use as a chip-select pin. When the SHFT\_LD# pin is low, the 9QXL2001 ignores any activity on the CLK and DATA pins.



## 6. Test Loads

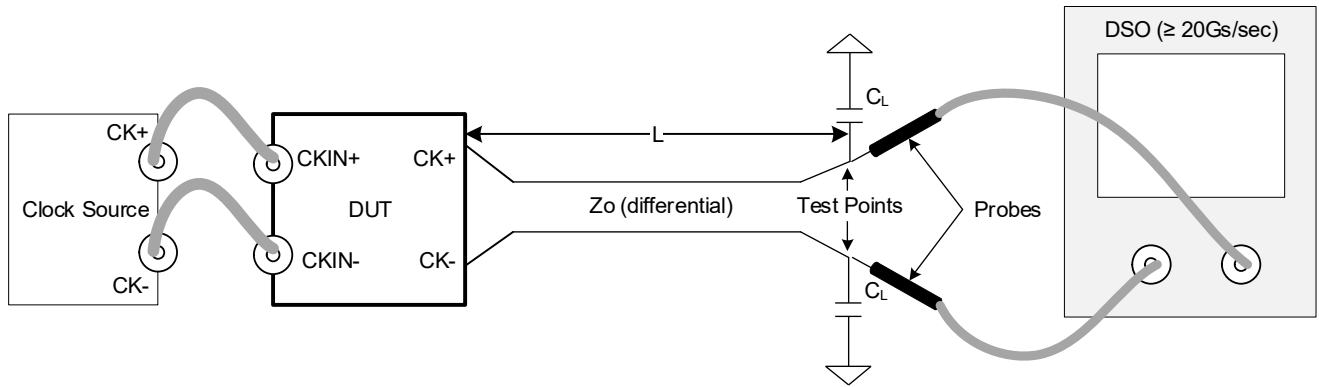

Figure 5. AC/DC Test Load for Differential Outputs (Standard PCIe Source-Termination)

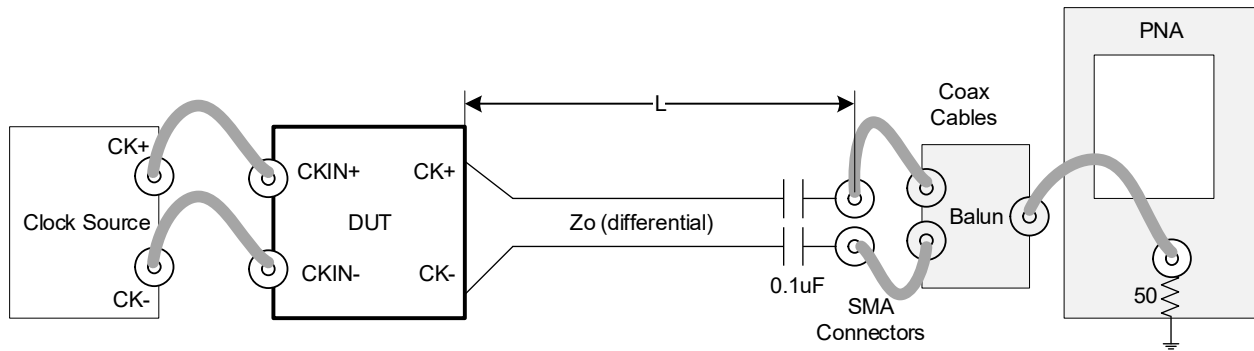

Figure 6. Test Load for Additive Phase Jitter Measurements

Table 16. Parameters for Test Loads

Clock Source	Rs ( $\Omega$ )	Zo ( $\Omega$ )	L (cm)	CL (pF)
SMA100B	Internal	85	25.4	2

Note: PCIe Gen6 specifies L = 0cm for 32 and 64 GT/s. L = 25.4cm is more conservative.

### 6.1 Alternate Terminations

The LP-HCSL output can easily drive other logic families. See [“AN-891 Driving LVPECL, LVDS, and CML Logic with “Universal” Low-Power HCSL Outputs”](#) for termination schemes for LVPECL, LVDS, CML and SSTL.

## 7. General SMBus Serial Interface Information

### 7.1 How to Write

- Controller (host) sends a start bit
- Controller (host) sends the write address
- Renesas clock will **acknowledge**
- Controller (host) sends the beginning byte location = N
- Renesas clock will **acknowledge**
- Controller (host) sends the byte count = X
- Renesas clock will **acknowledge**
- Controller (host) starts sending Byte N through Byte N+X-1
- Renesas clock will **acknowledge** each byte **one at a time**
- Controller (host) sends a stop bit

Index Block Write Operation		
Controller (Host)		Renesas (Slave/Receiver)
T	starT bit	
Slave Address		
WR	WRite	
Beginning Byte = N		ACK
		ACK
Data Byte Count = X		ACK
Beginning Byte N		ACK
O	X Byte	O
O		O
O		O
Byte N + X - 1		
		ACK
P	stoP bit	

### 7.2 How to Read

- Controller (host) will send a start bit
- Controller (host) sends the write address
- Renesas clock will **acknowledge**
- Controller (host) sends the beginning byte location = N
- Renesas clock will **acknowledge**
- Controller (host) will send a separate start bit
- Controller (host) sends the read address
- Renesas clock will **acknowledge**
- Renesas clock will send the data byte count = X
- Renesas clock sends Byte N+X-1
- Renesas clock sends **Byte 0 through Byte X (if X<sub>(H)</sub> was written to Byte 8)**
- Controller (host) will need to acknowledge each byte
- Controller (host) will send a not acknowledge bit
- Controller (host) will send a stop bit

Index Block Read Operation		
Controller (Host)		Renesas
T	starT bit	
Slave Address		
WR	WRite	
Beginning Byte = N		ACK
		ACK
RT	Repeat starT	
Slave Address		
RD	ReaD	
		ACK
		Data Byte Count = X
ACK		Beginning Byte N
ACK		O
O		O
O		O
O		
		Byte N + X - 1
N	Not	
P	stoP bit	

## 7.3 SMBus Addressing

Table 17. SMBus Address Selection

SADR(1:0)_tri	SMBus Address (Read/Write bit = 0)
00	D8
0M	DA
01	DE
M0	C2
MM	C4
M1	C6
10	CA
1M	CC
11	CE

SMBus Table: Output Enable Register (functional only when SBEN = 0)

Byte 0	Name	Control Function	Type	0	1	Default
Bit 7	Reserved					0
Bit 6	DIF_19_En	Output Enable	RW	Low/Low	Enable	1
Bit 5	DIF_18_En	Output Enable	RW	Low/Low	Enable	1
Bit 4	DIF_17_En	Output Enable	RW	Low/Low	Enable	1
Bit 3	DIF_16_En	Output Enable	RW	Low/Low	Enable	1
Bit 2	Reserved					0
Bit 1	Reserved					0
Bit 0	Reserved					0

SMBus Table: Output Enable Register (functional only when SBEN = 0)

Byte 1	Name	Control Function	Type	0	1	Default
Bit 7	DIF_7_En	Output Enable	RW	Disabled Low/Low	OE7# Controls	1
Bit 6	DIF_6_En	Output Enable	RW		OE6# Controls	1
Bit 5	DIF_5_En	Output Enable	RW		OE5# Controls	1
Bit 4	DIF_4_En	Output Enable	RW		Enabled	1
Bit 3	DIF_3_En	Output Enable	RW		Enabled	1
Bit 2	DIF_2_En	Output Enable	RW		Enabled	1
Bit 1	DIF_1_En	Output Enable	RW		Enabled	1
Bit 0	DIF_0_En	Output Enable	RW		Enabled	1

**SMBus Table: Output Enable Register (functional only when SBEN = 0)**

Byte 2	Name	Control Function	Type	0	1	Default
Bit 7	DIF_15_En	Output Enable	RW	Low/Low	Enabled	1
Bit 6	DIF_14_En	Output Enable	RW		Enabled	1
Bit 5	DIF_13_En	Output Enable	RW		Enabled	1
Bit 4	DIF_12_En	Output Enable	RW		OE12# Controls	1
Bit 3	DIF_11_En	Output Enable	RW		OE11# Controls	1
Bit 2	DIF_10_En	Output Enable	RW		OE10# Controls	1
Bit 1	DIF_9_En	Output Enable	RW		OE9# Controls	1
Bit 0	DIF_8_En	Output Enable	RW		OE8# Controls	1

**SMBus Table: OE# Pin Readback Register**

Byte 3	Name	Control Function	Type	0	1	Default
Bit 7	RB_OE12	Status of OE12#	R	Pin Low	Pin High	Real-time
Bit 6	RB_OE11	Status of OE11#	R			Real-time
Bit 5	RB_OE10	Status of OE10#	R			Real-time
Bit 4	RB_OE9	Status of OE9#	R			Real-time
Bit 3	RB_OE8	Status of OE8#	R			Real-time
Bit 2	RB_OE7	Status of OE7#	R			Real-time
Bit 1	RB_OE6	Status of OE6#	R			Real-time
Bit 0	RB_OE5	Status of OE5#	R			Real-time

**SMBus Table: SBEN Readback Register**

Byte 4	Name	Control Function	Type	0	1	Default
Bit 7		Reserved				0
Bit 6		Reserved				0
Bit 5		Reserved				0
Bit 4		Reserved				0
Bit 3		Reserved				0
Bit 2		Reserved				0
Bit 1		Reserved				0
Bit 0	RB_SBEN	Status of SBEN	R	Pin Low	Pin High	Real-time

**SMBus Table: Vendor and Revision ID Register**

Byte 5	Name	Control Function	Type	0	1	Default
Bit 7	RID3	REVISION ID	R	C rev is 0010		0
Bit 6	RID2		R			0
Bit 5	RID1		R			x
Bit 4	RID0		R			x
Bit 3	VID3	VENDOR ID	R	IDT/Renesas		0
Bit 2	VID2		R			0
Bit 1	VID1		R			0
Bit 0	VID0		R			1

**SMBus Table: Device ID**

Byte 6	Name	Control Function	Type	0	1	Default
Bit 7	Device ID 7 (MSB)		R	C9		1
Bit 6	Device ID 6		R			1
Bit 5	Device ID 5		R			0
Bit 4	Device ID 4		R			0
Bit 3	Device ID 3		R			1
Bit 2	Device ID 2		R			0
Bit 1	Device ID 1		R			x
Bit 0	Device ID 0		R			1

**SMBus Table: Byte Count Register**

Byte 7	Name	Control Function	Type	0	1	Default
Bit 7	Reserved					0
Bit 6	Reserved					0
Bit 5	Reserved					0
Bit 4	BC4	Writing to this register configures how many bytes will be read back.	RW	Default value is 7.		0
Bit 3	BC3		RW			0
Bit 2	BC2		RW			1
Bit 1	BC1		RW			1
Bit 0	BC0		RW			1

**SMBus Table: Side-Band Mask Register (functional only when SBEN = 1)**

Byte8	Name	Control Function	Type	0	1	Default
Bit 7	Mask7	Masks off Side-band Disable	RW	Side-band shift register may disable the output	Forces output to always be enabled regardless of side-band shift register value	0
Bit 6	Mask6	Masks off Side-band Disable	RW			0
Bit 5	Mask5	Masks off Side-band Disable	RW			0
Bit 4	Mask4	Masks off Side-band Disable	RW			0
Bit 3	Mask3	Masks off Side-band Disable	RW			0
Bit 2	Mask2	Masks off Side-band Disable	RW			0
Bit 1	Mask1	Masks off Side-band Disable	RW			0
Bit 0	Mask0	Masks off Side-band Disable	RW			0

**SMBus Table: Side-Band Mask Register (functional only when SBEN = 1)**

Byte 9	Name	Control Function	Type	0	1	Default
Bit 7	Mask15	Masks off Side-band Disable	RW	Side-band shift register may disable the output	Forces output to always be enabled regardless of side-band shift register value	0
Bit 6	Mask14	Masks off Side-band Disable	RW			0
Bit 5	Mask13	Masks off Side-band Disable	RW			0
Bit 4	Mask12	Masks off Side-band Disable	RW			0
Bit 3	Mask11	Masks off Side-band Disable	RW			0
Bit 2	Mask10	Masks off Side-band Disable	RW			0
Bit 1	Mask9	Masks off Side-band Disable	RW			0
Bit 0	Mask8	Masks off Side-band Disable	RW			0

**SMBus Table: Side-Band Mask Register (functional only when SBEN = 1)**

Byte 10	Name	Control Function	Type	0	1	Default
Bit 7	Reserved					0
Bit 6	Reserved					0
Bit 5	Reserved					0
Bit 4	Reserved					0
Bit 3	Mask19	Masks off Side-band Disable	RW	Side-band shift register may disable the output	Forces output to always be enabled regardless of side-band shift register value	0
Bit 2	Mask18	Masks off Side-band Disable	RW			0
Bit 1	Mask17	Masks off Side-band Disable	RW			0
Bit 0	Mask16	Masks off Side-band Disable	RW			0

Bytes 11 through 19 are Reserved.

SMBus Table: Amplitude Configuration Register

Byte 20	Name	Control Function	Type	0	1	Default
Bit 7	AMP[3]	Global Differential output Control	RW	0.6V – 1V, 25mV/step Default=800mV		0
Bit 6	AMP[2]		RW			1
Bit 5	AMP[1]		RW			1
Bit 4	AMP[0]		RW			1
Bit 3	Reserved					0
Bit 2	Reserved					1
Bit 1	Reserved					1
Bit 0	Reserved					1

SMBus Table: PD\_RESTORE

Byte 21	Name	Control Function	Type	0	1	Default
Bit 7	Reserved					0
Bit 6	Reserved					0
Bit 5	Reserved					0
Bit 4	Reserved					0
Bit 3	PD_RESTORE#	Save Configuration in Power Down	RW	Config Cleared	Config Saved	1
Bit 2	Reserved					0
Bit 1	Reserved					0
Bit 0	Reserved					0

## 8. Package Outline Drawings

The package outline drawings are located at the end of this document and are accessible from the Renesas website. The package information is the most current data available and is subject to change without revision of this document.

## 9. Marking Diagram

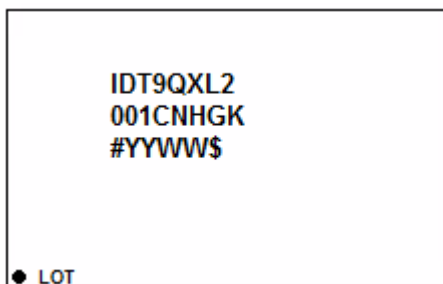

- Lines 1 and 2: part number
  - “K” denotes temperature rating.
- Line 3:
  - “#” denotes the stepping number.
  - “YYWW” is the last digits of the year and work week that the part was assembled.
  - “\$” denotes mark code.
- “LOT” denotes the lot sequence code.

## 10. Ordering Information

Part Number [1][2]	Package Description	Carrier Type	Temperature Range
9QXL2001CNHGK	6.00 × 6.00 mm, 0.50mm pitch 80-GQFN	Tray	-40° to +105°C
9QXL2001CNHGK8	6.00 × 6.00 mm, 0.50mm pitch 80-GQFN	Tape and Reel	-40° to +105°C
9QXL2001CNHGK/n [3]	6.00 × 6.00 mm, 0.50mm pitch 80-GQFN	Tray	-40° to +105°C
9QXL2001CNHGK8/n [3]	6.00 × 6.00 mm, 0.50mm pitch 80-GQFN	Tape and Reel	-40° to +105°C
9QXL2001CNHGK8/W	6.00 × 6.00 mm, 0.50mm pitch 80-GQFN	Tape and Reel, Pin 1 Orientation: EIA-481-D (see <Hyperlink>Table 18)	-40° to +105°C

1. “C” is the device revision designator (will not correlate with the datasheet revision).
2. “G” designates PB-free configuration, RoHS compliant.
3. “n” is an alphanumeric character for specific customer requests or tracking.

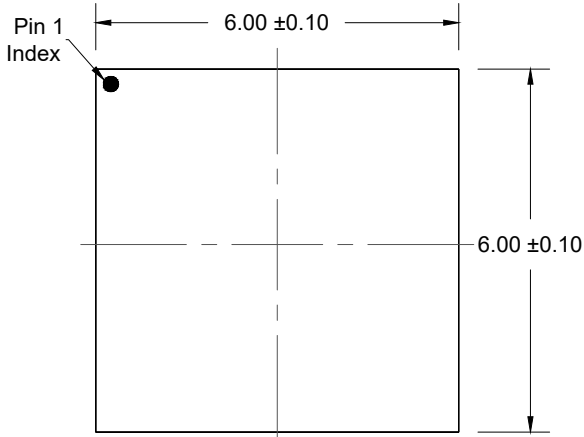

Table 18. Pin 1 Orientation in Tape and Reel Packaging

Part Number Suffix	Pin 1 Orientation	Illustration
8	Quadrant 1 (EIA-481-C)	
/W	Quadrant 2 (EIA-481-D)	

## 11. Revision History

Revision	Date	Description
1.07	Sep 27, 2023	Reformatted to the latest template.
-	Jul 19, 2023	<ul style="list-style-type: none"> <li>Updated Clk Stabilization and Tdrive_PD# values in <a href="#">Table 6</a>.</li> <li>Updated Maximum/Minimum Voltage and Slew Rate values in <a href="#">Table 8</a>.</li> <li>Updated Operating Supply Current values in <a href="#">Table 9</a>.</li> </ul>
-	May 19, 2023	<ul style="list-style-type: none"> <li>Added 9QXL2001CNHGK8/W part number in <a href="#">Ordering Information</a>.</li> <li>Added <a href="#">Table 18</a>.</li> </ul>
-	Oct 6, 2022	Added 9QXL2001CNHGK/n and 9QXL2001CNHGK8/n to <a href="#">Ordering Information</a> .
-	Apr 8, 2022	Added <a href="#">Signal Types</a> table and updated <a href="#">Pin Descriptions</a> table with latest nomenclature.
-	Nov 9, 2021	Updated with characterization data; move to final.
-	Jul 19, 2023	<ul style="list-style-type: none"> <li>Updated Clk Stabilization and Tdrive_PD# values in <a href="#">Table 6</a>.</li> <li>Updated Maximum/Minimum Voltage and Slew Rate values in <a href="#">Table 8</a>.</li> <li>Updated Operating Supply Current values in <a href="#">Table 9</a>.</li> </ul>
-	Oct 4, 2021	Initial release.



TOP VIEW

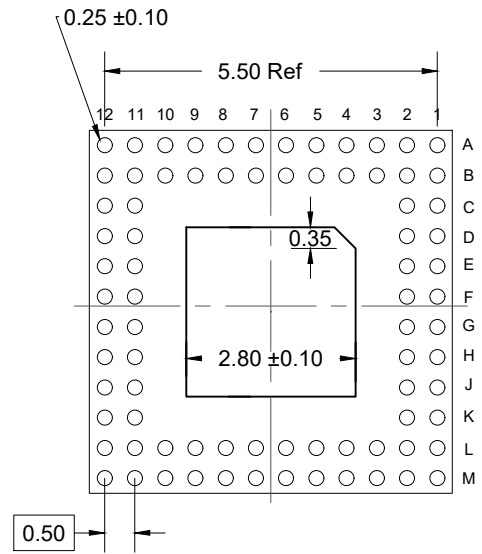

BOTTOM VIEW

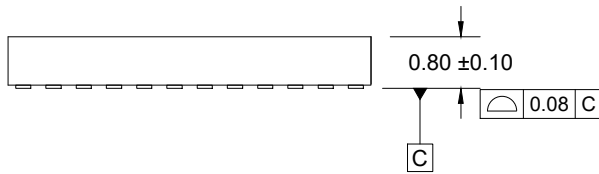

SIDE VIEW

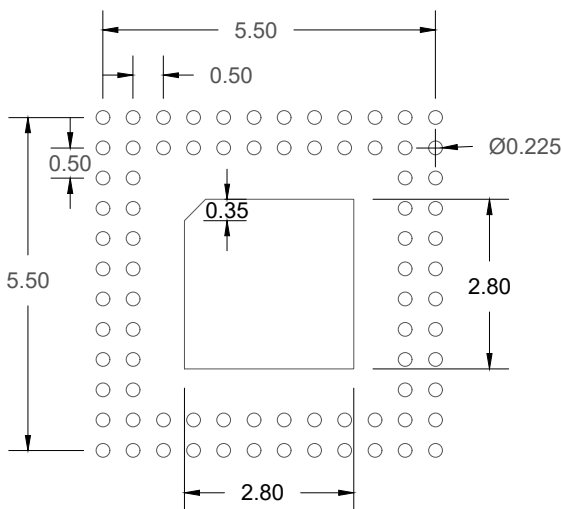

RECOMMENDED LAND PATTERN

(PCB Top View, NSMD Design)

**NOTES:**

1. JEDEC compatible
2. All dimensions are in mm and angles are in degrees
3. Use  $\pm 0.05$  mm tolerance for all other dimensions
4. Numbers in ( ) are for reference only

## IMPORTANT NOTICE AND DISCLAIMER

RENESAS ELECTRONICS CORPORATION AND ITS SUBSIDIARIES (“RENESAS”) PROVIDES TECHNICAL SPECIFICATIONS AND RELIABILITY DATA (INCLUDING DATASHEETS), DESIGN RESOURCES (INCLUDING REFERENCE DESIGNS), APPLICATION OR OTHER DESIGN ADVICE, WEB TOOLS, SAFETY INFORMATION, AND OTHER RESOURCES “AS IS” AND WITH ALL FAULTS, AND DISCLAIMS ALL WARRANTIES, EXPRESS OR IMPLIED, INCLUDING, WITHOUT LIMITATION, ANY IMPLIED WARRANTIES OF MERCHANTABILITY, FITNESS FOR A PARTICULAR PURPOSE, OR NON-INFRINGEMENT OF THIRD PARTY INTELLECTUAL PROPERTY RIGHTS.

These resources are intended for developers skilled in the art designing with Renesas products. You are solely responsible for (1) selecting the appropriate products for your application, (2) designing, validating, and testing your application, and (3) ensuring your application meets applicable standards, and any other safety, security, or other requirements. These resources are subject to change without notice. Renesas grants you permission to use these resources only for development of an application that uses Renesas products. Other reproduction or use of these resources is strictly prohibited. No license is granted to any other Renesas intellectual property or to any third party intellectual property. Renesas disclaims responsibility for, and you will fully indemnify Renesas and its representatives against, any claims, damages, costs, losses, or liabilities arising out of your use of these resources. Renesas' products are provided only subject to Renesas' Terms and Conditions of Sale or other applicable terms agreed to in writing. No use of any Renesas resources expands or otherwise alters any applicable warranties or warranty disclaimers for these products.

(Disclaimer Rev.1.0 Mar 2020)

### Corporate Headquarters

TOYOSU FORESIA, 3-2-24 Toyosu,  
Koto-ku, Tokyo 135-0061, Japan  
[www.renesas.com](http://www.renesas.com)

### Contact Information

For further information on a product, technology, the most up-to-date version of a document, or your nearest sales office, please visit:  
[www.renesas.com/contact/](http://www.renesas.com/contact/)

### Trademarks

Renesas and the Renesas logo are trademarks of Renesas Electronics Corporation. All trademarks and registered trademarks are the property of their respective owners.