



1.8V Low-Power Wide-Range Frequency Clock Driver

Recommended Application:

- DDR2 Memory Modules / Zero Delay Board Fan Out
- Provides complete DDR2 DIMM logic solution

Product Description/Features:

- Low skew, low jitter PLL clock driver
- 1 to 10 differential clock distribution (SSTL_18)
- Feedback pins for input to output synchronization
- Spread Spectrum tolerant inputs
- Auto PD when input signal is at a certain logic state

Switching Characteristics:

- Period jitter: 40ps (DDR2-400/533)
30ps (DDR2-667/800)
- Half-period jitter: 60ps (DDR2-400/533)
50ps (DDR2-667/800)
- OUTPUT - OUTPUT skew: 40ps (DDR2-400/533)
30ps (DDR2-667/800)
- CYCLE - CYCLE jitter 40ps

Pin Configuration

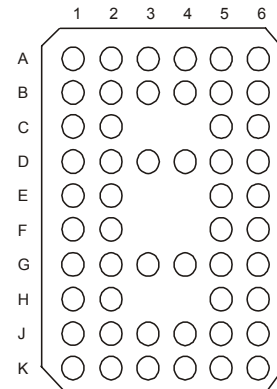

52-Ball BGA

Top View

	1	2	3	4	5	6
A	CLKT1	CLKT0	CLKC0	CLKC5	CLKT5	CLKT6
B	CLKC1	GND	GND	GND	GND	CLKC6
C	CLKC2	GND	NB	NB	GND	CLKC7
D	CLKT2	VDDQ	VDDQ	VDDQ	OS	CLKT7
E	CLK_INT	VDDQ	NB	NB	VDDQ	FB_INT
F	CLK_INC	VDDQ	NB	NB	OE	FB_INC
G	AGND	VDDQ	VDDQ	VDDQ	VDDQ	FB_OUTC
H	AVDD	GND	NB	NB	GND	FB_OUTT
J	CLKT3	GND	GND	GND	GND	CLKT8
K	CLKC3	CLKC4	CLKT4	CLKT9	CLKC9	CLKC8

Block Diagram

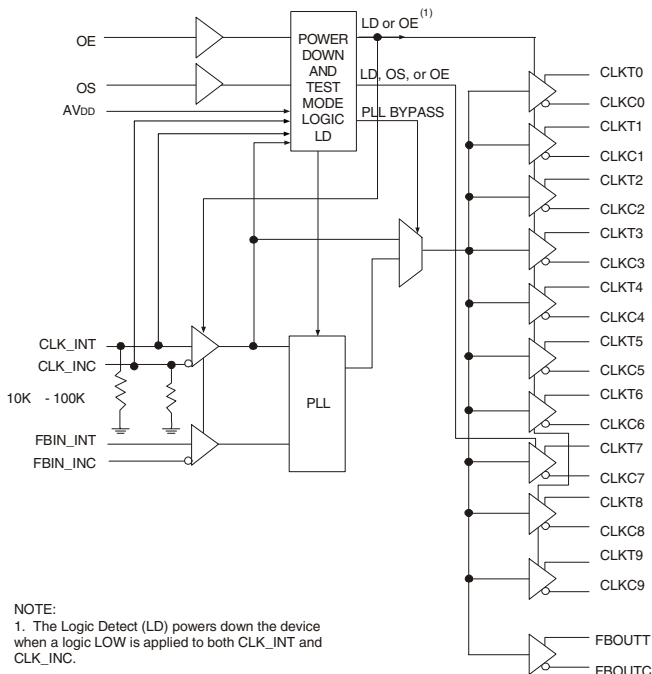

NOTE:
1. The Logic Detect (LD) powers down the device when a logic LOW is applied to both CLK_INT and CLK_INC.

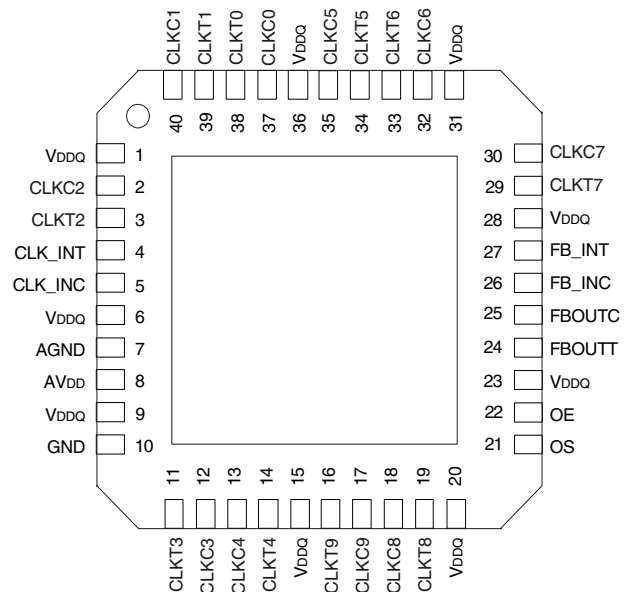

40-Pin MLF

Pin Descriptions

Terminal Name	Description	Electrical Characteristics
AGND	Analog Ground	Ground
AV _{DD}	Analog power	1.8 V nominal
CLK_INT	Clock input with a (10K-100K Ohm) pulldown resistor	Differential input
CLK_INC	Complementary clock input with a (10K-100K Ohm) pulldown resistor	Differential input
FB_INT	Feedback clock input	Differential input
FB_INC	Complementary feedback clock input	Differential input
FB_OUTT	Feedback clock output	Differential output
FB_OUTC	Complementary feedback clock output	Differential output
OE	Output Enable (Asynchronous)	LVC MOS input
OS	Output Select (tied to GND or V _{DDQ})	LVC MOS input
GND	Ground	Ground
V _{DDQ}	Logic and output power	1.8V nominal
CLKT[0:9]	Clock outputs	Differential outputs
CLKC[0:9]	Complementary clock outputs	Differential outputs
NB	No ball	

The PLL clock buffer, **ICS98ULPA877A**, is designed for a V_{DDQ} of 1.8 V, a AV_{DD} of 1.8 V and differential data input and output levels. Package options include a plastic 52-ball VFBGA and a 40-pin MFL.

ICS98ULPA877A is a zero delay buffer that distributes a differential clock input pair (CLK_INT, CLK_INC) to ten differential pair of clock outputs (CLKT[0:9], CLKC[0:9]) and one differential pair feedback clock outputs (FB_OUTT, FB_OUTC). The clock outputs are controlled by the input clocks (CLK_INT, CLK_INC), the feedback clocks (FB_INT, FB_INC), the LVC MOS program pins (OE, OS) and the Analog Power input (AV_{DD}). When OE is low, the outputs (except FB_OUTT/FB_OUTC) are disabled while the internal PLL continues to maintain its locked-in frequency. OS (Output Select) is a program pin that must be tied to GND or V_{DDQ}. When OS is high, OE will function as described above. When OS is low, OE has no effect on CLKT7/CLKC7 (they are free running in addition to FB_OUTT/FB_OUTC). When AV_{DD} is grounded, the PLL is turned off and bypassed for test purposes.

When both clock signals (CLK_INT, CLK_INC) are logic low, the device will enter a low power mode. An input logic detection circuit on the differential inputs, independent from the input buffers, will detect the logic low level and perform a low power state where all outputs, the feedback and the PLL are OFF. When the inputs transition from both being logic low to being differential signals, the PLL will be turned back on, the inputs and outputs will be enabled and the PLL will obtain phase lock between the feedback clock pair (FB_INT, FB_INC) and the input clock pair (CLK_INT, CLK_INC) within the specified stabilization time t_{STAB}.

The PLL in **ICS98ULPA877A** clock driver uses the input clocks (CLK_INT, CLK_INC) and the feedback clocks (FB_INT, FB_INC) to provide high-performance, low-skew, low-jitter output differential clocks (CLKT[0:9], CLKC[0:9]). **ICS98ULPA877A** is also able to track Spread Spectrum Clocking (SSC) for reduced EMI.

ICS98ULPA877A is available in Commercial Temperature Range (0°C to 70°C) and Industrial Temperature Range (-40°C to +85°C). See Ordering Information for details

Function Table

Inputs					Outputs				PLL
AVDD	OE	OS	CLK_INT	CLK_INC	CLKT	CLKC	FB_OUTT	FB_OUTC	
GND	H	X	L	H	L	H	L	H	Bypassed/Off
GND	H	X	H	L	H	L	H	L	Bypassed/Off
GND	L	H	L	H	*L(Z)	*L(Z)	L	H	Bypassed/Off
GND	L	L	H	L	*L(Z), CLKT7 active	*L(Z), CLKC7 active	H	L	Bypassed/Off
1.8V(nom)	L	H	L	H	*L(Z)	*L(Z)	L	H	On
1.8V(nom)	L	L	H	L	*L(Z), CLKT7 active	*L(Z), CLKC7 active	H	L	On
1.8V(nom)	H	X	L	H	L	H	L	H	On
1.8V(nom)	H	X	H	L	H	L	H	L	On
1.8V(nom)	X	X	L	L	*L(Z)	*L(Z)	*L(Z)	*L(Z)	Off
1.8V(nom)	X	X	H	H	Reserved				

*L(Z) means the outputs are disabled to a low stated meeting the I_{ODL} limit.

Absolute Maximum Ratings

Supply Voltage (VDDQ & AVDD)	-0.5V to 2.5V
Logic Inputs	GND - 0.5V to V _{DDQ} + 0.5V
Ambient Operating Temperature	-40°C to +85°C
Storage Temperature	-65°C to +150°C

Stresses above those listed under *Absolute Maximum Ratings* may cause permanent damage to the device. These ratings are stress specifications only and functional operation of the device at these or any other conditions above those listed in the operational sections of the specifications is not implied. Exposure to absolute maximum rating conditions for extended periods may affect product reliability.

Electrical Characteristics - Input/Supply/Common Output Parameters

Commercial: TA = 0°C - 70°C; Industrial: TA = -40°C - +85°C;
 Supply Voltage AVDDQ, VDDQ = 1.8 V +/- 0.1V (unless otherwise stated)

PARAMETER	SYMBOL	CONDITIONS	MIN	TYP	MAX	UNITS
Input High Current (CLK_INT, CLK_INC)	I _{IH}	V _I = V _{DDQ} or GND			±250	μA
Input Low Current (OE, OS, FB_INT, FB_INC)	I _{IL}	V _I = V _{DDQ} or GND			±10	μA
Output Disabled Low Current	I _{ODL}	OE = L, V _{ODL} = 100mV	100			μA
Operating Supply Current	I _{DD1.8}	C _L = 0pf @ 410MHz			300	mA
	I _{DDL}	C _L = 0pf			500	μA
Input Clamp Voltage	V _{IK}	V _{DDQ} = 1.7V I _{in} = -18mA			-1.2	V
High-level output voltage	V _{OH}	I _{OH} = -100 μA	V _{DDQ} - 0.2			V
		I _{OH} = -9 mA	1.1	1.45		V
Low-level output voltage	V _{OL}	I _{OL} = 100 μA		0.25	0.10	V
		I _{OL} = 9 mA			0.6	V
Input Capacitance ¹	C _{IN}	V _I = GND or V _{DDQ}	2		3	pF
Output Capacitance ¹	C _{OUT}	V _{OUT} = GND or V _{DDQ}	2		3	pF

¹Guaranteed by design, not 100% tested in production.

Recommended Operating Condition (see note1)

Commercial: TA = 0°C - 70°C; Industrial: TA = -40°C - +85°C;

Supply Voltage AVDDQ, VDDQ = 1.8 V +/- 0.1V (unless otherwise stated)

PARAMETER	SYMBOL	CONDITIONS	MIN	TYP	MAX	UNITS
Supply Voltage	V _{DDQ} , A _{VDD}		1.7	1.8	1.9	V
Low level input voltage	V _{IL}	CLK_INT, CLK_INC, FB_INC, FB_INT			0.35 x V _{DDQ}	V
		OE, OS			0.35 x V _{DDQ}	V
High level input voltage	V _{IH}	CLK_INT, CLK_INC, FB_INC, FB_INT	0.65 x V _{DDQ}			V
		OE, OS	0.65 x V _{DDQ}			V
DC input signal voltage (note 2)	V _{IN}		-0.3		V _{DDQ} + 0.3	V
Differential input signal voltage (note 3)	V _{ID}	DC - CLK_INT, CLK_INC, FB_INC, FB_INT	0.3		V _{DDQ} + 0.4	V
		AC - CLK_INT, CLK_INC, FB_INC, FB_INT	0.6		V _{DDQ} + 0.4	V
Output differential cross-voltage (note 4)	V _{OX}		V _{DDQ} /2 - 0.10		V _{DDQ} /2 + 0.10	V
Input differential cross-voltage (note 4)	V _{IX}		V _{DDQ} /2 - 0.15	V _{DD} /2	V _{DDQ} /2 + 0.15	V
High level output current	I _{OH}				-9	mA
Low level output current	I _{OL}				9	mA
Operating free-air temperature	T _A		-40		85	°C

Notes:

- Unused inputs must be held high or low to prevent them from floating.
- DC input signal voltage specifies the allowable DC execution of differential input.
- Differential inputs signal voltages specifies the differential voltage [VTR-VCP] required for switching, where VTR is the true input level and VCP is the complementary input level.
- Differential cross-point voltage is expected to track variations of V_{DDQ} and is the voltage at which the differential signal must be crossing.

Timing Requirements

Commercial: TA = 0°C - 70°C; Industrial: TA = -40°C - +85°C;

Supply Voltage AVDDQ, VDDQ = 1.8 V +/- 0.1V (unless otherwise stated)

PARAMETER	SYMBOL	CONDITIONS	MIN	MAX	UNITS
Max clock frequency	freq _{op}	1.8V±0.1V @ 25°C	95	410	MHz
Application Frequency Range	freq _{App}	1.8V±0.1V @ 25°C	160	410	MHz
Input clock duty cycle	d _{tin}		40	60	%
CLK stabilization	T _{STAB}			15	µs

NOTE: The PLL must be able to handle spread spectrum induced skew.

NOTE: Operating clock frequency indicates a range over which the PLL must be able to lock, but in which it is not required to meet the other timing parameters. (Used for low speed system debug.)

NOTE: Application clock frequency indicates a range over which the PLL must meet all timing parameters.

NOTE: Stabilization time is the time required for the integrated PLL circuit to obtain phase lock of its feedback signal to its reference signal, within the value specified by the Static Phase Offset (t_{ϕ}), after power-up. During normal operation, the stabilization time is also the time required for the integrated PLL circuit to obtain phase lock of its feedback signal to its reference signal when CK and CK# go to a logic low state, enter the power-down mode and later return to active operation. CK and CK# may be left floating after they have been driven low for one complete clock cycle.

Switching Characteristics¹

Commercial: TA = 0°C - 70°C; Industrial: TA = -40°C - +85°C;

Supply Voltage AVDDQ, VDDQ = 1.8 V +/- 0.1V (unless otherwise stated)

PARAMETER	SYMBOL	CONDITION	(MHz)	MIN	TYP	MAX	UNITS
Output enable time	t_{en}	OE to any output	160 to 410		4.73	8	ns
Output disable time	t_{dis}	OE to any output			5.82	8	ns
Period jitter	$t_{jit(per)}$		160 to 270	-40		40	ps
			271 to 410	-30		30	ps
Half-period jitter	$t_{jit(hper)}$		160 to 270	-60		60	ps
			271 to 410	-50		50	ps
Input slew rate	SLr1(i)	Input Clock	160 to 410	1	2.5	4	v/ns
		Output Enable (OE), (OS)		0.5			v/ns
Output clock slew rate	SLr1(o)		160 to 410	1.5	2.5	3	v/ns
Cycle-to-cycle period jitter	$t_{jit(cc+)}$			0		40	ps
	$t_{jit(cc-)}$			0		-40	ps
Dynamic Phase Offset	$t_{(\phi)dyn}$		160 to 270	-50		50	ps
			271 to 410	-20		20	ps
Static Phase Offset	t_{SPO}^2		271 to 410	-50	0	50	ps
$t_{jit(per)} + t_{(\phi)dyn} + t_{skew(o)}$	$\sum_{(su)}$					80	ps
$t_{(\phi)dyn} + t_{skew(o)}$	$\sum_{(h)}$					60	ps
Output to Output Skew	t_{skew}		160 to 270			40	ps
			271 to 410			30	ps
SSC modulation frequency				30.00		33	kHz
SSC clock input frequency deviation				0.00		-0.50	%
PLL Loop bandwidth (-3 dB from unity gain)				2.0			MHz

Notes:

1. Switching characteristics guaranteed for application frequency range.
2. Static phase offset shifted by design.

Parameter Measurement Information

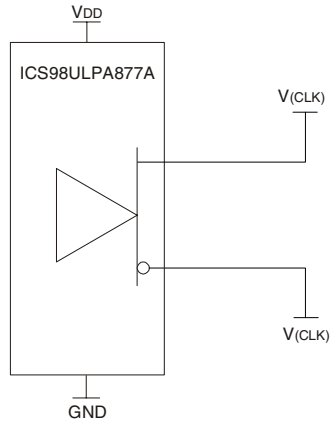

Figure 1: IBIS Model Output Load

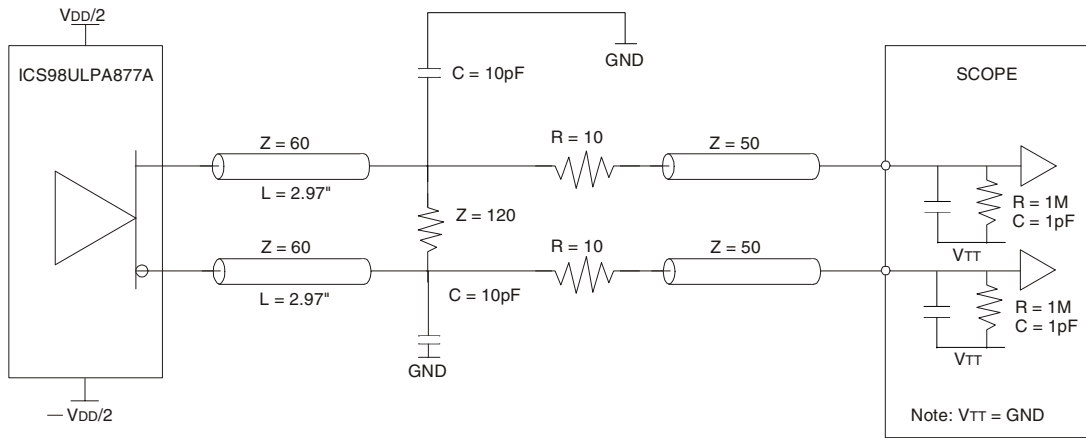

Figure 2: Output Load Test Circuit

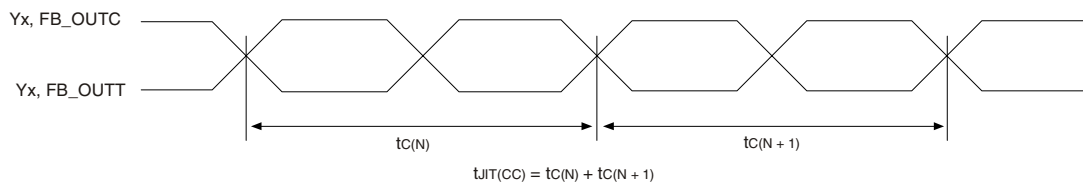

Figure 3: Cycle-to-Cycle Jitter

Parameter Measurement Information

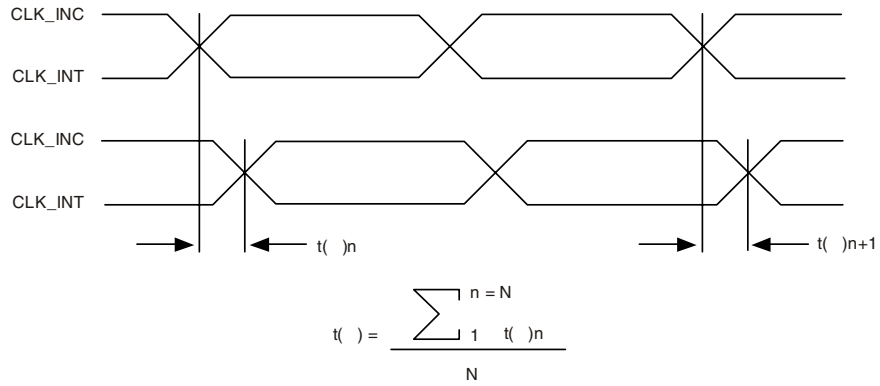

Figure 4: Static Phase Offset

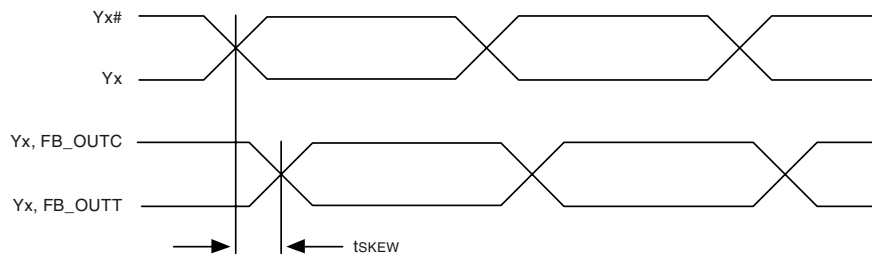

Figure 5: Output Skew

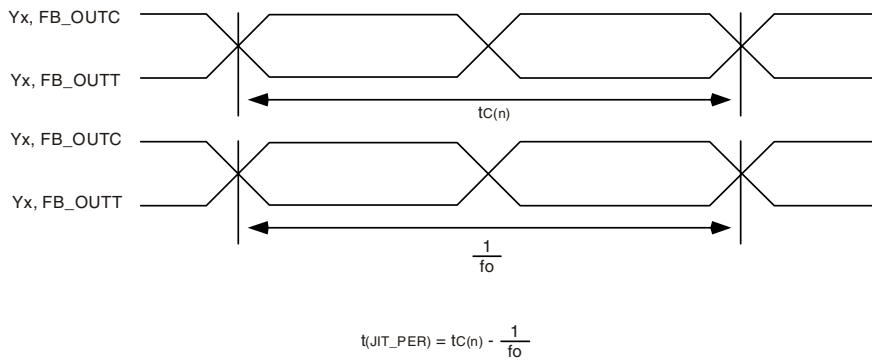
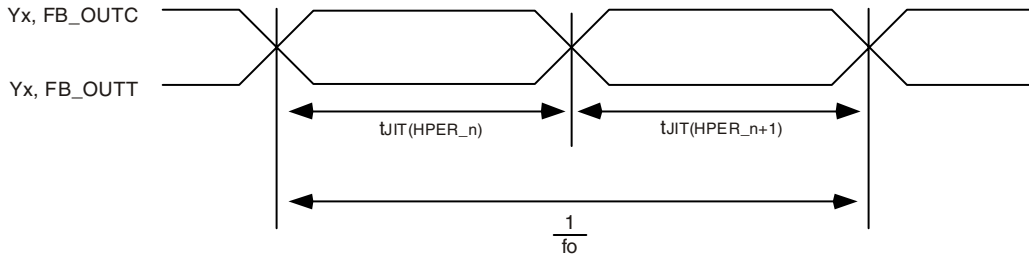

Figure 6: Period Jitter

Parameter Measurement Information



$$t_{JIT(HPER)} = t_{JIT(HPER_n)} - \frac{1}{2f_o}$$

Figure 7: Half-Period Jitter

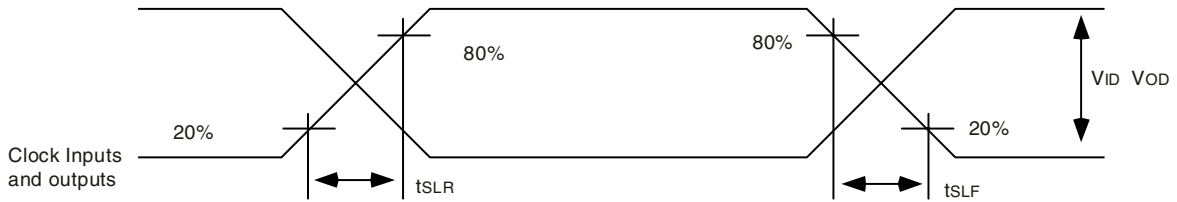

Figure 8: Input and Output Slew Rates

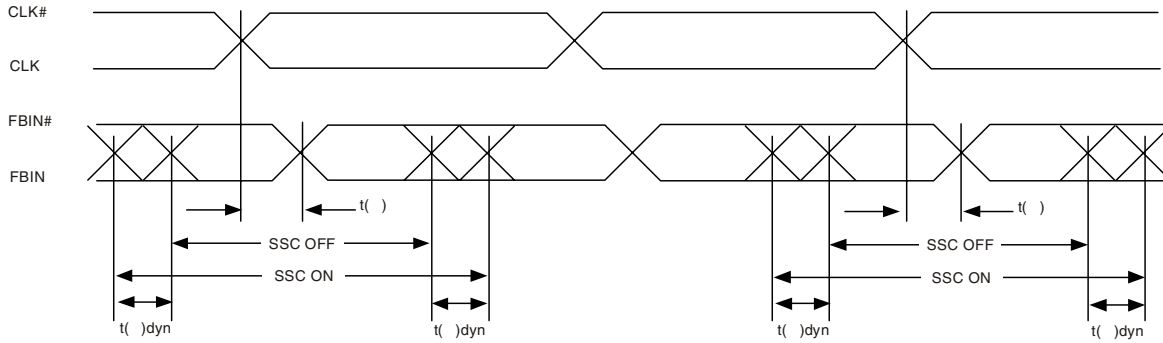

Figure 9: Dynamic Phase Offset

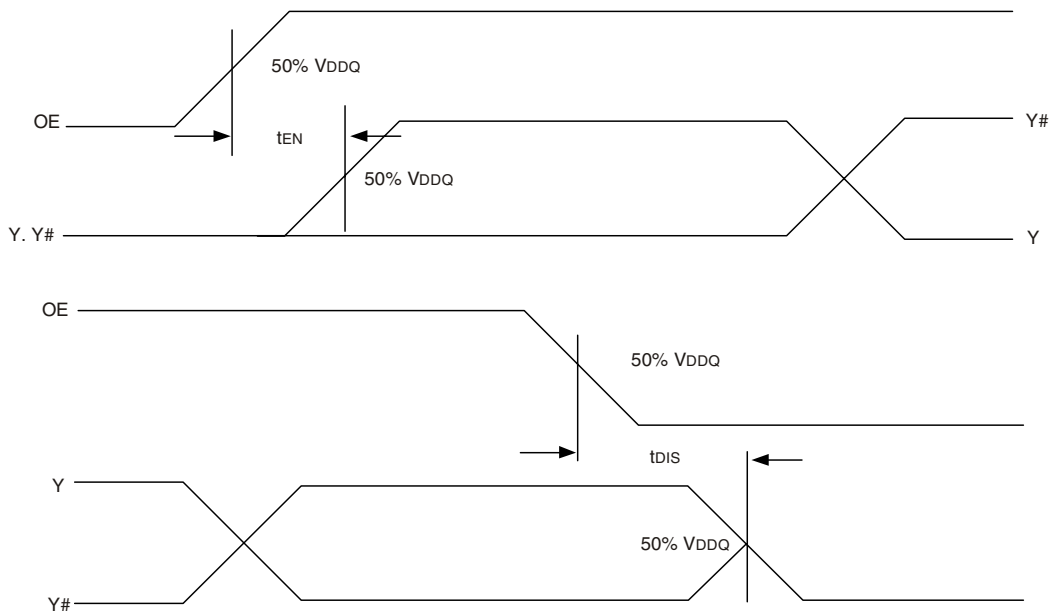

Figure 10: Time Delay Between OE and Clock Output (Y, Y#)

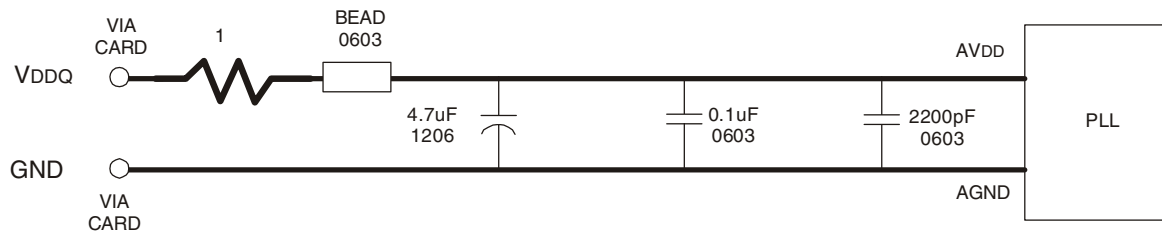
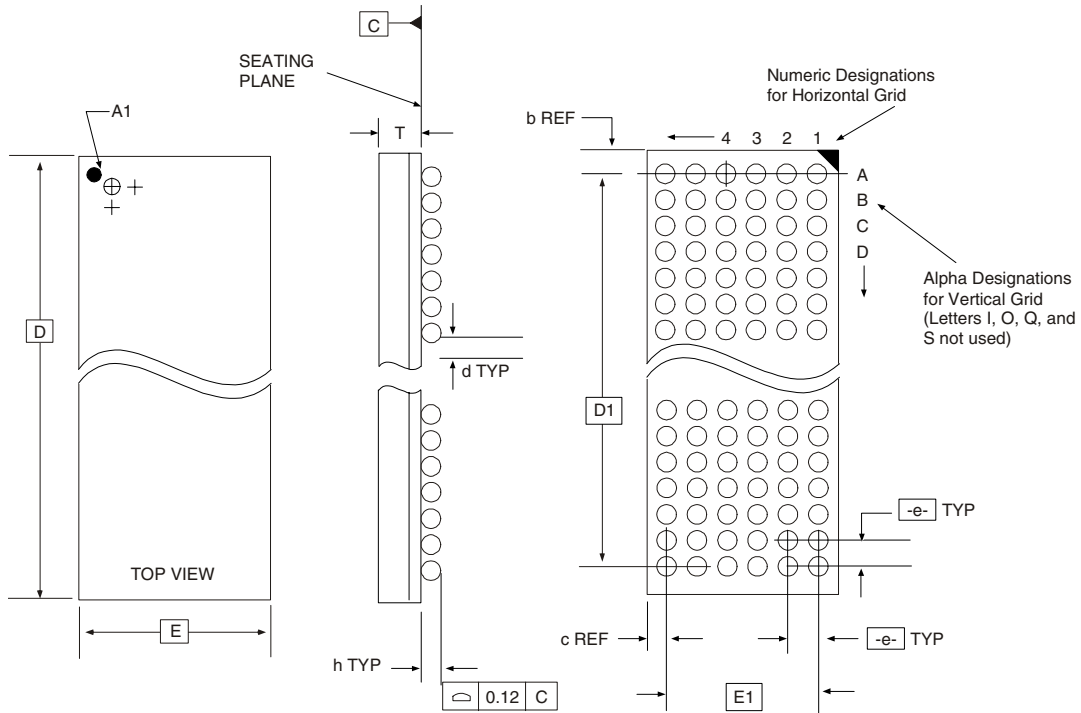

Figure 11. AVDD Filtering

- *Place the 2200pF capacitors close to the PLL.
- *Use wide traces for PLL Analog power and GND. Connect PLL and caps to AGND trace and connect trace to one GND via (farthest from PLL).
- *Recommended bead: Fair-rite P/N 2506036017Y0 or equivalent (0.8 DC max., 600 at 100MHz).



ALL DIMENSIONS IN MILLIMETERS

D	E	T Min/Max	e	BALL GRID		Max. TOTAL	d Min/Max	h Min/Max	D1	E1	REF. DIMENSIONS	
				HORIZ	VERT						b	c
7.00 Bsc	4.50 Bsc	0.86/1.00	0.65 Bsc	6	10	60	0.25/0.45	0.15/0.31	5.85 Bsc	3.25 Bsc	0.575	0.625

Note: Ball grid total indicates maximum ball count for package. Lesser quantity may be used.

* Source Ref.: JEDEC Publication 95, MO-205*, MO-225**

10-0055

Ordering Information

98ULPA877AHLFT

Example:

XXXX y H z LF T

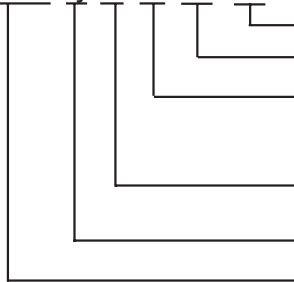

Designation for tape and reel packaging

Lead Free, RoHS Compliant (Optional)

Temperature Grade

Blank = 0°C to +70°C (Commercial)

I = -40°C to +85°C (Industrial)

Package Type

H = BGA

Revision Designator (will not correlate with datasheet revision)

Device Type

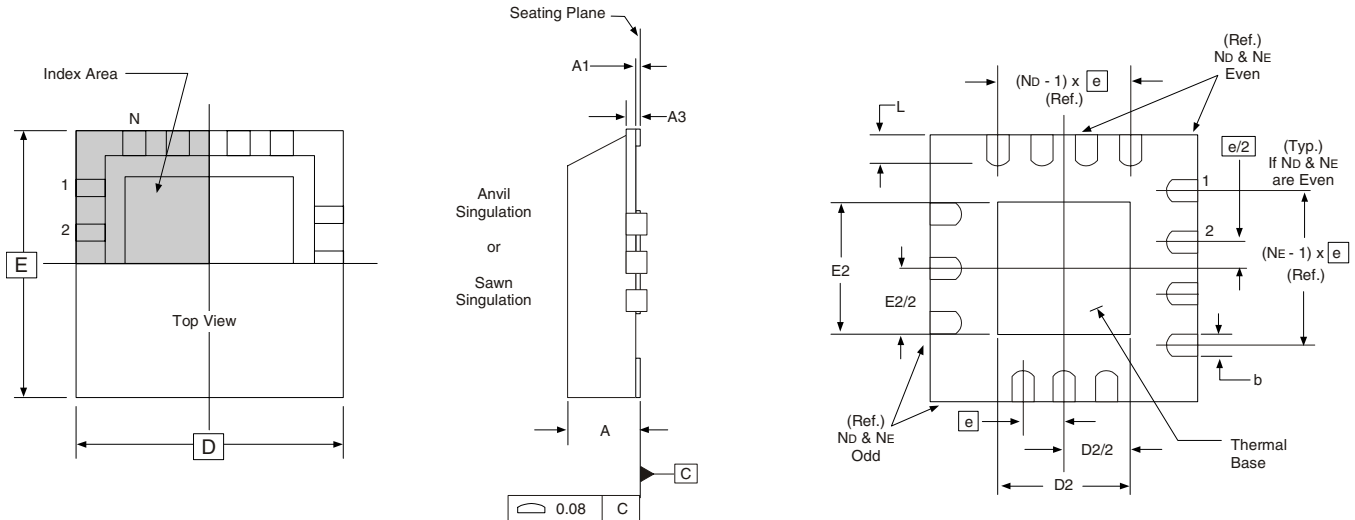

**THERMALLY ENHANCED, VERY THIN, FINE PITCH
QUAD FLAT / NO LEAD PLASTIC PACKAGE**

ALL DIMENSIONS IN MILLIMETERS

		SYMBOL	MIN.	MAX.
N	40			
N _D	10	A	0.80	1.00
N _E	10	A1	0	0.05
D x E BASIC	6.00 x 6.00	A3	0.25 Reference	
D2 MIN. / MAX.	2.75 / 3.05	b	0.18	0.30
E2 MIN. / MAX.	2.75 / 3.05	e	0.50 BASIC	
L MIN. / MAX.	0.30 / 0.50			

Source Reference: MLF2™ †
10-0053

Ordering Information

98ULPA877AKLFT

Example:

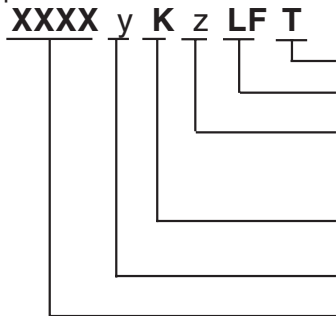

Designation for tape and reel packaging

Lead Free, RoHS Compliant (Optional)

Temperature Grade

Blank = 0°C to +70°C (Commercial)

I = -40°C to +85°C (Industrial)

Package Type

K = MLF

Revision Designator (will not correlate with datasheet revision)

Device Type

IMPORTANT NOTICE AND DISCLAIMER

RENESAS ELECTRONICS CORPORATION AND ITS SUBSIDIARIES (“RENESAS”) PROVIDES TECHNICAL SPECIFICATIONS AND RELIABILITY DATA (INCLUDING DATASHEETS), DESIGN RESOURCES (INCLUDING REFERENCE DESIGNS), APPLICATION OR OTHER DESIGN ADVICE, WEB TOOLS, SAFETY INFORMATION, AND OTHER RESOURCES “AS IS” AND WITH ALL FAULTS, AND DISCLAIMS ALL WARRANTIES, EXPRESS OR IMPLIED, INCLUDING, WITHOUT LIMITATION, ANY IMPLIED WARRANTIES OF MERCHANTABILITY, FITNESS FOR A PARTICULAR PURPOSE, OR NON-INFRINGEMENT OF THIRD PARTY INTELLECTUAL PROPERTY RIGHTS.

These resources are intended for developers skilled in the art designing with Renesas products. You are solely responsible for (1) selecting the appropriate products for your application, (2) designing, validating, and testing your application, and (3) ensuring your application meets applicable standards, and any other safety, security, or other requirements. These resources are subject to change without notice. Renesas grants you permission to use these resources only for development of an application that uses Renesas products. Other reproduction or use of these resources is strictly prohibited. No license is granted to any other Renesas intellectual property or to any third party intellectual property. Renesas disclaims responsibility for, and you will fully indemnify Renesas and its representatives against, any claims, damages, costs, losses, or liabilities arising out of your use of these resources. Renesas' products are provided only subject to Renesas' Terms and Conditions of Sale or other applicable terms agreed to in writing. No use of any Renesas resources expands or otherwise alters any applicable warranties or warranty disclaimers for these products.

(Rev.1.0 Mar 2020)

Corporate Headquarters

TOYOSU FORESIA, 3-2-24 Toyosu,
Koto-ku, Tokyo 135-0061, Japan
www.renesas.com

Contact Information

For further information on a product, technology, the most up-to-date version of a document, or your nearest sales office, please visit:
www.renesas.com/contact/

Trademarks

Renesas and the Renesas logo are trademarks of Renesas Electronics Corporation. All trademarks and registered trademarks are the property of their respective owners.