

## Description

The 8T74S208B is a high-performance differential LVDS clock divider and fanout buffer. The device is designed for the frequency division and signal fanout of high-frequency, low phase-noise clocks. The 8T74S208B is characterized to operate from a 2.5V power supply. Guaranteed output-to-output and part-to-part skew characteristics make the 8T74S208B ideal for those clock distribution applications demanding well-defined performance and repeatability. The integrated input termination resistors make interfacing to the reference source easy and reduce passive component count. Each output can be individually enabled or disabled in the high-impedance state controlled by a I<sup>2</sup>C register. On power-up, all outputs are enabled.

## Features

- One differential input reference clock
- Differential pair can accept the following differential input levels: LVDS, LVPECL, CML
- Integrated input termination resistors
- Eight LVDS outputs
- Selectable clock frequency division of ÷1, ÷2, ÷4 and ÷8
- Maximum input clock frequency: 1GHz
- LVC MOS interface levels for the control inputs
- Individual output enabled/ disabled by I<sup>2</sup>C interface
- Output skew: 45ps (maximum)
- Output rise/fall times: 370ps (maximum)
- Low additive phase jitter, RMS: 96fs (typical)
- Full 2.5V supply voltage
- Outputs enabled at power up
- Lead-free (RoHS 6) 32-Lead VFQFN packaging
- -40°C to 85°C ambient operating temperature

## Block Diagram

Figure 1: Block Diagram

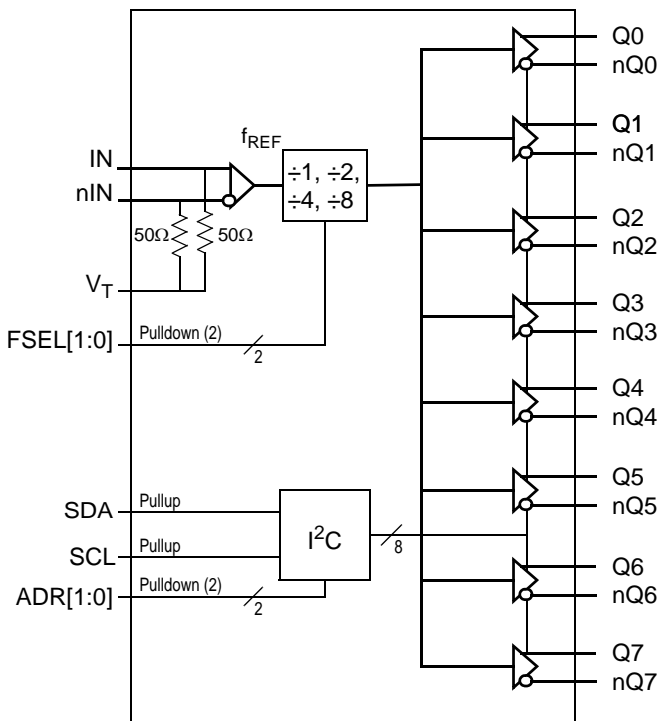

## Pin Assignments

Figure 2: Pin Assignments for 5mm x 5mm 32-Lead Package – Top View

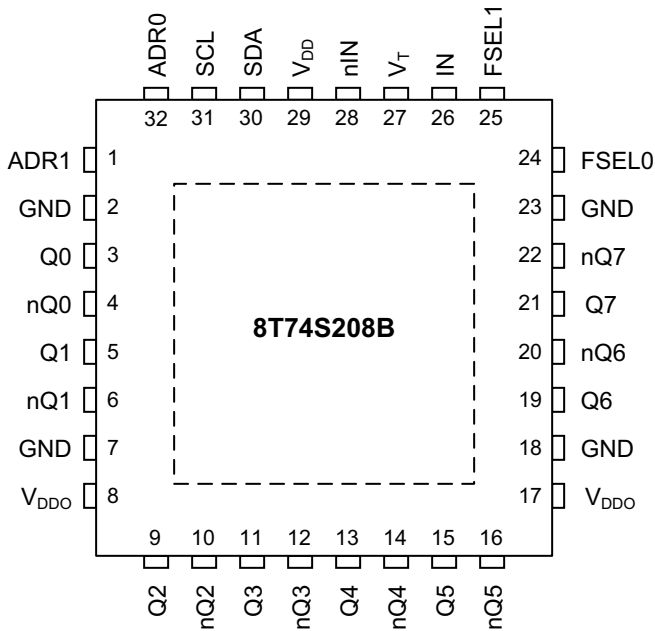

## Pin Descriptions and Pin Characteristics

Table 1: Pin Descriptions <sup>[a]</sup>,

Number	Name	Type		Description
1	ADR1	Input	Pulldown	I <sup>2</sup> C Address input. LVCMOS/LVTTL interface levels.
2	GND	Power		Ground pin.
3	Q0	Output		Differential output pair 0. LVDS interface levels.
4	nQ0	Output		
5	Q1	Output		Differential output pair 1. LVDS interface levels.
6	nQ1	Output		
7	GND	Power		Ground pin.
8	V <sub>DDO</sub>	Power		Output supply pin.
9	Q2	Output		Differential output pair 2. LVDS interface levels.
10	nQ2	Output		
11	Q3	Output		Differential output pair 3. LVDS interface levels.
12	nQ3	Output		
13	Q4	Output		Differential output pair 4. LVDS interface levels.
14	nQ4	Output		
15	Q5	Output		Differential output pair 5. LVDS interface levels.
16	nQ5	Output		
17	V <sub>DDO</sub>	Power		Output supply pin.

Table 1: Pin Descriptions <sup>[a]</sup>, (Cont.)

Number	Name	Type		Description
18	GND	Power		Ground pin.
19	Q6	Output		Differential output pair 6. LVDS interface levels.
20	nQ6	Output		
21	Q7	Output		Differential output pair 7. LVDS interface levels.
22	nQ7	Output		
23	GND	Power		Ground pin.
24	FSEL0	Input	Pulldown	Frequency divider select controls. See <a href="#">Table 3</a> for function. LVCMOS/LVTTL interface levels.
25	FSEL1	Input	Pulldown	Frequency divider select controls. See <a href="#">Table 3</a> for function. LVCMOS/LVTTL interface levels.
26	IN	Input		Non-inverting differential clock input. $R_T = 50\Omega$ termination to $V_T$ .
27	$V_T$	Termination Input		Input for termination. Both IN and nIN inputs are internally terminated $50\Omega$ to this pin. See input termination information in the applications section.
28	nIN	Input		Inverting differential clock input. $R_T = 50\Omega$ termination to $V_T$ .
29	$V_{DD}$	Power		Power supply pin.
30	SDA	I/O	Pullup	$I^2C$ Data Input/Output. Input: LVCMOS/LVTTL interface levels. Output: open drain.
31	SCL	Input	Pullup	$I^2C$ Clock Input. LVCMOS/LVTTL interface levels.
32	ADR0	Input	Pulldown	$I^2C$ Address input. LVCMOS/LVTTL interface levels.

a. *Pulldown* and *Pullup* refer to internal input resistors. See [Table 2, Pin Characteristics](#), for typical values.

Table 2: Pin Characteristics

Symbol	Parameter	Test Conditions	Minimum	Typical	Maximum	Units
$C_{IN}$	Input Capacitance			2		pF
$R_{PULDDOWN}$	Input Pulldown Resistor			51		$k\Omega$
$R_{PULLUP}$	Input Pullup Resistor			51		$k\Omega$

## Function Tables

### Input Frequency Divider Operation

The FSEL1 and FSEL0 control pins configure the input frequency divider. In the default state (FSEL[1:0] are set to logic 0:0 or left open) the output frequency is equal to the input frequency (divide-by-1). The other FSEL[1:0] settings configure the input divider to divide-by-2, 4 or 8, respectively.

Table 3: FSEL[1:0] Input Selection Function Table <sup>[a]</sup>

Input		Operation
FSEL1	FSEL0	
0 (default)	0 (default)	$f_{Q[7:0]} = f_{REF} \div 1$
0	1	$f_{Q[7:0]} = f_{REF} \div 2$
1	0	$f_{Q[7:0]} = f_{REF} \div 4$
1	1	$f_{Q[7:0]} = f_{REF} \div 8$

a. FSEL1, FSEL0 are asynchronous controls.

### Output Enable Operation

The output enable/disable state of each individual differential output Qx, nQx can be set by the content of the I<sup>2</sup>C register (see [Table 5](#)). A logic zero to an I<sup>2</sup>C bit in register 0 enables the corresponding differential output, while a logic one disables the differential output (see [Table 4](#)). After each power cycle, the device resets all I<sup>2</sup>C bits (Dn) to its default state (logic 0) and all Qx, nQx outputs are enabled. After the first valid I<sup>2</sup>C write, the output enable state is controlled by the I<sup>2</sup>C register. Setting and changing the output enable state through the I<sup>2</sup>C interface is asynchronous to the input reference clock.

Table 4: Individual Output Enable Control

Bit	Operation
Dn	
0 (default)	Output Qx, nQx is enabled.
1	Output Qx, nQx is disabled in high-impedance state.

Table 5: Individual Output Enable Control

Bit	D7	D6	D5	D4	D3	D2	D1	D0
Output	Q7	Q6	Q5	Q4	Q3	Q2	Q1	Q0
Default	0	0	0	0	0	0	0	0

## I<sup>2</sup>C Interface Protocol

The 8T74S208B uses an I<sup>2</sup>C slave interface for writing and reading the device configuration to and from the on-chip configuration registers. This device uses the standard I<sup>2</sup>C write format for a write transaction, and a standard I<sup>2</sup>C read format for a read transaction. Figure 3 defines the I<sup>2</sup>C elements of the standard I<sup>2</sup>C transaction. These elements consist of a start bit, data bytes, an acknowledge or Not-Acknowledge bit and the stop bit. These elements are arranged to make up the complete I<sup>2</sup>C transactions as shown in Figure 4 and Figure 5. Figure 4 is a write transaction while Figure 5 is a read transaction. The 7-bit I<sup>2</sup>C slave address of the 8T74S208B is a combination of a 5-bit fixed address and two variable bits which are set by the hardware pins ADR[1:0] (binary 11010, ADR1, ADR0). Bit 0 of slave address is used by the bus controller to select either the read or write mode. The hardware pins ADR1 and ADR0 should be individually set by the user to avoid address conflicts of multiple 8T74S208B devices on the same bus.

Table 6: I<sup>2</sup>C Slave Address

7	6	5	4	3	2	1	0
1	1	0	1	0	ADR1	ADR0	R/W

Figure 3: Standard I<sup>2</sup>C Transaction

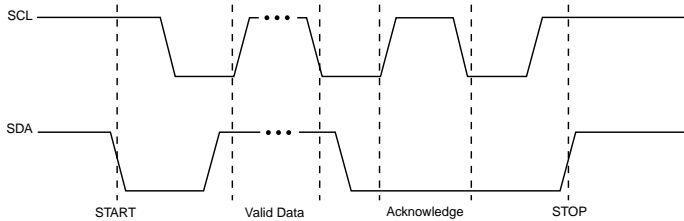

**START (S)** – defined as high-to-low transition on SDA while holding SCL HIGH.

**DATA** – between START and STOP cycles, SDA is synchronous with SCL. Data may change only when SCL is LOW and must be stable when SCL is HIGH.

**ACKNOWLEDGE (A)** – SDA is driven LOW before the SCL rising edge and held LOW until the SCL falling edge.

**STOP (P)** – defined as low-to-high transition on SDA while holding SCL HIGH.

Figure 4: Write Transaction

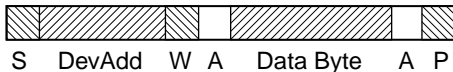
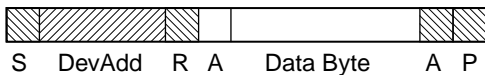

Figure 5: Read Transaction



- S** – Start or Repeated Start
- W** – R/W is set for Write
- R** – R/W is set for Read
- A** – Ack
- DevAdd** – 7 bit Device Address
- P** – Stop

## Absolute Maximum Ratings

NOTE: Stresses beyond those listed under *Absolute Maximum Ratings* may cause permanent damage to the device. These ratings are stress specifications only. Functional operation of product at these conditions or any conditions beyond those listed in the [DC Electrical Characteristics](#) or [AC Electrical Characteristics](#) is not implied. Exposure to absolute maximum rating conditions for extended periods may affect product reliability.

Table 7: Absolute Maximum Ratings

Item	Rating
Supply Voltage, $V_{DD}$	4.6V
Inputs, $V_I$	-0.5V to $V_{DD} + 0.5V$
Input Termination Current, $I_{VT}$	$\pm 35mA$
Outputs, $I_O$ (LVDS) Continuous Current Surge Current	10mA 15mA
Storage Temperature, $T_{STG}$	-65°C to 150°C
Maximum Junction Temperature, $T_{JMAX}$	125°C
ESD - Human Body Model <sup>[a]</sup>	2000V
ESD - Charged Device Model <sup>[a]</sup>	500V

a. According to JEDEC/JS-001-2012/JESD22-C101E.

## DC Electrical Characteristics

Table 8: Power Supply DC Characteristics,  $V_{DD} = V_{DDO} = 2.5V \pm 5\%$ ,  $T_A = -40^\circ C$  to  $85^\circ C$

Symbol	Parameter	Test Conditions	Minimum	Typical	Maximum	Units
$V_{DD}$	Power Supply Voltage		2.375	2.5V	2.625	V
$V_{DDO}$	Output Supply Voltage		2.375	2.5V	2.625	V
$I_{DD}$	Power Supply Current			54	64	mA
$I_{DDO}$	Output Supply Current	All Outputs are Enabled and Terminated		155	182	mA

Table 9: LVCMOS/LVTTL Input DC Characteristics,  $V_{DD} = V_{DDO} = 2.5V \pm 5\%$ ,  $T_A = -40^{\circ}C$  to  $85^{\circ}C$ 

Symbol	Parameter		Test Conditions	Minimum	Typical	Maximum	Units
$V_{IH}$	Input High Voltage <sup>[a]</sup>	FSEL[1:0], ADR[1:0]		1.7		$V_{DD} + 0.3$	V
		SCL, SDA		1.9		$V_{DD} + 0.3$	V
$V_{IL}$	Input Low Voltage <sup>[a]</sup>	FSEL[1:0], ADR[1:0]		-0.3		0.7	V
		SCL, SDA		-0.3		0.5	V
$I_{IH}$	Input High Current	FSEL[1:0], ADR[1:0]	$V_{DD} = V_{IN} = 2.625$			150	$\mu A$
		SCL, SDA	$V_{DD} = V_{IN} = 2.625$			5	$\mu A$
$I_{IL}$	Input Low Current	FSEL[1:0], ADR[1:0]	$V_{DD} = 2.625, V_{IN} = 0V$	-10			$\mu A$
		SCL, SDA	$V_{DD} = 2.625, V_{IN} = 0V$	-150			$\mu A$

a.  $V_{IL}$  should not be lower than -0.3V and  $V_{IH}$  should not be higher than  $V_{DD} + 0.3V$ .

 Table 10: Differential Input DC Characteristics,  $V_{DD} = V_{DDO} = 2.5V \pm 5\%$ ,  $T_A = -40^{\circ}C$  to  $85^{\circ}C$ 

Symbol	Parameter		Test Conditions	Minimum	Typical	Maximum	Units
$V_{IN}$	Input Voltage Swing	IN, nIN		0.15		1.2	V
$V_{CMR}$	Common Mode Input Voltage <sup>[a], [b]</sup>			1.2		$V_{DD} - (V_{IN}/2)$	V
$V_{DIFF}$	Differential Input Voltage Swing	IN, nIN		0.3		2.4	V
$R_{IN}$	Input Resistance	IN, nIN to $V_T$		40	50	60	$\Omega$
$R_{IN}, D_{IFF}$	Differential Input Resistance	IN to nIN, $V_T = \text{open}$		80	100	120	$\Omega$

a. Common Mode Input Voltage is defined as the crosspoint.

b.  $V_{IL}$  should not be less than -0.3V and  $V_{IH}$  should not be greater than  $V_{DD}$ .

 Table 11: LVDS DC Characteristics,  $V_{DD} = V_{DDO} = 2.5V$ ,  $T_A = -40^{\circ}C$  to  $85^{\circ}C$ 

Symbol	Parameter	Test Conditions	Minimum	Typical	Maximum	Units
$V_{OD}$	Differential Output Voltage		247		454	mV
$\Delta V_{OD}$	$V_{OD}$ Magnitude Change				50	mV
$V_{OS}$	Offset Voltage		1.120		1.425	V
$\Delta V_{OS}$	$V_{OS}$ Magnitude Change				50	mV

## AC Electrical Characteristics

Table 12: AC Electrical Characteristics,  $V_{DD} = V_{DDO} = 2.5V \pm 5\%$ ,  $T_A = -40^\circ C$  to  $85^\circ C$  [a]

Symbol	Parameter		Test Conditions	Minimum	Typical	Maximum	Units
$f_{REF}$	Input Frequency	IN, nIN				1	GHz
$f_{SCL}$	I <sup>2</sup> C Clock Frequency					400	kHz
$t_{JIT}$	Buffer Additive Phase Jitter, RMS; refer to Additive Phase Jitter Section, measured with FSEL[1:0] = 00		$f_{REF} = 156.25MHz$ , Integration Range: 12kHz – 20MHz		96	120	fs
$t_{PD}$	Propagation Delay [b]	IN, nIN to Qx, nQx	FSEL[1:0] = 00	420		700	ps
			FSEL[1:0] = 01	580		880	ps
			FSEL[1:0] = 10	680		1080	ps
			FSEL[1:0] = 11	780		1180	ps
$t_{sk(o)}$	Output Skew [c], [d]				45	ps	
$t_{sk(p)}$	Pulse Skew		FSEL[1:0] = 00			55	ps
$t_{sk(pp)}$	Part-to-Part Skew [d], [e], [f]				200	ps	
odc	Output Duty Cycle [g]		FSEL[1:0] = 00		50		%
			FSEL[1:0] = 01	48	50	52	%
			FSEL[1:0] = 10	48	50	52	%
			FSEL[1:0] = 11	48	50	52	%
$t_{PDZ}$	Output Enable and Disable Time [h]		Output Enable/ Disable State from/ to Active/ Inactive		1		$\mu s$
$t_R / t_F$	Output Rise/ Fall Time		20% to 80%		155	230	ps
			10% to 90%		245	370	ps

- a. Electrical parameters are guaranteed over the specified ambient operating temperature range, which is established when the device is mounted in a test socket with maintained transverse airflow greater than 500 lpm. The device will meet specifications after thermal equilibrium has been reached under these conditions.
- b. Measured from the differential input crosspoint to the differential output crosspoint.
- c. Defined as skew between outputs at the same supply voltage and with equal load conditions. Measured at the differential crosspoint.
- d. This parameter is defined in accordance with JEDEC Standard 65.
- e. Defined as skew between outputs on different devices operating at the same supply voltage, same temperature, same frequency and with equal load conditions. Using the same type of inputs on each device, the outputs are measured at the differential crosspoint.
- f. Part-to-part skew specification does not guarantee divider synchronization among devices.
- g. If FSEL[1:0] = 00 (divide-by-one), the output duty cycle will depend on the input duty cycle.
- h. Measured from SDA rising edge of I<sup>2</sup>C stop command.



## Additive Phase Jitter

The spectral purity in a band at a specific offset from the fundamental compared to the power of the fundamental is called the **dBc Phase Noise**. This value is normally expressed using a Phase noise plot and is most often the specified plot in many applications. Phase noise is defined as the ratio of the noise power present in a 1Hz band at a specified offset from the fundamental frequency to the power value of the fundamental. This ratio is expressed in decibels (dBm) or a ratio of the power in the 1Hz band to the power in the fundamental. When the required offset is specified, the phase noise is called a **dBc** value, which simply means dBm at a specified offset from the fundamental. By investigating jitter in the frequency domain, we get a better understanding of its effects on the desired application over the entire time record of the signal. It is mathematically possible to calculate an expected bit error rate given a phase noise plot.

### Typical Phase Jitter at 156.25MHz

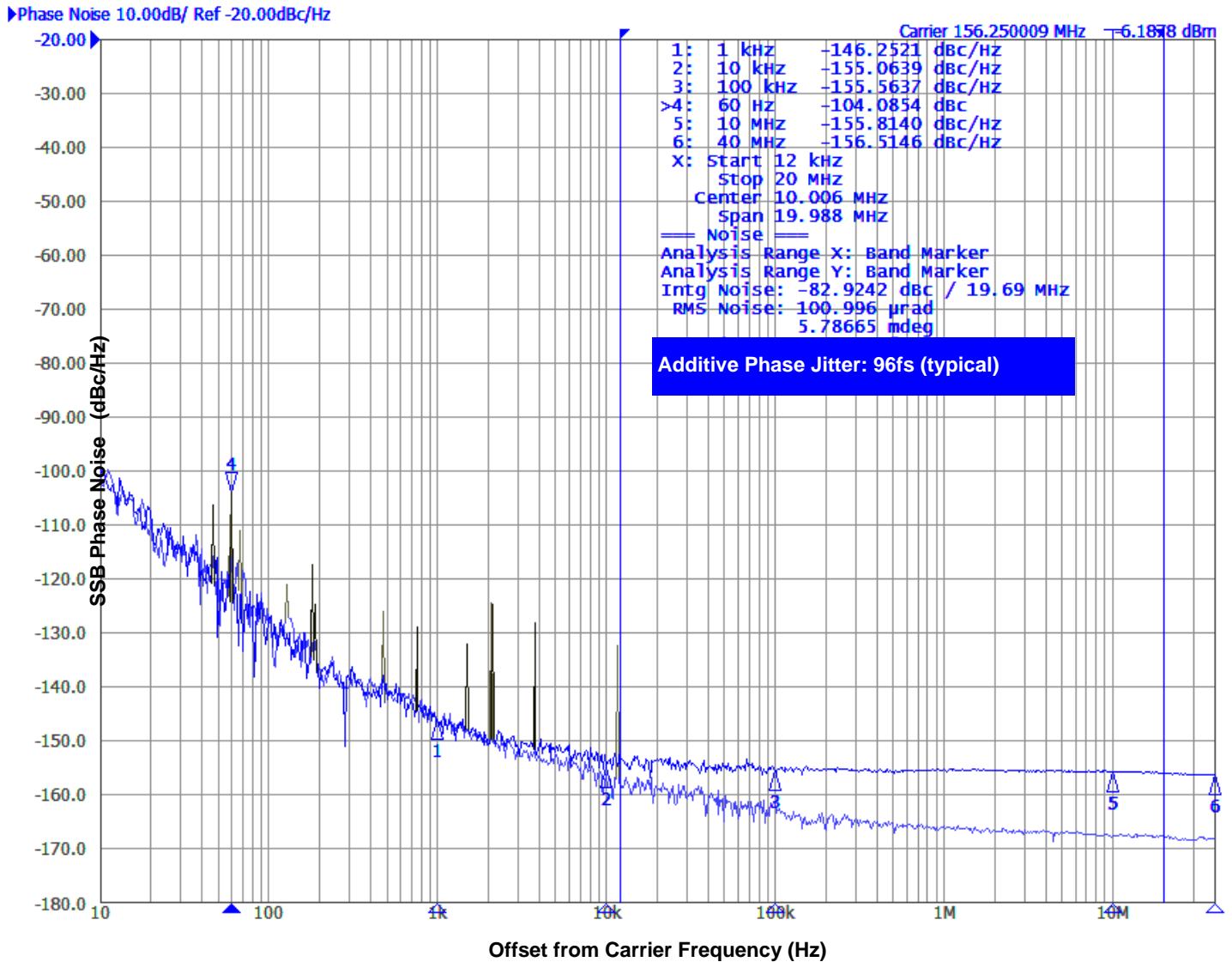

The input source is 156.25MHz Wenzel Oscillator.

Parameter Measurement Information

Figure 6: LVDS Output Load AC Test Circuit

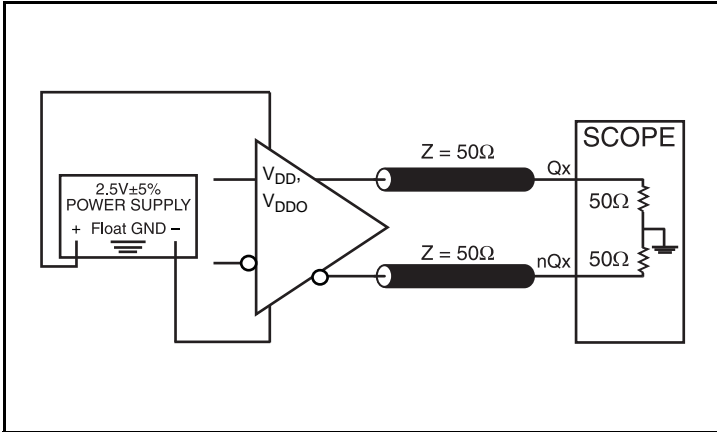

Figure 9: Differential Input Level

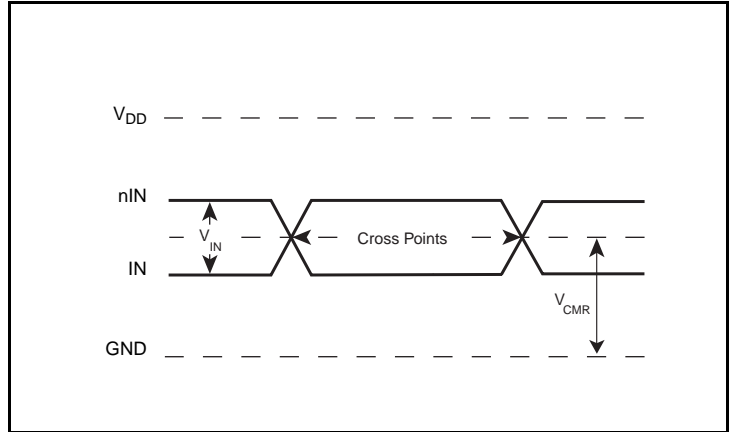

Figure 7: Output Skew

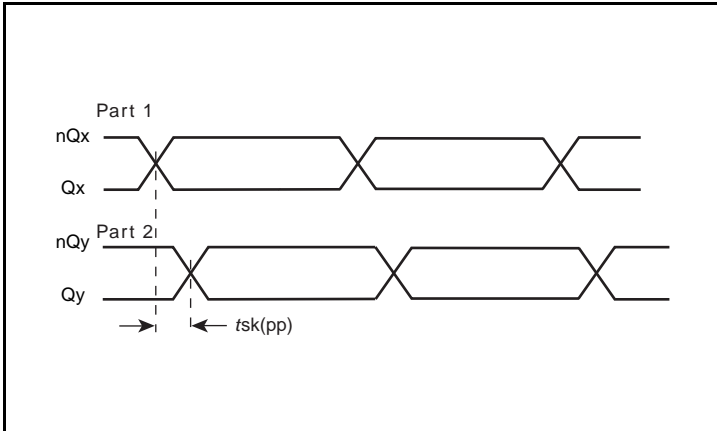

Figure 10: Output Skew

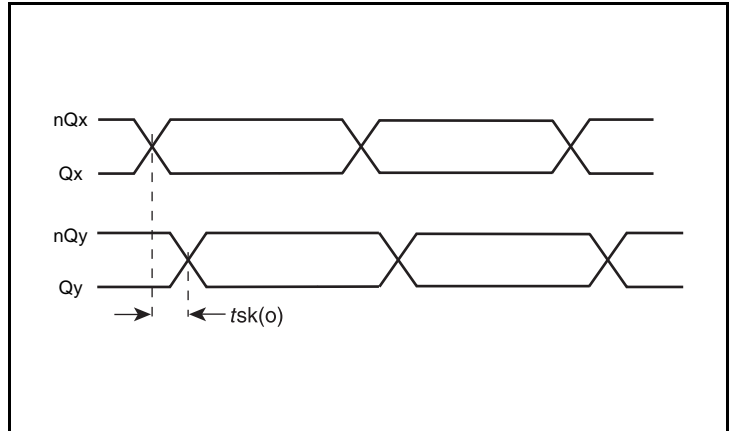

Figure 8: Pulse Skew

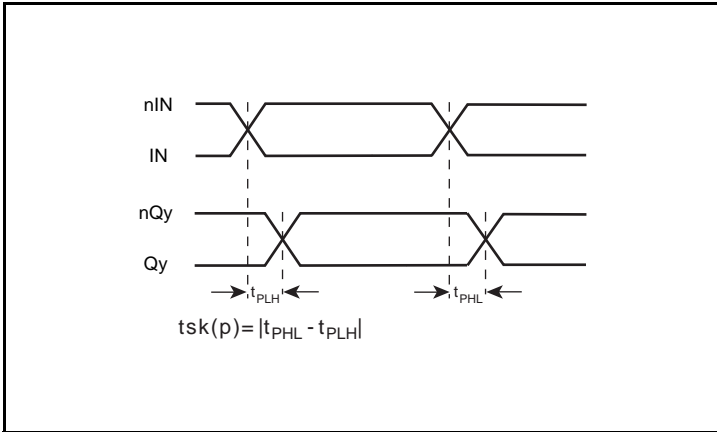
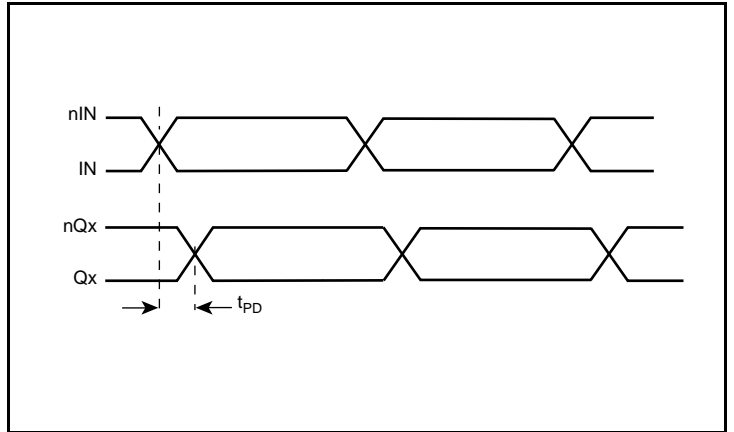

Figure 11: Propagation Delay



Parameter Measurement Information, continued

Figure 12: Output Rise/Fall Time

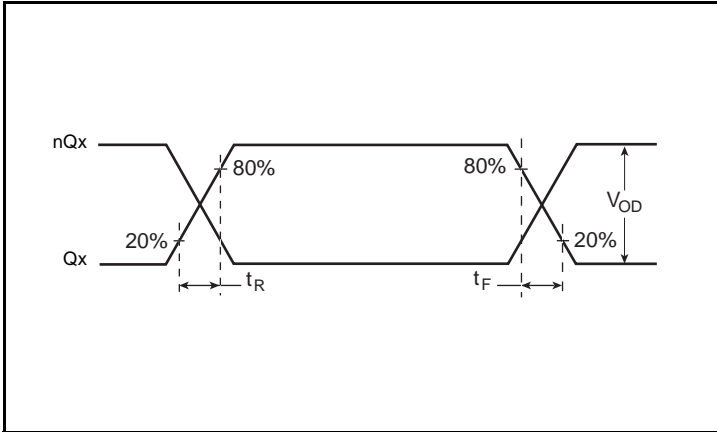

Figure 15: Output Rise/Fall Time

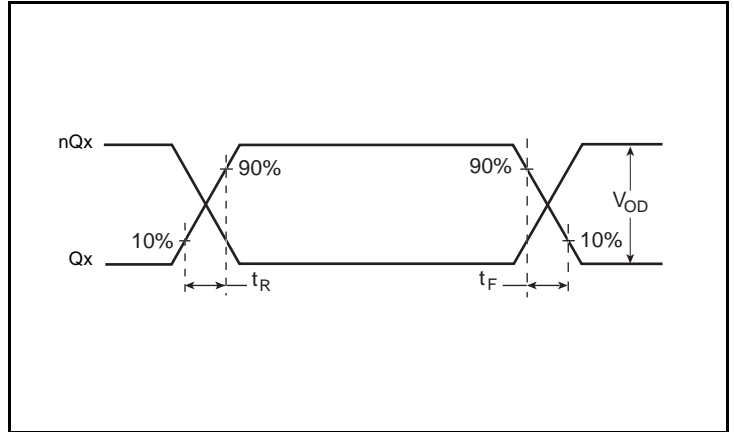

Figure 13: Single-Ended & Differential Input Voltage Swing

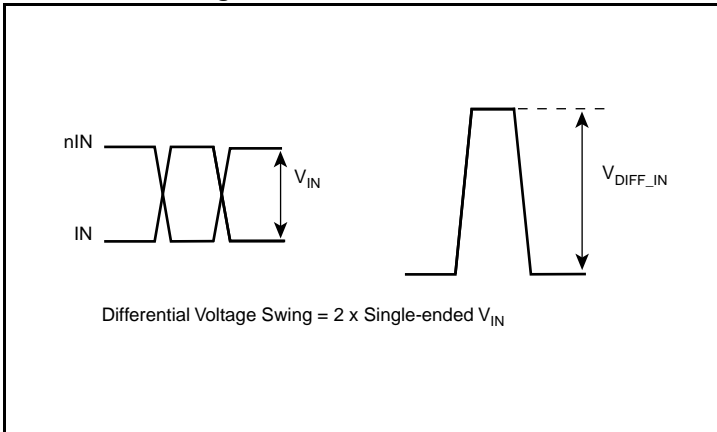

Figure 16: Output Duty Cycle/Pulse Width/Period

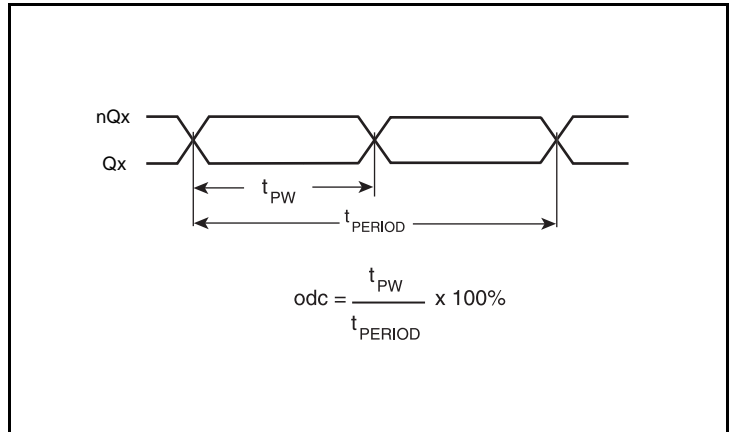

Figure 14: Offset Voltage Setup

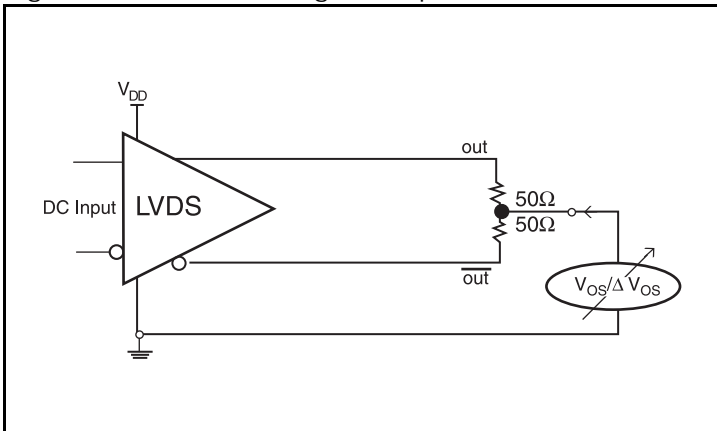
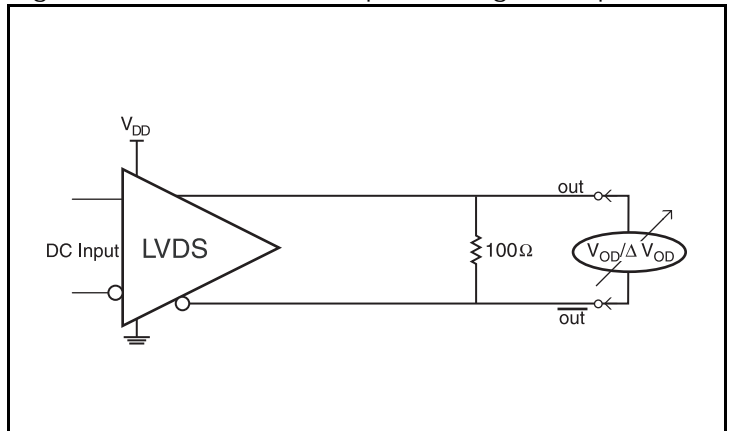

Figure 17: Differential Output Voltage Setup



## Applications Information

### Differential Input with Built-In 50Ω Termination Interface

The IN/nIN with built-in 50Ω terminations accept LVDS, LVPECL, CML and other differential signals. Both differential signals must meet the  $V_{IN}$  and  $V_{CMR}$  requirements. [Figure 18](#) to [Figure 20](#) to show interface examples for the IN/nIN input with built-in 50Ω terminations driven by the most common driver types. The input interfaces suggested here are examples only. If the driver is from another vendor, use their termination recommendation. Please consult with the vendor of the driver component to confirm the driver termination requirements.

Figure 18: IN/nIN Input with Built-In 50Ω driven by an LVDS Driver

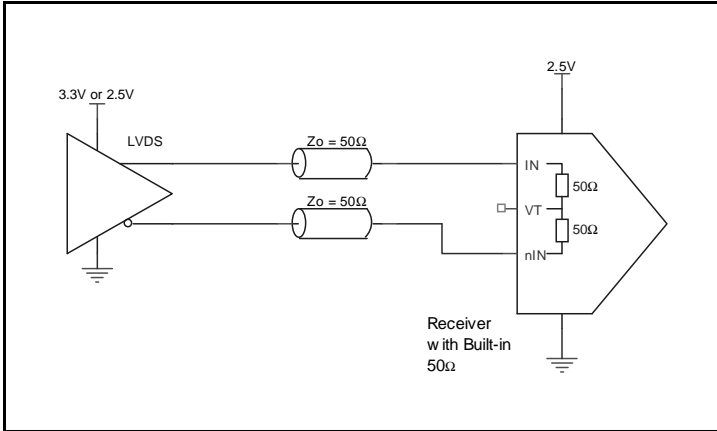

Figure 20: IN/nIN Input with Built-In 50Ω driven by an LVPECL Driver

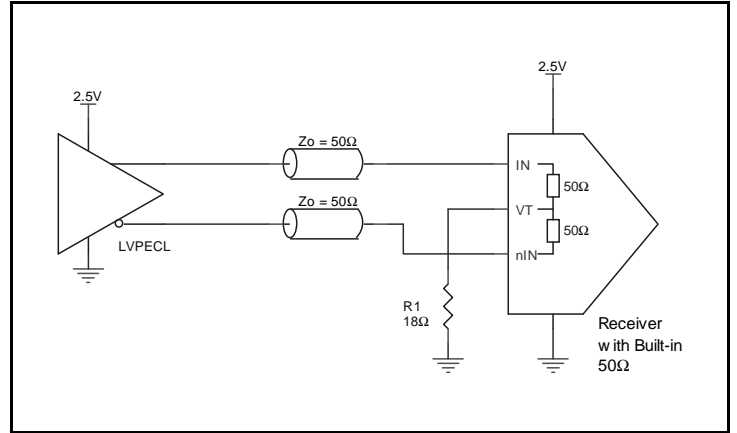
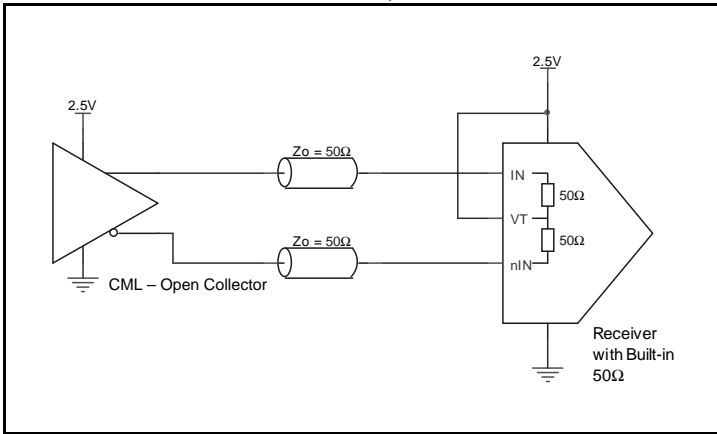

Figure 19: IN/nIN Input with Built-In 50Ω Driven by a CML Driver with Open Collector



## VFQFN EPAD Thermal Release Path

In order to maximize both the removal of heat from the package and the electrical performance, a land pattern must be incorporated on the Printed Circuit Board (PCB) within the footprint of the package corresponding to the exposed metal pad or exposed heat slug on the package, as shown in [Figure 21](#). The solderable area on the PCB, as defined by the solder mask, should be at least the same size/shape as the exposed pad/slug area on the package to maximize the thermal/electrical performance. Sufficient clearance should be designed on the PCB between the outer edges of the land pattern and the inner edges of pad pattern for the leads to avoid any shorts.

While the land pattern on the PCB provides a means of heat transfer and electrical grounding from the package to the board through a solder joint, thermal vias are necessary to effectively conduct from the surface of the PCB to the ground plane(s). The land pattern must be connected to ground through these vias. The vias act as “heat pipes”. The number of vias (i.e. “heat pipes”) are application specific and dependent upon the package power dissipation as well as electrical conductivity requirements. Thus, thermal and electrical analysis and/or testing are recommended to determine the minimum number needed. Maximum thermal and electrical performance is achieved when an array of vias is incorporated in the land pattern. It is recommended to use as many vias connected to ground as possible. It is also recommended that the via diameter should be 12 to 13mils (0.30 to 0.33mm) with 1oz copper via barrel plating. This is desirable to avoid any solder wicking inside the via during the soldering process which may result in voids in solder between the exposed pad/slug and the thermal land. Precautions should be taken to eliminate any solder voids between the exposed heat slug and the land pattern. Note: These recommendations are to be used as a guideline only. For further information, please refer to the Application Note on the Surface Mount Assembly of Amkor’s Thermally/ Electrically Enhance Lead frame Base Package, Amkor Technology.

Figure 21: P.C. Assembly for Exposed Pad Thermal Release Path – Side View (drawing not to scale)

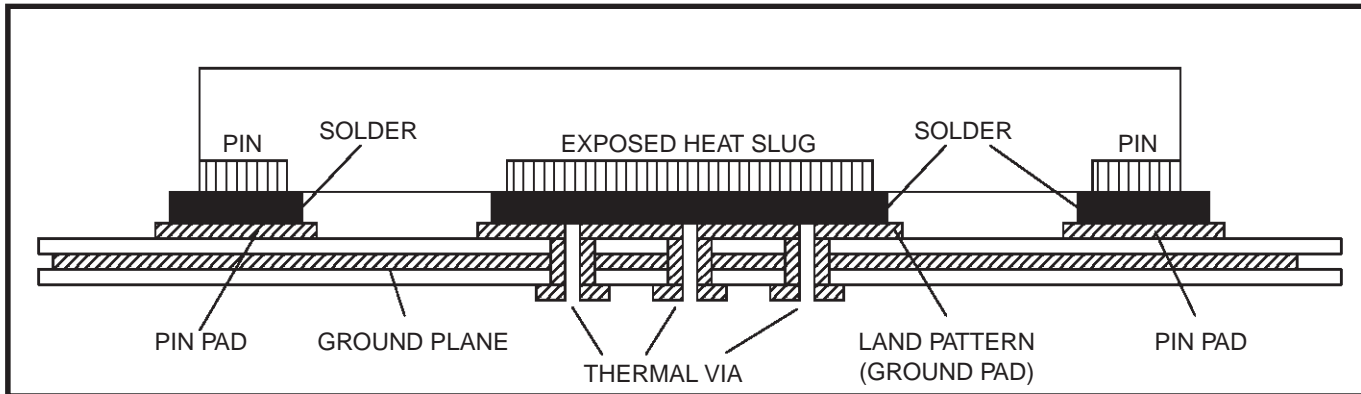

## Recommendations for Unused Input and Output Pins

### Inputs:

#### LVCMOS Control Pins

All control pins have internal pullup or pulldown resistors; additional resistance is not required but can be added for additional protection. A 1k $\Omega$  resistor can be used.

### Outputs:

#### LVDS Outputs

All unused LVDS output pairs can be either left floating or terminated with 100 $\Omega$  across. If they are left floating, there should be no trace attached.

## LVDS Driver Termination

For a general LVDS interface, the recommended value for the termination impedance ( $Z_T$ ) is between  $90\Omega$  and  $132\Omega$ . The actual value should be selected to match the differential impedance ( $Z_0$ ) of your transmission line. A typical point-to-point LVDS design uses a  $100\Omega$  parallel resistor at the receiver and a  $100\Omega$  differential transmission-line environment. In order to avoid any transmission-line reflection issues, the components should be surface mounted and must be placed as close to the receiver as possible. IDT offers a full line of LVDS compliant devices with two types of output structures: current source and voltage source. The standard termination schematic as shown in [Figure 22](#) can be used with either type of output structure. [Figure 23](#), which can also be used with both output types, is an optional termination with center tap capacitance to help filter common mode noise. The capacitor value should be approximately  $50\text{pF}$ . If using a non-standard termination, it is recommended to contact IDT and confirm if the output structure is current source or voltage source type. In addition, since these outputs are LVDS compatible, the input receiver's amplitude and common-mode input range should be verified for compatibility with the output.

Figure 22: Standard LVDS Termination

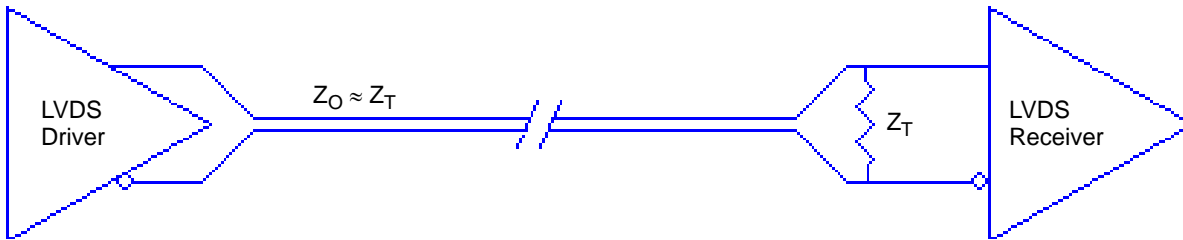
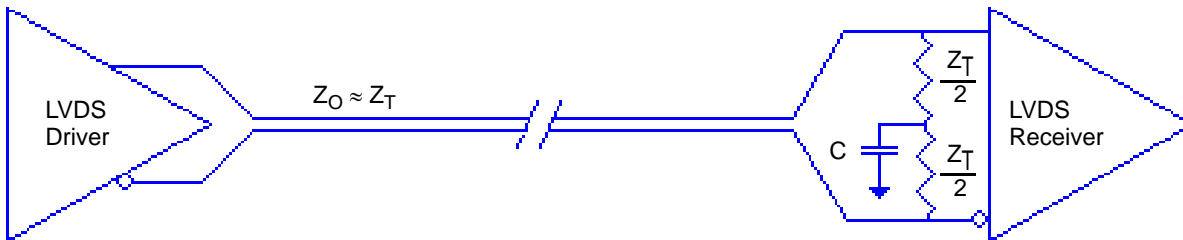

Figure 23: Optional LVDS Termination



## Power Considerations

### 1. Power Dissipation.

The total power dissipation for the 8T74S208B is the sum of the core power plus the power dissipated due to the load. The following is the power dissipation for  $V_{DD} = 2.5V + 5\% = 2.625V$ , which gives worst case results.

- Power (core)<sub>MAX</sub> =  $V_{DD\_MAX} * I_{DD\_MAX} = 2.625V * 57.7mA = \mathbf{151.46mW}$
- Power (output)<sub>MAX</sub> =  $V_{DDO\_MAX} * I_{DDO} = 2.625V * 164.5mA = \mathbf{431.81mW}$
- Power Dissipation for internal termination  $R_T$   
Power (R<sub>T</sub>)<sub>MAX</sub> =  $(V_{IN\_MAX})^2 / R_{T\_MIN} = (1.2)^2 / 80 = \mathbf{18mW}$

**Total Power**<sub>MAX</sub> = (3.465V, with all outputs switching) = 151.46mW + 431.81mW + 18mW = **601.27mW**

### 2. Junction Temperature.

Junction temperature,  $T_j$ , is the temperature at the junction of the bond wire and bond pad directly affects the reliability of the device. The maximum recommended junction temperature is 125°C. Limiting the internal transistor junction temperature,  $T_j$ , to 125°C ensures that the bond wire and bond pad temperature remains below 125°C.

The equation for  $T_j$  is as follows:  $T_j = \theta_{JA} * Pd\_total + T_A$

$T_j$  = Junction Temperature

$\theta_{JA}$  = Junction-to-Ambient Thermal Resistance

$Pd\_total$  = Total Device Power Dissipation (example calculation is in section 1 above)

$T_A$  = Ambient Temperature

In order to calculate junction temperature, the appropriate junction-to-ambient thermal resistance  $\theta_{JA}$  must be used. Assuming no air flow and a multi-layer board, the appropriate value is 42.7°C/W per [Table 13](#) below.

Therefore,  $T_j$  for an ambient temperature of 85°C with all outputs switching is:

$$85^\circ\text{C} + 0.601\text{W} * 42.7^\circ\text{C/W} = 111^\circ\text{C}. \text{ This is below the limit of } 125^\circ\text{C}.$$

This calculation is only an example.  $T_j$  will obviously vary depending on the number of loaded outputs, supply voltage, air flow and the type of board (multi-layer).

Table 13: Thermal Resistance  $\theta_{JA}$  for 32-Lead VFQFN, Forced Convection

$\theta_{JA}$ by Velocity			
Meters per Second	0	1	2.5
Multi-Layer PCB, JEDEC Standard Test Boards	42.7°C/W	37.3°C/W	33.5°C/W

## Reliability Information

Table 14:  $\theta_{JA}$  vs. Air Flow Table for a 32-Lead VFQFN

$\theta_{JA}$ by Velocity			
Meters per Second	0	1	2.5
Multi-Layer PCB, JEDEC Standard Test Boards	42.7°C/W	37.3°C/W	33.5°C/W

## Transistor Count

The transistor count for 8T74S208B is: 4969



# 32-Lead VFQFN Package Outline and Package Dimensions

REVISIONS			
REV	DESCRIPTION	DATE	APPROVED
00	INITIAL RELEASE	2/1/16	JH
01	ADD "k" VALUE MIN 0.20	2/8/16	JH

SYMBOL	DIMENSION		
	MIN	NOM	MAX
b	0.18	0.25	0.30
D	5.00 BSC		
E	5.00 BSC		
D2	3.00	3.15	3.30
E2	3.00	3.15	3.30
L	0.30	0.40	0.50
e	0.50 BSC		
N	32		
A	0.80	0.90	1.00
A1	0.00	0.02	0.05
A3	0.2 REF		
k	0.20 10:53 REF		

TOP VIEW

SIDE VIEW

BOTTOM VIEW

PIN #1 ID OPTION

NOTES:

- ALL DIMENSIONS ARE IN mm. ANGLES IN DEGREES.
- COPLANARITY APPLIES TO THE EXPOSED PAD AS WELL AS THE TERMINALS.  
COPLANARITY SHALL NOT EXCEED 0.08 mm.
- WARPAGE SHALL NOT EXCEED 0.10 mm.

TOLERANCES UNLESS SPECIFIED DECIMAL ±1 XX±.05 XXX±.050		6024 Silver Creek Valley Rd San Jose, CA 95138 PHONE: (408) 284-8200 FAX: (408) 284-3572 www.IDT.com
APPROVALS	DATE	TITLE
DRAWN $\phi$ AC	2/1/16	NL/NLG 32 PACKAGE OUTLINE
CHECKED		5.0 x 5.0 mm BODY EPAD 3.15 x 3.15
		0.50 mm PITCH QFN
SIZE	DRAWING No.	REV
C	PSC-4171-01	01
DO NOT SCALE DRAWING		SHEET 1 OF 2

# 32-Lead VFQFN Package Outline and Package Dimensions

REVISIONS			
REV	DESCRIPTION	DATE	APPROVED
00	INITIAL RELEASE	2/1/16	JH
01	ADD "k" VALUE MIN 0.20	2/8/16	JH

RECOMMENDED LAND PATTERN

**NOTES:**

1. ALL DIMENSIONS ARE IN mm. ANGLES IN DEGREES.
2. TOP DOWN VIEW, AS VIEWED ON PCB.
3. COMPONENT OUTLINE SHOWS FOR REFERENCE IN GREEN.
4. LAND PATTERN IN BLUE. NSMD PATTERN ASSUMED.
5. LAND PATTERN RECOMMENDATION PER IPC-7351B GENERIC REQUIREMENT FOR SURFACE MOUNT DESIGN AND LAND PATTERN.

<b>TOLERANCES UNLESS SPECIFIED</b> DECIMAL XX± .05 XXX± .030	<b>APPROVALS</b> DRAWN <i>6AC</i> CHECKED	<b>DATE</b> 2/1/16	6024 Silver Creek Valley Rd San Jose, CA 95138 PHONE: (408) 284-8200 FAX: (408) 284-3572 www.IDT.com
<b>IDT™</b>		<b>TITLE</b> NL/NLG 32 PACKAGE OUTLINE 5.0 x 5.0 mm BODY EPAD 3.15 x 3.15 0.50 mm PITCH QFN	
SIZE C DRAWING No. PSC-4171-01		REV 01	
DO NOT SCALE DRAWING		SHEET 2 OF 2	

## Ordering Information

Part/Order Number	Marking	Package	Shipping Packaging	Temperature
8T74S208BNLGI	IDT8T74S208BNLGI	32-Lead VFQFN, Lead-Free	Tray	-40°C to 85°C
8T74S208BNLGI8	IDT8T74S208BNLGI	32-Lead VFQFN, Lead-Free	Tape & Reel	-40°C to 85°C

## Marking Diagram

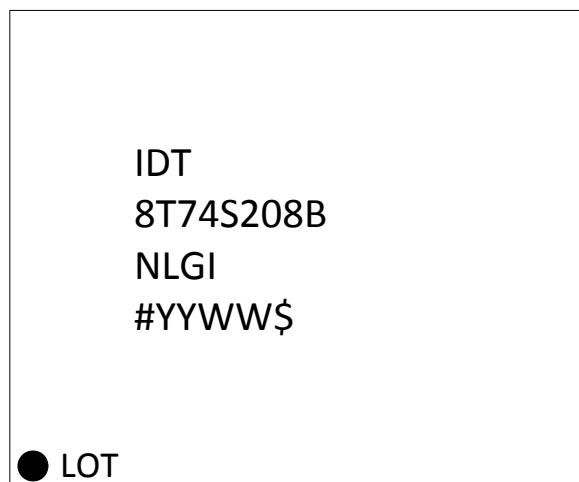

## Datasheet Revision History

Revision Date	Description of Change
August 10, 2016	Initial final release.

## Silicon Revision History

Silicon Revision	Description of Change
Revision B: 8T74S208ANLGI to 8T74S208BNLGI	<ul style="list-style-type: none"> <li>▪ Datasheet part number updated from 8T74S208A to 8T74S208B.</li> <li>▪ Power Supply DC Characteristics Table:               <ul style="list-style-type: none"> <li>– <math>I_{DD}</math> typical parameter from 41mA to 54mA, maximum from 49mA to 64mA.</li> <li>– <math>I_{DDO}</math> typical parameter from 153mA to 155mA, maximum from 176mA to 184mA.</li> </ul> </li> <li>▪ Differential Input DC Characteristics Table:               <ul style="list-style-type: none"> <li>– <math>V_{CMR}</math> maximum parameter from <math>V_{DD} - (V_{PP}/2)</math> to maximum <math>V_{DD} - (V_{IN}/2)</math>.</li> </ul> </li> <li>▪ AC Characteristics Table:               <ul style="list-style-type: none"> <li>– <math>t_{PD}</math>:                   <ul style="list-style-type: none"> <li>(FSEL[1:0] = 00 row), maximum parameter from 620ps to 700ps.</li> <li>(FSEL[1:0] = 01 row), maximum parameter from 800ps to 880ps.</li> <li>(FSEL[1:0] = 10 row), maximum parameter from 920ps to 1080ps.</li> <li>(FSEL[1:0] = 11 row), maximum parameter from 1050ps to 1180ps.</li> </ul> </li> <li>– <math>t_R / t_F</math> maximum parameter from 350ps to 370ps.</li> </ul> </li> <li>▪ The Power Considerations section has been updated to reflect the changes in the Power Supply DC Characteristics Table.</li> </ul>



## IMPORTANT NOTICE AND DISCLAIMER

RENESAS ELECTRONICS CORPORATION AND ITS SUBSIDIARIES (“RENESAS”) PROVIDES TECHNICAL SPECIFICATIONS AND RELIABILITY DATA (INCLUDING DATASHEETS), DESIGN RESOURCES (INCLUDING REFERENCE DESIGNS), APPLICATION OR OTHER DESIGN ADVICE, WEB TOOLS, SAFETY INFORMATION, AND OTHER RESOURCES “AS IS” AND WITH ALL FAULTS, AND DISCLAIMS ALL WARRANTIES, EXPRESS OR IMPLIED, INCLUDING, WITHOUT LIMITATION, ANY IMPLIED WARRANTIES OF MERCHANTABILITY, FITNESS FOR A PARTICULAR PURPOSE, OR NON-INFRINGEMENT OF THIRD-PARTY INTELLECTUAL PROPERTY RIGHTS.

These resources are intended for developers who are designing with Renesas products. You are solely responsible for (1) selecting the appropriate products for your application, (2) designing, validating, and testing your application, and (3) ensuring your application meets applicable standards, and any other safety, security, or other requirements. These resources are subject to change without notice. Renesas grants you permission to use these resources only to develop an application that uses Renesas products. Other reproduction or use of these resources is strictly prohibited. No license is granted to any other Renesas intellectual property or to any third-party intellectual property. Renesas disclaims responsibility for, and you will fully indemnify Renesas and its representatives against, any claims, damages, costs, losses, or liabilities arising from your use of these resources. Renesas' products are provided only subject to Renesas' Terms and Conditions of Sale or other applicable terms agreed to in writing. No use of any Renesas resources expands or otherwise alters any applicable warranties or warranty disclaimers for these products.

(Disclaimer Rev.1.01 Jan 2024)

### Corporate Headquarters

TOYOSU FORESIA, 3-2-24 Toyosu,  
Koto-ku, Tokyo 135-0061, Japan  
[www.renesas.com](http://www.renesas.com)

### Trademarks

Renesas and the Renesas logo are trademarks of Renesas Electronics Corporation. All trademarks and registered trademarks are the property of their respective owners.

### Contact Information

For further information on a product, technology, the most up-to-date version of a document, or your nearest sales office, please visit [www.renesas.com/contact-us/](http://www.renesas.com/contact-us/).