

Description

The 8SLVS1118 is a high-performance, low-power, differential 1:18 output fanout buffer. This highly versatile device is designed for the fanout of high-frequency, very low additive phase-noise clock and data signals. Guaranteed output-to-output and part-to-part skew characteristics make the 8SLVS1118 ideal for clock distribution applications that demand well-defined performance and repeatability.

The device is characterized to operate from a 2.5V or 3.3V power supply. The integrated bias voltage references enable easy interfacing AC-coupled signals to the device inputs.

Features

- 1:18, low skew, low additive jitter LVPECL/LVDS fanout buffer
- Low power consumption
- Differential PCLK, nPCLK clock pair accepts the following differential/single-ended input levels: LVDS, LVPECL, and LVCMOS
- Maximum input clock frequency: 2GHz
- Propagation delay: 290ps (typical)
- Output skew: 40ps (typical)
- Low additive phase jitter, RMS: 39fs (typical), Integration Range: 12kHz – 20MHz, ($f_{REF} = 156.25\text{MHz}$, $V_{PP} = 1\text{V}$, $V_{DD} = 3.3\text{V}$)
- Full 2.5V and 3.3V supply voltage modes
- Device current consumption: 180mA (typical) IEE for LVPECL output mode, 400mA (typical) IDD for LVDS output mode
- 48-VFQFPN, lead-free (RoHS 6) packaging
- Transistor count: 1762
- -40°C to +85°C ambient operating temperature
- Supports case temperature up to 105°C

Block Diagram

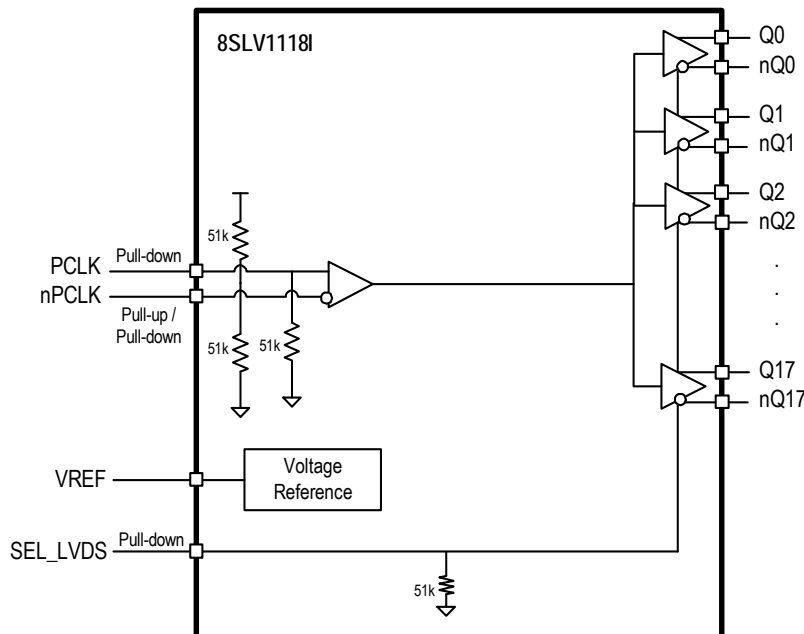

Pin Assignment

Figure 1. Pin Assignment for 7mm × 7mm VFQFPN Package – Top View

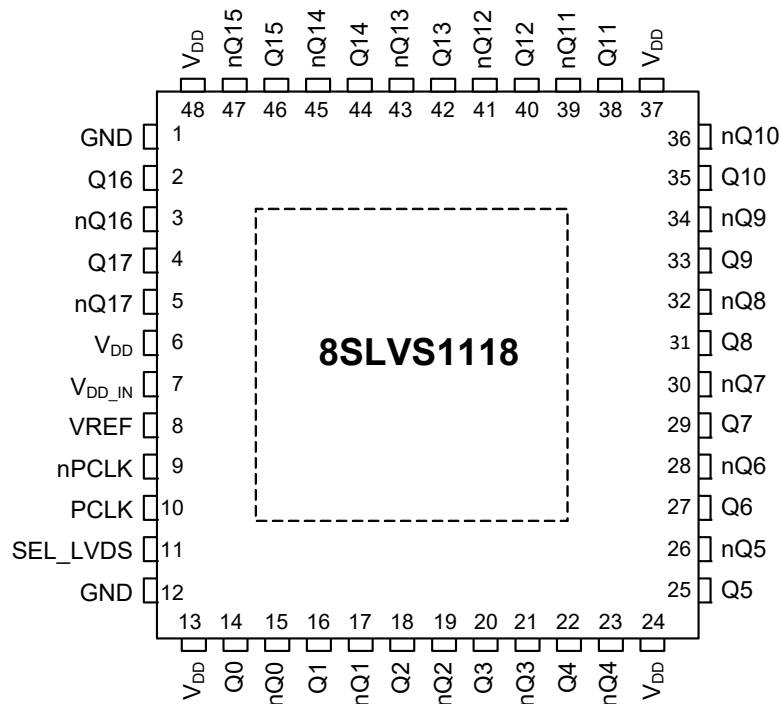

Pin Descriptions

Table 1. Pin Descriptions^[a]

Number	Name	Type	Description
1	GND	Power	Ground supply pin.
2	Q16	Output	Differential output pair. LVPECL/ LVDS interface levels.
3	nQ16	Output	Differential output pair. LVPECL/ LVDS interface levels.
4	Q17	Output	Differential output pair. LVPECL/ LVDS interface levels.
5	nQ17	Output	Differential output pair. LVPECL/ LVDS interface levels.
6	V _{DD}	Power	Output power supply pin.
7	V _{DD_IN}	Power	Power supply pin.
8	VREF	Output	Bias voltage reference for the PCLK, nPCLK input pair.
9	nPCLK	Input [PD/PU]	Inverting differential clock/data input.
10	PCLK	Input [PD]	Non-inverting differential clock/data input.
11	SEL_LVDS	Input [PD]	Control input. Output amplitude select for differential outputs.
12	GND	Power	Power supply ground.
13	V _{DD}	Power	Output power supply pin.
14	Q0	Output	Differential output pair. LVPECL/ LVDS interface levels.
15	nQ0	Output	Differential output pair. LVPECL/ LVDS interface levels.
16	Q1	Output	Differential output pair. LVPECL/ LVDS interface levels.

Table 1. Pin Descriptions^[a] (Cont.)

Number	Name	Type	Description
17	nQ1	Output	Differential output pair. LVPECL/ LVDS interface levels.
18	Q2	Output	Differential output pair. LVPECL/ LVDS interface levels.
19	nQ2	Output	Differential output pair. LVPECL/ LVDS interface levels.
20	Q3	Output	Differential output pair. LVPECL/ LVDS interface levels.
21	nQ3	Output	Differential output pair. LVPECL/ LVDS interface levels.
22	Q4	Output	Differential output pair. LVPECL/ LVDS interface levels.
23	nQ4	Output	Differential output pair. LVPECL/ LVDS interface levels.
24	V _{DD}	Power	Output power supply pin.
25	Q5	Output	Differential output pair. LVPECL/ LVDS interface levels.
26	nQ5	Output	Differential output pair. LVPECL/ LVDS interface levels.
27	Q6	Output	Differential output pair. LVPECL/ LVDS interface levels.
28	nQ6	Output	Differential output pair. LVPECL/ LVDS interface levels.
29	Q7	Output	Differential output pair. LVPECL/ LVDS interface levels.
30	nQ7	Output	Differential output pair. LVPECL/ LVDS interface levels.
31	Q8	Output	Differential output pair. LVPECL/ LVDS interface levels.
32	nQ8	Output	Differential output pair. LVPECL/ LVDS interface levels.
33	Q9	Output	Differential output pair. LVPECL/ LVDS interface levels.
34	nQ9	Output	Differential output pair. LVPECL/ LVDS interface levels.
35	Q10	Output	Differential output pair. LVPECL/ LVDS interface levels.
36	nQ10	Output	Differential output pair. LVPECL/ LVDS interface levels.
37	V _{DD}	Power	Output power supply pin.
38	Q11	Output	Differential output pair. LVPECL/ LVDS interface levels.
39	nQ11	Output	Differential output pair. LVPECL/ LVDS interface levels.
40	Q12	Output	Differential output pair. LVPECL/ LVDS interface levels.
41	nQ12	Output	Differential output pair. LVPECL/ LVDS interface levels.
42	Q13	Output	Differential output pair. LVPECL/ LVDS interface levels.
43	nQ13	Output	Differential output pair. LVPECL/ LVDS interface levels.
44	Q14	Output	Differential output pair. LVPECL/ LVDS interface levels.
45	nQ14	Output	Differential output pair. LVPECL/ LVDS interface levels.
46	Q15	Output	Differential output pair. LVPECL/ LVDS interface levels.
47	nQ15	Output	Differential output pair. LVPECL/ LVDS interface levels.
48	V _{DD}	Power	Output power supply pin.
ePad	GND_EPAD	Power	Exposed pad of package. Connect to ground.

[a] Pull-up (PU) and pull-down (PD) resistors are indicated in parentheses. *Pull-up* and *pull-down* refers to internal input resistors. For typical values, see [DC Input Characteristics](#).

Function Table

Table 2. SEL_LVDS Output Amplitude Selection Table

SEL_LVDS	Qx Output Amplitude (mV)
0 (default)	750 (LVPECL)
1	450 (LVDS)

Absolute Maximum Ratings

The absolute maximum ratings are stress ratings only. Stresses greater than those listed below can cause permanent damage to the device. Functional operation of the 8SLVS1118 at absolute maximum ratings is not implied. Exposure to absolute maximum rating conditions may affect device reliability.

Table 3. Absolute Maximum Ratings

Item	Rating
Supply Voltage, V_{DD_IN}	3.6V
Inputs, V_I	-0.5V to 3.6V
Outputs, I_O (LVDS) Continuous Current Surge current	10mA 15mA
Outputs, I_O (LVPECL) Continuous Current Surge current	50mA 100mA
Input Sink/source, I_{REF}	± 2 mA
Maximum Junction Temperature, $T_{J,MAX}$	125°C
Storage Temperature, T_{STG}	-65°C to 150°C
ESD – Human Body Model ^[a]	2000V
ESD – Charged Device Model ^[a]	1500V

[a] According to JEDEC JS-001-2012/JESD22-C101E.

DC Electrical Characteristics

Table 4. DC Input Characteristics

Symbol	Parameter	Test Conditions	Minimum	Typical	Maximum	Units
C_{IN}	Input Capacitance			2		pF
$R_{PULLDOWN}$	Input Pull-down Resistor			51		k Ω
R_{PULLUP}	Input Pull-up Resistor			51		k Ω

Table 5. Power Supply DC Characteristics, $V_{DD_IN} = V_{DD} = 3.3V \pm 5\%$, $T_A = -40^\circ C$ to $+85^\circ C$

Symbol	Parameter	Test Conditions	Minimum	Typical	Maximum	Units
V_{DD_IN}	Power Supply Voltage		3.135	3.3	3.465	V
V_{DD}	Output Supply Voltage		3.135	3.3	3.465	V
I_{DD_IN}	Power Supply Current				15	mA
I_{EE}	Power Supply Current	SEL_LVDS = 0			220	mA
I_{DD}	Output Supply Current	SEL_LVDS = 1			480	mA

Table 6. Power Supply DC Characteristics, $V_{DD_IN} = V_{DD} = 2.5V \pm 5\%$, $T_A = -40^\circ C$ to $+85^\circ C$

Symbol	Parameter	Test Conditions	Minimum	Typical	Maximum	Units
V_{DD_IN}	Power Supply Voltage		2.375	2.5	2.625	V
V_{DD}	Output Supply Voltage		2.375	2.5	2.625	V
I_{DD_IN}	Power Supply Current				13	mA
I_{EE}	Power Supply Current	SEL_LVDS = 0			215	mA
I_{DD}	Output Supply Current	SEL_LVDS = 1			475	mA

Table 7. LVCMOS Inputs DC Characteristics, $V_{DD_IN} = V_{DD} = 2.5V \pm 5\%$, $3.3V \pm 5\%$, $T_A = -40^\circ C$ to $+85^\circ C$

Symbol	Parameter	Test Conditions	Minimum	Typical	Maximum	Units
V_{IH}	Input High Voltage	$V_{DD_IN} = 3.3V \pm 5\%$	2		$V_{DD_IN} + 0.3$	V
		$V_{DD_IN} = 2.5V \pm 5\%$	1.7		$V_{DD_IN} + 0.3$	V
V_{IL}	Input Low Voltage	$V_{DD_IN} = 3.3V \pm 5\%$	-0.3		0.8	V
		$V_{DD_IN} = 2.5V \pm 5\%$	-0.3		0.7	V
I_{IH}	Input High Current	SEL_LVDS $V_{DD_IN} = V_{IN} = V_{DD_MAX}$			150	μA
I_{IL}	Input Low Current	SEL_LVDS $V_{DD_IN} = V_{DD_MAX}, V_{IN} = 0V$	-10			μA

Table 8. LVDS DC Characteristics - $V_{DD} = 3.3V \pm 5\%$, $T_A = -40^\circ C$ to $+85^\circ C$

Symbol	Parameter	Test Conditions	Minimum	Typical	Maximum	Units
V_{OD}	Differential Output Voltage		370		490	mV
ΔV_{OD}	V_{OD} Magnitude Change				50	mV
V_{OS}	Offset Voltage		1.9		2.7	V
ΔV_{OS}	V_{OS} Magnitude Change				50	mV

 Table 9. LVDS DC Characteristics - $V_{DD} = 2.5V \pm 5\%$, $T_A = -40^\circ C$ to $+85^\circ C$

Symbol	Parameter	Test Conditions	Minimum	Typical	Maximum	Units
V_{OD}	Differential Output Voltage		360		480	mV
ΔV_{OD}	V_{OD} Magnitude Change				50	mV
V_{OS}	Offset Voltage		1.1		1.9	V
ΔV_{OS}	V_{OS} Magnitude Change				50	mV

 Table 10. LVPECL DC Characteristics, $V_{DD_IN} = V_{DD} = 2.5V \pm 5\%$, $3.3V \pm 5\%$, $T_A = -40^\circ C$ to $+85^\circ C$ ^[a]

Symbol	Parameter	Test Conditions	Minimum	Typical	Maximum	Units
I_{IH}	Input High Current	PCLK, nPCLK $V_{IN} = V_{DD_IN} = V_{DD_MAX}$			150	μA
I_{IL}	Input Low Current	PCLK $V_{IN} = 0V, V_{DD_IN} = V_{DD_MAX}$	-10			μA
		nPCLK $V_{IN} = 0V, V_{DD_IN} = V_{DD_MAX}$	-150			μA
V_{REF}	Reference Voltage	$I_{REF} = 100\mu A, V_{DD_IN} = 3.3V$	2.05		2.45	V
		$I_{REF} = 100\mu A, V_{DD_IN} = 2.5V$	1.55		1.85	V
V_{OH}	Output High Voltage ^[b]		$V_{DD} - 1.1$		$V_{DD} - 0.7$	V
V_{OL}	Output Low Voltage ^[b]		$V_{DD} - 1.8$		$V_{DD} - 1.4$	V

[a] Core supply voltage cannot be lower than the output supply voltage.

[b] Outputs terminated with 50Ω to $V_{DD} - 2V$.

AC Electrical Characteristics

Table 11. AC Electrical Characteristics, $V_{DD_IN} = V_{DD} = 2.5V \pm 5\%$, $3.3V \pm 5\%$, $T_A = -40^\circ C$ to $+85^\circ C$ ^[a]

Symbol	Parameter		Test Conditions	Minimum	Typical	Maximum	Units
f_{REF}	Input Frequency					2	GHz
$\Delta V/\Delta t$	Input Edge Rate			1.5			V/ns
t_{PD}	Propagation Delay ^{[b], [c]}	PCLK to any Qx			290	400	ps
/sk(o)	Output Skew ^{[d], [e]}				40	60	ps
/sk(p)	Pulse Skew ^[f]		$f_{REF} = 100MHz$		4	20	ps
/sk(pp)	Part-to-part Skew ^{[e], [g]}					200	ps
t_{JIT}	Buffer Additive Phase Jitter, RMS; $V_{DDIN} = V_{DD} = 3.3V$ 750mV amplitude; see Additive Phase Jitter		$f_{REF} = 156.25MHz$; square wave, $V_{PP} = 1V$; Integration range: 1kHz – 40MHz		57	60	fs
			$f_{REF} = 156.25MHz$ square wave, $V_{PP} = 1V$; Integration range: 12kHz – 20MHz		39	43	fs
$\Phi_N(\geq 30M)$	Clock Single-side Band Phase Noise		$\geq 30MHz$ offset from carrier and noise floor		≤ -160		dBc/Hz
t_R / t_F	Output Rise/ Fall Time		10–90%		160	300	ps
			20–80%		105	200	ps
V_{PP}	Input Voltage Amplitude ^{[h], [i]}	PCLK, nPCLK		0.15		1.2	V
V_{PP_DIFF}	Differential Input Voltage Amplitude	PCLK, nPCLK		0.3		2.4	V
V_{CMR}	Common Mode Input Voltage ^{[h], [i], [j]}			1.125		$V_{DD} - (V_{PP}/2)$	V
$V_{O(pp)}$	Output Voltage Swing, Peak-to-peak		SEL_LVDS = 0	0.55	0.73	0.95	V
			SEL_LVDS = 1	0.30	0.43	0.60	V
V_{DIFF_OUT}	Differential Output Voltage Swing, Peak-to-peak		SEL_LVDS = 0	1.10	1.46	1.90	V
			SEL_LVDS = 1	0.60	0.86	1.20	V
V_{OD}	Differential Output Voltage	LVPECL Outputs	SEL_LVDS = 0, outputs loaded with 50Ω to $V_{DD} - 2V$	550	730	950	mV
		LVDS Outputs	SEL_LVDS = 1, outputs loaded with 100Ω	300	430	600	mV

Table 11. AC Electrical Characteristics, $V_{DD_IN} = V_{DD} = 2.5V \pm 5\%$, $3.3V \pm 5\%$, $T_A = -40^{\circ}C$ to $+85^{\circ}C$ ^[a]

Symbol	Parameter		Test Conditions	Minimum	Typical	Maximum	Units
V _{OS}	Offset Voltage	LVDS Outputs	SEL_LVDS = 1, V _{DDIN} = V _{DD} = 3.3V	2.05	2.25	2.45	V
			SEL_LVDS = 1, V _{DDIN} = V _{DD} = 2.5V	1.25	1.45	1.65	V

- [a] Electrical parameters are guaranteed over the specified ambient operating temperature range, which is established when the device is mounted in a test socket with maintained transverse airflow greater than 500lfpm. The device will meet specifications after thermal equilibrium has been reached under these conditions.
- [b] Measured from the differential input crossing point to the differential output crossing point.
- [c] Input $V_{PP} = 400mV$.
- [d] Defined as skew between outputs at the same supply voltage and with equal load conditions. Measured at the differential cross points.
- [e] This parameter is defined in accordance with JEDEC Standard 65.
- [f] Output pulse skew is the absolute value of the difference of the propagation delay times: $|t_{PLH} - t_{PHL}|$.
- [g] Defined as skew between outputs on different devices operating at the same supply voltage, same frequency, same temperature and with equal load conditions. Using the same type of inputs on each device, the outputs are measured at the differential cross points.
- [h] V_{IL} should not be less than $-0.3V$. V_{IH} should not be higher than V_{DD_IN} .
- [i] For single-ended LVCMOS input applications, refer to application section, [Wiring the Differential Input to Accept Single-Ended Levels](#).
- [j] Common Mode Input Voltage is defined as the cross-point voltage.

Additive Phase Jitter

The spectral purity in a band at a specific offset from the fundamental compared to the power of the fundamental is called the *dBc Phase Noise*. This value is normally expressed using a Phase noise plot and is most often the specified plot in many applications. Phase noise is defined as the ratio of the noise power present in a 1Hz band at a specified offset from the fundamental frequency to the power value of the fundamental. This ratio is expressed in decibels (dBm) or a ratio of the power in the 1Hz band to the power in the fundamental. When the required offset is specified, the phase noise is called a *dBc* value, which simply means dBm at a specified offset from the fundamental. By investigating jitter in the frequency domain, we get a better understanding of its effects on the desired application over the entire time record of the signal. It is mathematically possible to calculate an expected bit error rate given a phase noise plot.

Figure 2. Additive Phase Jitter. Frequency: 156.25MHz, Integration Range: 12kHz to 20MHz = 39fs Typical

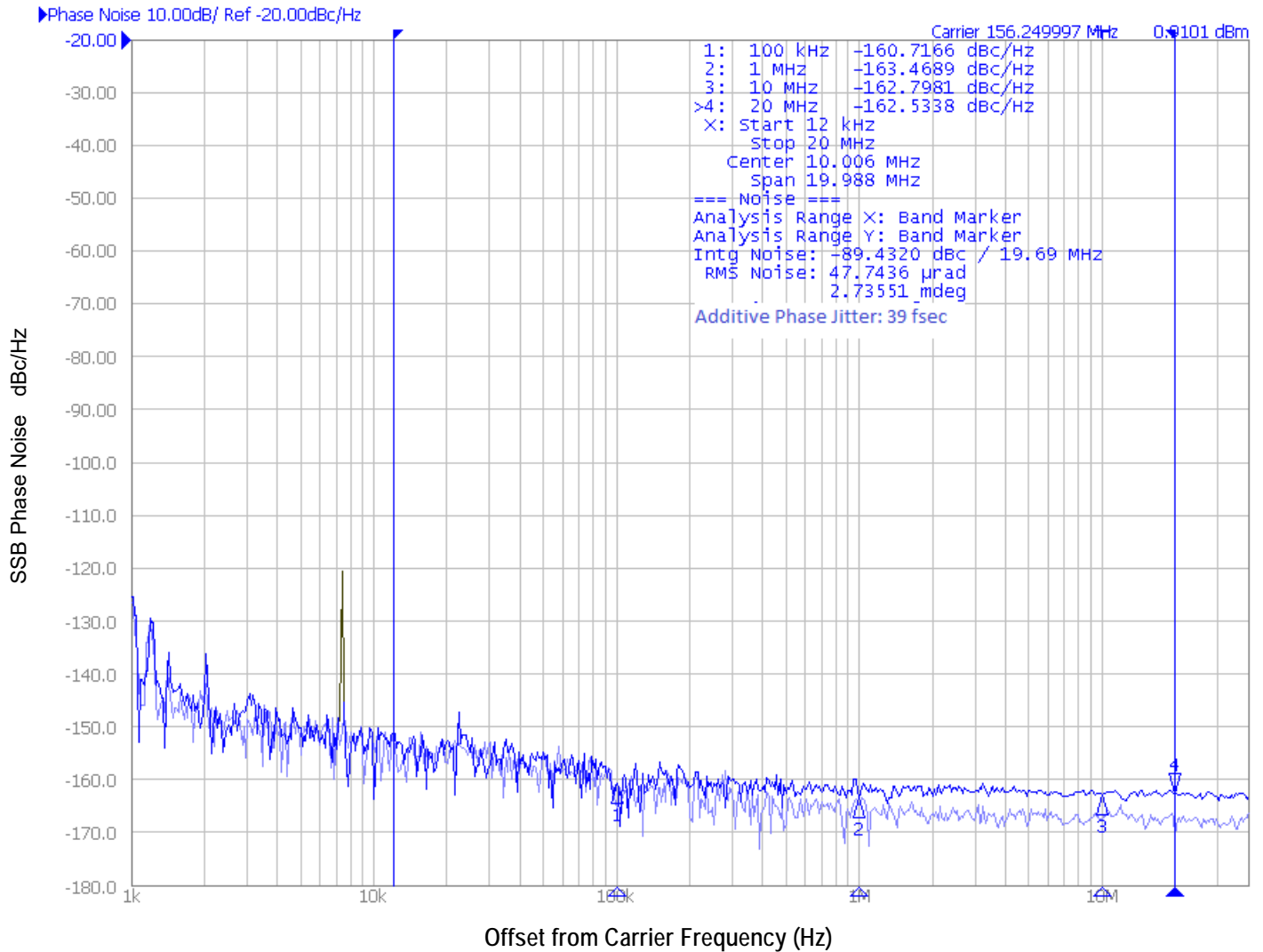

As with most timing specifications, phase noise measurements have issues relating to the limitations of the measurement equipment. The noise floor of the equipment can be higher or lower than the noise floor of the device. Additive phase noise is dependent on both the noise floor of the input source and measurement equipment.

Measured using a Wenzel 156.25MHz Oscillator as the input source.

Applications Information

Recommendations for Unused Input and Output Pins

Inputs

PCLK/nPCLK Inputs

For applications not requiring the use of the differential input, both PCLK and nPCLK can be left floating. Though not required, but for additional protection, a 1kΩ resistor can be tied from PCLK to ground.

Outputs

LVDS Outputs

All unused LVDS output pairs can be either left floating or terminated with 100Ω across. If they are left floating there should be no trace attached.

LVPECL Outputs

All unused LVPECL output pairs can be left floating. We recommend that there is no trace attached. Both sides of the differential output pair should either be left floating or terminated.

VREF

The unused VREF pin can be left floating. We recommend that there is no trace attached.

Wiring the Differential Input to Accept Single-Ended Levels

Figure 3 shows how a differential input can be wired to accept single ended levels. The reference voltage $V_1 = V_{DD}/2$ is generated by the bias resistors R1 and R2. The bypass capacitor (C1) is used to help filter noise on the DC bias. This bias circuit should be located as close to the input pin as possible. The ratio of R1 and R2 might need to be adjusted to position the V_1 in the center of the input voltage swing. For example, if the input clock swing is 1.8V and $V_{DD} = 1.8V$, R1 and R2 value should be adjusted to set V_1 at 0.9V. The values below are for when both the single ended swing and V_{DD} are at the same voltage. This configuration requires that the sum of the output impedance of the driver (R_o) and the series resistance (R_s) equals the transmission line impedance. In addition, matched termination at the input will attenuate the signal in half. This can be done in one of two ways. First, R3 and R4 in parallel should equal the transmission line impedance. For most 50Ω applications, R3 and R4 can be 100Ω. The values of the resistors can be increased to reduce the loading for slower and weaker LVCMOS driver.

Figure 3. Recommended Schematic for Wiring a Differential Input to Accept Single-ended Levels

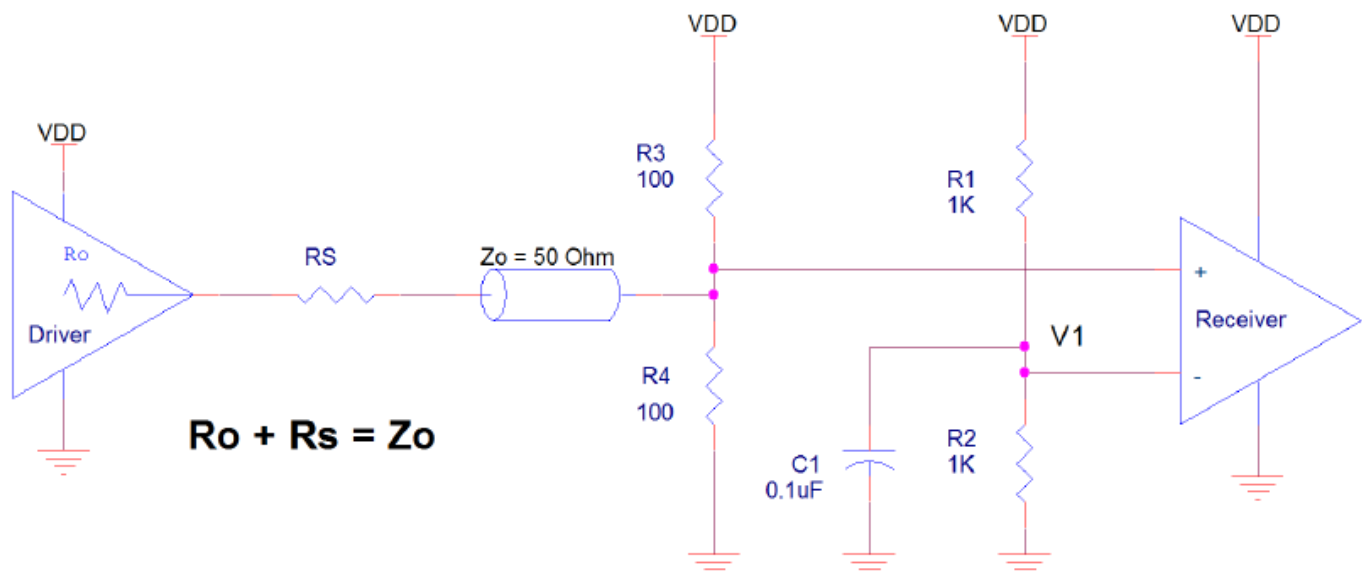

When using single-ended signaling, the noise rejection benefits of differential signaling are reduced. Even though the differential input can handle full rail LVCMOS signaling, it is recommended that the amplitude be reduced while maintaining an edge rate faster than 1V/ns. The datasheet specifies a lower differential amplitude, however this only applies to differential signals. For single-ended applications, the swing can be larger, however V_{IL} cannot be less than -0.3V and V_{IH} cannot be more than $V_{DD} + 0.3V$. Though some of the recommended components might not be used, the pads should be placed in the layout. They can be utilized for debugging purposes. The datasheet specifications are characterized and guaranteed by using a differential signal.

LVDS Driver Termination

For a general LVDS interface, the recommended value for the termination impedance (Z_T) is between 90Ω and 132Ω . The actual value should be selected to match the differential impedance (Z_0) of your transmission line. A typical point-to-point LVDS design uses a 100Ω parallel resistor at the receiver and a 100Ω differential transmission-line environment. In order to avoid any transmission-line reflection issues, the components should be surface mounted and must be placed as close to the receiver as possible. IDT offers a full line of LVDS compliant devices with two types of output structures: current source and voltage source.

The standard termination schematic as shown in Figure 4 can be used with either type of output structure. Figure 5, which can also be used with both output types, is an optional termination with center tap capacitance to help filter common mode noise. The capacitor value should be approximately 50pF. If using a non-standard termination, it is recommended to contact IDT and confirm if the output structure is current source or voltage source type. In addition, since these outputs are LVDS compatible, the input receiver's amplitude and common-mode input range should be verified for compatibility with the output.

Figure 4. Standard LVDS Termination

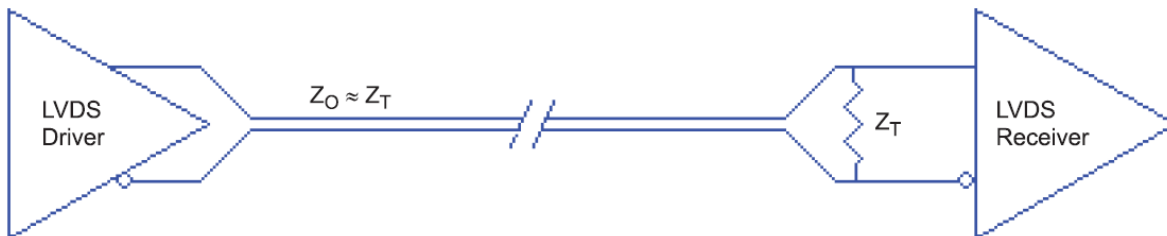
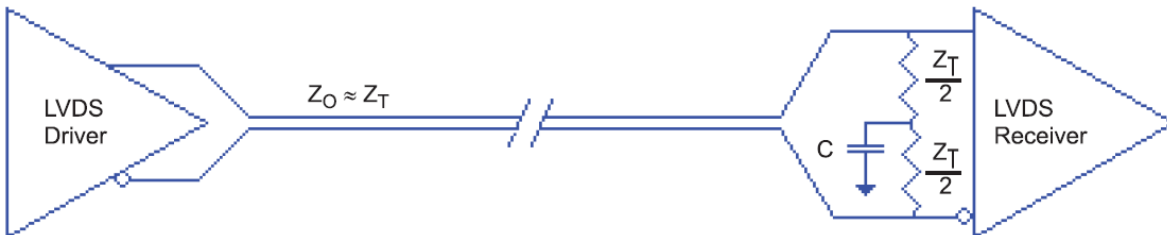

Figure 5. Optional LVDS Termination



Termination for 3.3V LVPECL Outputs

The clock layout topology shown below is a typical termination for LVPECL outputs. The two different layouts mentioned are recommended only as guidelines.

The differential outputs generate ECL/LVPECL compatible outputs. Therefore, terminating resistors (DC current path to ground) or current sources must be used for functionality. These outputs are designed to drive 50Ω transmission lines. Matched impedance techniques should be used to maximize operating frequency and minimize signal distortion. Figure 6 and Figure 7 show two different layouts which are recommended only as guidelines. Other suitable clock layouts may exist and it would be recommended that the board designers simulate to guarantee compatibility across all printed circuit and clock component process variations.

Figure 6. 3.3V LVPECL Output Termination

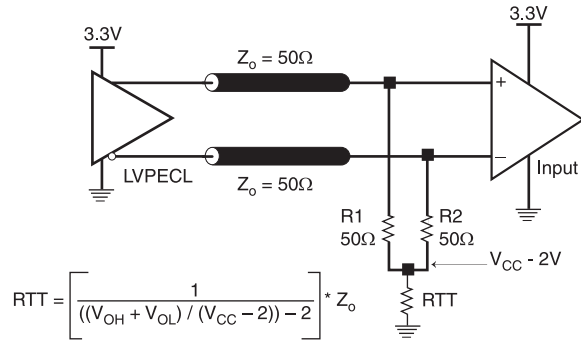
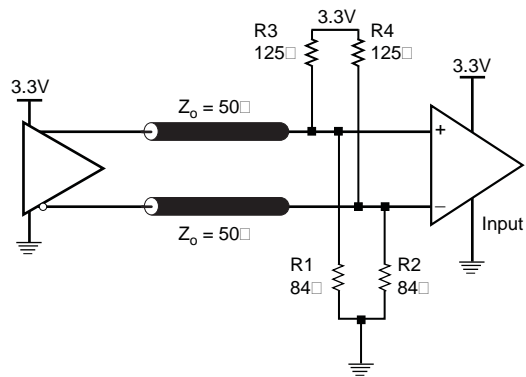

Figure 7. 3.3V LVPECL Output Termination



Termination for 2.5V LVPECL Outputs

Figure 8 and Figure 9 show examples of termination for 2.5V LVPECL driver. These terminations are equivalent to terminating 50Ω to $V_{DD} - 2V$. For $V_{DD} = 2.5V$, the $V_{DD} - 2V$ is very close to ground level. The R3 in Figure 9 can be eliminated and the termination is shown in Figure 10.

Figure 8. 2.5V LVPECL Driver Termination Example

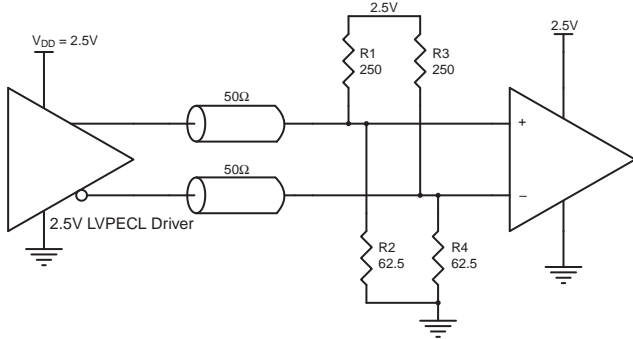

Figure 9. 2.5V LVPECL Driver Termination Example

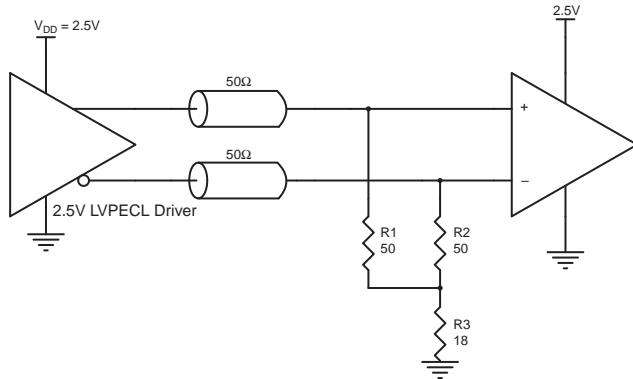
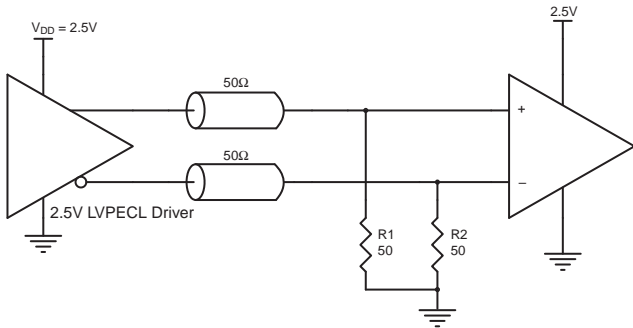

Figure 10. 2.5V LVPECL Driver Termination Example



VFQFPN EPAD Thermal Release Path

In order to maximize both the removal of heat from the package and the electrical performance, a land pattern must be incorporated on the Printed Circuit Board (PCB) within the footprint of the package corresponding to the exposed metal pad or exposed heat slug on the package, as shown in Figure 11. The solderable area on the PCB, as defined by the solder mask, should be at least the same size/shape as the exposed pad/slug area on the package to maximize the thermal/electrical performance. Sufficient clearance should be designed on the PCB between the outer edges of the land pattern and the inner edges of pad pattern for the leads to avoid any shorts.

While the land pattern on the PCB provides a means of heat transfer and electrical grounding from the package to the board through a solder joint, thermal vias are necessary to effectively conduct from the surface of the PCB to the ground plane(s). The land pattern must be connected to ground through these vias. The vias act as “heat pipes”. The number of vias (i.e. “heat pipes”) are application specific and dependent upon the package power dissipation as well as electrical conductivity requirements. Thus, thermal and electrical analysis and/or testing are recommended to determine the minimum number needed. Maximum thermal and electrical performance is achieved when an array of vias is incorporated in the land pattern. It is recommended to use as many vias connected to ground as possible. It is also recommended that the via diameter should be 12mils to 13mils (0.30mm to 0.33mm) with 1oz copper via barrel plating. This is desirable to avoid any solder wicking inside the via during the soldering process which may result in voids in solder between the exposed pad/slug and the thermal land. Precautions should be taken to eliminate any solder voids between the exposed heat slug and the land pattern.

Note: These recommendations are to be used as a guideline only. For further information, please refer to the application note on the *Surface Mount Assembly of Amkor's Thermally/ Electrically Enhance Lead-frame Base Package, Amkor Technology*.

Figure 11. P.C. Assembly for Exposed Pad Thermal Release Path - Side View (Drawing not to scale)

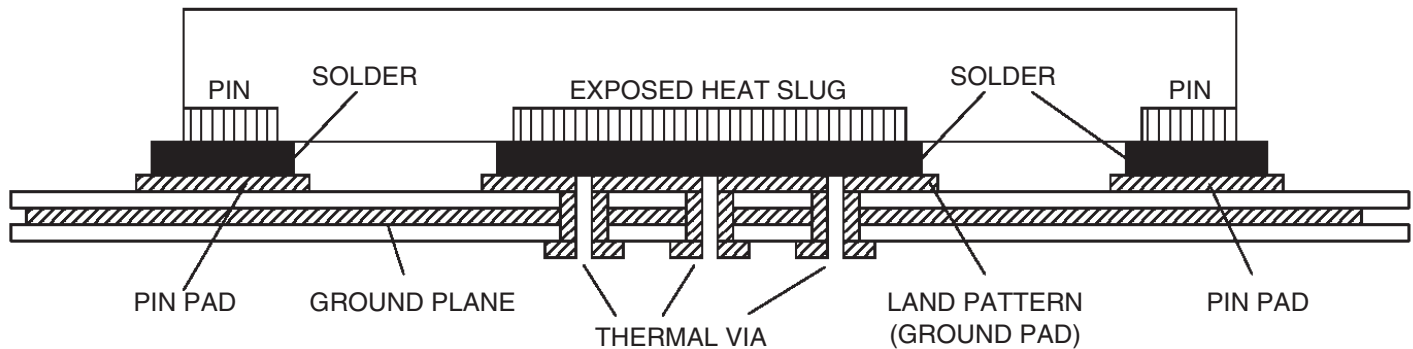

Case Temperature Considerations

This device supports applications in a natural convection environment which does not have any thermal conductivity through ambient air. The printed circuit board (PCB) is typically in a sealed enclosure without any natural or forced air flow and is kept at or below a specific temperature. The device package design incorporates an exposed pad (ePad) with enhanced thermal parameters which is soldered to the PCB where most of the heat escapes from the bottom exposed pad. For this type of application, it is recommended to use the junction-to-board thermal characterization parameter Ψ_{JB} (Psi-JB) to calculate the junction temperature (T_J) and ensure it does not exceed the maximum allowed junction temperature in the [Absolute Maximum Ratings](#) table.

The junction-to-board thermal characterization parameter, Ψ_{JB} , is calculated using the following equation:

$$T_J = T_{CB} + \Psi_{JB} \times P_D, \text{ where}$$

T_J = Junction temperature at steady state condition in ($^{\circ}\text{C}$).

T_{CB} = Case temperature (Bottom) at steady state condition in ($^{\circ}\text{C}$).

Ψ_{JB} = Thermal characterization parameter to report the difference between junction temperature and the temperature of the board measured at the top surface of the board.

P_D = power dissipation (W) in desired operating configuration.

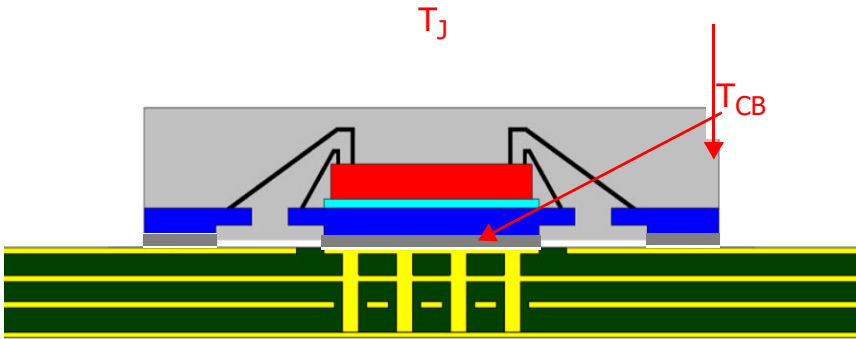

The ePad provides a low thermal resistance path for heat transfer to the PCB and represents the key pathway to transfer heat away from the IC to the PCB. It's critical that the connection of the exposed pad to the PCB is properly constructed to maintain the desired IC case temperature (T_{CB}). A good connection ensures that temperature at the exposed pad (T_{CB}) and the board temperature (T_B) are relatively the same. An improper connection can lead to increased junction temperature, increased power consumption and decreased electrical performance. In addition, there could be long-term reliability issues and increased failure rate.

Example Calculation for Junction Temperature (T_J): $T_J = T_{CB} + \Psi_{JB} \times P_D$

Package type	48-VFQFPN
Body size (mm)	$7 \times 7 \times 0.8$
ePad size (mm)	5.65×5.65
Thermal Via	5×5 Matrix
Ψ_{JB}	$1.2^{\circ}\text{C}/\text{W}$
T_{CB}	105°C
P_D	1.715W

For the above variables, the junction temperature is equal to 107.1°C . Since this is below the maximum junction temperature of 125°C , there are no long-term reliability concerns.

Power Considerations (LVDS Output Mode)

This section provides information on power dissipation and junction temperature for the 8SLVS1118. Equations and example calculations are also provided.

1. Power Dissipation.

The following is the power dissipation for $V_{DD_IN} = V_{DD} = 3.465V$, which gives worst case results.

Maximum current at 85°C: $I_{DD_IN_MAX} + I_{DD_MAX} = 495mA$.

$Power_{MAX} = 3.465V \times 495mA = 1715mW$

2. Junction Temperature.

Junction temperature, T_j , is the temperature at the junction of the bond wire and bond pad directly affects the reliability of the device. The maximum recommended junction temperature is 125°C. Limiting the internal transistor junction temperature, T_j , to 125°C ensures that the bond wire and bond pad temperature remains below 125°C.

The equation for T_j is as follows: $T_j = \theta_{JA} * Pd_{total} + T_A$

T_j = Junction Temperature

θ_{JA} = Junction-to-Ambient Thermal Resistance

Pd_{total} = Total Device Power Dissipation (example calculation is in section 1 above)

T_A = Ambient Temperature

In order to calculate junction temperature, the appropriate junction-to-ambient thermal resistance θ_{JA} must be used. Assuming no air flow and a multi-layer board, the appropriate value is 22.4°C/W per [Table 12](#).

Therefore, T_j for an ambient temperature of 85°C with all outputs switching is:

$85°C + 1.715W * 22.4°C/W = 123.4°C$. This is below the limit of 125°C.

This calculation is only an example. T_j will obviously vary depending on the number of loaded outputs, supply voltage, air flow and the type of board (multi-layer).

Table 12. Thermal Resistance θ_{JA} for 48-VFQFPN, Forced Convection

θ_{JA} (°C/W) vs. Air Flow (m/s)			
Meters per Second	0	1	2
48-Lead VFQFN Multi-Layer PCB, JEDEC Standard Test Boards	22.4	18.9	17.4

Power Considerations (LVPECL Output Mode)

This section provides information on power dissipation and junction temperature for the 8SLVS1118. Equations and example calculations are also provided.

1. Power Dissipation.

The total power dissipation for the 8SLVS1118 is the sum of the core power plus the power dissipated at the output(s). The following is the power dissipation for $V_{DD_IN} = 3.465V$, which gives worst case results.

Note: Please refer to Section 3 for details on calculating power dissipated at the outputs.

$$\text{Power (core)}_{MAX} = V_{DD_IN} * I_{EE_MAX} = 3.465V * 220mA = 762.3mW$$

$$\text{Power (outputs)}_{MAX} = 35mW/\text{Loaded Output pair}$$

$$\text{If all outputs are loaded, the total power is } 18 * 35mW = 630mW$$

$$\text{Total Power}_{MAX} (3.465V, \text{ with all outputs switching}) = 762.3mW + 630mW = 1392.3mW$$

2. Junction Temperature.

Junction temperature, T_j , is the temperature at the junction of the bond wire and bond pad directly affects the reliability of the device. The maximum recommended junction temperature is 125°C. Limiting the internal transistor junction temperature, T_j , to 125°C ensures that the bond wire and bond pad temperature remains below 125°C.

$$\text{The equation for } T_j \text{ is as follows: } T_j = \theta_{JA} * Pd_{total} + T_A$$

T_j = Junction Temperature

θ_{JA} = Junction-to-Ambient Thermal Resistance

Pd_{total} = Total Device Power Dissipation (example calculation is in section 1 above)

T_A = Ambient Temperature

In order to calculate junction temperature, the appropriate junction-to-ambient thermal resistance θ_{JA} must be used. Assuming no air flow and a multi-layer board, the appropriate value is 22.4°C/W per [Table 13](#).

Therefore, T_j for an ambient temperature of 85°C with all outputs switching is:

$$85^\circ\text{C} + 1.3923W * 22.4^\circ\text{C/W} = 116.2^\circ\text{C}. \text{ This is below the limit of } 125^\circ\text{C}.$$

This calculation is only an example. T_j will obviously vary depending on the number of loaded outputs, supply voltage, air flow and the type of board (multi-layer).

Table 13. Thermal Resistance θ_{JA} for 48-VFQFPN, Forced Convection

θ_{JA} by Velocity			
Meters per Second	0	1	2
Multi-Layer PCB, JEDEC Standard Test Boards	22.4°C/W	18.9°C/W	17.4°C/W

3. Calculations and Equations.

The purpose of this section is to calculate the power dissipation for the LVPECL output pair. LVPECL output driver circuit and termination are shown in Table 10.

Figure 12. LVPECL Driver Circuit and Termination

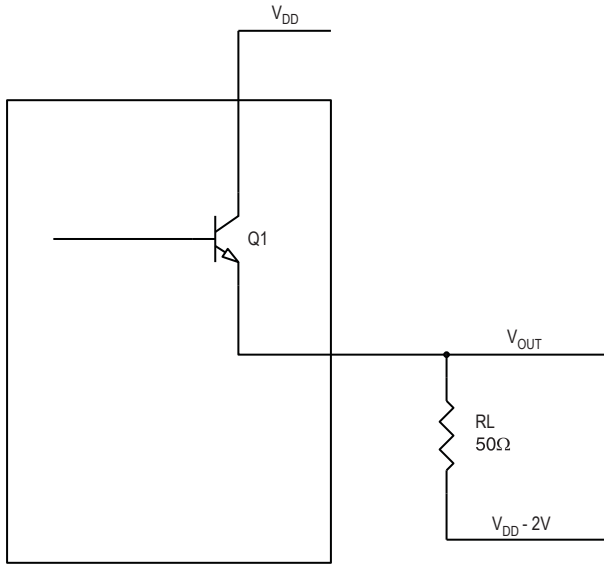

To calculate worst case power dissipation at the output(s), use the following equations which assume a 50Ω load, and a termination voltage of $V_{DD} - 2V$.

- For logic high, $V_{OUT} = V_{OH_MAX} = V_{DD_MAX} - 0.7V$
 $(V_{DD_MAX} - V_{OH_MAX}) = 0.7V$
- For logic low, $V_{OUT} = V_{OL_MAX} = V_{DD_MAX} - 1.4V$
 $(V_{DD_MAX} - V_{OL_MAX}) = 1.4V$

Pd_H is the power dissipation when the output drives high.

Pd_L is the power dissipation when the output drives low.

$$Pd_H = [(V_{OH_MAX} - (V_{DD_MAX} - 2V))/R_L] * (V_{DD_MAX} - V_{OH_MAX}) = [(2V - (V_{DD_MAX} - V_{OH_MAX}))/R_L] * (V_{DD_MAX} - V_{OH_MAX}) = [(2V - 0.7V)/50\Omega] * 0.7V = 18.2mW$$

$$Pd_L = [(V_{OL_MAX} - (V_{DD_MAX} - 2V))/R_L] * (V_{DD_MAX} - V_{OL_MAX}) = [(2V - (V_{DD_MAX} - V_{OL_MAX}))/R_L] * (V_{DD_MAX} - V_{OL_MAX}) = [(2V - 1.4V)/50\Omega] * 1.4V = 16.8mW$$

$$\text{Total Power Dissipation per output pair} = Pd_H + Pd_L = 35mW$$

Package Outline Drawings

The package outline drawings are appended at the end of this document and are accessible from the link below. The package information is the most current data available.

www.idt.com/document/psc/48-vfqfjn-package-outline-drawing-70-x-70-x-085-mm-body-05mm-pitchepad-565-x-565-mm-nlg48p1

Marking Diagram

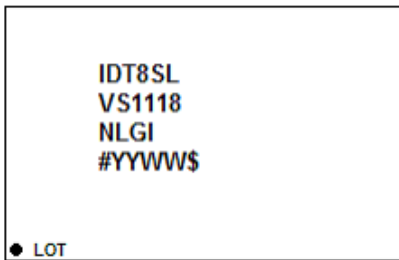

1. Line 1, line 2, and line 3 indicates the part number.
2. Line 4:
 - “#” indicates stepping.
 - “YYWW” indicates the date code (YY denotes the last two digits of the year, and “WW” denotes a work week number that the part was assembled).
 - “\$” indicates the mark code.

Ordering Information

Table 14. Ordering Information

Part/Order Number	Marking	Package	Shipping Packaging	Temperature
8SLVS1118NLGI	IDT8SLVS1118NLGI	48-VFQFPN, Lead-Free	Tray	-40°C to +85°C
8SLVS1118NLGI8	IDT8SLVS1118NLGI	48-VFQFPN, Lead-Free; Quadrant 1 (EIA-481-C)	Tape & Reel, Pin 1 Orientation: EIA-481-C	
8SLVS1118NLGI/W	IDT8SLVS1118NLGI	48-VFQFPN, Lead-Free; Quadrant 2 (EIA-481-D/E)	Tape & Reel, Pin 1 Orientation: EIA-481-D/E	

Table 15. Pin 1 Orientation in Tape and Reel Packaging

Part Number Suffix	Pin 1 Orientation	Illustration
8SLVS1118NLGI8	Quadrant 1 (EIA-481-C)	
8SLVS1118NLGI/W	Quadrant 2 (EIA-481-D/E)	

Revision History

Revision Date	Description of Change
January 15, 2019	<ul style="list-style-type: none"><li data-bbox="423 296 1187 327">▪ Removed "2.5V LVPECL Input with Built-in 50Ω Termination Interface"<li data-bbox="423 331 1187 363">▪ Removed "3.3V LVPECL Input with Built-in 50Ω Termination Interface"<li data-bbox="423 367 1219 399">▪ Updated the package outline drawings; however, no mechanical changes
July 17, 2017	Initial release.

IMPORTANT NOTICE AND DISCLAIMER

RENESAS ELECTRONICS CORPORATION AND ITS SUBSIDIARIES (“RENESAS”) PROVIDES TECHNICAL SPECIFICATIONS AND RELIABILITY DATA (INCLUDING DATASHEETS), DESIGN RESOURCES (INCLUDING REFERENCE DESIGNS), APPLICATION OR OTHER DESIGN ADVICE, WEB TOOLS, SAFETY INFORMATION, AND OTHER RESOURCES “AS IS” AND WITH ALL FAULTS, AND DISCLAIMS ALL WARRANTIES, EXPRESS OR IMPLIED, INCLUDING, WITHOUT LIMITATION, ANY IMPLIED WARRANTIES OF MERCHANTABILITY, FITNESS FOR A PARTICULAR PURPOSE, OR NON-INFRINGEMENT OF THIRD PARTY INTELLECTUAL PROPERTY RIGHTS.

These resources are intended for developers skilled in the art designing with Renesas products. You are solely responsible for (1) selecting the appropriate products for your application, (2) designing, validating, and testing your application, and (3) ensuring your application meets applicable standards, and any other safety, security, or other requirements. These resources are subject to change without notice. Renesas grants you permission to use these resources only for development of an application that uses Renesas products. Other reproduction or use of these resources is strictly prohibited. No license is granted to any other Renesas intellectual property or to any third party intellectual property. Renesas disclaims responsibility for, and you will fully indemnify Renesas and its representatives against, any claims, damages, costs, losses, or liabilities arising out of your use of these resources. Renesas' products are provided only subject to Renesas' Terms and Conditions of Sale or other applicable terms agreed to in writing. No use of any Renesas resources expands or otherwise alters any applicable warranties or warranty disclaimers for these products.

(Rev.1.0 Mar 2020)

Corporate Headquarters

TOYOSU FORESIA, 3-2-24 Toyosu,
Koto-ku, Tokyo 135-0061, Japan
www.renesas.com

Contact Information

For further information on a product, technology, the most up-to-date version of a document, or your nearest sales office, please visit:
www.renesas.com/contact/

Trademarks

Renesas and the Renesas logo are trademarks of Renesas Electronics Corporation. All trademarks and registered trademarks are the property of their respective owners.