

GENERAL DESCRIPTION

The 873991-147 is a low voltage, low skew, 3.3V LVPECL or ECL Clock Generator and a member of the family of High Performance Clock Solutions from IDT. The 873991-147 has two selectable clock inputs. The CLK, nCLK pair can accept LVPECL, LVDS, LVHSTL, SSTL and HCSL input levels and, the REF_CLK pin can accept a LVCMOS or LVTTTL input levels. This device has a fully integrated PLL along with frequency configurable outputs. An external feedback input and output regenerates clocks with “zero delay”.

The four independent banks of outputs each have their own output dividers, which allow the device to generate a multitude of different bank frequency ratios and output-to-input frequency ratios. The output frequency range is 25MHz to 480MHz and the input frequency range is 6.25MHz to 120MHz. The PLL_EN input can be used to bypass the PLL for test and system debug purposes. In bypass mode, the input clock is routed around the PLL and into the internal output dividers.

The 873991-147 also has a SYNC output which can be used for system synchronization purposes. It monitors Bank A and Bank C outputs for coincident rising edges and signals a pulse per the timing diagrams in this data sheet. This feature is used primarily in applications where Bank A and Bank C are running at different frequencies, and is particularly useful when they are running at non-integer multiples of each other.

Example Applications:

1. Line Card Multiplier: Multiply 19.44MHz from a back-plane to 77.76MHz on the line card ASIC and Serdes.
2. Zero Delay Buffer: Fan out up to thirteen 100MHz copies from a reference clock to multiple processing units on an embedded system.

FEATURES

- Fourteen differential 3.3V LVPECL/ECL outputs
- Selectable differential or REF_CLK inputs
- CLK, nCLK can accept the following input levels: LVPECL, LVDS, LVHSTL, SSTL, HCSL
- REF_CLK accepts the following input levels: LVCMOS, LVTTTL
- Input clock frequency range: 6.25MHz to 120MHz
- Maximum output frequency: 480MHz
- VCO range: 200MHz to 960MHz
- Output skew: 250ps (maximum), outputs at the same frequency
- Cycle-to-cycle jitter: 55ps (maximum)
- LVPECL mode operating voltage supply range: $V_{CC} = 3.135V$ to $3.465V$, $V_{EE} = 0V$
- ECL mode operating voltage supply range: $V_{CC} = 0V$, $V_{EE} = -3.465V$ to $-3.135V$
- 0°C to 50°C ambient operating temperature
- Available in lead-free (RoHS 6) package
- **Use replacement part 873996AYLF**

PIN ASSIGNMENT

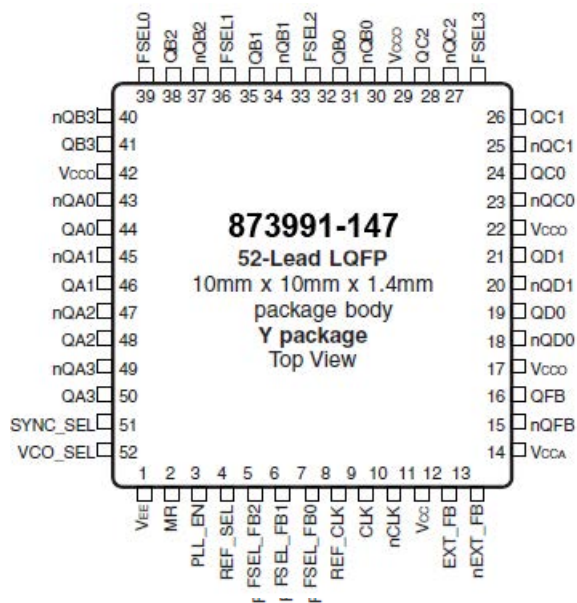

BLOCK DIAGRAM

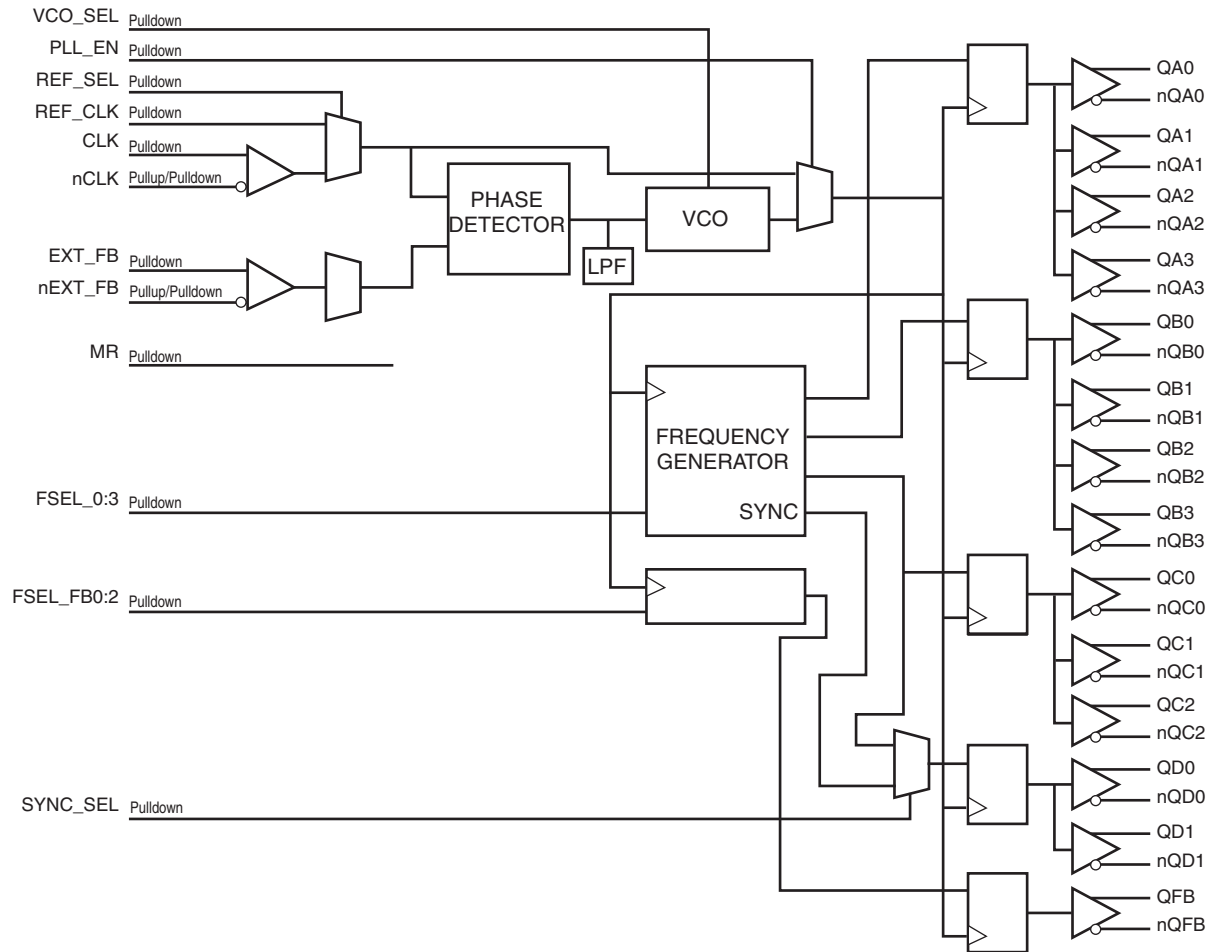

TABLE 1. PIN DESCRIPTIONS

Number	Name	Type		Description
1	V _{EE}	Power		Negative supply pin.
2	MR	Input	Pulldown	Active High Master Reset. When logic HIGH, the internal dividers are reset causing the true outputs (Qx) to go low and the inverted outputs (nQx) to go high. When logic LOW, the internal dividers and the outputs are enabled. LVCMOS/LVTTL interface levels.
3	PLL_EN	Input	Pulldown	PLL enable pin. When logic LOW, PLL is enabled. When logic HIGH, PLL is in bypass mode. LVCMOS/LVTTL interface levels.
4	REF_SEL	Input	Pulldown	Selects between the different reference inputs as the PLL reference source. When logic LOW, selects CLK/nCLK. When logic HIGH, selects REF_CLK. LVCMOS/LVTTL interface levels.
5 6 7	FSEL_FB2 FSEL_FB1 FSEL_FB0	Input	Pulldown	Feedback frequency select pins. LVCMOS/LVTTL interface levels.
8	REF_CLK	Input	Pulldown	Reference clock input. LVCMOS/LVTTL interface levels.
9	CLK	Input	Pulldown	Non-inverting differential clock input.
10	nCLK	Input	Pullup/ Pulldown	Inverting differential clock input. V _{cc} /2 default when left floating.
11	V _{cc}	Power		Core supply pin.
12	EXT_FB	Input	Pulldown	Non-inverting external feedback input.
13	nEXT_FB	Input	Pullup/ Pulldown	Inverting external feedback input. V _{cc} /2 default when left floating.
14	V _{cca}	Power		Analog supply pin.
15 16	nQFB QFB	Output		Differential feedback output pair. LVPECL Interface levels.
17, 22, 30, 42	V _{cco}	Power		Output supply pins.
18, 19	nQD0, QD0	Output		Differential output pair. LVPECL interface levels.
20, 21	nQD1, QD1	Output		Differential output pair. LVPECL interface levels.
23, 24	nQC0, QC0	Output		Differential output pair. LVPECL interface levels.
25, 26	nQC1, QC1	Output		Differential output pair. LVPECL interface levels.
27 33 36 39	FSEL3 FSEL2 FSEL1 FSEL0	Input	Pulldown	Frequency select pins. LVCMOS/LVTTL interface levels.
28, 29	nQC2, QC2	Output		Differential output pair. LVPECL interface levels.
31, 32	nQB0, QB0	Output		Differential output pair. LVPECL interface levels.
34, 35	nQB1, QB1	Output		Differential output pair. LVPECL interface levels.
37, 38	nQB2, QB2	Output		Differential output pair. LVPECL interface levels.
40, 41	nQB3, QB3	Output		Differential output pair. LVPECL interface levels.
43, 44	nQA0, QA0	Output		Differential output pair. LVPECL interface levels.
45, 46	nQA1, QA1	Output		Differential output pair. LVPECL interface levels.
47, 48	nQA2, QA2	Output		Differential output pair. LVPECL interface levels.
49, 50	nQA3, QA3	Output		Differential output pair. LVPECL interface levels.
51	SYNC_SEL	Input	Pulldown	SYNC output select pin. When LOW, the SYNC output follows the timing diagram (page 5). When HIGH, QD output follows QC output LVCMOS/LVTTL interface levels..
52	VCO_SEL	Input	Pulldown	Selects VCO range. LVCMOS/LVTTL interface levels.

NOTE: Pullup and Pulldown refer to internal input resistors. See Table 2, Pin Characteristics, for typical values.

TABLE 2. PIN CHARACTERISTICS

Symbol	Parameter	Test Conditions	Minimum	Typical	Maximum	Units
C_{IN}	Input Capacitance			4		pF
$R_{PULLDOWN}$	Input Pulldown Resistor			51		k Ω
R_{PULLUP}	Input Pullup Resistor			51		k Ω

TABLE 3A. SELECT PIN FUNCTION TABLE

Inputs				Outputs		
FSEL3	FSEL2	FSEL1	FSEL0	QA _x	QB _x	QC _x
0	0	0	0	÷ 2	÷ 2	÷ 2
0	0	0	1	÷ 2	÷ 2	÷ 4
0	0	1	0	÷ 2	÷ 4	÷ 4
0	0	1	1	÷ 2	÷ 2	÷ 6
0	1	0	0	÷ 2	÷ 6	÷ 6
0	1	0	1	÷ 2	÷ 4	÷ 6
0	1	1	0	÷ 2	÷ 4	÷ 8
0	1	1	1	÷ 2	÷ 6	÷ 8
1	0	0	0	÷ 2	÷ 2	÷ 8
1	0	0	1	÷ 2	÷ 8	÷ 8
1	0	1	0	÷ 4	÷ 4	÷ 6
1	0	1	1	÷ 4	÷ 6	÷ 6
1	1	0	0	÷ 4	÷ 6	÷ 8
1	1	0	1	÷ 6	÷ 6	÷ 8
1	1	1	0	÷ 6	÷ 8	÷ 8
1	1	1	1	÷ 8	÷ 8	÷ 8

TABLE 3B. FEEDBACK CONTROL FUNCTION TABLE

Inputs			Outputs
FSEL_FB2	FSEL_FB1	FSEL_FB0	QFB
0	0	0	÷2
0	0	1	÷4
0	1	0	÷6
0	1	1	÷8
1	0	0	÷8
1	0	1	÷16
1	1	0	÷24
1	1	1	÷32

TABLE 3C. INPUT CONTROL FUNCTION TABLE

Control Input Pin	Logic 0	Logic 1
PLL_EN	Enables PLL	Bypasses PLL
VCO_SEL	fVCO	fVCO/2
REF_SEL	Selects CLK/nCLK	Selects REF_CLK
MR	---	Resets outputs
SYNC_SEL	Selects outputs	Match QC Outputs

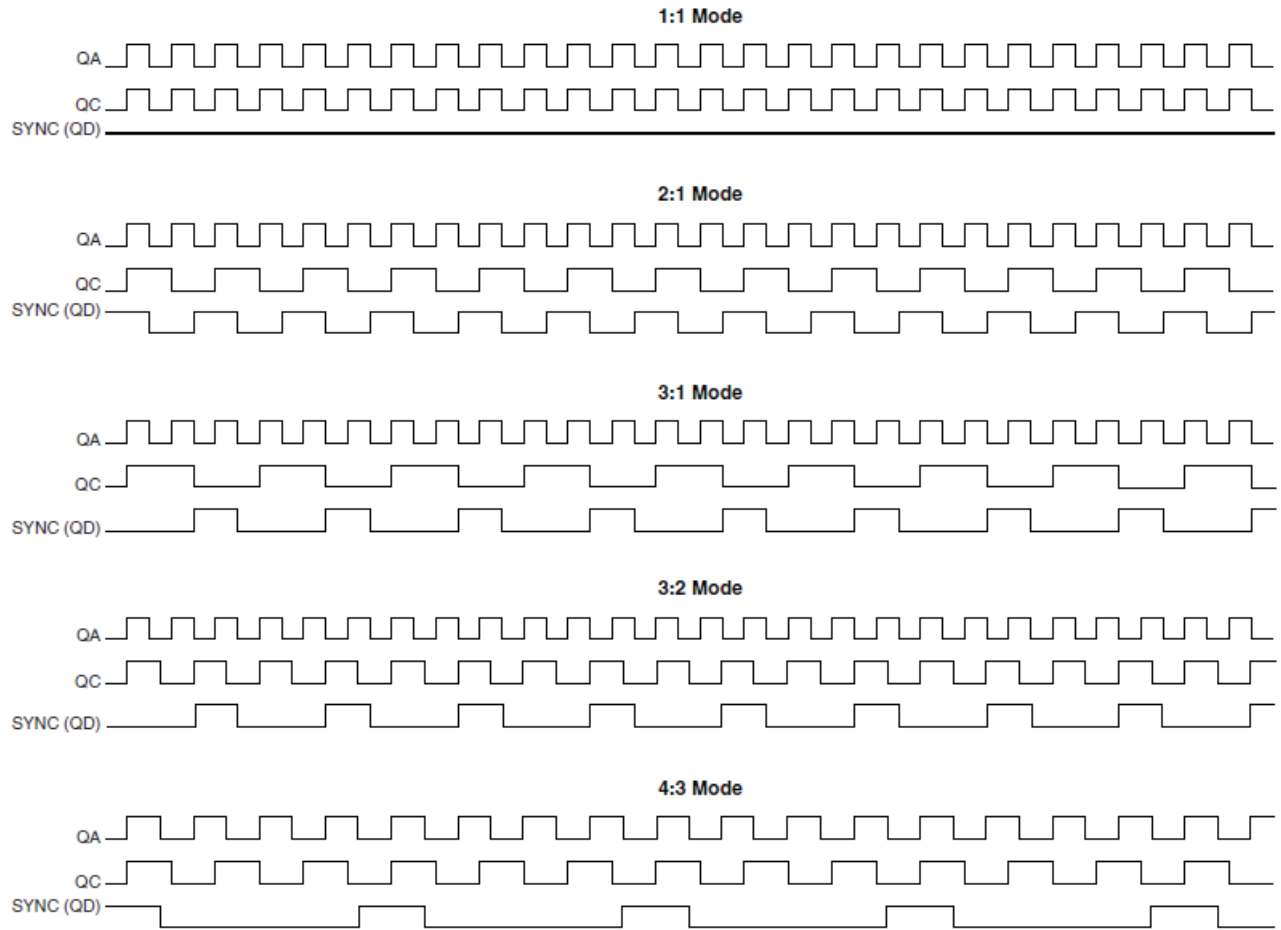

FIGURE 1. TIMING DIAGRAMS

ABSOLUTE MAXIMUM RATINGS

Supply Voltage, V_{CC}	4.6V
Inputs, V_I	-0.5V to $V_{CC} + 0.5V$
Outputs, I_O	
Continuous Current	50mA
Surge Current	100mA
Package Thermal Impedance, θ_{JA}	55.5°C/W (0 mps)
Storage Temperature, T_{STG}	-65°C to 150°C

NOTE: Stresses beyond those listed under Absolute Maximum Ratings may cause permanent damage to the device. These ratings are stress specifications only. Functional operation of product at these conditions or any conditions beyond those listed in the *DC Characteristics* or *AC Characteristics* is not implied. Exposure to absolute maximum rating conditions for extended periods may affect product reliability.

TABLE 4A. POWER SUPPLY DC CHARACTERISTICS, $V_{CC} = V_{CCO} = 3.3V \pm 5\%$, $V_{EE} = 0V$, $T_A = 0^\circ C$ TO $50^\circ C$

Symbol	Parameter	Test Conditions	Minimum	Typical	Maximum	Units
V_{CC}	Core Supply Voltage		3.135	3.3	3.465	V
V_{CCA}	Analog Supply Voltage		$V_{CC} - 0.15$	3.3	V_{CC}	V
V_{CCO}	Output Supply Voltage		3.135	3.3	3.465	V
I_{CC}	Power Supply Current				150	mA
I_{CCA}	Analog Supply Current				15	mA
I_{CCO}	Output Supply Current				95	mA

TABLE 4B. LVCMOS/LVTTL DC CHARACTERISTICS, $V_{CC} = V_{CCO} = 3.3V \pm 5\%$, $V_{EE} = 0V$, $T_A = 0^\circ C$ TO $50^\circ C$

Symbol	Parameter	Test Conditions	Minimum	Typical	Maximum	Units
V_{IH}	Input High Voltage	PLL_EN, VCO_SEL, REF_SEL, SYNC_SEL, FSEL_FB0:FSEL_FB2, FSEL0:FSEL3, MR	2		$V_{CC} + 0.3$	V
		REF_CLK	2		$V_{CC} + 0.3$	V
V_{IL}	Input Low Voltage	PLL_EN, VCO_SEL, REF_SEL, SYNC_SEL, FSEL_FB0:FSEL_FB2, FSEL0:FSEL3, MR	-0.3		0.8	V
		REF_CLK	-0.3		1.3	V
I_{IH}	Input High Current	$V_{CC} = V_{IN} = 3.465V$			150	μA
I_{IL}	Input Low Current	$V_{IN} = 0V, V_{CC} = 3.465V$	-5			μA

TABLE 4C. DIFFERENTIAL DC CHARACTERISTICS, $V_{CC} = V_{CCO} = 3.3V \pm 5\%$, $V_{EE} = 0V$, $T_A = 0^\circ C$ TO $50^\circ C$

Symbol	Parameter	Test Conditions	Minimum	Typical	Maximum	Units
I_{IH}	Input High Current	CLK/nCLK, EXT_FB/ nEXT_FB $V_{CC} = V_{IN} = 3.465V$			150	μA
I_{IL}	Input Low Current	CLK, EXT_FB $V_{CC} = 3.465V, V_{IN} = 0V$	-5			μA
		nCLK, nEXT_FB $V_{CC} = 3.465V, V_{IN} = 0V$	-150			μA
V_{PP}	Peak-to-Peak Input Voltage; NOTE 1		0.15		1.3	V
V_{CMB}	Common Mode Input Voltage; NOTE 1, 2		$V_{EE} + 0.5$		$V_{CC} - 0.85$	V

NOTE 1: V_{IL} should not be less than -0.3V.

NOTE 2: Common mode voltage is defined as V_{IH} .

TABLE 4D. LVPECL DC CHARACTERISTICS, $V_{CC} = V_{CCO} = 3.3V \pm 5\%$, $V_{EE} = 0V$, $T_A = 0^\circ C$ TO $50^\circ C$

Symbol	Parameter	Test Conditions	Minimum	Typical	Maximum	Units
V_{OH}	Output High Voltage; NOTE 2		$V_{CCO} - 1.4$		$V_{CCO} - 0.9$	V
V_{OL}	Output Low Voltage; NOTE 2		$V_{CCO} - 2.0$		$V_{CCO} - 1.7$	V
V_{SWING}	Peak-to-Peak Output Voltage Swing		0.6		1	V

TABLE 5. PLL INPUT REFERENCE CHARACTERISTICS, $V_{CC} = V_{CCO} = 3.3V \pm 5\%$, $T_A = 0^\circ C$ TO $50^\circ C$

Symbol	Parameter	Test Conditions	Minimum	Typical	Maximum	Units
t_R / t_F	Input Rise/Fall Time	REF_CLK			3	ns
f_{REF}	Reference Frequency VCO_SEL = 0	Feedback $\div 6$	66.66		120	MHz
		Feedback $\div 8$	50		120	MHz
		Feedback $\div 16$	25		60	MHz
		Feedback $\div 24$	16.66		40	MHz
	Reference Frequency VCO_SEL = 1	Feedback $\div 4$	50		120	MHz
		Feedback $\div 6$	33.33		80	MHz
		Feedback $\div 8$	25		60	MHz
		Feedback $\div 16$	12.5		30	MHz
		Feedback $\div 24$	8.33		20	MHz
		Feedback $\div 32$	6.25		15	MHz
f_{REFDC}	Reference Input Duty Cycle		25		75	%

NOTE: These parameters are guaranteed by design, but are not tested in production.

TABLE 6. AC CHARACTERISTICS, $V_{cc} = V_{cco} = 3.3V \pm 5\%$, $T_A = 0^\circ C$ TO $50^\circ C$

Symbol	Parameter	Test Conditions	Minimum	Typical	Maximum	Units
f_{MAX}	Output Frequency	QA, QB, QC			480	MHz
		QD	SYNC_SEL = 1		400	MHz
		QD; NOTE 1	SYNC_SEL = 0		200	MHz
$t(\emptyset)$	Static Phase Offset; NOTE 2, 3	CLK, nCLK		170	325	ps
$t_{sk(o)}$	Output Skew; NOTE 4, 5				250	ps
$t_{sk(w)}$	Multiple Frequency Skew; NOTE 5, 6				350	ps
$t_{jit(cc)}$	Cycle-to-Cycle Jitter; NOTE 5	VCO_SEL = 0			50	ps
		VCO_SEL = 1			55	ps
$t_{jit(hcyc)}$	Half-Cycle Jitter	NOTE 7	VCO_SEL = 0		375	ps
		NOTE 8	VCO_SEL = 1		130	ps
f_{VCO}	PLL VCO Lock Range; NOTE 9	VCO_SEL = 0	400		960	MHz
		VCO_SEL = 1	200		480	MHz
t_{LOCK}	PLL Lock Time				10	ms
t_R / t_F	Output Rise/Fall Time	20% to 80%	0.2		1	ns
odc	Output Duty Cycle	NOTE 7	VCO_SEL = 0	40	60	%
		NOTE 8	VCO_SEL = 1	45	55	%

NOTE: Electrical parameters are guaranteed over the specified ambient operating temperature range, which is established when the device is mounted in a test socket with maintained transverse airflow greater than 500 lfm. The device will meet specifications after thermal equilibrium has been reached under these conditions.

All parameters measured at f_{MAX} unless noted otherwise.

NOTE 1: SYNC output (QD when SYNC_SEL = 0) operation guaranteed to 800MHz maximum VCO frequency.

NOTE 2: Defined as the time difference between the input reference clock and the average feedback input signal when the PLL is locked and the input reference frequency is stable.

NOTE 3: Static phase offset is specified for an input frequency of 50MHz with feedback in $\div 8$.

NOTE 4: Defined as skew between outputs at the same supply voltage and with equal load conditions. Measured at the output differential cross points.

NOTE 5: This parameter is defined in accordance with JEDEC Standard 65.

NOTE 6: Defined as skew across banks of outputs switching in the same direction operating at different frequencies with the same supply voltages and equal load conditions. Measured at $V_{cco}/2$.

NOTE 7: This value is based on the VCO frequency = 960MHz, output divider = 2.

NOTE 8: This value is based on the VCO frequency = 480MHz, output divider = 2.

NOTE 9: When VCO_SEL = 0, the PLL will be unstable with feedback configurations of $\div 2$, $\div 4$, $\div 32$ and some $\div 6$. When VCO_SEL = 1, the PLL will be unstable with a feedback configuration of $\div 2$.

PARAMETER MEASUREMENT INFORMATION

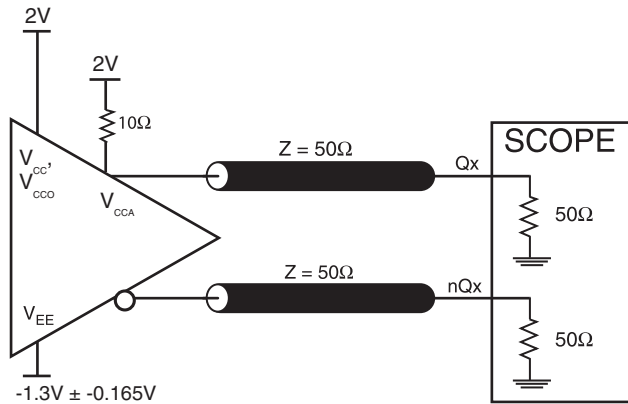

OUTPUT LOAD AC TEST CIRCUIT

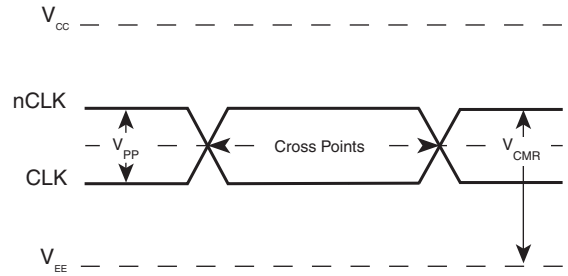

DIFFERENTIAL INPUT LEVELS

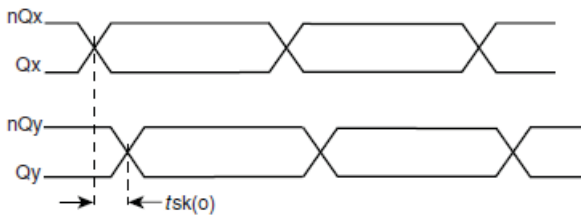

OUTPUT SKEW

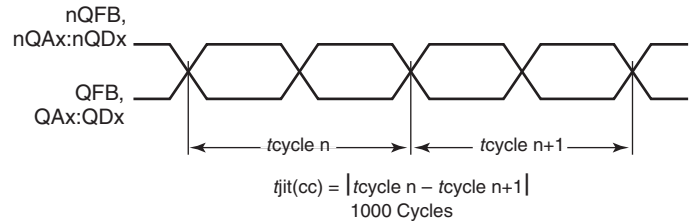

CYCLE-TO-CYCLE JITTER

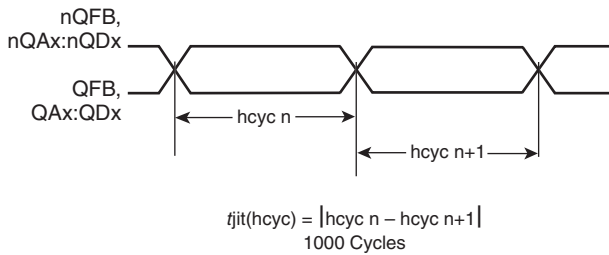

HALF-CYCLE JITTER

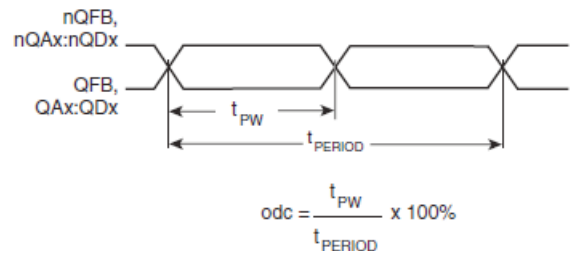

OUTPUT DUTY CYCLE/PULSE WIDTH/PERIOD

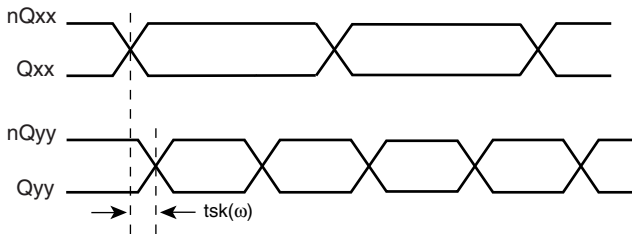

MULTIPLE FREQUENCY SKEW

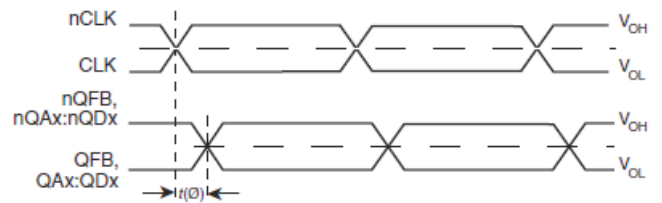

STATIC PHASE OFFSET

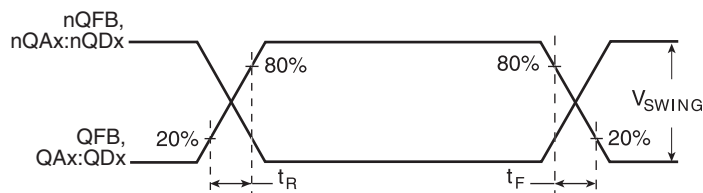

OUTPUT RISE/FALL TIME

APPLICATIONS INFORMATION

POWER SUPPLY FILTERING TECHNIQUES

As in any high speed analog circuitry, the power supply pins are vulnerable to random noise. To achieve optimum jitter performance, power supply isolation is required. The 873991-147 provides separate power supplies to isolate any high switching noise from the outputs to the internal PLL. V_{CC} , V_{CCA} , and V_{CCO} should be individually connected to the power supply plane through vias, and $0.01\mu\text{F}$ bypass capacitors should be used for each pin. *Figure 2* illustrates this for a generic V_{CC} pin and also shows that V_{CCA} requires that an additional 10Ω resistor along with a $10\mu\text{F}$ bypass capacitor be connected to the V_{CCA} pin.

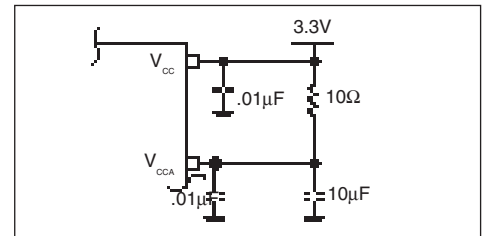

FIGURE 2. POWER SUPPLY FILTERING

WIRING THE DIFFERENTIAL INPUT TO ACCEPT SINGLE ENDED LEVELS

Figure 3 shows how the differential input can be wired to accept single ended levels. The reference voltage $V_{REF} = V_{CC}/2$ is generated by the bias resistors $R1$, $R2$ and $C1$. This bias circuit should be located as close as possible to the input pin. The ratio

of $R1$ and $R2$ might need to be adjusted to position the V_{REF} in the center of the input voltage swing. For example, if the input clock swing is only 2.5V and $V_{CC} = 3.3\text{V}$, V_{REF} should be 1.25V and $R2/R1 = 0.609$.

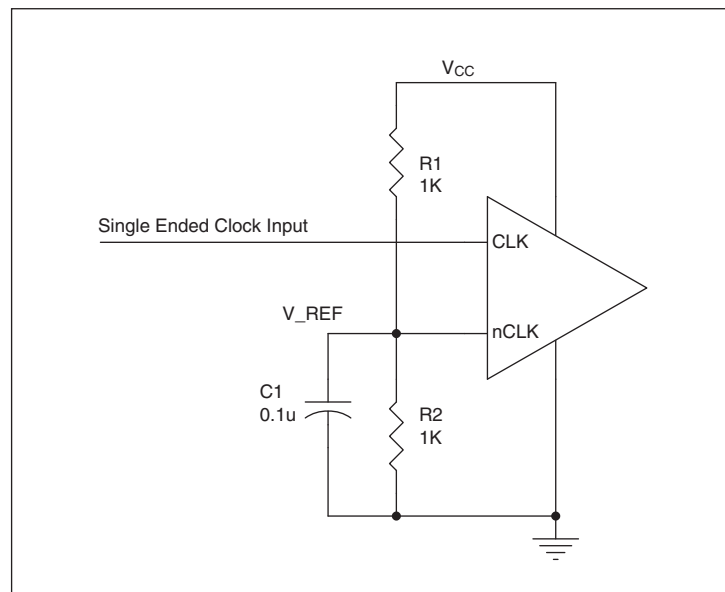

FIGURE 3. SINGLE ENDED SIGNAL DRIVING DIFFERENTIAL INPUT

DIFFERENTIAL CLOCK INPUT INTERFACE

The CLK/nCLK accepts LVDS, LVPECL, LVHSTL, SSTL, HCSL and other differential signals. Both V_{SWING} and V_{OH} must meet the V_{PP} and V_{CMR} input requirements. Figures 4A to 4F show interface examples for the HiPerClockS CLK/nCLK input driven by the most common driver types. The input interfaces suggested here are examples only.

Please consult with the vendor of the driver component to confirm the driver termination requirements. For example in Figure 4A, the input termination applies for IDT HiPerClockS open emitter LVHSTL drivers. If you are using an LVHSTL driver from another vendor, use their termination recommendation.

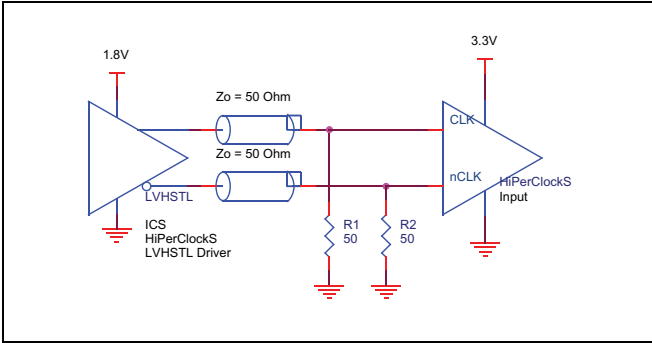

FIGURE 4A. HiPerClockS CLK/nCLK INPUT DRIVEN BY AN IDT OPEN EMITTER HiPerClockS LVHSTL DRIVER

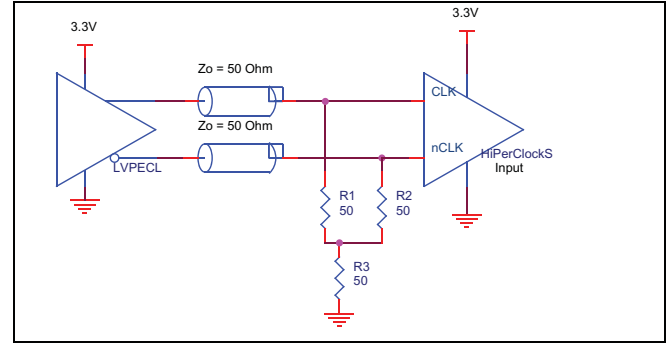

FIGURE 4B. HiPerClockS CLK/nCLK INPUT DRIVEN BY A 3.3V LVPECL DRIVER

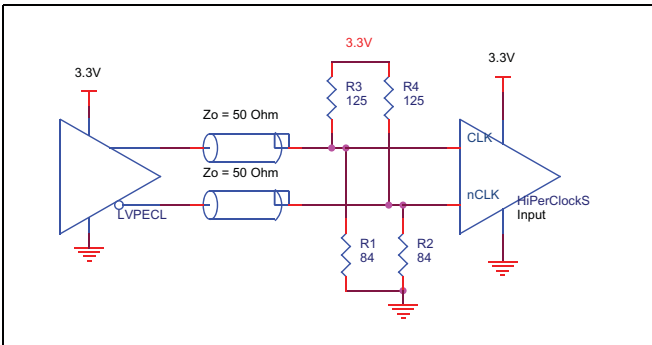

FIGURE 4C. HiPerClockS CLK/nCLK INPUT DRIVEN BY A 3.3V LVPECL DRIVER

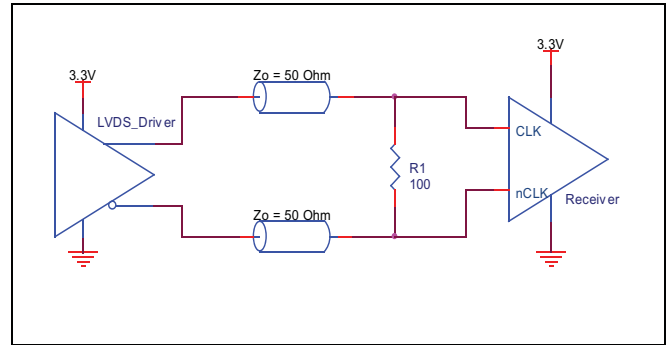

FIGURE 4D. HiPerClockS CLK/nCLK INPUT DRIVEN BY A 3.3V LVDS DRIVER

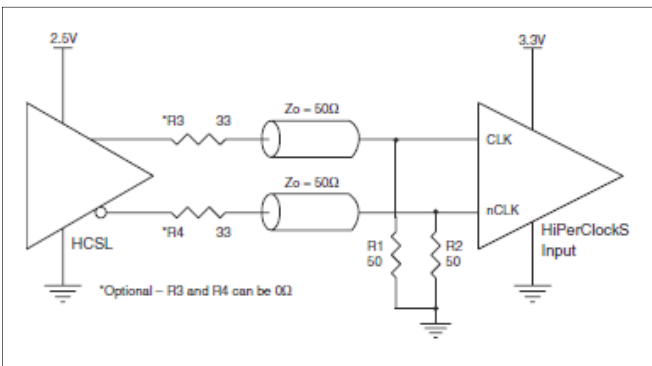

FIGURE 4E. HiPerClockS CLK/nCLK INPUT DRIVEN BY A 3.3V HCSL DRIVER

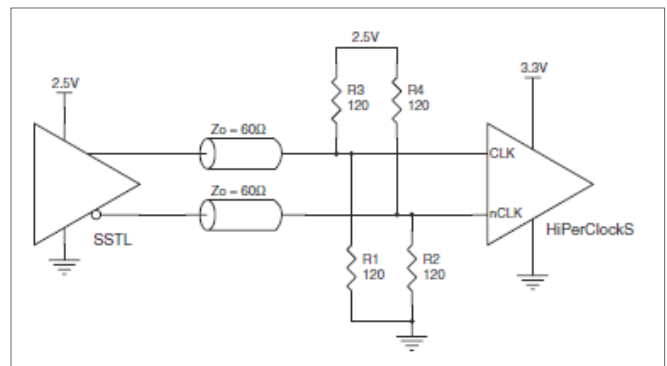

FIGURE 4F. HiPerClockS CLK/nCLK INPUT DRIVEN BY A 2.5V SSTL DRIVER

RECOMMENDATIONS FOR UNUSED INPUT AND OUTPUT PINS

INPUTS:

CLK/nCLK INPUTS

For applications not requiring the use of a differential input, both the CLK and nCLK pins can be left floating. Though not required, but for additional protection, a 1kΩ resistor can be tied from CLK to ground.

LVC MOS CONTROL PINS

All control pins have internal pullups or pulldowns; additional resistance is not required but can be added for additional protection. A 1kΩ resistor can be used.

OUTPUTS:

LVPECL OUTPUTS

All unused LVPECL outputs can be left floating. We recommend that there is no trace attached. Both sides of the differential output pair should either be left floating or terminated.

TERMINATION FOR LVPECL OUTPUTS

The clock layout topology shown below is a typical termination for LVPECL outputs. The two different layouts mentioned are recommended only as guidelines.

FOUT and nFOUT are low impedance follower outputs that generate ECL/LVPECL compatible outputs. Therefore, terminating resistors (DC current path to ground) or current sources must be used for functionality. These outputs are designed to drive 50Ω transmission

lines. Matched impedance techniques should be used to maximize operating frequency and minimize signal distortion. *Figures 5A and 5B* show two different layouts which are recommended only as guidelines. Other suitable clock layouts may exist and it would be recommended that the board designers simulate to guarantee compatibility across all printed circuit and clock component process variations.

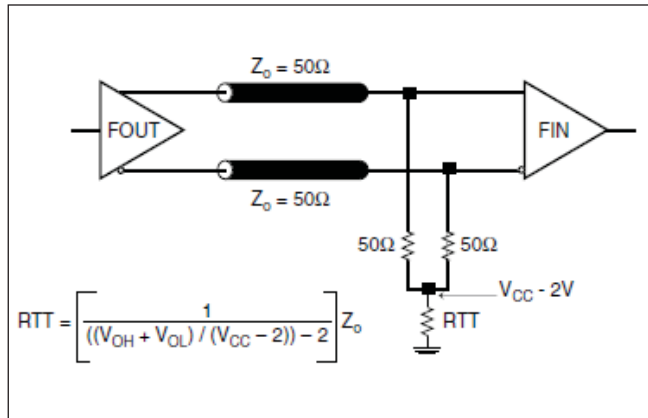

FIGURE 5A. LVPECL OUTPUT TERMINATION

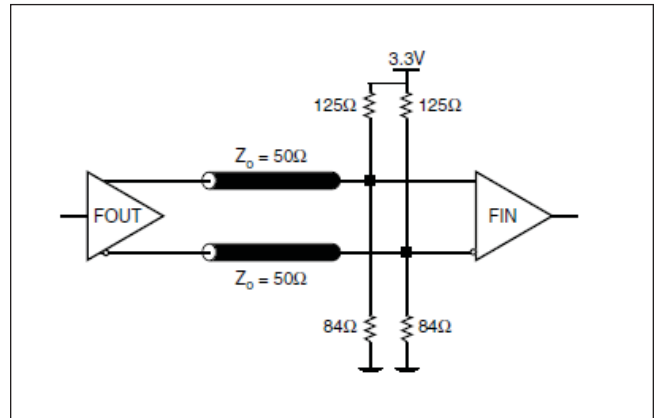

FIGURE 5B. LVPECL OUTPUT TERMINATION

Schematic Layout

Figure 6 shows an example of 873991-147 application schematic. In this example, the device is operated at $V_{CC} = V_{CCO} = 3.3V$. The decoupling capacitor should be located as close as possible to the power pin. The device are be

driven by LVPECL sources. For the LVPECL output drivers, only two termination examples are shown in this schematic. Additional termination approaches are shown in the LVPECL Termination Application Note.

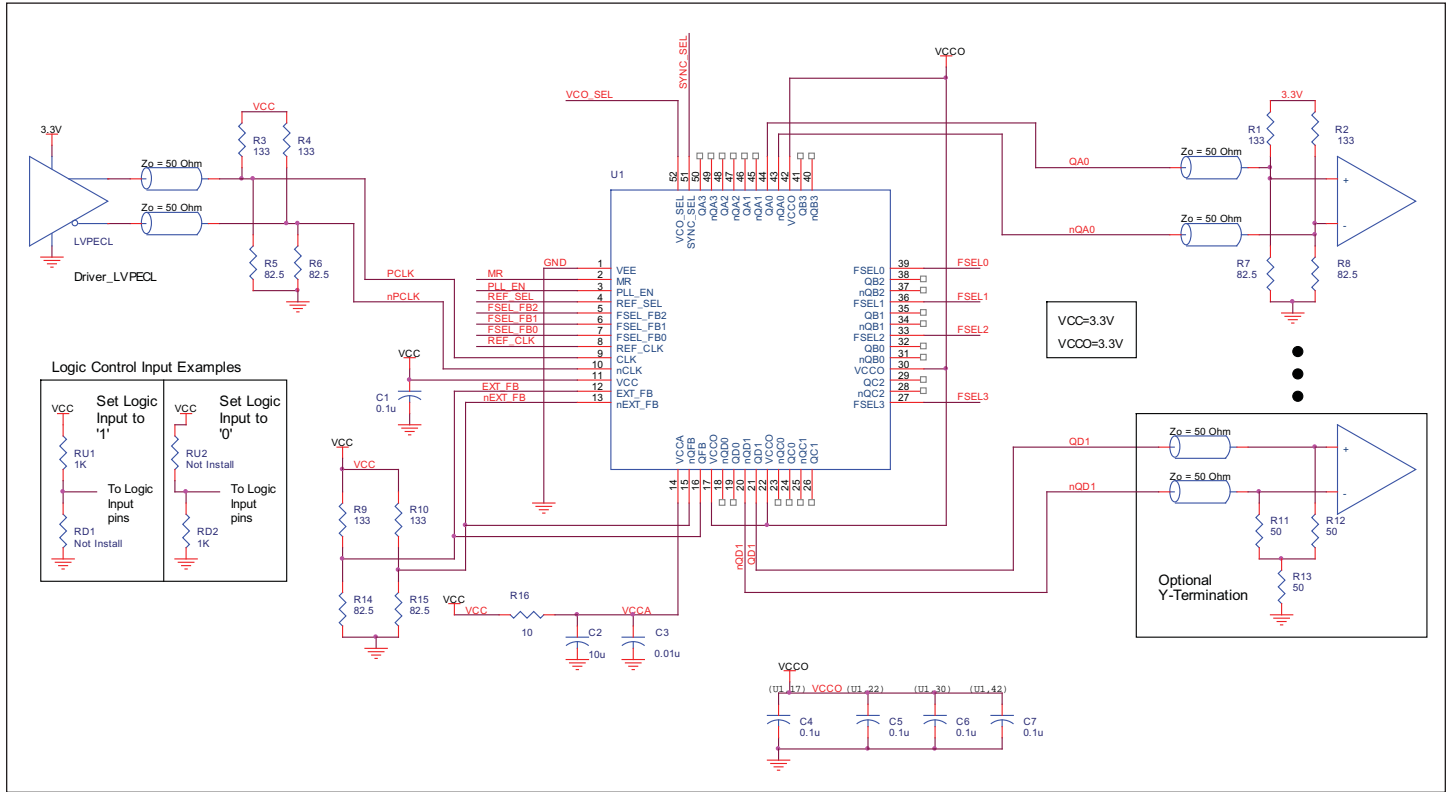

FIGURE 6. 873991-147 SCHMATIC LAYOUT

POWER CONSIDERATIONS

This section provides information on power dissipation and junction temperature for the 873991-147. Equations and example calculations are also provided.

1. Power Dissipation.

The total power dissipation for the 873991-147 is the sum of the core power plus the analog power plus the power dissipated in the load(s). The following is the power dissipation for $V_{CC} = 3.3V + 5\% = 3.465V$, which gives worst case results.

NOTE: Please refer to Section 3 for details on calculating power dissipated in the load.

- Power (core)_{MAX} = $V_{CC,MAX} * (I_{CC,MAX} + I_{CCA,MAX} + I_{CCO,MAX}) = 3.465V * (150mA + 15mA + 95mA) = 900.9mW$
- Power (outputs)_{MAX} = **30mW/Loaded Output pair**
If all outputs are loaded, the total power is $14 * 30mW = 420mW$

Total Power_{MAX} (3.465V, with all outputs switching) = $900.9mW + 420mW = 1.3209W$

2. Junction Temperature.

Junction temperature, T_J, is the temperature at the junction of the bond wire and bond pad and directly affects the reliability of the device. The maximum recommended junction temperature for HiPerClockS™ devices is 125°C.

The equation for T_J is as follows: $T_J = \theta_{JA} * Pd_total + T_A$

T_J = Junction Temperature

θ_{JA} = Junction-to-Ambient Thermal Resistance

Pd_{total} = Total Device Power Dissipation (example calculation is in section 1 above)

T_A = Ambient Temperature

In order to calculate junction temperature, the appropriate junction-to-ambient thermal resistance θ_{JA} must be used. Assuming no air flow and a multi-layer board, the appropriate value is 55.5°C/W per Table 7 below.

Therefore, T_J for an ambient temperature of 50°C with all outputs switching is:

$$50^\circ\text{C} + 1.32\text{W} * 55.5^\circ\text{C}/\text{W} = 123.3^\circ\text{C}. \text{ This is at the limit of } 125^\circ\text{C}.$$

This calculation is only an example. T_J will obviously vary depending on the number of loaded outputs, supply voltage, air flow, and the type of board (multi-layer).

TABLE 7. THERMAL RESISTANCE θ_{JA} FOR 52-PIN LQFP FORCED CONVECTION

	θ_{JA} by Velocity (Meters per Second)		
	0	1	2.5
Multi-Layer PCB, JEDEC Standard Test Boards	55.5°C/W	50.1°C/W	47.0°C/W

3. Calculations and Equations.

The purpose of this section is to derive the power dissipated into the load.

LVPECL output driver circuit and termination are shown in Figure 7

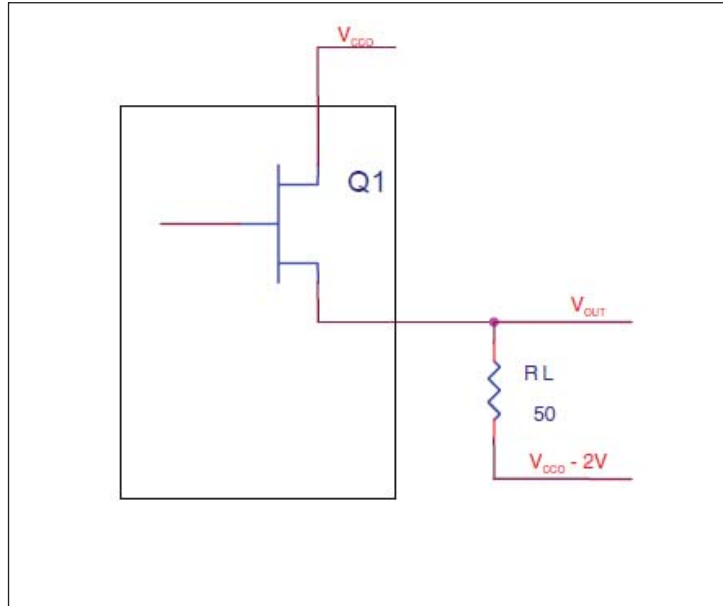

FIGURE 7. LVPECL DRIVER CIRCUIT AND TERMINATION

To calculate worst case power dissipation into the load, use the following equations which assume a 50Ω load, and a termination voltage of $V_{CCO} - 2V$.

- For logic high, $V_{OUT} = V_{OH_MAX} = V_{CCO_MAX} - 0.9V$
 $(V_{CCO_MAX} - V_{OH_MAX}) = 0.9V$
- For logic low, $V_{OUT} = V_{OL_MAX} = V_{CCO_MAX} - 1.7V$
 $(V_{CCO_MAX} - V_{OL_MAX}) = 1.7V$

Pd_H is power dissipation when the output drives high.
 Pd_L is the power dissipation when the output drives low.

$$Pd_H = [(V_{OH_MAX} - (V_{CCO_MAX} - 2V))/R_L] * (V_{CCO_MAX} - V_{OH_MAX}) = [(2V - (V_{CCO_MAX} - V_{OH_MAX}))/R_L] * (V_{CCO_MAX} - V_{OH_MAX}) = [(2V - 0.9V)/50\Omega] * 0.9V = 19.8mW$$

$$Pd_L = [(V_{OL_MAX} - (V_{CCO_MAX} - 2V))/R_L] * (V_{CCO_MAX} - V_{OL_MAX}) = [(2V - (V_{CCO_MAX} - V_{OL_MAX}))/R_L] * (V_{CCO_MAX} - V_{OL_MAX}) = [(2V - 1.7V)/50\Omega] * 1.7V = 10.2mW$$

Total Power Dissipation per output pair = Pd_H + Pd_L = 30mW

RELIABILITY INFORMATION

TABLE 8. θ_{JA} vs. AIR FLOW TABLE FOR 52 LEAD LQFP

θ_{JA} by Velocity (Meters per Second)			
	0	1	2.5
Multi-Layer PCB, JEDEC Standard Test Boards	55.5°C/W	50.1°C/W	47.0°C/W

TRANSISTOR COUNT

The transistor count for 873991-147 is: 5969

PACKAGE OUTLINE - Y SUFFIX FOR 52 LEAD LQFP

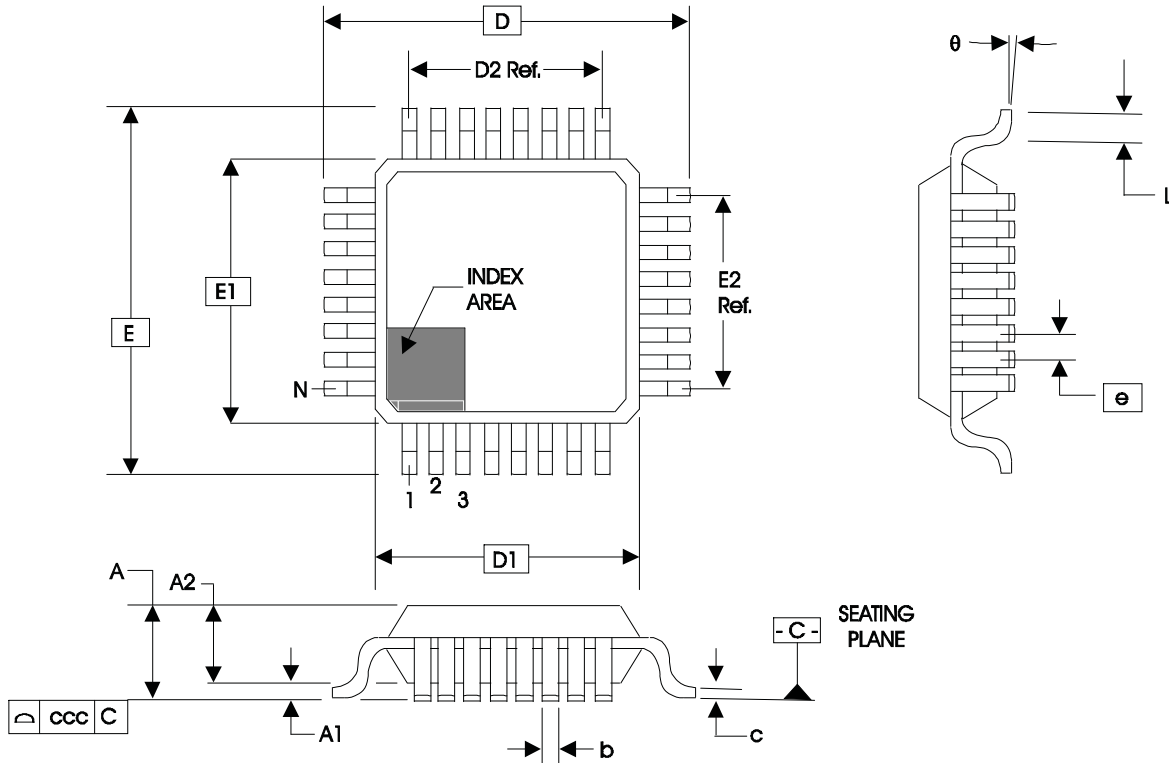

TABLE 9. PACKAGE DIMENSIONS

JEDEC VARIATION ALL DIMENSIONS IN MILLIMETERS			
SYMBOL	BCC		
	MINIMUM	NOMINAL	MAXIMUM
N	52		
A	--	--	1.60
A1	0.05	--	0.15
A2	1.35	1.40	1.45
b	0.22	0.32	0.38
c	0.09	--	0.20
D	12.00 BASIC		
D1	10.00 BASIC		
D2	7.80 Ref.		
E	12.00 BASIC		
E1	10.00 BASIC		
E2	7.80 Ref.		
e	0.65 BASIC		
L	0.45	--	0.75
θ	0°	--	7°
ccc	--	--	0.10

Reference Document: JEDEC Publication 95, MS-026

TABLE 10. ORDERING INFORMATION

Part/Order Number	Marking	Package	Shipping Packaging	Temperature
873991AY-147LF	ICS873991A147L	52 Lead "Lead-Free" LQFP	tray	0°C to 50°C
873991AY-147LFT	ICS873991A147L	52 Lead "Lead-Free" LQFP	tape & reel	0°C to 50°C

NOTE: Parts that are ordered with an "LF" suffix to the part number are the Pb-Free configuration and are RoHS compliant.

REVISION HISTORY SHEET

Rev	Table	Page	Description of Change	Date
A	T6	8	AC Characteristics Table - corrected symbol for Half Cycle Jitter. Power Considerations - corrected I_{EE_MAX} from 150mA to 165mA and recalculated equations. Deleted the word Preliminary from inside page headers.	11/18/08
B	T4A T4C T4D T6 T8	6 7 7 8 11 13 14 16	Changed from 0°C to 70°C to 0°C to 50°C throughout the datasheet. Changed PCLK/nPCLK to CLK/nCLK throughout the datasheet. Power Supply DC Characteristics Table - changed V_{CCA} from 3.135V min to $V_{CC} - 0.15V$ and 3.465V max. to V_{CC} . Added Differential DC Characteristics Table for CLK/nCLK and EXT_FB/nEXT_FB inputs. Updated LVPECL DC Characteristics Table for LVPECL outputs. AC Characteristics Table - corrected Half-Cycle Jitter symbol from $t_{jit}(hper)$ to $t_{jit}(hcyc)$. Updated Differential Clock Input Interface section. Added Schematic Layout. Power Considerations - corrected I_{EE_MAX} from 165mA to 260mA, updated Thermal Resistance values in Table 7, and recalculated equations. Air Flow Table - updated the values.	3/31/09
B			Product Discontinuation Notice - Last time buy expires August 14, 2016. PDN CQ-15-04	8/25/15

IMPORTANT NOTICE AND DISCLAIMER

RENESAS ELECTRONICS CORPORATION AND ITS SUBSIDIARIES (“RENESAS”) PROVIDES TECHNICAL SPECIFICATIONS AND RELIABILITY DATA (INCLUDING DATASHEETS), DESIGN RESOURCES (INCLUDING REFERENCE DESIGNS), APPLICATION OR OTHER DESIGN ADVICE, WEB TOOLS, SAFETY INFORMATION, AND OTHER RESOURCES “AS IS” AND WITH ALL FAULTS, AND DISCLAIMS ALL WARRANTIES, EXPRESS OR IMPLIED, INCLUDING, WITHOUT LIMITATION, ANY IMPLIED WARRANTIES OF MERCHANTABILITY, FITNESS FOR A PARTICULAR PURPOSE, OR NON-INFRINGEMENT OF THIRD-PARTY INTELLECTUAL PROPERTY RIGHTS.

These resources are intended for developers who are designing with Renesas products. You are solely responsible for (1) selecting the appropriate products for your application, (2) designing, validating, and testing your application, and (3) ensuring your application meets applicable standards, and any other safety, security, or other requirements. These resources are subject to change without notice. Renesas grants you permission to use these resources only to develop an application that uses Renesas products. Other reproduction or use of these resources is strictly prohibited. No license is granted to any other Renesas intellectual property or to any third-party intellectual property. Renesas disclaims responsibility for, and you will fully indemnify Renesas and its representatives against, any claims, damages, costs, losses, or liabilities arising from your use of these resources. Renesas' products are provided only subject to Renesas' Terms and Conditions of Sale or other applicable terms agreed to in writing. No use of any Renesas resources expands or otherwise alters any applicable warranties or warranty disclaimers for these products.

(Disclaimer Rev.1.01 Jan 2024)

Corporate Headquarters

TOYOSU FORESIA, 3-2-24 Toyosu,
Koto-ku, Tokyo 135-0061, Japan
www.renesas.com

Trademarks

Renesas and the Renesas logo are trademarks of Renesas Electronics Corporation. All trademarks and registered trademarks are the property of their respective owners.

Contact Information

For further information on a product, technology, the most up-to-date version of a document, or your nearest sales office, please visit www.renesas.com/contact-us/.