

General Description

The ICS8305 is a low skew, 1-to-4, Differential/ LVCMOS-to-LVCMOS/LVTTL Fanout Buffer. The ICS8305 has selectable clock inputs that accept either differential or single ended input levels. The clock enable is internally synchronized to eliminate runt pulses on the outputs during asynchronous assertion/deassertion of the clock enable pin. Outputs are forced LOW when the clock is disabled. A separate output enable pin controls whether the outputs are in the active or high impedance state.

Guaranteed output and part-to-part skew characteristics make the ICS8305 ideal for those applications demanding well defined performance and repeatability.

Features

- Four LVCMOS / LVTTL outputs, 7Ω output impedance
- Selectable differential or LVCMOS / LVTTL clock inputs
- CLK, nCLK pair can accept the following differential input levels: LVPECL, LVDS, LVHSTL, HCSL, SSTL
- LVCMOS_CLK supports the following input types: LVCMOS, LVTTL
- Maximum output frequency: 350MHz
- Output skew: 35ps (maximum)
- Part-to-part skew: 700ps (maximum)
- Additive phase jitter, RMS: 0.04ps (typical)
- Power supply modes:
Core/Output
3.3V/3.3V
3.3V/2.5V
3.3V/1.8V
3.3V/1.5V
- 0°C to 70°C ambient operating temperature
- Available in lead-free (RoHS 6) package

Block Diagram

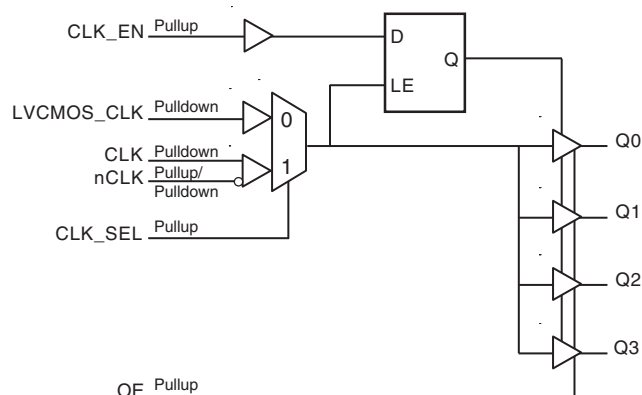

Pin Assignment

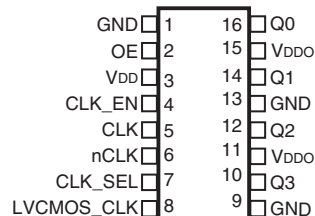

ICS8305
16-Lead TSSOP
4.4mm x 3.0mm x 0.925mm package body
G Package
Top View

Table 1. Pin Descriptions

| Number | Name | Type | | Description |
|----------------|------------------|--------|---------------------|--|
| 1, 9, 13 | GND | Power | | Power supply ground |
| 2 | OE | Input | Pullup | Output enable. When LOW, outputs are in HIGH impedance state. When HIGH, outputs are active. LVCMOS/LVTTL interface levels. |
| 3 | V _{DD} | Power | | Power supply pin. |
| 4 | CLK_EN | Input | Pullup | Synchronizing clock enable. When LOW, the output clocks are disabled. When HIGH, output clocks are enabled. LVCMOS/LVTTL interface levels. |
| 5 | CLK | Input | Pulldown | Non-inverting differential clock input. |
| 6 | nCLK | Input | Pullup/ Pulldown | Inverting differential clock input. VDD/2 default when left floating. |
| 7 | CLK_SEL | Input | Pullup | Clock select input. When HIGH, selects CLK, nCLK inputs. When LOW, selects LVCMOS_CLK input. LVCMOS/LVTTL interface levels. |
| 8 | LVCMOS_CLK | Input | Pulldown | Single-ended clock input. LVCMOS/LVTTL interface levels. |
| 10, 12, 14, 16 | Q3, Q2, Q1, Q0 | Output | | Single-ended clock outputs. 7Ω output impedance. LVCMOS/LVTTL interface levels. |
| 11, 15 | V _{DDO} | Power | | Output supply pins. |

NOTE: *Pullup and Pulldown* refer to internal input resistors. See Table 2, *Pin Characteristics*, for typical values.

Table 2. Pin Characteristics

| Symbol | Parameter | Test Conditions | Minimum | Typical | Maximum | Units |
|-----------------------|--|-----------------|---------|---------|---------|-------|
| C _{IN} | Input Capacitance | | | 4 | | pF |
| R _{PULLUP} | Input Pullup Resistor | | | 51 | | kΩ |
| R _{PULLDOWN} | Input Pulldown Resistor | | | 51 | | kΩ |
| C _{PD} | Power Dissipation Capacitance (per output) | | | 11 | | pF |
| R _{OUT} | Output Impedance | | | 7 | | Ω |

Function Tables

Table 3. Control Input Function Table

| Inputs | | | | Outputs |
|--------|--------|---------|-----------------|---------------|
| OE | CLK_EN | CLK_SEL | Selected Source | Q0:Q3 |
| 1 | 0 | 0 | LVC MOS_CLK | Disabled; Low |
| 1 | 0 | 1 | CLK/nCLK | Disabled; Low |
| 1 | 1 | 0 | LVC MOS_CLK | Enabled |
| 1 | 1 | 1 | CLK/nCLK | Enabled |
| 0 | X | X | | Hi-Z |

After CLK_EN switches, the clock outputs are disabled or enabled following a rising and falling input clock edge as shown in Figure 1.

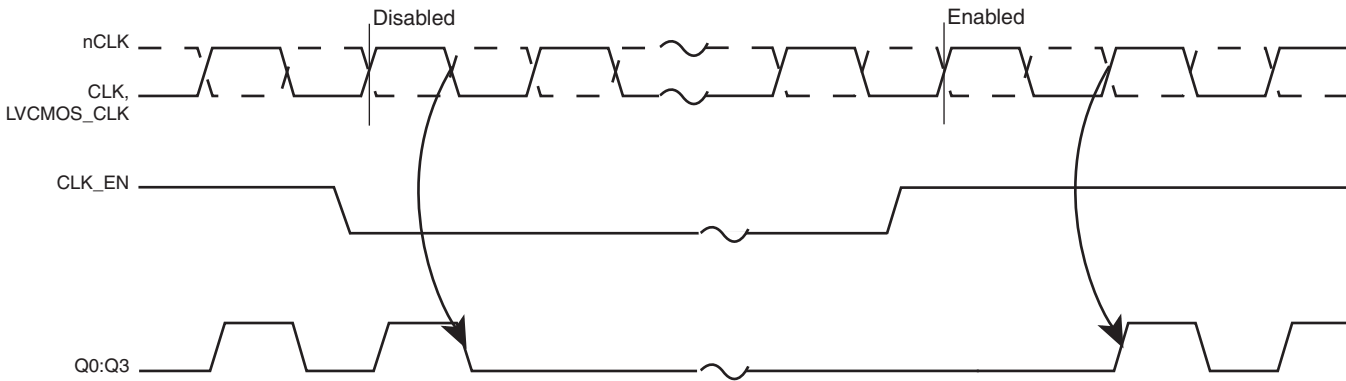

Figure 1. CLK_EN Timing Diagram

Absolute Maximum Ratings

NOTE: Stresses beyond those listed under *Absolute Maximum Ratings* may cause permanent damage to the device. These ratings are stress specifications only. Functional operation of product at these conditions or any conditions beyond those listed in the *DC Characteristics* or *AC Characteristics* is not implied. Exposure to absolute maximum rating conditions for extended periods may affect product reliability.

| Item | Rating |
|--|---------------------------|
| Supply Voltage, V_{DD} | 4.6V |
| Inputs, V_I | -0.5V to $V_{DD} + 0.5V$ |
| Outputs, V_O | -0.5V to $V_{DDO} + 0.5V$ |
| Package Thermal Impedance, θ_{JA} | 89°C/W (0 lfm) |
| Storage Temperature, T_{STG} | -65°C to 150°C |

DC Electrical Characteristics

Table 4A. Power Supply DC Characteristics, $V_{DD} = 3.3V \pm 5\%$, $V_{DDO} = 3.3V \pm 5\%$ or $2.5V \pm 5\%$ or $1.8V \pm 0.5V$ or $1.5V \pm 5\%$, $T_A = 0^\circ\text{C}$ to 70°C

| Symbol | Parameter | Test Conditions | Minimum | Typical | Maximum | Units |
|-----------|-------------------------|-----------------|---------|---------|---------|-------|
| V_{DD} | Positive Supply Voltage | | 3.135 | 3.3 | 3.465 | V |
| V_{DDO} | Output Supply Voltage | | 3.135 | 3.3 | 3.465 | V |
| | | | 2.375 | 2.5 | 2.625 | V |
| | | | 1.65 | 1.8 | 1.95 | V |
| | | | 1.425 | 1.5 | 1.575 | V |
| I_{DD} | Power Supply Current | | | | 21 | mA |
| I_{DDO} | Output Supply Current | | | | 5 | mA |

Table 4B. LVCMOS/LVTTL DC Characteristics, $T_A = 0^\circ\text{C}$ to 70°C

| Symbol | Parameter | Test Conditions | Minimum | Typical | Maximum | Units |
|-----------|-----------------------------|---------------------|--|-----------------|----------------|---------------|
| V_{IH} | Input High Voltage | CLK_EN, CLK_SEL, OE | 2 | | $V_{DD} + 0.3$ | V |
| | | LVCOSMOS_CLK | 2 | | $V_{DD} + 0.3$ | V |
| V_{IL} | Input Low Voltage | CLK_EN, CLK_SEL, OE | -0.3 | | 0.8 | V |
| | | LVCOSMOS_CLK | -0.3 | | 1.3 | V |
| I_{IH} | Input High Current | CLK_EN, CLK_SEL, OE | $V_{DD} = V_{IN} = 3.465\text{V}$ | | 5 | μA |
| | | LVCOSMOS_CLK | $V_{DD} = V_{IN} = 3.465\text{V}$ | | 150 | μA |
| I_{IL} | Input Low Current | CLK_EN, CLK_SEL, OE | $V_{DD} = 3.465\text{V}, V_{IN} = 0\text{V}$ | -150 | | μA |
| | | LVCOSMOS_CLK | $V_{DD} = 3.465\text{V}, V_{IN} = 0\text{V}$ | -5 | | μA |
| V_{OH} | Output High Voltage; NOTE 1 | | $V_{DDO} = 3.3\text{V} \pm 5\%$ | 2.6 | | V |
| | | | $V_{DDO} = 2.5\text{V} \pm 5\%$ | 1.8 | | V |
| | | | $V_{DDO} = 1.8\text{V} \pm 0.15\text{V}$ | 1.5 | | V |
| | | | $V_{DDO} = 1.5\text{V} \pm 5\%$ | $V_{DDO} - 0.3$ | | V |
| V_{OL} | Output Low Voltage; NOTE 1 | | $V_{DDO} = 3.3\text{V} \pm 5\%$ | | 0.5 | V |
| | | | $V_{DDO} = 2.5\text{V} \pm 5\%$ | | 0.5 | V |
| | | | $V_{DDO} = 1.8\text{V} \pm 0.15\text{V}$ | | 0.4 | V |
| | | | $V_{DDO} = 1.5\text{V} \pm 5\%$ | | 0.35 | V |
| I_{OZL} | Output Hi-Z Current Low | | -5 | | | μA |
| I_{OZH} | Output Hi-Z Current High | | | | 5 | μA |

NOTE 1: Outputs terminated with 50Ω to $V_{DDO}/2$. See Parameter Measurement Information, *Output Load Test Circuit diagrams*.

Table 4C. Differential DC Characteristics, $T_A = -40^\circ\text{C}$ to 85°C

| Symbol | Parameter | Test Conditions | Minimum | Typical | Maximum | Units |
|-----------|--------------------------------------|-----------------|--|---------|-----------------|---------------|
| I_{IH} | Input High Current | nCLK | $V_{DD} = V_{IN} = 3.465\text{V}$ | | 150 | μA |
| | | CLK | $V_{DD} = V_{IN} = 3.465\text{V}$ | | 150 | μA |
| I_{IL} | Input Low Current | nCLK | $V_{DD} = 3.465\text{V}, V_{IN} = 0\text{V}$ | -150 | | μA |
| | | CLK | $V_{DD} = 3.465\text{V}, V_{IN} = 0\text{V}$ | -5 | | μA |
| V_{PP} | Peak-to-Peak Voltage; NOTE 1 | | 0.15 | | 1.3 | V |
| V_{CMR} | Common Mode Input Voltage; NOTE 1, 2 | | GND + 0.5 | | $V_{DD} - 0.85$ | V |

NOTE 1: V_{IL} should not be less than -0.3V.

NOTE 2: Common mode input voltage is defined as V_{IH} .

AC Electrical Characteristics

Table 5A. AC Characteristics, $V_{DD} = V_{DDO} = 3.3V \pm 5\%$, $T_A = 0^\circ C$ to $70^\circ C$

| Parameter | Symbol | Test Conditions | Minimum | Typical | Maximum | Units |
|--------------|---|---|---------|---------|---------|-------|
| f_{MAX} | Output Frequency | | | | 350 | MHz |
| t_{PLH} | Propagation Delay, Low to High | LVC MOS_CLK; NOTE 1A CLK/nCLK; NOTE 1B | 1.75 | | 2.75 | ns |
| $t_{sk(o)}$ | Output Skew; NOTE 2, 6 | Measured on the Rising Edge | | | 35 | ps |
| $t_{sk(pp)}$ | Part-to-Part Skew; NOTE 3, 6 | | | | 700 | ps |
| t_{jit} | Buffer Additive Phase Jitter, RMS; refer to Additive Phase Jitter Section, NOTE 5 | | | 0.04 | | ps |
| t_R / t_F | Output Rise/Fall Time; NOTE 4 | 20% to 80% | 100 | | 700 | ps |
| odc | Output Duty Cycle | Ref = CLK/nCLK | 45 | | 55 | % |
| | | Ref = LVC MOS_CLK, $f \leq 300MHz$ | 45 | | 55 | % |
| t_{EN} | Output Enable Time; NOTE 4 | | | | 5 | ns |
| t_{DIS} | Output Disable Time; NOTE 4 | | | | 5 | ns |

NOTE: Electrical parameters are guaranteed over the specified ambient operating temperature range, which is established when the device is mounted in a test socket with maintained transverse airflow greater than 500 lpm. The device will meet specifications after thermal equilibrium has been reached under these conditions.

All parameters measured at $f \leq 350MHz$ unless noted otherwise.

NOTE 1A: Measured from the $V_{DD}/2$ of the input to $V_{DDO}/2$ of the output.

NOTE 1B: Measured from the differential input crossing point to $V_{DDO}/2$ of the output.

NOTE 2: Defined as skew between outputs at the same supply voltage and with equal load conditions. Measured at $V_{DDO}/2$.

NOTE 3: Defined as skew between outputs on different devices operating at the same supply voltages and with equal load conditions. Using the same type of input on each device, the output is measured at $V_{DDO}/2$.

NOTE 4: These parameters are guaranteed by characterization. Not tested in production.

NOTE 5: Driving only one input clock.

NOTE 6: This parameter is defined in accordance with JEDEC Standard 65.

Table 5B. AC Characteristics, $V_{DD} = 3.3V \pm 5\%$, $V_{DDO} = 2.5V \pm 5\%$, $T_A = 0^\circ C$ to $70^\circ C$

| Parameter | Symbol | Test Conditions | Minimum | Typical | Maximum | Units |
|--------------|---|---|---------|---------|---------|-------|
| f_{MAX} | Output Frequency | | | | 350 | MHz |
| t_{PLH} | Propagation Delay, Low to High | LVC MOS_CLK; NOTE 1A CLK/nCLK; NOTE 1B | 1.8 | | 2.9 | ns |
| $t_{sk(o)}$ | Output Skew; NOTE 2, 6 | Measured on the Rising Edge | | | 35 | ps |
| $t_{sk(pp)}$ | Part-to-Part Skew; NOTE 3, 6 | | | | 800 | ps |
| t_{jit} | Buffer Additive Phase Jitter, RMS; refer to Additive Phase Jitter Section, NOTE 5 | | | 0.04 | | ps |
| t_R / t_F | Output Rise/Fall Time; NOTE 4 | 20% to 80% | 100 | | 700 | ps |
| odc | Output Duty Cycle | Ref = CLK/nCLK | 44 | | 56 | % |
| | | Ref = LVC MOS_CLK, $f \leq 300MHz$ | 44 | | 56 | % |
| t_{EN} | Output Enable Time; NOTE 4 | | | | 5 | ns |
| t_{DIS} | Output Disable Time; NOTE 4 | | | | 5 | ns |

For NOTES, see Table 5A above.

Table 5C. AC Characteristics, $V_{DD} = 3.3V \pm 5\%$, $V_{DDO} = 1.8V \pm 0.15V$, $T_A = 0^\circ C$ to $70^\circ C$

| Parameter | Symbol | Test Conditions | Minimum | Typical | Maximum | Units |
|--------------|---|---|---------|---------|---------|-------|
| f_{MAX} | Output Frequency | | | | 350 | MHz |
| t_{pLH} | Propagation Delay, Low to High | LVC MOS_CLK; NOTE 1A CLK/nCLK; NOTE 1B | 1.95 | | 3.65 | ns |
| $t_{sk(o)}$ | Output Skew; NOTE 2, 6 | Measured on the Rising Edge | | | 35 | ps |
| $t_{sk(pp)}$ | Part-to-Part Skew; NOTE 3, 6 | | | | 900 | ps |
| t_{jit} | Buffer Additive Phase Jitter, RMS; refer to Additive Phase Jitter Section, NOTE 5 | | | 0.04 | | ps |
| t_R / t_F | Output Rise/Fall Time; NOTE 4 | 20% to 80% | 100 | | 700 | ps |
| odc | Output Duty Cycle | Ref = CLK/nCLK | 44 | | 56 | % |
| | | Ref = LVC MOS_CLK, $f \leq 300MHz$ | 44 | | 56 | % |
| t_{EN} | Output Enable Time; NOTE 4 | | | | 5 | ns |
| t_{DIS} | Output Disable Time; NOTE 4 | | | | 5 | ns |

NOTE: Electrical parameters are guaranteed over the specified ambient operating temperature range, which is established when the device is mounted in a test socket with maintained transverse airflow greater than 500 lpm. The device will meet specifications after thermal equilibrium has been reached under these conditions.

All parameters measured at $f \leq 350MHz$ unless noted otherwise.

NOTE 1A: Measured from the $V_{DD}/2$ of the input to $V_{DDO}/2$ of the output.

NOTE 1B: Measured from the differential input crossing point to $V_{DDO}/2$ of the output.

NOTE 2: Defined as skew between outputs at the same supply voltage and with equal load conditions. Measured at $V_{DDO}/2$.

NOTE 3: Defined as skew between outputs on different devices operating at the same supply voltages and with equal load conditions. Using the same type of input on each device, the output is measured at $V_{DDO}/2$.

NOTE 4: These parameters are guaranteed by characterization. Not tested in production.

NOTE 5: Driving only one input clock.

NOTE 6: This parameter is defined in accordance with JEDEC Standard 65.

Table 5D. AC Characteristics, $V_{DD} = 3.3V \pm 5\%$, $V_{DDO} = 1.5V \pm 5\%$, $T_A = 0^\circ C$ to $70^\circ C$

| Parameter | Symbol | Test Conditions | Minimum | Typical | Maximum | Units |
|--------------|---|---|---------|---------|---------|-------|
| f_{MAX} | Output Frequency | | | | 350 | MHz |
| t_{pLH} | Propagation Delay, Low to High | LVC MOS_CLK; NOTE 1A CLK/nCLK; NOTE 1B | 2 | | 4 | ns |
| $t_{sk(o)}$ | Output Skew; NOTE 2, 6 | Measured on the Rising Edge | | | 35 | ps |
| $t_{sk(pp)}$ | Part-to-Part Skew; NOTE 3, 6 | | | | 1 | ns |
| t_{jit} | Buffer Additive Phase Jitter, RMS; refer to Additive Phase Jitter Section, NOTE 5 | | | 0.04 | | ps |
| t_R / t_F | Output Rise/Fall Time; NOTE 4 | 20% to 80% | 200 | | 900 | ps |
| odc | Output Duty Cycle | $f \leq 166MHz$ | 45 | | 55 | % |
| | | $f > 166MHz$ | 42 | | 58 | % |
| t_{EN} | Output Enable Time; NOTE 4 | | | | 5 | ns |
| t_{DIS} | Output Disable Time; NOTE 4 | | | | 5 | ns |

For NOTES, see Table 5C above.

Additive Phase Jitter

The spectral purity in a band at a specific offset from the fundamental compared to the power of the fundamental is called the ***dBc Phase Noise***. This value is normally expressed using a Phase noise plot and is most often the specified plot in many applications. Phase noise is defined as the ratio of the noise power present in a 1Hz band at a specified offset from the fundamental frequency to the power value of the fundamental. This ratio is expressed in decibels (dBm) or a ratio

of the power in the 1Hz band to the power in the fundamental. When the required offset is specified, the phase noise is called a ***dBc*** value, which simply means dBm at a specified offset from the fundamental. By investigating jitter in the frequency domain, we get a better understanding of its effects on the desired application over the entire time record of the signal. It is mathematically possible to calculate an expected bit error rate given a phase noise plot.

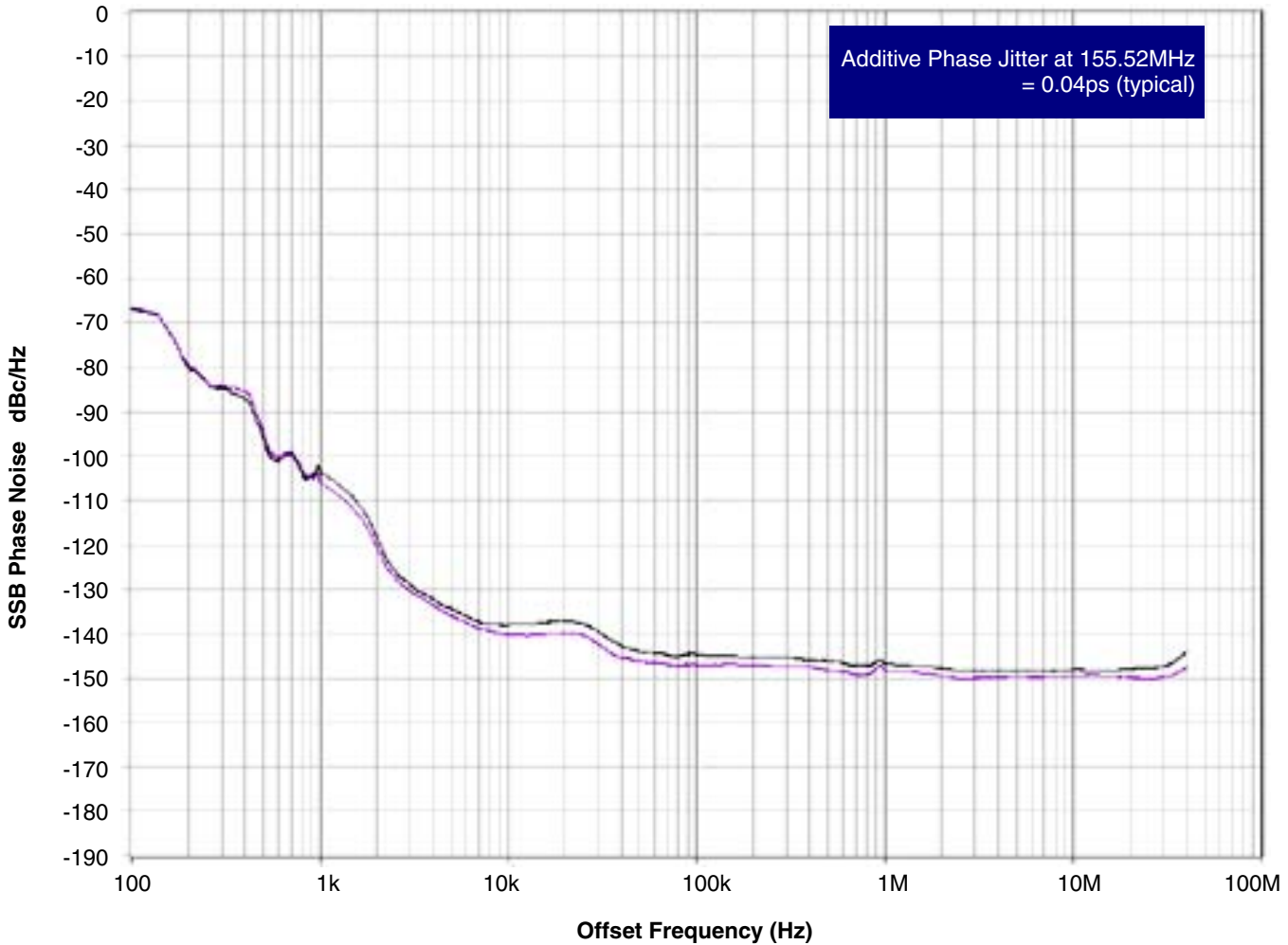

As with most timing specifications, phase noise measurements has issues relating to the limitations of the equipment. Often the noise floor of the equipment is higher than the noise floor of the device. This

is illustrated above. The device meets the noise floor of what is shown, but can actually be lower. The phase noise is dependent on the input source and measurement equipment.

Parameter Measurement Information

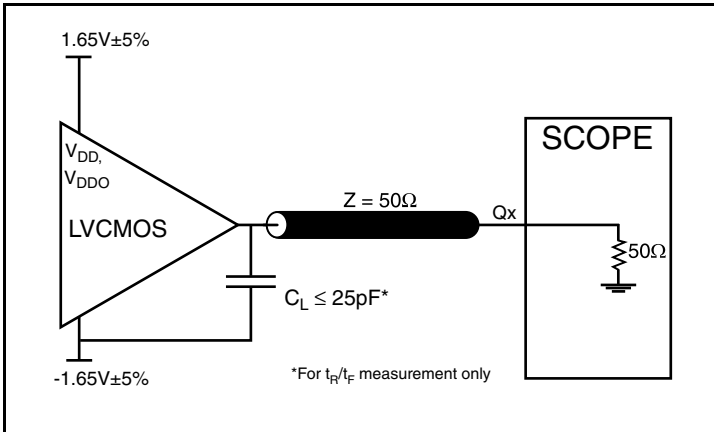

3.3V Core/3.3V LVC MOS Output Load AC Test Circuit

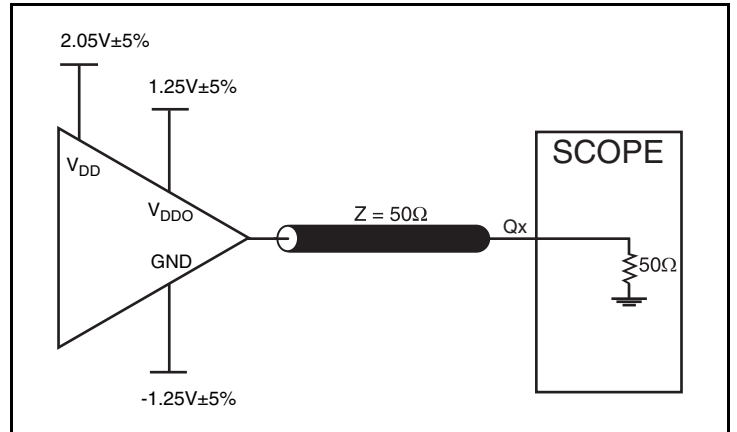

3.3V Core/2.5V LVC MOS Output Load AC Test Circuit

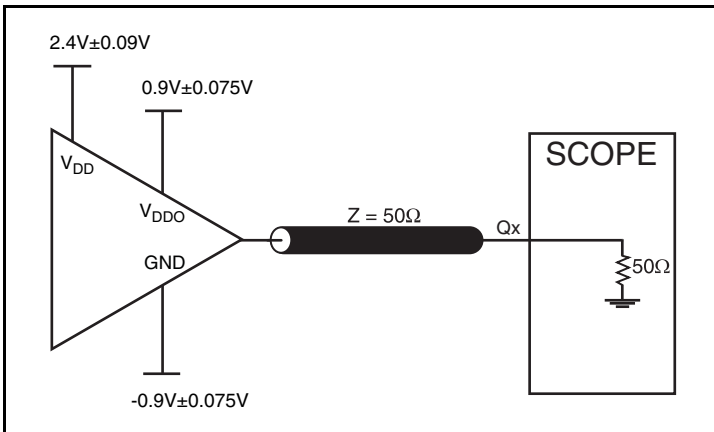

3.3V Core/1.8V LVC MOS Output Load AC Test Circuit

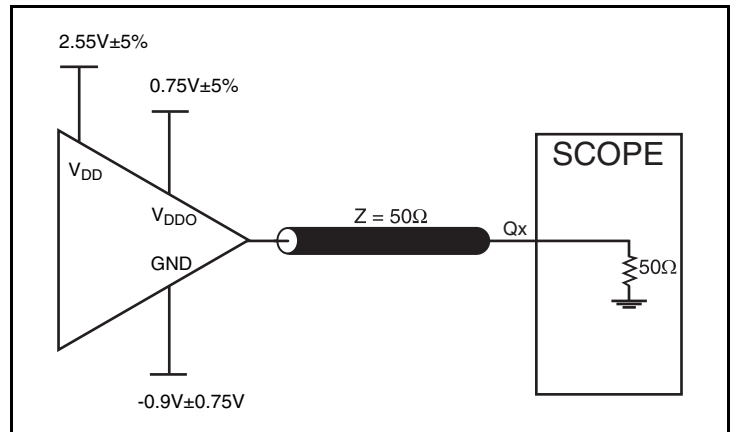

3.3V Core/1.5V LVC MOS Output Load AC Test Circuit

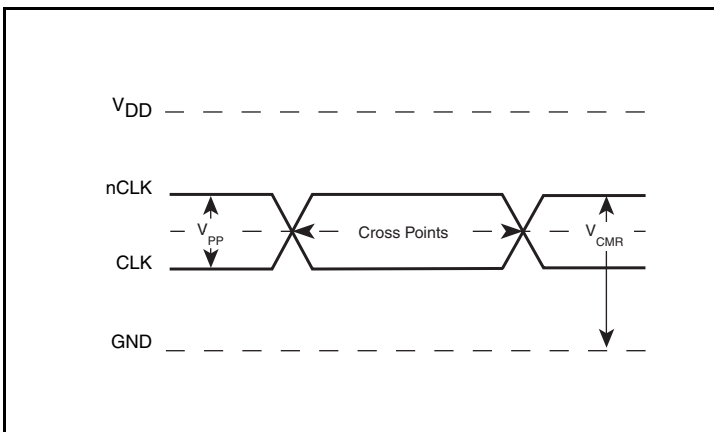

Differential Input Level

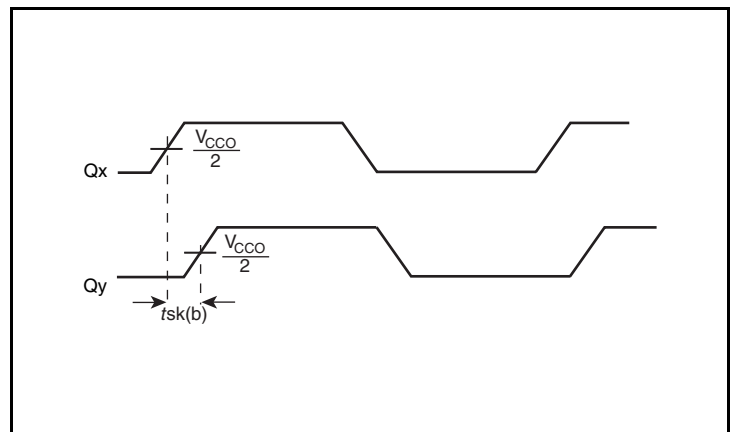

Output Skew

Parameter Measurement Information, continued

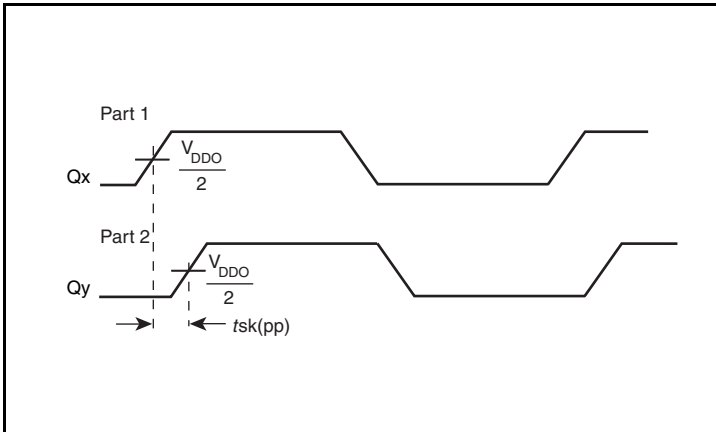

Part-to-Part Skew

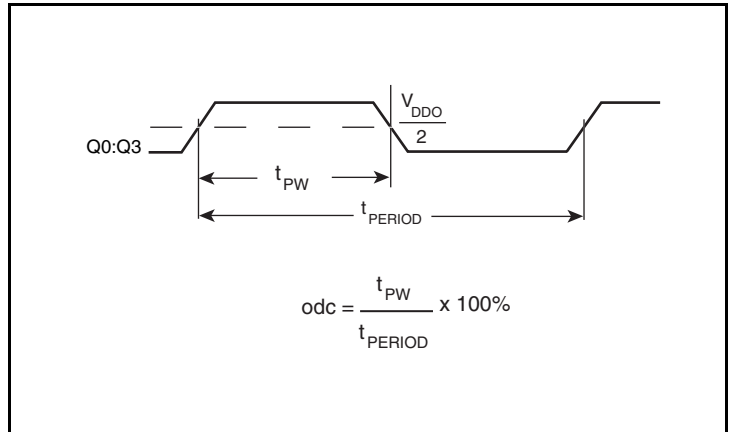

Output Duty Cycle/Pulse Width/Period

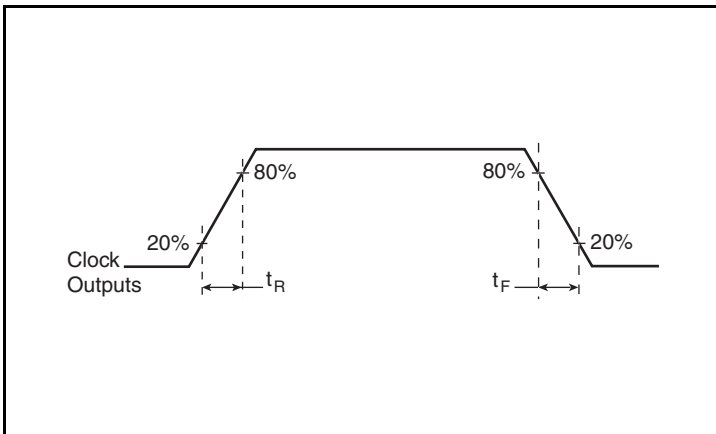

Output Rise/Fall Time

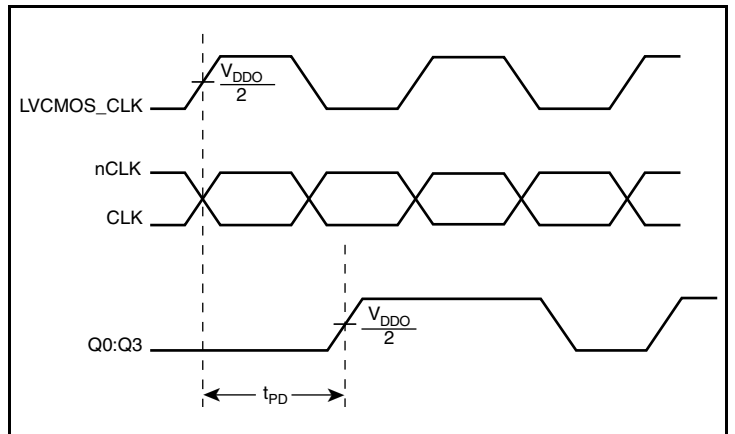

Propagation Delay

Application Information

Recommendations for Unused Input and Output Pins

Inputs:

LVC MOS_CLK Input

For applications not requiring the use of a clock input, it can be left floating. Though not required, but for additional protection, a 1kΩ resistor can be tied from the LVC MOS_CLK input to ground.

CLK/nCLK Inputs

For applications not requiring the use of the differential input, both CLK and nCLK can be left floating. Though not required, but for additional protection, a 1kΩ resistor can be tied from CLK to ground.

LVC MOS Control Pins

All control pins have internal pull-ups or pull-downs; additional resistance is not required but can be added for additional protection. A 1kΩ resistor can be used.

Outputs:

LVC MOS Outputs

All unused LVC MOS outputs can be left floating. There should be no trace attached.

Wiring the Differential Input to Accept Single Ended Levels

Figure 2 shows how a differential input can be wired to accept single ended levels. The reference voltage $V_1 = V_{DD}/2$ is generated by the bias resistors R1 and R2. The bypass capacitor (C1) is used to help filter noise on the DC bias. This bias circuit should be located as close to the input pin as possible. The ratio of R1 and R2 might need to be adjusted to position the V_1 in the center of the input voltage swing. For example, if the input clock swing is 2.5V and $V_{DD} = 3.3V$, R1 and R2 value should be adjusted to set V_1 at 1.25V. The values below are for when both the single ended swing and V_{DD} are at the same voltage. This configuration requires that the sum of the output impedance of the driver (R_o) and the series resistance (R_s) equals the transmission line impedance. In addition, matched termination at the input will attenuate the signal in half. This can be done in one of two ways. First, R3 and R4 in parallel should equal the transmission line

impedance. For most 50Ω applications, R3 and R4 can be 100Ω. The values of the resistors can be increased to reduce the loading for slower and weaker LVC MOS driver. When using single-ended signaling, the noise rejection benefits of differential signaling are reduced. Even though the differential input can handle full rail LVC MOS signaling, it is recommended that the amplitude be reduced. The datasheet specifies a lower differential amplitude, however this only applies to differential signals. For single-ended applications, the swing can be larger, however V_{IL} cannot be less than -0.3V and V_{IH} cannot be more than $V_{DD} + 0.3V$. Though some of the recommended components might not be used, the pads should be placed in the layout. They can be utilized for debugging purposes. The datasheet specifications are characterized and guaranteed by using a differential signal.

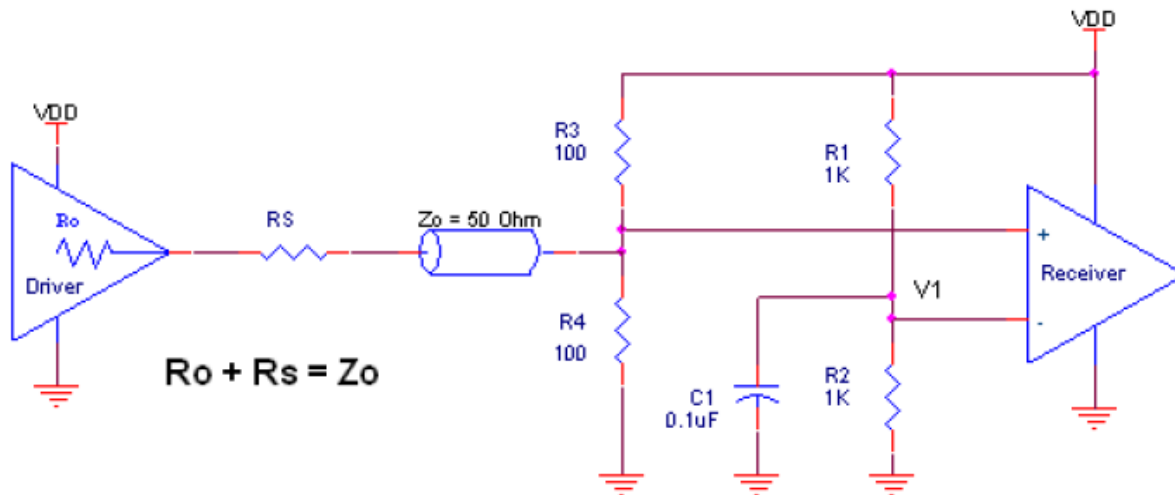

Figure 2. Recommended Schematic for Wiring a Differential Input to Accept Single-ended Levels

Differential Clock Input Interface

The CLK /nCLK accepts LVDS, LVPECL, LVHSTL, SSTL, HCSL and other differential signals. Both signals must meet the V_{PP} and V_{CMR} input requirements. *Figures 3A to 3F* show interface examples for the CLK/nCLK input driven by the most common driver types. The input interfaces suggested here are examples only. Please consult with the

vendor of the driver component to confirm the driver termination requirements. For example, in Figure 3A, the input termination applies for IDT open emitter LVHSTL drivers. If you are using an LVHSTL driver from another vendor, use their termination recommendation.

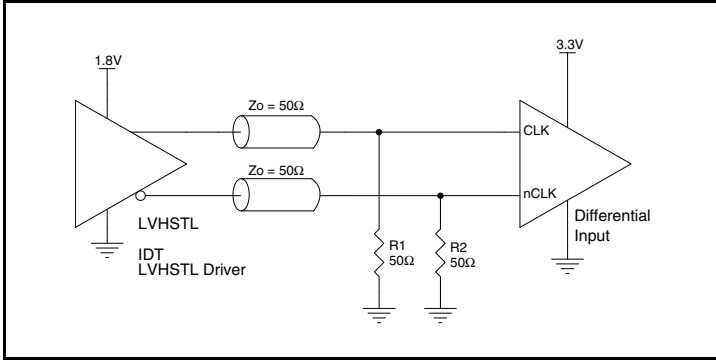

Figure 3A. CLK/nCLK Input Driven by an IDT Open Emitter LVHSTL Driver

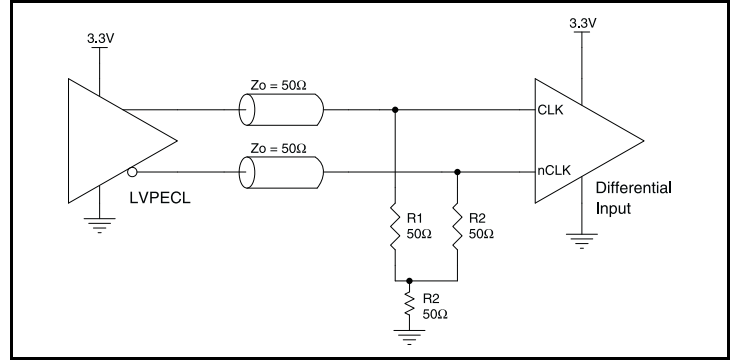

Figure 3B. CLK/nCLK Input Driven by a 3.3V LVPECL Driver

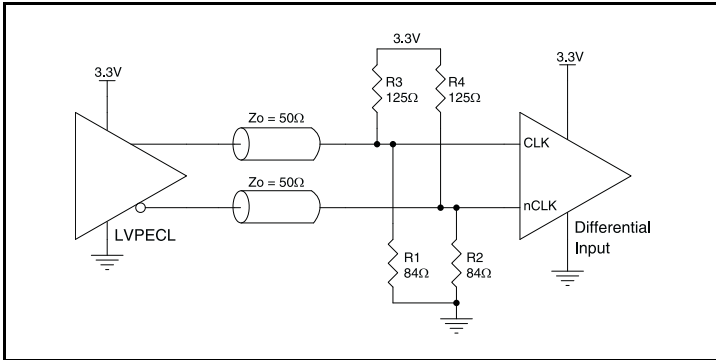

Figure 3C. CLK/nCLK Input Driven by a 3.3V LVPECL Driver

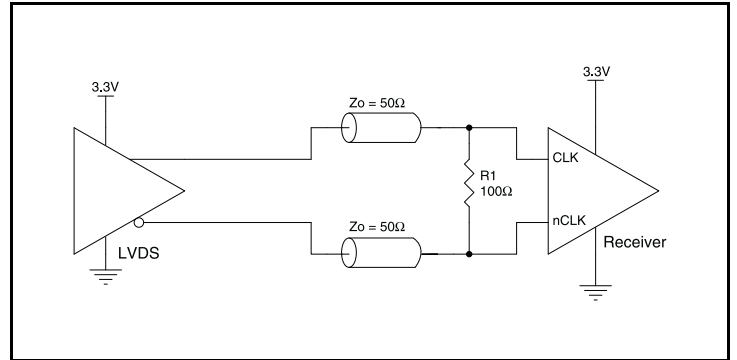

Figure 3D. CLK/nCLK Input Driven by a 3.3V LVDS Driver

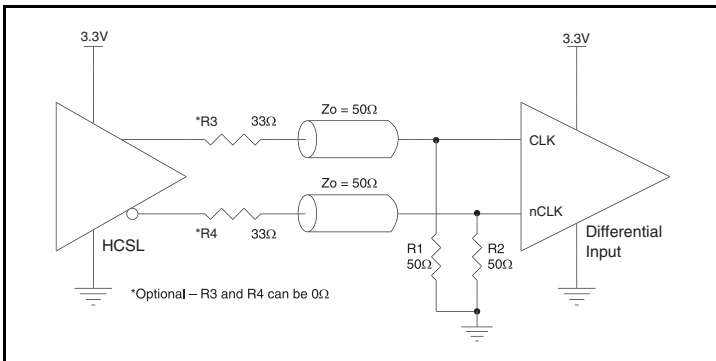

Figure 3E. CLK/nCLK Input Driven by a 3.3V HCSL Driver

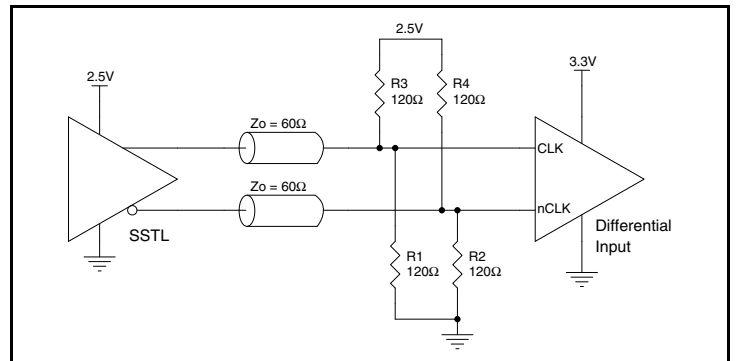

Figure 3F. CLK/nCLK Input Driven by a 2.5V SSTL Driver

Schematic Example

This application note provides general design guide using ICS8305 LVCMOS buffer. Figure 4 shows a schematic example of the ICS8305 LVCMOS clock buffer. In this example, the input is driven by

an LVCMOS driver. CLK_EN is set at logic low to select LVCMOS_CLK input.

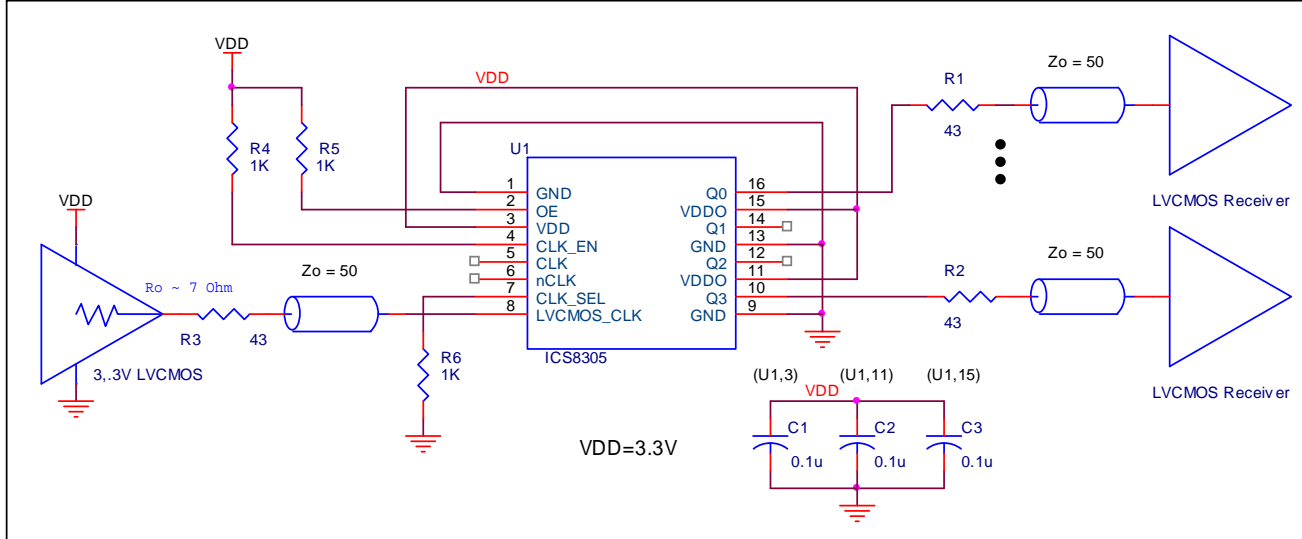

Figure 4. ICS8305 LVCMOS Clock Output Buffer Schematic Example

Reliability Information

Table 6. θ_{JA} vs. Air Flow Table for a 16 Lead TSSOP

| θ_{JA} vs. Air Flow | | | |
|--|-----------|-----------|-----------|
| Linear Feet per Minute | 0 | 200 | 500 |
| Single-Layer PCB, JEDEC Standard Test Boards | 137.1°C/W | 118.2°C/W | 106.8°C/W |
| Multi-Layer PCB, JEDEC Standard Test Boards | 89.0°C/W | 81.8°C/W | 78.1°C/W |

NOTE: Most modern PCB design use multi-layered boards. The data in the second row pertains to most designs.

Transistor Count

The transistor count for ICS8305: 459

Package Outline and Package Dimensions

Package Outline - G Suffix for 16 Lead TSSOP

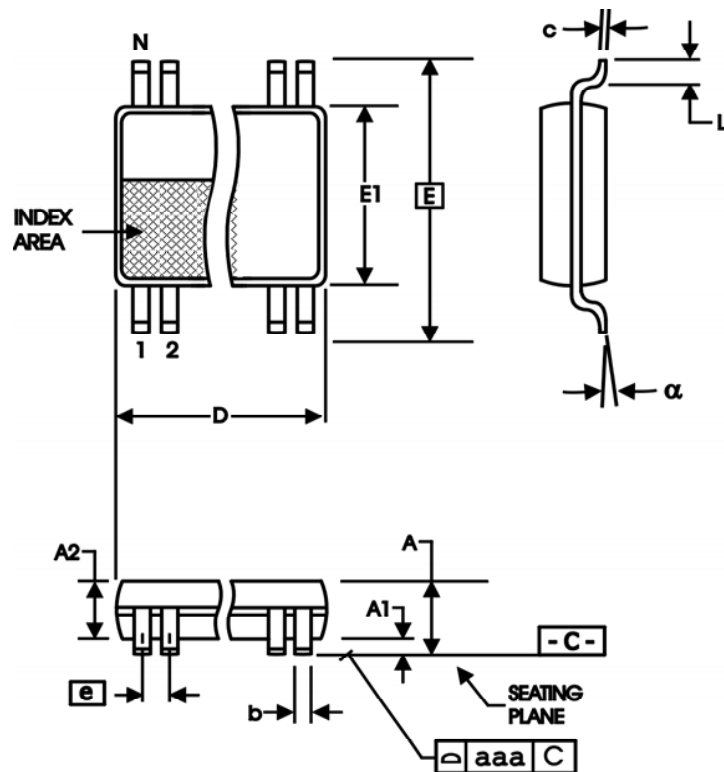

Table 7. Package Dimensions for 16 Lead TSSOP

| All Dimensions in Millimeters | | |
|-------------------------------|------------|---------|
| Symbol | Minimum | Maximum |
| N | 16 | |
| A | | 1.20 |
| A1 | 0.5 | 0.15 |
| A2 | 0.80 | 1.05 |
| b | 0.19 | 0.30 |
| c | 0.09 | 0.20 |
| D | 4.90 | 5.10 |
| E | 6.40 Basic | |
| E1 | 4.30 | 4.50 |
| e | 0.65 Basic | |
| L | 0.45 | 0.75 |
| α | 0° | 8° |
| aaa | | 0.10 |

Reference Document: JEDEC Publication 95, MO-153

Ordering Information

Table 8. Ordering Information

| Part/Order Number | Marking | Package | Shipping Packaging | Temperature |
|-------------------|----------|---------------------------|--------------------|-------------|
| 8305AGLF | 8305AGLF | "Lead-Free" 16 Lead TSSOP | Tube | 0°C to 70°C |
| 8305AGLFT | 8305AGLF | "Lead-Free" 16 Lead TSSOP | Tape & Reel | 0°C to 70°C |

Revision History Sheet

| Rev | Table | Page | Description of Change | Date |
|-----|---|------------|--|----------|
| A | T8 | 14 | Ordering Information table - corrected Part/Order Number typo from ICS88305AGT to ICS8305AGT. | 1/20/04 |
| B | T5A - T5C | 5 & 6 7 | Added Additive Phase Jitter to AC Characteristics Tables. Added Additive Phase Jitter Section. | 2/26/04 |
| B | T1 | 2 | Pin Description Table - corrected CLK_EN description. | 12/6/04 |
| C | T4A T4B T5D T8 | 1 | Features Section - added 1.5V output to Supply Mode bullet and added Lead-Free bullet. | 11/17/05 |
| | | 4 | Power Supply DC Characteristics Table - added V_{DDO} 1.5V. | |
| | | 4 | LVC MOS DC Characteristics Table - added V_{OH}/V_{OL} 1.5V. | |
| | | 7 | Added 3.3V/1.5V AC Characteristics Table. | |
| | | 10 | Added 3.3V/1.5V Output Load AC Test Circuit Drawing. | |
| 11 | Added Recommendations for Unused Input and Output Pins. | 16 | Added Lead-Free part number. | |
| C | T8 | 15 | Ordering Information Table - added lead-free marking. Corrected non-lead free marking from ICS8305AG to 8305AG. | 2/22/08 |
| C | T5A-T5D 8 | 1, 12 | Updated to current datasheet format | 9/17/12 |
| | | 6, 7 | Deleted HiPerClockS references. | |
| | | 11 | Added Note: Electrical parameters are guaranteed ... to Notes | |
| 15 | Updated the 'Wiring the Differential Input to Accept Single Ended Levels' section Deleted: ICS from part numbers; quantity from shipping; LF Note; disclaimer. | | | |
| C | T8 | 1 | Features Section - removed leaded part reference | 5/30/14 |
| | | 15 | Ordering Information - removed leaded parts. PDN# CQ-13-02 | |
| | | 17 | Updated Technical Support contact email address | |

IMPORTANT NOTICE AND DISCLAIMER

RENESAS ELECTRONICS CORPORATION AND ITS SUBSIDIARIES (“RENESAS”) PROVIDES TECHNICAL SPECIFICATIONS AND RELIABILITY DATA (INCLUDING DATASHEETS), DESIGN RESOURCES (INCLUDING REFERENCE DESIGNS), APPLICATION OR OTHER DESIGN ADVICE, WEB TOOLS, SAFETY INFORMATION, AND OTHER RESOURCES “AS IS” AND WITH ALL FAULTS, AND DISCLAIMS ALL WARRANTIES, EXPRESS OR IMPLIED, INCLUDING, WITHOUT LIMITATION, ANY IMPLIED WARRANTIES OF MERCHANTABILITY, FITNESS FOR A PARTICULAR PURPOSE, OR NON-INFRINGEMENT OF THIRD PARTY INTELLECTUAL PROPERTY RIGHTS.

These resources are intended for developers skilled in the art designing with Renesas products. You are solely responsible for (1) selecting the appropriate products for your application, (2) designing, validating, and testing your application, and (3) ensuring your application meets applicable standards, and any other safety, security, or other requirements. These resources are subject to change without notice. Renesas grants you permission to use these resources only for development of an application that uses Renesas products. Other reproduction or use of these resources is strictly prohibited. No license is granted to any other Renesas intellectual property or to any third party intellectual property. Renesas disclaims responsibility for, and you will fully indemnify Renesas and its representatives against, any claims, damages, costs, losses, or liabilities arising out of your use of these resources. Renesas' products are provided only subject to Renesas' Terms and Conditions of Sale or other applicable terms agreed to in writing. No use of any Renesas resources expands or otherwise alters any applicable warranties or warranty disclaimers for these products.

(Rev.1.0 Mar 2020)

Corporate Headquarters

TOYOSU FORESIA, 3-2-24 Toyosu,
Koto-ku, Tokyo 135-0061, Japan
www.renesas.com

Contact Information

For further information on a product, technology, the most up-to-date version of a document, or your nearest sales office, please visit:
www.renesas.com/contact/

Trademarks

Renesas and the Renesas logo are trademarks of Renesas Electronics Corporation. All trademarks and registered trademarks are the property of their respective owners.