

GENERAL DESCRIPTION

The 83026I-01 is a low skew, 1-to-2 Differential-to-LVCMOS/LVTTL Fanout Buffer. The differential input can accept most differential signal types (LVPECL, LVDS, LVHSTL, HCSL and SSTL) and translate to two single-ended LVCMOS/LVTTL outputs. The small 8-lead SOIC footprint makes this device ideal for use in applications with limited board space.

FEATURES

- Two LVCMOS / LVTTL outputs
- Differential CLK, nCLK input pair
- CLK, nCLK pair can accept the following differential input levels: LVPECL, LVDS, LVHSTL, HCSL, SSTL
- Maximum output frequency: 350MHz
- Output skew: 15ps (maximum)
- Part-to-part skew: 600ps (maximum)
- Additive phase jitter, RMS: 0.03ps (typical)
- Small 8 lead SOIC package saves board space
- 3.3V core, 3.3V, 2.5V or 1.8V output operating supply
- -40°C to 85°C ambient operating temperature
- Available in lead-free RoHS (6) package

BLOCK DIAGRAM

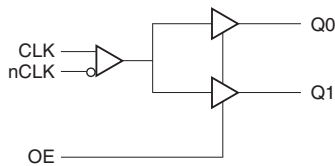

PIN ASSIGNMENT

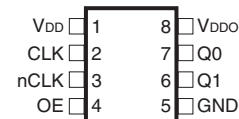

83026I-01 8-Lead SOIC

3.8mm x 4.8mm, x 1.47mm package body
M Package
Top View

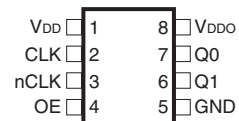

83026I-01 8-Lead TSSOP

4.40mm x 3.0mm x 0.925mm
package body
G Package
Top View

TABLE 1. PIN DESCRIPTIONS

Number	Name	Type		Description
1	V _{DD}	Power		Positive supply pin.
2	CLK	Input	Pulldown	Non-inverting differential clock input.
3	nCLK	Input	Pullup/ Pulldown	Inverting differential clock input. V _{DD} /2 default when left floating.
4	OE	Input	Pullup	Output enable. When HIGH, outputs are enabled. When LOW, outputs are in High Impedance State. LVCMOS / LVTTTL interface levels.
5	GND	Power		Power supply ground.
6	Q1	Output		Clock output. LVCMOS / LVTTTL interface levels.
7	Q0	Output		Clock output. LVCMOS / LVTTTL interface levels.
8	V _{DDO}	Power		Output supply pin.

NOTE: *Pullup* and *Pulldown* refer to internal input resistors. See Table 2, Pin Characteristics, for typical values.

TABLE 2. PIN CHARACTERISTICS

Symbol	Parameter	Test Conditions	Minimum	Typical	Maximum	Units
C _{IN}	Input Capacitance			4		pF
C _{PD}	Power Dissipation Capacitance (per output)	V _{DD} , V _{DDO} = 3.465V			17	pF
		V _{DD} = 3.465V, V _{DDO} = 2.625V			16	pF
		V _{DD} = 3.465V, V _{DDO} = 1.95V			15	pF
R _{PULLUP}	Input Pullup Resistor			51		kΩ
R _{PULLDOWN}	Input Pulldown Resistor			51		kΩ
R _{OUT}	Output Impedance	V _{DD} , V _{DDO} = 3.3V		7		Ω
		V _{DD} = 3.3V, V _{DDO} = 2.5V		8		Ω
		V _{DD} = 3.3V, V _{DDO} = 1.8V		10		Ω

TABLE 3. CONTROL FUNCTION TABLE

Input	Outputs
OE	Q0, Q1
0	HiZ
1	Active

ABSOLUTE MAXIMUM RATINGS

Supply Voltage, V_{DD}	4.6V
Inputs, V_I	-0.5V to $V_{DD} + 0.5V$
Outputs, V_O	-0.5V to $V_{DDO} + 0.5V$
Package Thermal Impedance, θ_{JA}	
8 Lead SOIC	112.7°C/W (0 lfpm)
8 Lead TSSOP	101.7°C/W (0 lfpm)
Storage Temperature, T_{STG}	-65°C to 150°C

NOTE: Stresses beyond those listed under Absolute Maximum Ratings may cause permanent damage to the device. These ratings are stress specifications only. Functional operation of product at these conditions or any conditions beyond those listed in the *DC Characteristics* or *AC Characteristics* is not implied. Exposure to absolute maximum rating conditions for extended periods may affect product reliability.

TABLE 3A. POWER SUPPLY DC CHARACTERISTICS, $V_{DD} = 3.3V \pm 5\%$, $V_{DDO} = 1.71V$ TO $3.465V$, $T_A = -40^\circ C$ TO $85^\circ C$

Symbol	Parameter	Test Conditions	Minimum	Typical	Maximum	Units
V_{DD}	Positive Supply Voltage		3.135	3.3	3.465	V
V_{DDO}	Output Supply Voltage		3.135	3.3	3.465	V
			2.375	2.5	2.625	V
			1.71	1.8	1.89	V
I_{DD}	Power Supply Current			10	mA	
I_{DDO}	Output Supply Current			3	mA	

TABLE 3B. LVCMOS / LVTTTL DC CHARACTERISTICS, $V_{DD} = 3.3V \pm 5\%$, $V_{DDO} = 2.375V$ TO $3.465V$, $T_A = -40^\circ C$ TO $85^\circ C$

Symbol	Parameter	Test Conditions	Minimum	Typical	Maximum	Units
V_{IH}	Input High Voltage	OE	2		$V_{DD} + 0.3$	V
V_{IL}	Input Low Voltage	OE	-0.3		0.8	V
I_{IH}	Input High Current	OE	$V_{DD} = V_{IN} = 3.465V$		5	μA
I_{IL}	Input Low Current	OE	$V_{DD} = 3.465V, V_{IN} = 0V$			μA
V_{OH}	Output High Voltage; NOTE 1		$V_{DDO} = 3.135V$		2.6	V
			$V_{DDO} = 2.375V$		1.8	V
V_{OL}	Output Low Voltage; NOTE 1				0.5	V

NOTE 1: Outputs terminated with 50Ω to $V_{DDO}/2$. See Parameter Measurement Information section, "Output Load Test Circuit" diagrams.

TABLE 3C. LVCMOS / LVTTTL DC CHARACTERISTICS, $V_{DD} = 3.3V \pm 5\%$, $V_{DDO} = 1.8V \pm 5\%$, $T_A = -40^\circ C$ TO $85^\circ C$

Symbol	Parameter	Test Conditions	Minimum	Typical	Maximum	Units
V_{IH}	Input High Voltage	OE	2		$V_{DD} + 0.3$	V
V_{IL}	Input Low Voltage	OE	-0.3		0.8	V
I_{IH}	Input High Current	OE	$V_{DD} = V_{IN} = 3.465V$		5	μA
I_{IL}	Input Low Current	OE	$V_{DD} = 3.465V, V_{IN} = 0V$		-150	μA
V_{OH}	Output High Voltage		$I_{OH} = -100\mu A$		$V_{DDO} - 0.2$	V
			$I_{OH} = -2mA$		$V_{DDO} - 0.45$	V
V_{OL}	Output Low Voltage		$I_{OL} = 100\mu A$		0.2	V
			$I_{OL} = 2mA$		0.45	V

TABLE 3D. DIFFERENTIAL DC CHARACTERISTICS, $V_{DD} = 3.3V \pm 5\%$, $V_{DDO} = 1.71V$ TO $3.465V$, $T_A = -40^\circ C$ TO $85^\circ C$

Symbol	Parameter	Test Conditions	Minimum	Typical	Maximum	Units
I_{IH}	Input High Current	nCLK	$V_{IN} = V_{DD} = 3.465V$		150	μA
		CLK	$V_{IN} = V_{DD} = 3.465V$		150	μA
I_{IL}	Input Low Current	nCLK	$V_{IN} = 0V, V_{DD} = 3.465V$	-150		μA
		CLK	$V_{IN} = 0V, V_{DD} = 3.465V$	-5		μA
V_{PP}	Peak-to-Peak Input Voltage; NOTE 1		0.15		1.3	V
V_{CMR}	Common Mode Input Voltage; NOTE 2, 3		GND + 0.5		$V_{DD} - 0.85$	V

NOTE 1: V_{PP} can exceed 1.3V provided that there is sufficient offset level to keep $V_{IL} > 0V$.

NOTE 2: For single ended applications, the maximum input voltage for CLK, nCLK is $V_{DD} + 0.3V$.

NOTE 3: Common mode voltage is defined as V_{IH} .

TABLE 4A. AC CHARACTERISTICS, $V_{DD} = 3.3V \pm 5\%$, $V_{DDO} = 3.3V \pm 5\%$, $T_A = -40^\circ C$ TO $85^\circ C$

Symbol	Parameter	Test Conditions	Minimum	Typical	Maximum	Units
f_{MAX}	Output Frequency				350	MHz
t_{PD}	Propagation Delay; NOTE 1	$f \leq 350MHz$	1.3	1.9	2.5	ns
$t_{sk(o)}$	Output Skew; NOTE 2, 4				15	ps
$t_{sk(pp)}$	Part-to-Part Skew; NOTE 3, 4				900	ps
t_{jit}	Buffer Additive Phase Jitter, RMS, refer to Additive Phase Jitter Section			0.03		ps
t_R / t_F	Output Rise/Fall Time	20% to 80%	150		800	ps
odc	Output Duty Cycle	$f \leq 66MHz$	48		52	%
		$67MHz \leq f \leq 166MHz$	45		55	%
		$167MHz \leq f \leq 350MHz$	40		60	%

NOTE 1: Measured from the differential input crossing point to $V_{DDO}/2$ of the output.

NOTE 2: Defined as skew between outputs at the same supply voltage and with equal load conditions.

Measured at $V_{DDO}/2$.

NOTE 3: Defined as skew between outputs on different devices operating at the same supply voltages and with equal load conditions. Using the same type of inputs on each device, the outputs are measured at $V_{DDO}/2$.

NOTE 4: This parameter is defined in accordance with JEDEC Standard 6.

TABLE 4B. AC CHARACTERISTICS, $V_{DD} = 3.3V \pm 5\%$, $V_{DDO} = 2.5V \pm 5\%$, $T_A = -40^{\circ}C$ TO $85^{\circ}C$

Symbol	Parameter	Test Conditions	Minimum	Typical	Maximum	Units
f_{MAX}	Output Frequency				350	MHz
t_{PD}	Propagation Delay; NOTE 1	$f \leq 350MHz$	1.5	2.0	2.6	ns
$tsk(o)$	Output Skew; NOTE 2, 4				15	ps
$tsk(pp)$	Part-to-Part Skew; NOTE 3, 4				750	ps
t_{jit}	Buffer Additive Phase Jitter, RMS, refer to Additive Phase Jitter Section			0.03		ps
t_R / t_F	Output Rise/Fall Time	20% to 80%	150		800	ps
odc	Output Duty Cycle	$f \leq 66MHz$	48		52	%
		$67MHz \leq f \leq 166MHz$	46		54	%
		$167MHz \leq f \leq 350MHz$	40		60	%

NOTE 1: Measured from the differential input crossing point to $V_{DDO}/2$ of the output.

NOTE 2: Defined as skew between outputs at the same supply voltage and with equal load conditions.

Measured at $V_{DDO}/2$.

NOTE 3: Defined as skew between outputs on different devices operating at the same supply voltages and with equal load conditions. Using the same type of inputs on each device, the outputs are measured at $V_{DDO}/2$.

NOTE 4: This parameter is defined in accordance with JEDEC Standard 65.

TABLE 4C. AC CHARACTERISTICS, $V_{DD} = 3.3V \pm 5\%$, $V_{DDO} = 1.8V \pm 5\%$, $T_A = -40^{\circ}C$ TO $85^{\circ}C$

Symbol	Parameter	Test Conditions	Minimum	Typical	Maximum	Units
f_{MAX}	Output Frequency				350	MHz
t_{PD}	Propagation Delay; NOTE 1	$f \leq 350MHz$	1.9	2.5	3.1	ns
$tsk(o)$	Output Skew; NOTE 2, 4				15	ps
$tsk(pp)$	Part-to-Part Skew; NOTE 3, 4				600	ps
t_{jit}	Buffer Additive Phase Jitter, RMS, refer to Additive Phase Jitter Section			0.03		ps
t_R / t_F	Output Rise/Fall Time	20% to 80%	200		900	ps
odc	Output Duty Cycle	$f \leq 66MHz$	48		52	%
		$67MHz \leq f \leq 166MHz$	43		57	%
		$167MHz \leq f \leq 350MHz$	40		60	%

NOTE 1: Measured from the differential input crossing point to $V_{DDO}/2$ of the output.

NOTE 2: Defined as skew between outputs at the same supply voltage and with equal load conditions.

Measured at $V_{DDO}/2$.

NOTE 3: Defined as skew between outputs on different devices operating at the same supply voltages and with equal load conditions. Using the same type of inputs on each device, the outputs are measured at $V_{DDO}/2$.

NOTE 4: This parameter is defined in accordance with JEDEC Standard 65.

ADDITIVE PHASE JITTER

The spectral purity in a band at a specific offset from the fundamental compared to the power of the fundamental is called the **dBc Phase Noise**. This value is normally expressed using a Phase noise plot and is most often the specified plot in many applications. Phase noise is defined as the ratio of the noise power present in a 1Hz band at a specified offset from the fundamental frequency to the power value of the fundamental. This ratio is expressed in decibels (dBm) or a ratio of the power in the

1Hz band to the power in the fundamental. When the required offset is specified, the phase noise is called a **dBc** value, which simply means dBm at a specified offset from the fundamental. By investigating jitter in the frequency domain, we get a better understanding of its effects on the desired application over the entire time record of the signal. It is mathematically possible to calculate an expected bit error rate given a phase noise plot.

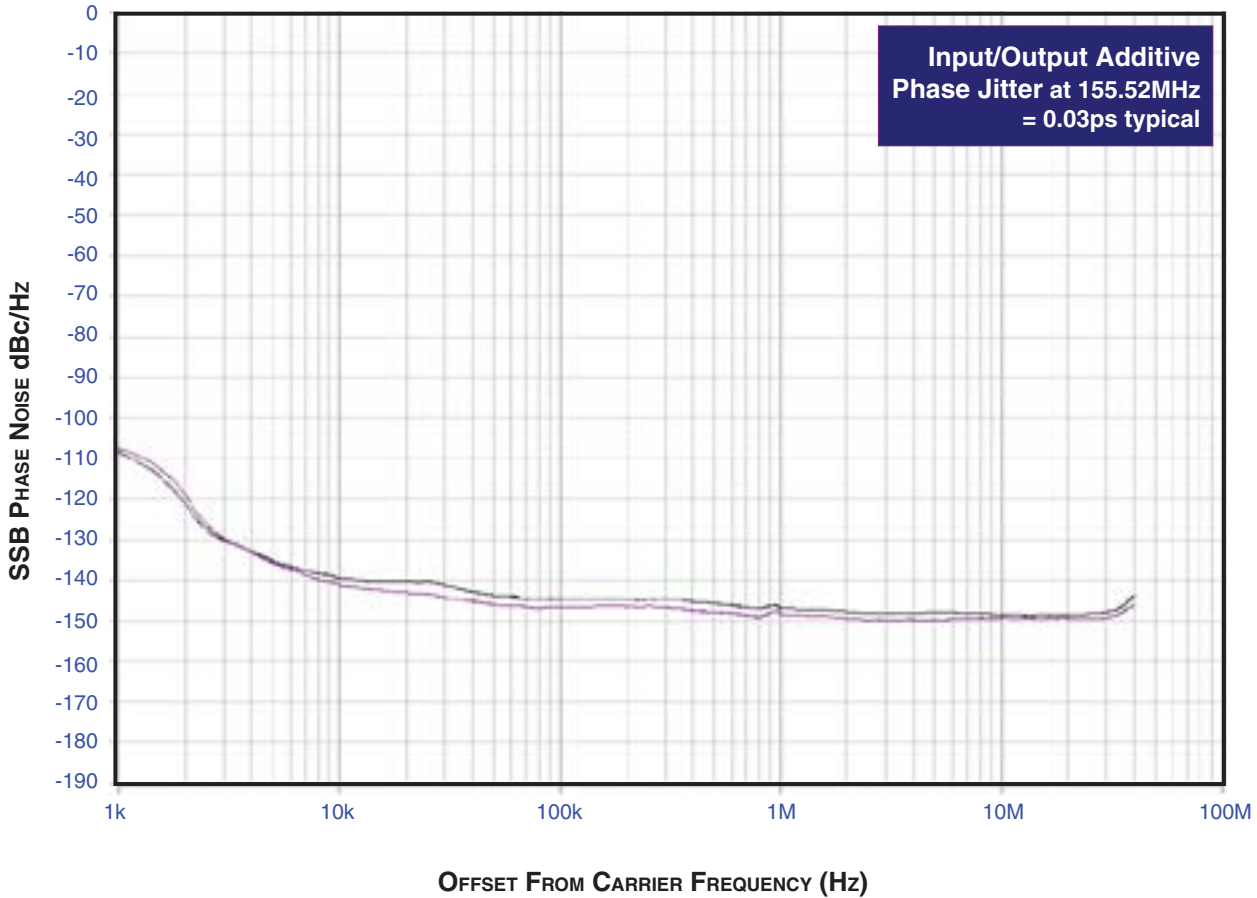

As with most timing specifications, phase noise measurements have issues. The primary issue relates to the limitations of the equipment. Often the noise floor of the equipment is higher than the noise floor of the device. This is illustrated above. The

device meets the noise floor of what is shown, but can actually be lower. The phase noise is dependant on the input source and measurement equipment.

PARAMETER MEASUREMENT INFORMATION

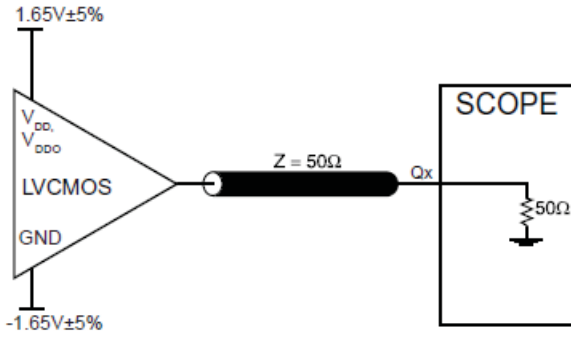

3.3V_{CORE}/3.3V OUTPUT LOAD AC TEST CIRCUIT

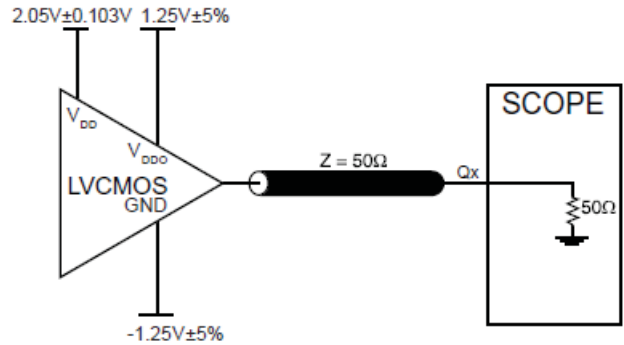

3.3V_{CORE}/2.5V OUTPUT LOAD AC TEST CIRCUIT

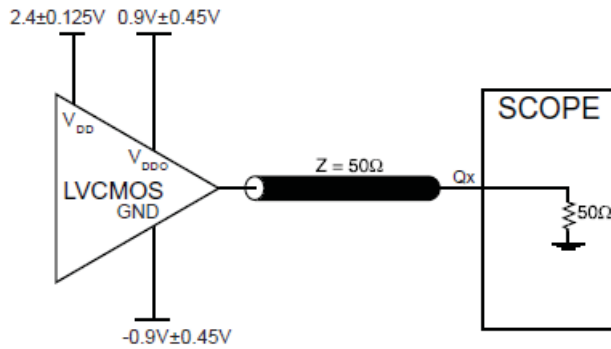

3.3V_{CORE}/1.8V OUTPUT LOAD AC TEST CIRCUIT

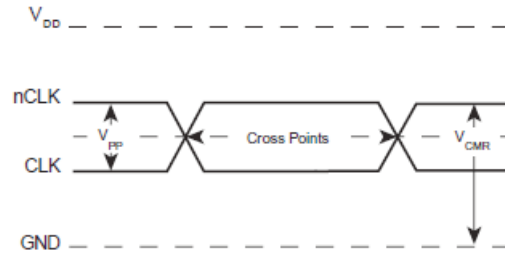

DIFFERENTIAL INPUT LEVEL



OUTPUT SKEW

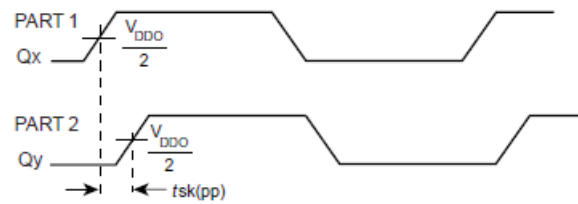

PART-TO-PART SKEW

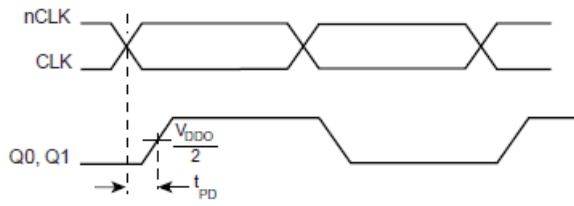

PROPAGATION DELAY

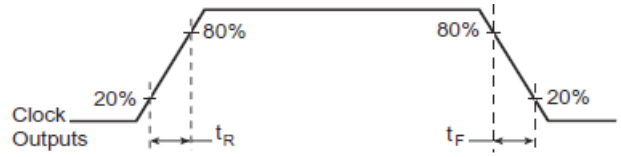

OUTPUT RISE/FALL TIME

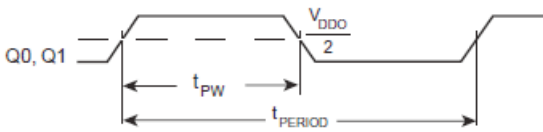

$$odc = \frac{t_{PW}}{t_{PERIOD}} \times 100\%$$

OUTPUT DUTY CYCLE/PULSE WIDTH/PERIOD

APPLICATION INFORMATION

WIRING THE DIFFERENTIAL INPUT TO ACCEPT SINGLE ENDED LEVELS

Figure 1 shows how the differential input can be wired to accept single ended levels. The reference voltage $V_{REF} = V_{DD}/2$ is generated by the bias resistors R1, R2 and C1. This bias circuit should be located as close as possible to the input pin.

The ratio of R1 and R2 might need to be adjusted to position the V_{REF} in the center of the input voltage swing. For example, if the input clock swing is only 2.5V and $V_{DD} = 3.3V$, V_{REF} should be 1.25V and $R2/R1 = 0.609$.

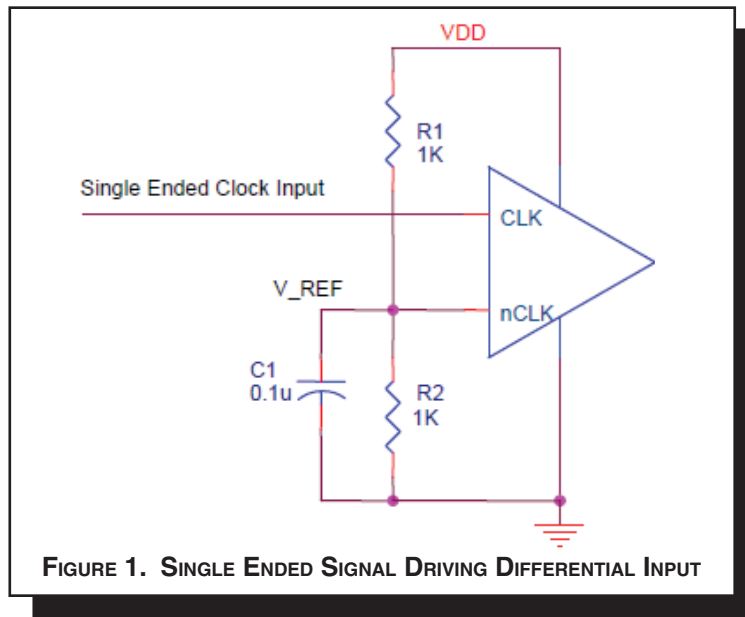

RECOMMENDATIONS FOR UNUSED OUTPUT PINS

OUTPUTS:

LVC MOS OUTPUTS

All unused LVC MOS output can be left floating. We recommend that there is no trace attached.

DIFFERENTIAL CLOCK INPUT INTERFACE

The CLK/nCLK accepts LVDS, LVPECL, LVHSTL, SSTL, HCSTL and other differential signals. Both V_{SWING} and V_{OH} must meet the V_{PP} and V_{CMR} input requirements. Figures 2A to 2E show interface examples for the CLK/nCLK input driven by the most common driver types. The input interfaces suggested here are

examples only. Please consult with the vendor of the driver component to confirm the driver termination requirements. For example in *Figure 2A*, the input termination applies for LVHSTL drivers. If you are using an LVHSTL driver from another vendor, use their termination recommendation.

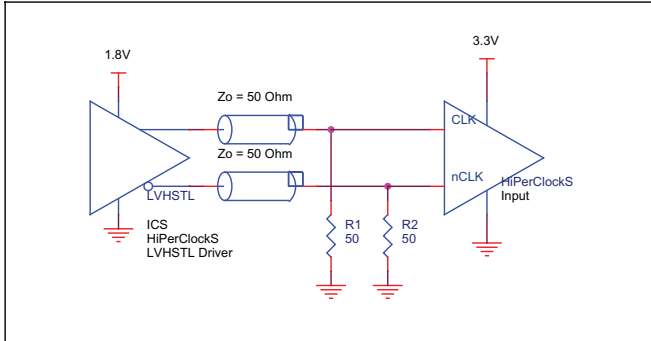

FIGURE 2A. CLK/nCLK INPUT DRIVEN BY LVHSTL DRIVER

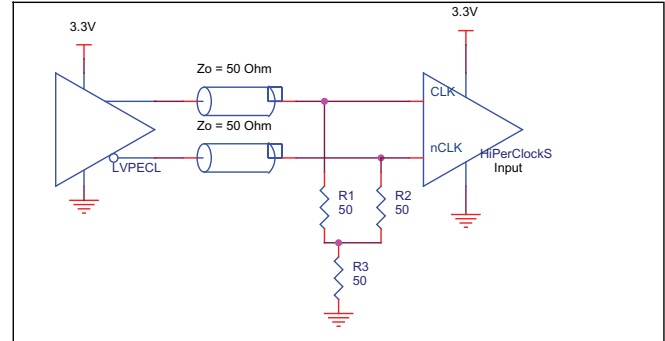

FIGURE 2B. CLK/nCLK INPUT DRIVEN BY 3.3V LVPECL DRIVER

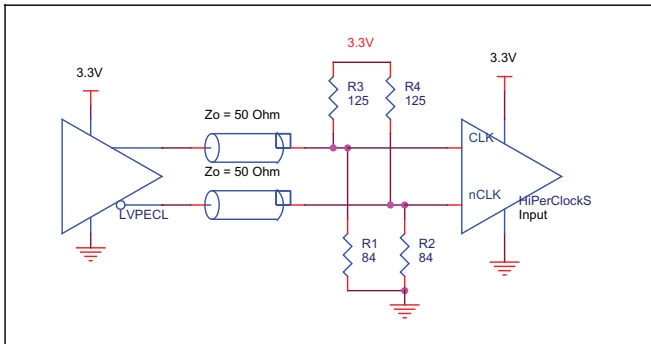

FIGURE 2C. CLK/nCLK INPUT DRIVEN BY 3.3V LVPECL DRIVER

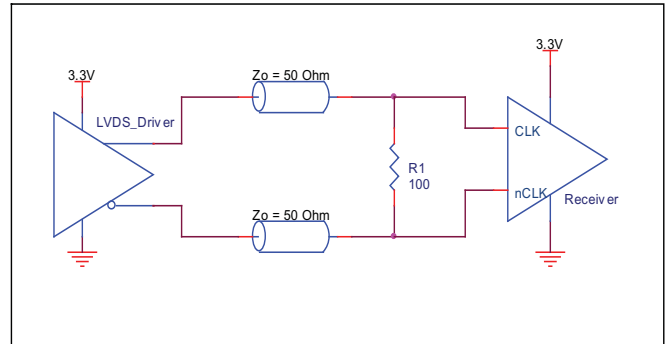

FIGURE 2D. CLK/nCLK INPUT DRIVEN BY 3.3V LVDS DRIVER

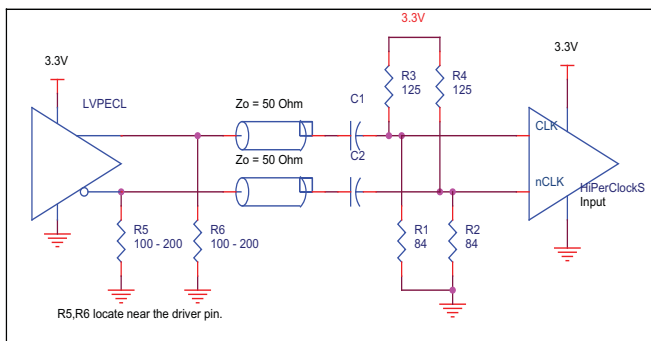

FIGURE 2E. CLK/nCLK INPUT DRIVEN BY 3.3V LVPECL DRIVER WITH AC COUPLE

SCHEMATIC EXAMPLE

Figure 3 shows an application schematic example of 83026I-01. The 83026I-01 CLK/nCLK input can directly accept various types of differential signal. In this example, the input is driven by an LVDS driver. The 83026I-01 outputs are LVC MOS drivers. In

this example, series termination approach is shown. Additional termination approaches are shown in the LVC MOS Termination Application Note.

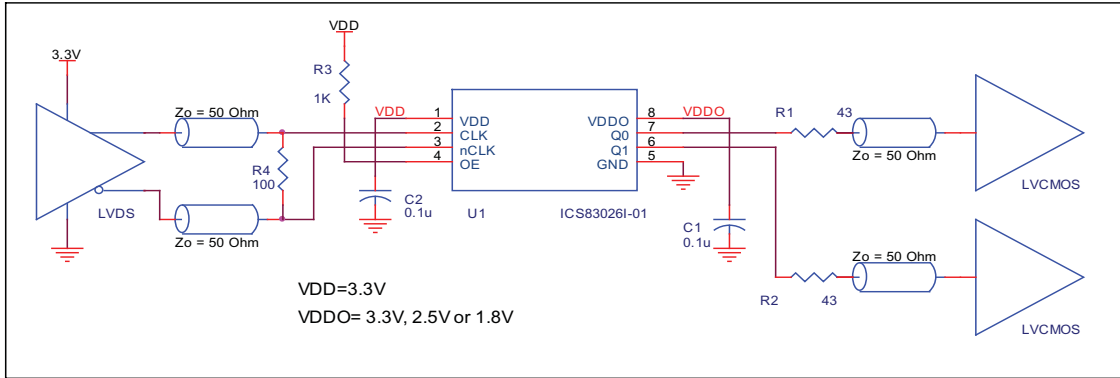

FIGURE 3. 83026I-01 SCHEMATIC EXAMPLE

RELIABILITY INFORMATION

TABLE 5A. θ_{JA} VS. AIR FLOW TABLE FOR 8 LEAD SOIC

θ_{JA} by Velocity (Linear Feet per Minute)			
	0	200	500
Single-Layer PCB, JEDEC Standard Test Boards	153.3°C/W	128.5°C/W	115.5°C/W
Multi-Layer PCB, JEDEC Standard Test Boards	112.7°C/W	103.3°C/W	97.1°C/W

NOTE: Most modern PCB designs use multi-layered boards. The data in the second row pertains to most designs.

TABLE 5B. θ_{JA} VS. AIR FLOW TABLE FOR 8 LEAD TSSOP

θ_{JA} by Velocity (Linear Feet per Minute)			
	0	200	500
Multi-Layer PCB, JEDEC Standard Test Boards	101.7°C/W	90.5°C/W	89.8°C/W

TRANSISTOR COUNT

The transistor count for ICS83026I-01 is: 260

PACKAGE OUTLINE - SUFFIX M FOR 8 LEAD SOIC

PACKAGE OUTLINE - G SUFFIX FOR 8 LEAD TSSOP

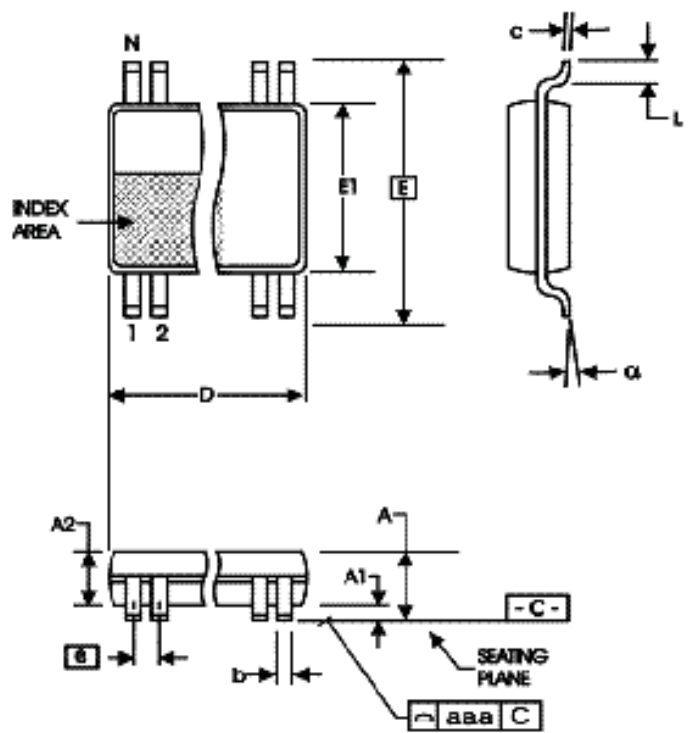
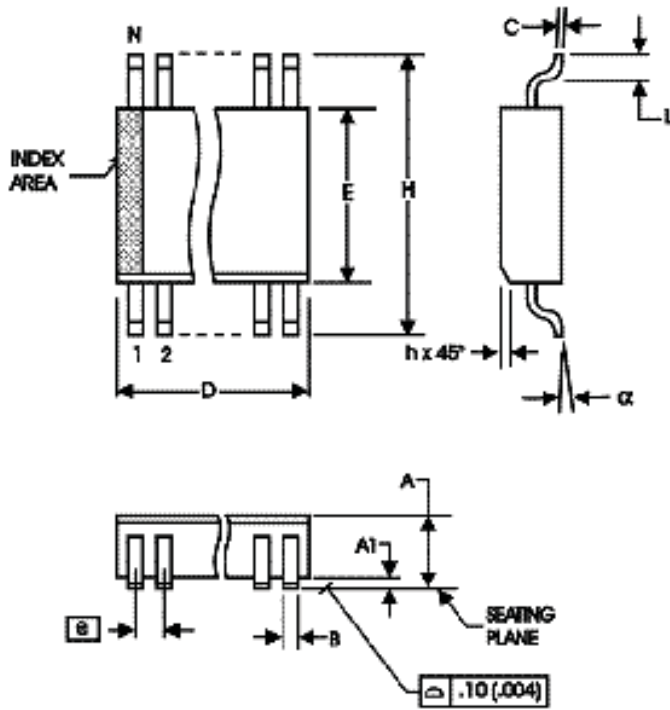

TABLE 6A. PACKAGE DIMENSIONS

SYMBOL	Millimeters	
	MINIMUM	MAXIMUM
N	8	
A	1.35	1.75
A1	0.10	0.25
B	0.33	0.51
C	0.19	0.25
D	4.80	5.00
E	3.80	4.00
e	1.27 BASIC	
H	5.80	6.20
h	0.25	0.50
L	0.40	1.27
α	0°	8°

Reference Document: JEDEC Publication 95, MS-012

TABLE 6B. PACKAGE DIMENSIONS

SYMBOL	Millimeters	
	Minimum	Maximum
N	8	
A	--	1.20
A1	0.05	0.15
A2	0.80	1.05
b	0.19	0.30
c	0.09	0.20
D	2.90	3.10
E	6.40 BASIC	
E1	4.30	4.50
e	0.65 BASIC	
L	0.45	0.75
α	0°	8°
aaa	--	0.10

Reference Document: JEDEC Publication 95, MO-153

TABLE 7. ORDERING INFORMATION

Part/Order Number	Marking	Package	Shipping Packaging	Temperature
83026BMI-01LF	026BI01L	8 lead "Lead Free" SOIC	Tube	-40°C to +85°C
83026BMI-01LFT	026BI01L	8 lead "Lead Free" SOIC	Tape and Reel	-40°C to +85°C
83026BGI-01LF	BI01L	8 lead "Lead Free" TSSOP	Tube	-40°C to +85°C
83026BGI-01LFT	BI01L	8 lead "Lead Free" TSSOP	Tape and Reel	-40°C to +85°C

REVISION HISTORY SHEET				
Rev	Table	Page	Description of Change	Date
A	T7	1	Added 8 Lead TSSOP package to Pin Assignment.	6/25/04
		3	Absolute Maximum Ratings - added 8 Lead TSSOP to Package Thermal Impedance.	
		11	Added 8 Lead TSSOP Reliability Information table.	
		12	Added 8 Lead TSSOP Package Outline and Package Dimensions.	
		13	Ordering Information Table - added 8 Lead TSSOP ordering information.	
A		6	Additive Phase Jitter - corrected X axis on plot.	8/2/05
A	T3C	3	LVC MOS DC Characteristics - corrected Test Conditions for IIH and IIL.	8/12/05
A	T7	1	Features Section - added lead-free bullet	1/16/06
		9	Added Recommendations for Unused Output Pins.	
		13	Ordering Information Table - added lead-free part number, marking, and note.	
A	T7	13	Ordering Information Table - added lead-free marking	10/22/07
A	T7	13	Updated datasheet's header/footer with IDT from ICS.	8/4/10
		15	Removed ICS prefix from Part/Order Number column. Added Contact Page.	
A	T7	1	Removed the ICS prefix on part numbers.	12/15/15
		13	Features Section - removed reference to leaded packages. Ordering Information - removed 2500 from Tape and Reel. Removed LF note below the table. Updated datasheet header and footer	

IMPORTANT NOTICE AND DISCLAIMER

RENESAS ELECTRONICS CORPORATION AND ITS SUBSIDIARIES (“RENESAS”) PROVIDES TECHNICAL SPECIFICATIONS AND RELIABILITY DATA (INCLUDING DATASHEETS), DESIGN RESOURCES (INCLUDING REFERENCE DESIGNS), APPLICATION OR OTHER DESIGN ADVICE, WEB TOOLS, SAFETY INFORMATION, AND OTHER RESOURCES “AS IS” AND WITH ALL FAULTS, AND DISCLAIMS ALL WARRANTIES, EXPRESS OR IMPLIED, INCLUDING, WITHOUT LIMITATION, ANY IMPLIED WARRANTIES OF MERCHANTABILITY, FITNESS FOR A PARTICULAR PURPOSE, OR NON-INFRINGEMENT OF THIRD-PARTY INTELLECTUAL PROPERTY RIGHTS.

These resources are intended for developers who are designing with Renesas products. You are solely responsible for (1) selecting the appropriate products for your application, (2) designing, validating, and testing your application, and (3) ensuring your application meets applicable standards, and any other safety, security, or other requirements. These resources are subject to change without notice. Renesas grants you permission to use these resources only to develop an application that uses Renesas products. Other reproduction or use of these resources is strictly prohibited. No license is granted to any other Renesas intellectual property or to any third-party intellectual property. Renesas disclaims responsibility for, and you will fully indemnify Renesas and its representatives against, any claims, damages, costs, losses, or liabilities arising from your use of these resources. Renesas' products are provided only subject to Renesas' Terms and Conditions of Sale or other applicable terms agreed to in writing. No use of any Renesas resources expands or otherwise alters any applicable warranties or warranty disclaimers for these products.

(Disclaimer Rev.1.01 Jan 2024)

Corporate Headquarters

TOYOSU FORESIA, 3-2-24 Toyosu,
Koto-ku, Tokyo 135-0061, Japan
www.renesas.com

Trademarks

Renesas and the Renesas logo are trademarks of Renesas Electronics Corporation. All trademarks and registered trademarks are the property of their respective owners.

Contact Information

For further information on a product, technology, the most up-to-date version of a document, or your nearest sales office, please visit www.renesas.com/contact-us/.