



IDT82V3389
Datasheet

SYNCHRONOUS ETHERNET
IDT WAN PLL™

IDT CONFIDENTIAL

Version 6
DATASHEET
June 13, 2012

DISCLAIMER

Integrated Device Technology, Inc. reserves the right to make changes to its products or specifications at any time, without notice, in order to improve design or performance and to supply the best possible product. IDT does not assume any responsibility for use of any circuitry described other than the circuitry embodied in an IDT product. The Company makes no representations that circuitry described herein is free from patent infringement or other rights of third parties which may result from its use. No licenses are granted by implication or otherwise under any patent, patent rights or other rights, of Integrated Device Technology, Inc.

LIFE SUPPORT POLICY

Integrated Device Technology's products are not authorized for use as critical components in life support devices or systems unless a specific written agreement pertaining to such intended use is executed between the manufacturer and an officer of IDT.

1. Life support devices or systems are devices or systems which (a) are intended for surgical implant into the body or (b) support or sustain life and whose failure to perform, when properly used in accordance with instructions for use provided in the labeling, can be reasonably expected to result in a significant injury to the user.
2. A critical component is any components of a life support device or system whose failure to perform can be reasonably expected to cause the failure of the life support device or system, or to affect its safety or effectiveness.



Table of Contents

DATASHEET

.....	9
FEATURES	9
HIGHLIGHTS.....	9
MAIN FEATURES	9
OTHER FEATURES.....	9
APPLICATIONS	9
DESCRIPTION	10
FUNCTIONAL BLOCK DIAGRAM	11
1 PIN ASSIGNMENT	12
2 PIN DESCRIPTION	13
3 FUNCTIONAL DESCRIPTION	18
3.1 RESET	18
3.2 MASTER CLOCK	18
3.3 INPUT CLOCKS & FRAME SYNC SIGNAL	19
3.3.1 Input Clocks	19
3.3.2 Frame SYNC Input Signals	19
3.4 INPUT CLOCK PRE-DIVIDER	20
3.5 INPUT CLOCK QUALITY MONITORING	22
3.5.1 Activity Monitoring	22
3.5.2 Frequency Monitoring	23
3.6 T0 / T4 DPLL INPUT CLOCK SELECTION	24
3.6.1 External Fast Selection (T0 only)	24
3.6.2 Forced Selection	25
3.6.3 Automatic Selection	25
3.7 SELECTED INPUT CLOCK MONITORING	26
3.7.1 T0 / T4 DPLL Locking Detection	26
3.7.1.1 Fast Loss	26
3.7.1.2 Coarse Phase Loss	26
3.7.1.3 Fine Phase Loss	26
3.7.1.4 Hard Limit Exceeding	26
3.7.2 Locking Status	26
3.7.3 Phase Lock Alarm (T0 only)	27
3.8 INPUT CLOCK SELECTION	28
3.8.1 Input Clock Validity	28
3.8.2 Selected Input Clock Switch	28
3.8.2.1 Revertive Switch	28
3.8.2.2 Non-Revertive Switch (T0 only)	29
3.8.3 Selected / Qualified Input Clocks Indication	29
3.9 SELECTED INPUT CLOCK STATUS VS. DPLL OPERATING MODE	30
3.9.1 T0 Selected Input Clock vs. DPLL Operating Mode	30
3.9.2 T4 Selected Input Clock vs. DPLL Operating Mode	32
3.10 T0 / T4 DPLL OPERATING MODE	33
3.10.1 T0 DPLL Operating Mode	33
3.10.1.1 Free-Run Mode	33
3.10.1.2 Pre-Locked Mode	33
3.10.1.3 Locked Mode	33

3.10.1.3.1	Temp-Holdover Mode	33
3.10.1.4	Lost-Phase Mode	33
3.10.1.5	Holdover Mode	34
3.10.1.5.1	Automatic Instantaneous	34
3.10.1.5.2	Automatic Slow Averaged	34
3.10.1.5.3	Automatic Fast Averaged	34
3.10.1.5.4	Manual	34
3.10.1.5.5	Holdover Frequency Offset Read	34
3.10.1.6	Pre-Locked2 Mode	34
3.10.2	T4 DPLL Operating Mode	34
3.10.2.1	Free-Run Mode	34
3.10.2.2	Locked Mode	34
3.10.2.3	Holdover Mode	35
3.11	T0 / T4 DPLL OUTPUT	36
3.11.1	PFD Output Limit	36
3.11.2	Frequency Offset Limit	36
3.11.3	PBO (T0 only)	36
3.11.4	Phase Offset Selection (T0 only)	36
3.11.5	Five Paths of T0 / T4 DPLL Outputs	36
3.11.5.1	T0 Path	36
3.11.5.2	T4 Path	37
3.12	T0 / T4 APLL	38
3.13	OUTPUT CLOCKS & FRAME SYNC SIGNALS	38
3.13.1	Output Clocks	38
3.13.2	Frame SYNC Output Signals	40
3.14	MASTER / SLAVE CONFIGURATION	43
3.15	INTERRUPT SUMMARY	44
3.16	T0 AND T4 SUMMARY	44
3.17	POWER SUPPLY FILTERING TECHNIQUES	45
4	TYPICAL APPLICATION	46
4.1	MASTER / SLAVE APPLICATION	46
5	MICROPROCESSOR INTERFACE	47
5.1	EPROM MODE	49
5.2	MULTIPLEXED MODE	50
5.3	INTEL MODE	52
5.4	MOTOROLA MODE	54
5.5	SERIAL MODE	56
6	JTAG	59
7	PROGRAMMING INFORMATION	60
7.1	REGISTER MAP	60
7.2	REGISTER DESCRIPTION	65
7.2.1	Global Control Registers	65
7.2.2	Interrupt Registers	74
7.2.3	Input Clock Frequency & Priority Configuration Registers	78
7.2.4	Input Clock Quality Monitoring Configuration & Status Registers	89
7.2.5	T0 / T4 DPLL Input Clock Selection Registers	100
7.2.6	T0 / T4 DPLL State Machine Control Registers	105
7.2.7	T0 / T4 DPLL & APLL Configuration Registers	107
7.2.8	Output Configuration Registers	121
7.2.9	PBO & Phase Offset Control Registers	128
7.2.10	Synchronization Configuration Registers	130
8	THERMAL MANAGEMENT	131
8.1	JUNCTION TEMPERATURE	131

8.2 EXAMPLE OF JUNCTION TEMPERATURE CALCULATION 131

8.3 HEATSINK EVALUATION 131

8.4 TQFP EPAD THERMAL RELEASE PATH 132

9 ELECTRICAL SPECIFICATIONS 133

9.1 ABSOLUTE MAXIMUM RATING 133

9.2 RECOMMENDED OPERATION CONDITIONS 133

9.3 I/O SPECIFICATIONS 134

9.3.1 CMOS Input / Output Port 134

9.3.2 PECL / LVDS Input / Output Port 135

9.3.2.1 PECL Input / Output Port 135

9.3.2.2 LVDS Input / Output Port 137

9.3.2.3 Single-Ended Input for Differential Input 138

9.4 JITTER PERFORMANCE 139

9.5 OUTPUT WANDER GENERATION 143

9.6 INPUT / OUTPUT CLOCK TIMING 144

9.7 OUTPUT CLOCK TIMING 146

PACKAGE DIMENSIONS..... 152

ORDERING INFORMATION..... 155

IDT CONFIDENTIAL



List of Tables

DATASHEET

Table 1: Pin Description	13
Table 2: Related Bit / Register in Chapter 3.2	18
Table 3: Related Bit / Register in Chapter 3.3	19
Table 4: Pre-Divider Functions	21
Table 5: Related Bit / Register in Chapter 3.5	23
Table 6: Input Clock Selection for T0 Path	24
Table 7: Input Clock Selection for T4 Path	24
Table 8: External Fast Selection	24
Table 9: Related Bit / Register in Chapter 3.6	25
Table 10: Coarse Phase Limit Programming (the selected input clock of 2 kHz, 4 kHz or 8 kHz)	26
Table 11: Coarse Phase Limit Programming (the selected input clock of other than 2 kHz, 4 kHz and 8 kHz)	26
Table 12: Related Bit / Register in Chapter 3.7	27
Table 13: Conditions of Qualified Input Clocks Available for T0 & T4 Selection	28
Table 14: Related Bit / Register in Chapter 3.8	29
Table 15: T0 DPLL Operating Mode Control	30
Table 16: T4 DPLL Operating Mode Control	32
Table 17: Related Bit / Register in Chapter 3.9	32
Table 18: Frequency Offset Control in Temp-Holdover Mode	33
Table 19: Frequency Offset Control in Holdover Mode	34
Table 20: Holdover Frequency Offset Read	34
Table 21: Related Bit / Register in Chapter 3.10	35
Table 22: Related Bit / Register in Chapter 3.11	37
Table 23: Related Bit / Register in Chapter 3.12	38
Table 24: Outputs on OUT1 ~ OUT5 if Derived from T0/T4 DPLL Outputs	38
Table 25: Outputs on OUT1 ~ OUT5 if Derived from T0/T4 APLL	39
Table 26: Synchronization Control	40
Table 27: Related Bit / Register in Chapter 3.13	42
Table 28: Device Master / Slave Control	43
Table 29: Related Bit / Register in Chapter 3.15	44
Table 30: Microprocessor Interface	47
Table 31: Microprocessor Interface Pins	48
Table 32: Access Timing Characteristics in EPROM Mode	49
Table 33: Read Timing Characteristics in Multiplexed Mode	50
Table 34: Write Timing Characteristics in Multiplexed Mode	51
Table 35: Read Timing Characteristics in Intel Mode	52
Table 36: Write Timing Characteristics in Intel Mode	53
Table 37: Read Timing Characteristics in Motorola Mode	54
Table 38: Write Timing Characteristics in Motorola Mode	55
Table 39: Read Timing Characteristics in Serial Mode	57
Table 40: Write Timing Characteristics in Serial Mode	58
Table 41: JTAG Timing Characteristics	59
Table 42: Register List and Map	60
Table 43: Power Consumption and Maximum Junction Temperature	131
Table 44: Thermal Data	131
Table 45: Absolute Maximum Rating	133
Table 46: Recommended Operation Conditions	133
Table 47: CMOS Input Port Electrical Characteristics	134
Table 48: CMOS Input Port with Internal Pull-Up Resistor Electrical Characteristics	134

Table 49: CMOS Input Port with Internal Pull-Down Resistor Electrical Characteristics 134

Table 50: CMOS Output Port Electrical Characteristics 134

Table 51: PECL Input / Output Port Electrical Characteristics 136

Table 52: LVDS Input / Output Port Electrical Characteristics 137

Table 53: Output Clock Jitter Generation (jitter measured on one differential output (OUT6 or OUT7) with all other outputs disabled) 139

Table 54: Output Clock Jitter Generation (jitter measured on one CMOS output (OUT1 - OUT5) with all other outputs disabled) 142

Table 55: Input/Output Clock Timing 3 145

Table 56: Output Clock Timing 147

IDT CONFIDENTIAL



List of Figures

DATASHEET

Figure 1. Functional Block Diagram	11
Figure 2. Pin Assignment (Top View)	12
Figure 3. Pre-Divider for An Input Clock	21
Figure 4. Input Clock Activity Monitoring	22
Figure 5. External Fast Selection	24
Figure 6. Qualified Input Clocks for Automatic Selection	25
Figure 7. T0 Selected Input Clock vs. DPLL Automatic Operating Mode	31
Figure 8. T4 Selected Input Clock vs. DPLL Automatic Operating Mode	32
Figure 9. On Target Frame Sync Input Signal Timing	40
Figure 10. 0.5 UI Early Frame Sync Input Signal Timing	40
Figure 11. 0.5 UI Late Frame Sync Input Signal Timing	41
Figure 12. 1 UI Late Frame Sync Input Signal Timing	41
Figure 13. 1 UI Late Frame Sync 2K/8K Pulse Input Signal Timing	41
Figure 14. On Target Frame Sync 2K/8K Pulse Input Signal Timing	41
Figure 15. Physical Connection Between Two Devices	43
Figure 16. IDT82V3389 Power Decoupling Scheme	45
Figure 17. Typical Application	46
Figure 18. EPROM Access Timing Diagram	49
Figure 19. Multiplexed Read Timing Diagram	50
Figure 20. Multiplexed Write Timing Diagram	51
Figure 21. Intel Read Timing Diagram	52
Figure 22. Intel Write Timing Diagram	53
Figure 23. Motorola Read Timing Diagram	54
Figure 24. Motorola Write Timing Diagram	55
Figure 25. Serial Read Timing Diagram (CLKE Asserted Low)	56
Figure 26. Serial Read Timing Diagram (CLKE Asserted High)	56
Figure 27. Serial Write Timing Diagram	57
Figure 28. JTAG Interface Timing Diagram	59
Figure 29. Assembly for Expose Pad thermal Release Path (Side View)	132
Figure 30. Recommended PECL Input Port Line Termination	135
Figure 31. Recommended PECL Output Port Line Termination	135
Figure 32. Recommended LVDS Input Port Line Termination	137
Figure 33. Recommended LVDS Output Port Line Termination	137
Figure 34. Example of Single-Ended Signal to Drive Differential Input	138
Figure 35. Output Wander Generation (TDEV)	143
Figure 36. Output Wander Generation (MTIE)	143
Figure 37. Input / Output Clock Timing	144
Figure 38. Output Clock Timing	146
Figure 39. 100-Pin EQG Package Dimensions (a) (in Millimeters)	152
Figure 40. 100-Pin EQG Package Dimensions (b) (in Millimeters)	153
Figure 41. EQG100 Recommended Land Pattern with Exposed Pad (in Millimeters)	154

FEATURES

HIGHLIGHTS

- The first single PLL chip:
 - Features 0.5 MHz to 560 Hz bandwidth
 - Provides node clock for ITU-T G.8261/G.8262 Synchronous Ethernet
 - Exceeds GR-253-CORE (OC-12) and ITU-T G.813 (STM-16/Option I) jitter generation requirements
 - Provides node clocks for Cellular and WLL base-station (GSM and 3G networks)
 - Provides clocks for DSL access concentrators (DSLAM), especially for Japan TCM-ISDN network timing based ADSL equipments

MAIN FEATURES

- Provides an integrated single-chip solution for Synchronous Equipment Timing Source, including Stratum 3, SMC, 4E and 4 clocks
- Employs DPLL and APLL to feature excellent jitter performance and minimize the number of the external components
- Integrates T0 DPLL and T4 DPLL; T4 DPLL locks independently or locks to T0 DPLL
- Supports Forced or Automatic operating mode switch controlled by an internal state machine; it supports Free-Run, Locked and Hold-over modes
- Supports programmable DPLL bandwidth (0.5 MHz to 560 Hz in 19 steps) and damping factor (1.2 to 20 in 5 steps)
- Supports 1.1×10^{-5} ppm absolute holdover accuracy and 4.4×10^{-8} ppm instantaneous holdover accuracy
- Supports PBO to minimize phase transients on T0 DPLL output to be no more than 0.61 ns
- Supports phase absorption when phase changes on T0 selected input clock are greater than a programmable limit over an interval of less than 0.1 seconds
- Supports programmable input-to-output phase offset adjustment
- Limits the phase and frequency offset of the outputs
- Supports manual and automatic selected input clock switch
- Supports automatic hitless selected input clock switch on clock failure

- Supports three types of input clock sources: recovered clock from STM-N or OC-n, PDH network synchronization timing and external synchronization reference timing
- Provides a 2 kHz, 4 kHz or 8 kHz frame sync input signal, and a 2 kHz and an 8 kHz frame sync output signals
- Provides 5 input clocks whose frequency cover from 2 kHz to 622.08 MHz
- Provides 5 output clocks whose frequency cover from 1 Hz to 622.08 MHz
- Provides output clocks for BITS, GPS, 3G, GSM, etc.
- Supports PECL/LVDS and CMOS input/output technologies
- Supports master clock calibration
- Supports Master/Slave application (two chips used together) to enable system protection against single chip failure
- Supports frequency monitor hysteresis
- Supports Telcordia GR-1244-CORE, GR-253-CORE, ITU-T G.812, ITU-T G.8262, ITU-T G.813 and ITU-T G.783

OTHER FEATURES

- Multiple microprocessor interface modes: EPROM, Multiplexed, Intel, Motorola and Serial
- IEEE 1149.1 JTAG Boundary Scan
- Single 3.3 V operation with 5 V tolerant CMOS I/Os
- 100-pin TQFP package, Green package options available

APPLICATIONS

- BITS / SSU
- SMC / SEC (SONET / SDH)
- DWDM cross-connect and transmission equipments
- Synchronous Ethernet equipments
- Central Office Timing Source and Distribution
- Core and access IP switches / routers
- Gigabit and Terabit IP switches / routers
- IP and ATM core switches and access equipments
- Cellular and WLL base-station node clocks
- Broadband and multi-service access equipments
- Any other telecom equipments that need synchronous equipment system timing

DESCRIPTION

The IDT82V3389 is an integrated, single-chip solution for the Synchronous Equipment Timing Source for Stratum 3, 4E, 4, EEC-Option 1, EEC-Option 2 and SMC clocks in SONET / SDH / Ethernet equipments, DWDM and Wireless base station, DSL concentrator, Router and Access Network applications.

The device supports three types of input clock sources: recovered clock from STM-N or OC-n, PDH network synchronization timing and external synchronization reference timing.

The device consists of T0 and T4 paths. The T0 path is a high quality and highly configurable path to provide system clock for node timing synchronization within a SONET / SDH network. The T4 path is simpler and less configurable for equipment synchronization. The T4 path locks independently from the T0 path or locks to the T0 path.

An input clock is automatically or manually selected for T0 and T4 each for DPLL locking. Both the T0 and T4 paths support three primary operating modes: Free-Run, Locked and Holdover. In Free-Run mode, the DPLL refers to the master clock. In Locked mode, the DPLL locks to the selected input clock. In Holdover mode, the DPLL resorts to the frequency data acquired in Locked mode. Whatever the operating mode is,

the DPLL gives a stable performance without being affected by operating conditions or silicon process variations.

If the DPLL outputs are processed by T0/T4 APLL, the outputs of the device will be in a better jitter/wander performance.

The device provides programmable DPLL bandwidths: 0.5 MHz to 560 Hz in 19 steps and damping factors: 1.2 to 20 in 5 steps. Different settings cover all SONET / SDH clock synchronization requirements.

A high stable input is required for the master clock in different applications. The master clock is used as a reference clock for all the internal circuits in the device. It can be calibrated within ± 741 ppm.

All the read/write registers are accessed through a microprocessor interface. The device supports five microprocessor interface modes: EPROM, Multiplexed, Intel, Motorola and Serial.

In general, the device can be used in Master/Slave application. In this application, two devices should be used together to enable system protection against single chip failure. See [Chapter 4 Typical Application](#) for details.

FUNCTIONAL BLOCK DIAGRAM

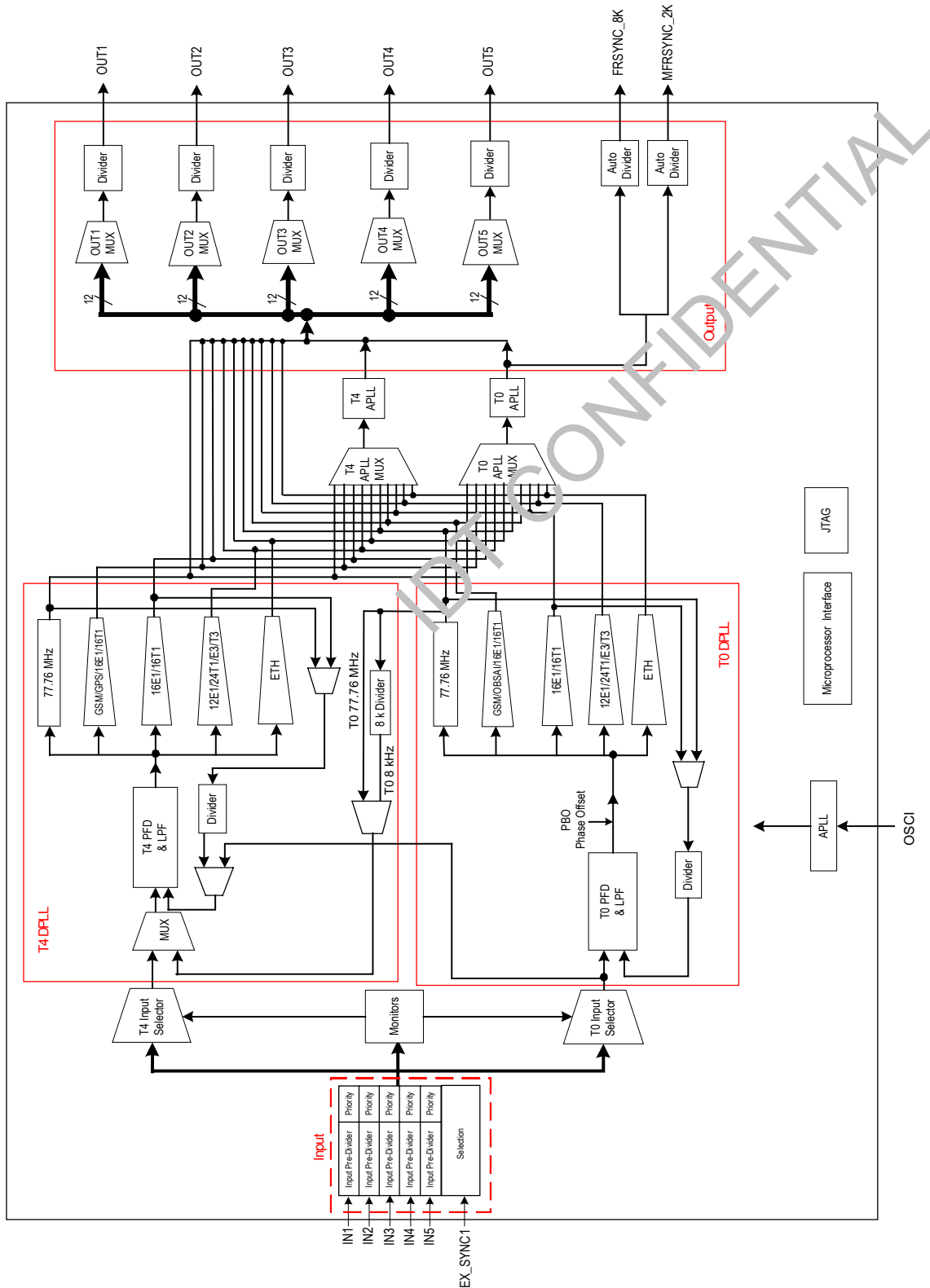

Figure 1. Functional Block Diagram

1 PIN ASSIGNMENT

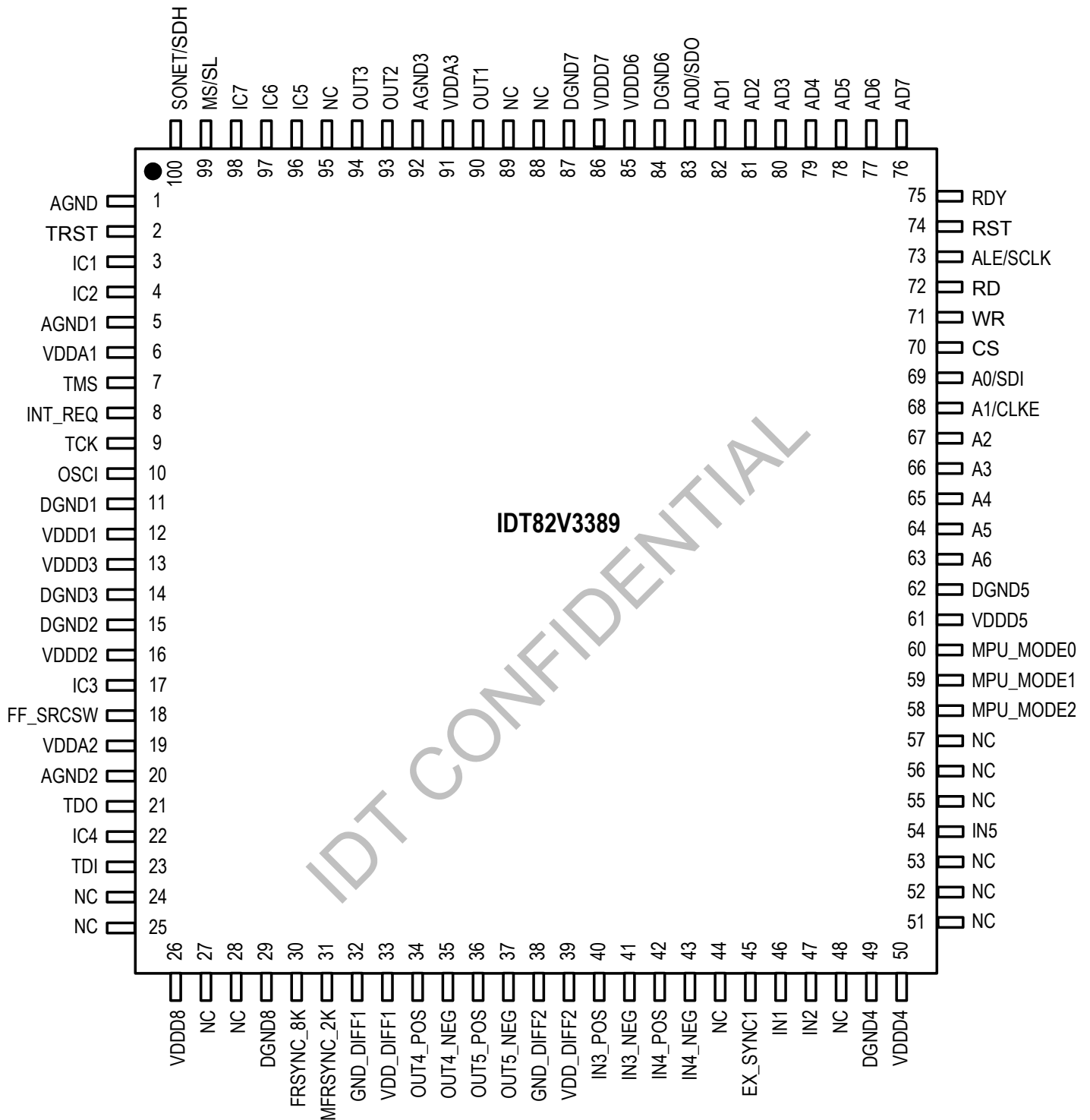

Figure 2. Pin Assignment (Top View)

2 PIN DESCRIPTION

Table 1: Pin Description

Name	Pin No.	I/O	Type	Description ¹
Global Control Signal				
OSCI	10	I	CMOS	OSCI: Crystal Oscillator Master Clock A nominal 12.8000 MHz clock provided by a crystal oscillator is input on this pin. It is the master clock for the device.
FF_SRCSW	18	I pull-down	CMOS	FF_SRCSW: External Fast Selection Enable During reset, this pin determines the default value of the EXT_SW bit (b4, 0BH) ² . The EXT_SW bit determines whether the External Fast Selection is enabled. High: The default value of the EXT_SW bit (b4, 0BH) is '1' (External Fast selection is enabled); Low: The default value of the EXT_SW bit (b4, 0BH) is '0' (External Fast selection is disabled). After reset, this pin selects an input clock pair for the T0 DPLL if the External Fast selection is enabled: High: Pair IN1 / IN3 is selected. Low: Pair IN2/ IN4 is selected. After reset, the input on this pin takes no effect if the External Fast selection is disabled.
MS/SL	99	I pull-up	CMOS	MS/SL: Master / Slave Selection This pin, together with the MS_SL_CTRL bit (b0, 13H), controls whether the device is configured as the Master or as the Slave. Refer to Chapter 3.14 Master / Slave Configuration for details. The signal level on this pin is reflected by the MASTER_SLAVE bit (b1, 09H).
SONET/SDH	100	I pull-down	CMOS	SONET/SDH: SONET / SDH Frequency Selection During reset, this pin determines the default value of the IN_SONET_SDH bit (b2, 09H): High: The default value of the IN_SONET_SDH bit is '1' (SONET); Low: The default value of the IN_SONET_SDH bit is '0' (SDH). After reset, the value on this pin takes no effect.
RST	74	I pull-up	CMOS	RST: Reset A low pulse of at least 50 μ s on this pin resets the device. After this pin is high, the device will still be held in reset state for 500 ms (typical).
Frame Synchronization Input Signal				
EX_SYNC1	45	I pull-down	CMOS	EX_SYNC1: External Sync Input 1 A 2 kHz, 4 kHz or 8 kHz signal is input on this pin.
Input Clock				
IN1	46	I pull-down	CMOS	IN1: Input Clock 1 A N x 2 kHz, N x 4 kHz, N x 8 kHz ³ , 1.544 MHz (SONET) / 2.048 MHz (SDH), 6.48 MHz, 19.44 MHz, 25.92 MHz, 38.88 MHz, 51.84 MHz, 77.76 MHz or 155.52 MHz clock is input on this pin.
IN2	47	I pull-down	CMOS	IN2: Input Clock 2 A N x 2 kHz, N x 4 kHz, N x 8 kHz ³ , 1.544 MHz (SONET) / 2.048 MHz (SDH), 6.48 MHz, 19.44 MHz, 25.92 MHz, 38.88 MHz, 51.84 MHz, 77.76 MHz or 155.52 MHz clock is input on this pin.
IN3_POS IN3_NEG	40 41	I	PECL/LVDS	IN3_POS / IN3_NEG: Positive / Negative Input Clock 3 A N x 2 kHz, N x 4 kHz, N x 8 kHz ³ , 1.544 MHz (SONET) / 2.048 MHz (SDH), 6.48 MHz, 19.44 MHz, 25.92 MHz, 38.88 MHz, 51.84 MHz, 77.76 MHz, 155.52 MHz, 156.25 MHz, 311.04 MHz or 622.08 MHz clock is differentially input on this pair of pins. Whether the clock signal is PECL or LVDS is automatically detected. Single-ended input for differential input is also supported. Refer to Chapter 9.3.2.3 Single-Ended Input for Differential Input .

Table 1: Pin Description (Continued)

Name	Pin No.	I/O	Type	Description ¹
IN4_POS IN4_NEG	42 43	I	PECL/LVDS	IN4_POS / IN4_NEG: Positive / Negative Input Clock 4 A N x 2 kHz, N x 4 kHz, N x 8 kHz ³ , 1.544 MHz (SONET) / 2.048 MHz (SDH), 6.48 MHz, 19.44 MHz, 25.92 MHz, 38.88 MHz, 51.84 MHz, 77.76 MHz, 155.52 MHz, 156.25 MHz, 311.04 MHz or 622.08 MHz clock is differentially input on this pair of pins. Whether the clock signal is PECL or LVDS is automatically detected. Single-ended input for differential input is also supported. Refer to Chapter 9.3.2.3 Single-Ended Input for Differential Input .
IN5	54	I pull-down	CMOS	IN5: Input Clock 5 A N x 2 kHz, N x 4 kHz, N x 8 kHz ³ , 1.544 MHz (SONET) / 2.048 MHz (SDH), 6.48 MHz, 19.44 MHz, 25.92 MHz, 38.88 MHz, 51.84 MHz, 77.76 MHz or 155.52 MHz clock is input on this pin. In Slave operation, the frequency of the T0 selected input clock IN5 is recommended to be 6.48 MHz.
Output Frame Synchronization Signal				
FRSYNC_8K	30	O	CMOS	FRSYNC_8K: 8 kHz Frame Sync Output An 8 kHz signal is output on this pin.
MFRSYNC_2K	31	O	CMOS	MFRSYNC_2K: 2 kHz Multiframe Sync Output A 2 kHz signal is output on this pin.
Output Clock				
OUT1	90	O	CMOS	OUT1: Output Clock 1 A 1 Hz, 400 Hz, 2 kHz, 8 kHz, 64 kHz, N x E1 ⁴ , N x T1 ⁵ , N x 13.0 MHz ⁶ , N x 3.84 MHz ⁷ , 5 MHz, 10 MHz, 20 MHz, 25 MHz, E3, T3, 6.48 MHz, 19.44 MHz, 25.92 MHz, 38.88 MHz, 51.84 MHz, 77.76 MHz, 125 MHz, 155.52 MHz or 156.25 MHz clock is output on this pin.
OUT2	93	O	CMOS	OUT2: Output Clock 2 A 1 Hz, 400 Hz, 2 kHz, 8 kHz, 64 kHz, N x E1 ⁴ , N x T1 ⁵ , N x 13.0 MHz ⁶ , N x 3.84 MHz ⁷ , 5 MHz, 10 MHz, 20 MHz, 25 MHz, E3, T3, 6.48 MHz, 19.44 MHz, 25.92 MHz, 38.88 MHz, 51.84 MHz, 77.76 MHz, 125 MHz, 155.52 MHz or 156.25 MHz clock is output on this pin.
OUT3	94	O	CMOS	OUT3: Output Clock 3 A 1 Hz, 400 Hz, 2 kHz, 8 kHz, 64 kHz, N x E1 ⁴ , N x T1 ⁵ , N x 13.0 MHz ⁶ , N x 3.84 MHz ⁷ , 5 MHz, 10 MHz, 20 MHz, 25 MHz, E3, T3, 6.48 MHz, 19.44 MHz, 25.92 MHz, 38.88 MHz, 51.84 MHz, 77.76 MHz, 125 MHz, 155.52 MHz or 156.25 MHz clock is output on this pin.
OUT4_POS OUT4_NEG	34 35	O	PECL/LVDS	OUT4_POS / OUT4_NEG: Positive / Negative Output Clock 4 A 1 Hz, 400 Hz, 2 kHz, 8 kHz, 64 kHz, N x E1 ⁴ , N x T1 ⁵ , N x 13.0 MHz ⁶ , N x 3.84 MHz ⁷ , 5 MHz, 10 MHz, 20 MHz, 25 MHz, E3, T3, 6.48 MHz, 19.44 MHz, 25.92 MHz, 38.88 MHz, 51.84 MHz, 77.76 MHz, 125 MHz, 155.52 MHz, 156.25 MHz, 311.04 MHz, 312.5 MHz, 622.08 MHz or 625 MHz clock is differentially output on this pair of pins.
OUT5_POS OUT5_NEG	36 37	O	PECL/LVDS	OUT5_POS / OUT5_NEG: Positive / Negative Output Clock 5 A 1 Hz, 400 Hz, 2 kHz, 8 kHz, 64 kHz, N x E1 ⁴ , N x T1 ⁵ , N x 13.0 MHz ⁶ , N x 3.84 MHz ⁷ , 5 MHz, 10 MHz, 20 MHz, 25 MHz, E3, T3, 6.48 MHz, 19.44 MHz, 25.92 MHz, 38.88 MHz, 51.84 MHz, 77.76 MHz, 125 MHz, 155.52 MHz, 156.25 MHz, 311.04 MHz, 312.5 MHz, 622.08 MHz or 625 MHz clock is differentially output on this pair of pins.
Microprocessor Interface				
CS	70	I/O pull-up	CMOS	CS: Chip Selection In EPROM mode, this pin is an output. In Multiplexed, Intel, Motorola and Serial modes, this pin is an input. A transition from high to low must occur on this pin for each read or write operation and this pin should remain low until the operation is over.
INT_REQ	8	O	CMOS	INT_REQ: Interrupt Request This pin is used as an interrupt request. The output characteristics are determined by the HZ_EN bit (b1, 0CH) and the INT_POL bit (b0, 0CH).

Table 1: Pin Description (Continued)

Name	Pin No.	I/O	Type	Description ¹
MPU_MODE0 MPU_MODE1 MPU_MODE2	60 59 58	I pull-down	CMOS	<p>MPU_MODE[2:0]: Microprocessor Interface Mode Selection The device supports five microprocessor interface modes: EPROM, Multiplexed, Intel, Motorola and Serial. During reset, these pins determine the default value of the MPU_SEL_CNFG[2:0] bits (b2~0, 7FH) as follows: 001 (EPROM mode); 010 (Multiplexed mode); 011 (Intel mode); 100 (Motorola mode); 101 (Serial mode); 110 - 111 (Reserved). After reset, these pins are general purpose inputs. The microprocessor interface mode is selected by the MPU_SEL_CNFG[2:0] bits (b2~0, 7FH). After reset de-assertion, wait 10μs for the mode to be active. The value of these pins is always reflected by the MPU_PIN_STS[2:0] bits (b2~0, 02H).</p>
A0 / SDI A1 / CLKE A2 A3 A4 A5 A6	69 68 67 66 65 64 63	I/O pull-down	CMOS	<p>A[6:0]: Address Bus In EPROM mode, these pins are outputs. They are the address bus of the EPROM interface. Intel and Motorola modes, these pins are inputs, they are the address bus of the microprocessor interface. SDI: Serial Data Input In Serial mode, this pin is used as the serial data input. Address and data on this pin are serially clocked into the device on the rising edge of SCLK. CLKE: SCLK Active Edge Selection In Serial mode, this pin is an input, it selects the active edge of SCLK to update the SDO: High - The falling edge; Low - The rising edge. In Multiplexed mode, A0/SDI, A1/CLKE and A[6:2] pins should be connected to ground. In Serial mode, A[6:2] pins should be connected to ground. See Table 31 for details.</p>
AD0 / SDO AD1 AD2 AD3 AD4 AD5 AD6 AD7	83 82 81 80 79 78 77 76	I/O pull-down	CMOS	<p>AD[7:0]: Address / Data Bus In EPROM, Intel and Motorola modes, these pins are the bi-directional data bus of the microprocessor interface. In Multiplexed mode, these pins are the bi-directional address/data bus of the microprocessor interface. SDO: Serial Data Output In Serial mode, this pin is used as the serial data output. Data on this pin is serially clocked out of the device on the active edge of SCLK. In Serial mode, AD[7:1] pins should be connected to ground.</p>
WR	71	I pull-up	CMOS	<p>WR: Write Operation In Multiplexed and Intel modes, this pin is asserted low to initiate a write operation. In Motorola mode, this pin is asserted low to initiate a write operation or asserted high to initiate a read operation. In EPROM and Serial modes, this pin should be connected to ground.</p>

Table 1: Pin Description (Continued)

Name	Pin No.	I/O	Type	Description ¹
RD	72	I pull-up	CMOS	RD: Read Operation In Multiplexed and Intel modes, this pin is asserted low to initiate a read operation. In EPROM, Motorola and Serial modes, this pin should be connected to ground.
ALE / SCLK	73	I pull-down	CMOS	ALE: Address Latch Enable In Multiplexed mode, the address on AD[7:0] pins is sampled into the device on the falling edge of ALE. SCLK: Shift Clock In Serial mode, a shift clock is input on this pin. Data on SDI is sampled by the device on the rising edge of SCLK. Data on SDO is updated on the active edge of SCLK. The active edge is determined by the CLKE. In EPROM, Intel and Motorola modes, this pin should be connected to ground.
RDY	75	O	CMOS	RDY: Ready/Data Acknowledge In Multiplexed and Intel modes, a high level on this pin indicates that a read/write cycle is completed. A low level on this pin indicates that wait state must be inserted. In Motorola mode, a low level on this pin indicates that valid information on the data bus is ready for a read operation or acknowledges the acceptance of the written data during a write operation. In EPROM and Serial modes, this pin should be connected to ground.
JTAG (per IEEE 1149.1)				
TRST	2	I pull-down	CMOS	TRST: JTAG Test Reset (Active Low) A low signal on this pin resets the JTAG test port. This pin should be connected to ground when JTAG is not used.
TMS	7	I pull-up	CMOS	TMS: JTAG Test Mode Select The signal on this pin controls the JTAG test performance and is sampled on the rising edge of TCK.
TCK	9	I pull-down	CMOS	TCK: JTAG Test Clock The clock for the JTAG test is input on this pin. TDI and TMS are sampled on the rising edge of TCK and TDO is updated on the falling edge of TCK. If TCK is idle at a low level, all stored-state devices contained in the test logic will indefinitely retain their state.
TDI	23	I pull-up	CMOS	TDI: JTAG Test Data Input The test data is input on this pin. It is clocked into the device on the rising edge of TCK.
TDO	21	O	CMOS	TDO: JTAG Test Data Output The test data is output on this pin. It is clocked out of the device on the falling edge of TCK. TDO pin outputs a high impedance signal except during the process of data scanning. This pin can indicate the interrupt of T0 selected input clock fail, as determined by the LOS_FLAG_ON_TDO bit (b6, 0BH). Refer to Chapter 3.8.1 Input Clock Validity for details.
Power & Ground				
VDDD1	12	Power	-	VDDn: 3.3 V Digital Power Supply VDDn connections should be connected using the recommended decoupling scheme shown in Figure 16 .
VDDD2	16			
VDDD3	13			
VDDD4	50			
VDDD5	61			
VDDD6	85			
VDDD7	86			

Table 1: Pin Description (Continued)

Name	Pin No.	I/O	Type	Description ¹
VDDA1	6	Power	-	VDDAn: 3.3 V Analog Power Supply VDDAn connections should be connected using the recommended decoupling scheme shown in Figure 16 .
VDDA2	19			
VDDA3	91			
VDDD8	26	Power	-	VDDD8: 3.3 V Digital Power Supply
VDD_DIFF1	33	Power	-	VDD_DIFF1: 3.3 V Power Supply for OUT4
VDD_DIFF2	39	Power	-	VDD_DIFF2: 3.3 V Power Supply for OUT5
DGND1	11	Ground	-	DGNDn: Digital Ground
DGND2	15			
DGND3	14			
DGND4	49			
DGND5	62			
DGND6	84			
DGND7	87			
AGND1	5	Ground	-	AGNDn: Analog Ground
AGND2	20			
AGND3	92			
GND_DIFF1	32	Ground	-	GND_DIFF: Ground for OUT4
GND_DIFF2	38	Ground	-	GND_DIFF: Ground for OUT5
DGND8	29	Ground	-	DGND8: Digital Ground
AGND	1	Ground	-	AGND: Analog Ground
Others				
IC1	3	-	-	IC: Internally Connected Internal Use. These pins should be left open for normal operation.
IC2	4			
IC3	17			
IC4	22			
IC5	96			
IC6	97			
IC7	98			
NC	24, 25, 27, 28, 44, 48, 51, 52, 53, 55, 56, 57, 88, 89, 95	-	-	NC: Not Connected

Note:

- All the unused input pins should be connected to ground; the output of all the unused output pins are don't-care.
- The contents in the brackets indicate the position of the register bit/bits.
- N x 8 kHz: $1 \leq N \leq 19440$.
- N x E1: N = 1, 2, 3, 4, 6, 8, 12, 16, 24, 32, 48, 64.
- N x T1: N = 1, 2, 3, 4, 6, 8, 12, 16, 24, 32, 48, 64, 96.
- N x 13.0 MHz: N = 1, 2, 4.
- N x 3.84 MHz: N = 1, 2, 4, 8, 16, 10, 20, 40.

3 FUNCTIONAL DESCRIPTION

3.1 RESET

The reset operation resets all registers and state machines to their default value or status.

After power on, the device must be reset for normal operation.

For a complete reset, the RST pin must be asserted low for at least 50 μ s. After the RST pin is pulled high, the device will still be in reset state for 500 ms (typical). If the RST pin is held low continuously, the device remains in reset state.

3.2 MASTER CLOCK

A nominal 12.8000 MHz clock, provided by a crystal oscillator, is input on the OSC1 pin. This clock is provided for the device as a master clock. The master clock is used as a reference clock for all the internal circuits. A better active edge of the master clock is selected by the OSC_EDGE bit to improve jitter and wander performance.

In fact, an offset from the nominal frequency may input on the OSC1 pin. This offset can be compensated by setting the NOMINAL_FREQ_VALUE[23:0] bits. The calibration range is within ± 741 ppm.

The performance of the master clock should meet GR-1244-CORE, GR-253-CORE, ITU-T G.812 and G.813 criteria.

Table 2: Related Bit / Register in Chapter 3.2

Bit	Register	Address (Hex)
NOMINAL_FREQ_VALUE[23:0]	NOMINAL_FREQ[23:16]_CNFG, NOMINAL_FREQ[15:8]_CNFG, NOMINAL_FREQ[7:0]_CNFG	06, 05, 04
OSC_EDGE	DIFFERENTIAL_IN_OUT_OSC_CNFG	0A

3.3 INPUT CLOCKS & FRAME SYNC SIGNAL

Altogether 5 clocks and 1 frame sync signal are input to the device.

3.3.1 INPUT CLOCKS

The device provides 5 input clock ports.

According to the input port technology, the input ports support the following technologies:

- PECL/LVDS
- CMOS

According to the input clock source, the following clock sources are supported:

- T1: Recovered clock from STM-N or OC-n
- T2: PDH network synchronization timing
- T3: External synchronization reference timing

IN1, IN2 and IN5 support CMOS input signal only and the clock sources can be from T1, T2 or T3.

IN3 and IN4 support PECL/LVDS input signal and automatically detect whether the signal is PECL or LVDS. The clock sources can be from T1, T2 or T3.

For SDH and SONET networks, the default frequency is different. SONET / SDH frequency selection is controlled by the IN_SONET_SDH bit. During reset, the default value of the IN_SONET_SDH bit is determined by the SONET/SDH pin: high for SONET and low for SDH. After reset, the input signal on the SONET/SDH pin takes no effect.

IDT82V3389 supports single-ended input for differential input. Refer to [Chapter 9.3.2.3 Single-Ended Input for Differential Input](#).

3.3.2 FRAME SYNC INPUT SIGNALS

A 2 kHz, 4 kHz or 8 kHz frame sync signal is input on the EX_SYNC1 pin. It is a CMOS input. The input frequency should match the setting in the SYNC_FREQ[1:0] bits.

The frame sync input signal is used for frame sync output signal synchronization. Refer to [Chapter 3.13.2 Frame SYNC Output Signals](#) for details.

Table 3: Related Bit / Register in Chapter 3.3

Bit	Register	Address (Hex)
IN_SONET_SDH	INPUT_MODE_CNFG	09
SYNC_FREQ[1:0]		

3.4 INPUT CLOCK PRE-DIVIDER

Each input clock is assigned an internal Pre-Divider. The Pre-Divider is used to divide the clock frequency down to the internal DPLL's required input frequency, which is no more than 38.88 MHz.

For IN1 ~ IN5, the DPLL required frequency is set by the corresponding IN_FREQ[3:0] bits.

Each Pre-Divider consists of a DivN Divider and a Lock 8k Divider. IN3 and IN4 also include an HF (High Frequency) Divider. Figure 3 shows a block diagram of the pre-dividers for an input clock and Table 4 shows the Pre-Divider Functions.

When the Lock 8k Divider is used, the input clock is divided down to 8 kHz internally; the PRE_DIVN_VALUE [14:0] bits are not required. Lock 8k Divider can be used for 1.544 MHz, 2.048 MHz, 6.48 MHz, 19.44 MHz, 25.92 MHz or 38.88 MHz input clock frequency and the corresponding IN_FREQ[3:0] bits should be set to match the input frequency.

For 2 kHz, 4 kHz or 8 kHz input clock frequency only, the Pre-Divider should be bypassed by setting IN3_DIV[1:0] bits / IN4_DIV[1:0] bits = 0, DIRECT_DIV bit = 0, and LOCK_8K bit = 0. The corresponding IN_FREQ[3:0] bits should be set to match the input frequency. The input clock can be inverted, as determined by the IN_2K_4K_8K_INV bit.

The HF Divider, which is only available for IN3 and IN4, should be used when the input clock is higher than (>) 155.52 MHz. The input clock can be divided by 4, 5 or can bypass the HF Divider, as determined by the IN3_DIV[1:0]/IN4_DIV[1:0] bits correspondingly.

Either the DivN Divider or the Lock 8k Divider can be used or both can be bypassed, as determined by the DIRECT_DIV bit and the LOCK_8K bit.

When the DivN Divider is used for INn (1 ≤ n ≤ 5), the division factor setting should observe the following order:

1. Select an input clock by the PRE_DIV_CH_VALUE[3:0] bits;
2. Write the lower eight bits of the division factor to the PRE_DIVN_VALUE[7:0] bits;
3. Write the higher eight bits of the division factor to the PRE_DIVN_VALUE[14:8] bits.

Once the division factor is set for the input clock selected by the PRE_DIV_CH_VALUE[3:0] bits, it is valid until a different division factor is set for the same input clock. The division factor is calculated as follows:

$$\text{Division Factor} = (\text{the frequency of the clock input to the DivN Divider} \div \text{the frequency of the DPLL required clock set by the IN_FREQ[3:0] bits}) - 1$$

The DivN Divider can only divide the input clock whose frequency is less than or equal to (≤) 155.52 MHz.

The Pre-Divider configuration and the division factor setting depend on the input clock on one of the IN1 ~ IN5 pins and the DPLL required clock. Here is an example:

The input clock on the IN4 pin is 622.08 MHz; the DPLL required clock is 6.48 MHz by programming the IN_FREQ[3:0] bits of register IN4 to '0010'. Do the following step by step to divide the input clock:

1. Use the HF Divider to divide the clock down to 155.52 MHz:
622.08 ÷ 155.52 = 4, so set the IN4_DIV[1:0] bits to '01';
2. Use the DivN Divider to divide the clock down to 6.48 MHz:
Set the PRE_DIV_CH_VALUE[3:0] bits to '0110';
Set the DIRECT_DIV bit in Register IN4_CNFG to '1' and the LOCK_8K bit in Register IN4_CNFG to '0';
155.52 ÷ 6.48 = 24; 24 - 1 = 23, so set the PRE_DIVN_VALUE[14:0] bits to '10111'.

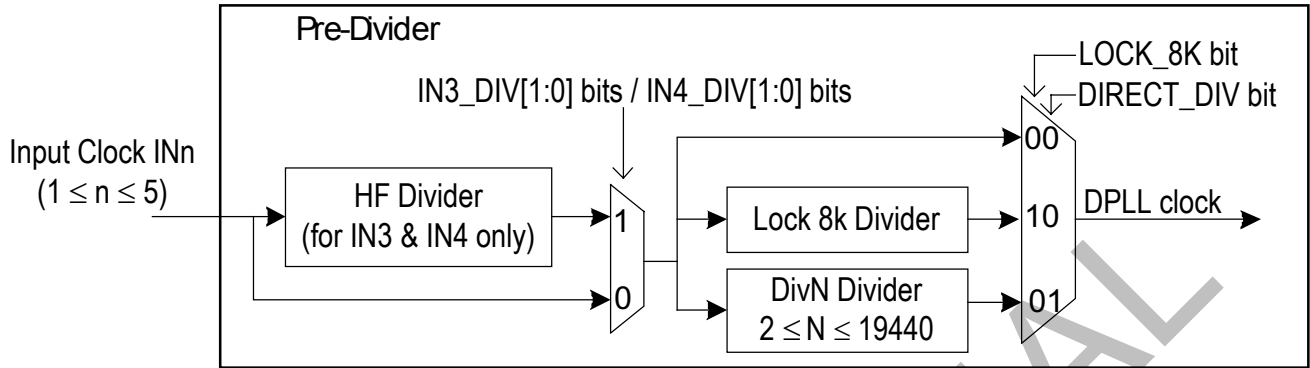

Figure 3. Pre-Divider for An Input Clock

Table 4: Pre-Divider Functions

Pre-Divider	Input Clock INn frequency	Control Register	Register/ Address ¹
HF- Divider	>155.52 MHz	IN3_DIV[1:0] IN4_DIV[1:0]	IN3_IN4_HF_DIV_CNFG (18)
Divider Bypassed	2KHz, 4KHz, 8KHz, 1.544 MHz, 2.048 MHz, 6.48 MHz, 19.44 MHz, 25.92 MHz or 38.88 MHz	IN_FREQ[3:0] – set to match input Clock INn frequency. LOCK_8K= 0'b; DIRECT_DIV= 0'b (Bypass Dividers)	IN1_CNFG ~ IN5_CNFG (16 ~ 17, 19 ~ 1A, 1F)
Lock 8K Divider	1.544 MHz, 2.048 MHz, 6.48 MHz, 19.44 MHz, 25.92 MHz or 38.88 MHz	IN_FREQ[3:0] – set to match input Clock INn frequency. LOCK_8K= 1'b; DIRECT_DIV= 0'b (select Lock 8k Divider)	IN1_CNFG ~ IN5_CNFG (16 ~ 17, 19 ~ 1A, 1F)
DivN	Nx8kHz (2 ≤ N ≤ 19440) Example: 25 MHz = 3125 x 8kHz	LOCK_8K= 0'b; DIRECT_DIV= 1'b (select DivN Divider) IN_FREQ[3:0] – set to the DPLL required frequency. ('0000': 8 kHz (default)) PRE_DIV_CH_VALUE[3:0] PRE_DIVN_VALUE[14:0] Example: 25 MHz = 3125 x 8kHz Division Factor = 3125 -1= 3124 Dec (or 0C34h) PRE_DIVN_VALUE[7:0]= 34h PRE_DIVN_VALUE[14:8]= 0Ch	IN1_CNFG ~ IN5_CNFG (16 ~ 17, 19 ~ 1A, 1F) PRE_DIV_CH_CNFG (23) PRE_DIVN[14:8]_CNFG (25), PRE_DIVN[7:0]_CNFG (24)

Note 1: Please see registers description for details.

3.5 INPUT CLOCK QUALITY MONITORING

The qualities of all the input clocks are always monitored in the following aspects:

- Activity
- Frequency

Activity and frequency monitoring are conducted on all the input clocks.

The qualified clocks are available for T0/T4 DPLL selection. The T0 and T4 selected input clocks have to be monitored further. Refer to [Chapter 3.7 Selected Input Clock Monitoring](#) for details.

3.5.1 ACTIVITY MONITORING

Activity is monitored by using an internal leaky bucket accumulator, as shown in [Figure 4](#).

Each input clock is assigned an internal leaky bucket accumulator. The input clock is monitored for each period of 128 ms and the internal leaky bucket accumulator increases by 1 when an event is detected; it decreases by 1 if no event is detected within the period set by the decay rate. The event is that an input clock drifts outside ($>$) ± 500 ppm with respect to the master clock within a 128 ms period.

There are four configurations (0 - 3) for a leaky bucket accumulator. The leaky bucket configuration for an input clock is selected by the cor-

responding BUCKET_SEL[1:0] bits. Each leaky bucket configuration consists of four elements: upper threshold, lower threshold, bucket size and decay rate.

The bucket size is the capability of the accumulator. If the number of the accumulated events reaches the bucket size, the accumulator will stop increasing even if further events are detected. The upper threshold is a point above which a no-activity alarm is raised. The lower threshold is a point below which the no-activity alarm is cleared. The decay rate is a certain period during which the accumulator decreases by 1 if no event is detected.

The leaky bucket configuration is programmed by one of four groups of register bits: the BUCKET_SIZE_n_DATA[7:0] bits, the UPPER_THRESHOLD_n_DATA[7:0] bits, the LOWER_THRESHOLD_n_DATA[7:0] bits and the DECAY_RATE_n_DATA[1:0] bits respectively; 'n' is 3.

The no-activity alarm status of the input clock is indicated by the INn_NO_ACTIVITY_ALARM bit ($1 \leq n \leq 5$).

The input clock with a no-activity alarm is disqualified for clock selection for T0/T4 DPLL.

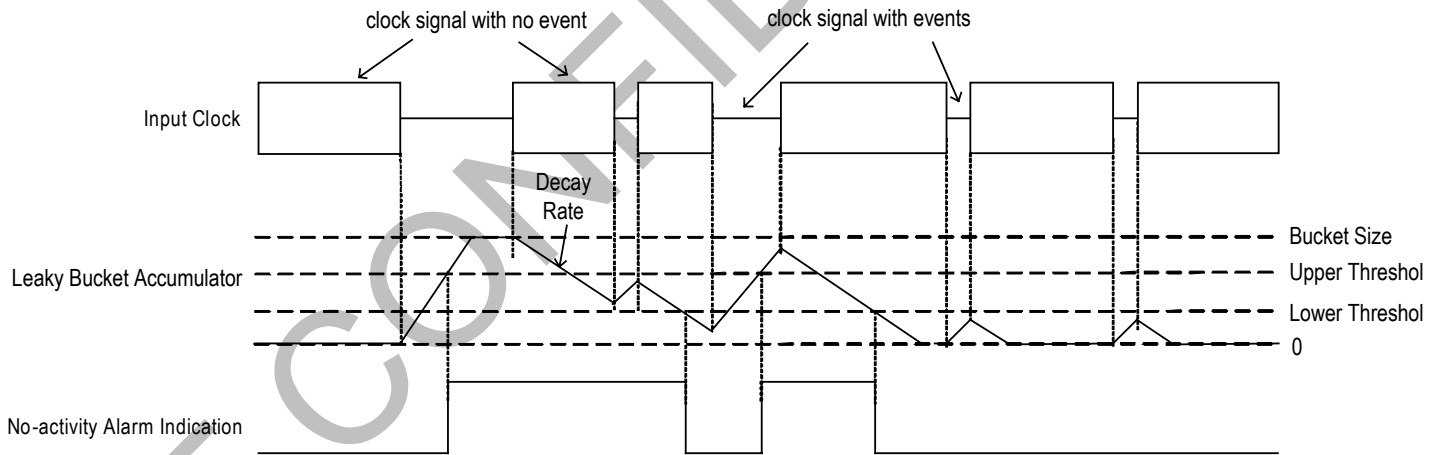

Figure 4. Input Clock Activity Monitoring

3.5.2 FREQUENCY MONITORING

Frequency is monitored by comparing the input clock with a reference clock. The reference clock can be derived from the master clock or the output of T0 DPLL, as determined by the `FREQ_MON_CLK` bit.

A frequency hard alarm threshold is set for frequency monitoring. It has two thresholds, rejecting threshold and accepting threshold, which are set in `HARD_FREQ_MON_THRESHOLD[7:0]`. If the `FREQ_MON_HARD_EN` bit is '1', a frequency hard alarm is raised when the frequency of the input clock with respect to the reference clock is above the hard alarm rejecting threshold; the alarm is cleared when the frequency is below the hard alarm accepting threshold.

The frequency hard alarm accepting threshold can be calculated as follows:

$$\text{Frequency Hard Alarm Accepting Threshold (ppm)} = (\text{HARD_FREQ_MON_THRESHOLD}[7:4] + 1) \times \text{FREQ_MON_FACTOR}[3:0] \text{ (b3~0)}$$

The frequency hard alarm rejecting threshold can be calculated as follows:

$$\text{Frequency Hard Alarm Rejecting Threshold (ppm)} = (\text{ALL_FREQ_HARD_THRESHOLD}[3:0] + 1) \times \text{FREQ_MON_FACTOR}[3:0]$$

If the `FREQ_MON_HARD_EN` bit is '1', the frequency hard alarm status of the input clock is indicated by the `INn_FREQ_HARD_ALARM` bit ($1 \leq n \leq 5$). When the `FREQ_MON_HARD_EN` bit is '0', no frequency hard alarm is raised even if the input clock is above the frequency hard alarm rejecting threshold.

The input clock with a frequency hard alarm is disqualified for clock selection for T0/T4 DPLL.

In addition, if the input clock is 2 kHz, 4 kHz or 8 kHz, its clock edges with respect to the reference clock are monitored. If any edge drifts outside $\pm 5\%$, the input clock is disqualified for clock selection for T0/T4 DPLL. The input clock is qualified if any edge drifts inside $\pm 5\%$. This function is supported only when the `IN_NOISE_WINDOW` bit is '1'.

The frequency of each input clock with respect to the reference clock can be read by doing the following step by step:

1. Select an input clock by setting the `IN_FREQ_READ_CH[3:0]` bits;
2. Read the value in the `IN_FREQ_VALUE[7:0]` bits and calculate as follows:

$$\text{Input Clock Frequency (ppm)} = \text{IN_FREQ_VALUE}[7:0] \times \text{FREQ_MON_FACTOR}[3:0]$$

Note that the value set by the `FREQ_MON_FACTOR[3:0]` bits depends on the application.

Table 5: Related Bit / Register in Chapter 3.5

Bit	Register	Address (Hex)
<code>BUCKET_SIZE_n_DATA[7:0]</code> (n = 3)	<code>BUCKET_SIZE_3_CNFG</code>	3F
<code>UPPER_THRESHOLD_n_DATA[7:0]</code> (n = 3)	<code>UPPER_THRESHOLD_3_CNFG</code>	3D
<code>LOWER_THRESHOLD_n_DATA[7:0]</code> (n = 3)	<code>LOWER_THRESHOLD_3_CNFG</code>	3E
<code>DECAY_RATE_n_DATA[1:0]</code> (n = 3)	<code>DECAY_RATE_3_CNFG</code>	40
<code>BUCKET_SEL[1:0]</code>	<code>IN1_CNFG ~ IN5_CNFG</code>	16 ~ 17, 19 ~ 1A, 1F
<code>INn_NO_ACTIVITY_ALARM</code> ($1 \leq n \leq 5$)	<code>IN1_IN2_STS, IN3_IN4_STS, IN5_STS</code>	44~ 45, 48
<code>INn_FREQ_HARD_ALARM</code> ($1 \leq n \leq 5$)		
<code>FREQ_MON_CLK</code>	<code>MON_SW_PBO_CNFG</code>	0B
<code>FREQ_MON_HARD_EN</code>		
<code>ALL_FREQ_HARD_THRESHOLD[7:0]</code>	<code>ALL_FREQ_MON_THRESHOLD_CNFG</code>	2F
<code>FREQ_MON_FACTOR[3:0]</code>	<code>FREQ_MON_FACTOR_CNFG</code>	2E
<code>IN_NOISE_WINDOW</code>	<code>PHASE_MON_PBO_CNFG</code>	78
<code>IN_FREQ_READ_CH[3:0]</code>	<code>IN_FREQ_READ_CH_CNFG</code>	41
<code>IN_FREQ_VALUE[7:0]</code>	<code>IN_FREQ_READ_STS</code>	42

3.6 T0 / T4 DPLL INPUT CLOCK SELECTION

An input clock is selected for T0 DPLL and for T4 DPLL respectively.

For T0 path, the EXT_SW bit and the T0_INPUT_SEL[3:0] bits determine the input clock selection, as shown in Table 6:

Table 6: Input Clock Selection for T0 Path

Control Bits		Input Clock Selection
EXT_SW	T0_INPUT_SEL[3:0]	
1	don't-care	External Fast selection
0	other than 0000	Forced selection
	0000	Automatic selection

For T4 path, the T4 DPLL may lock to a T0 DPLL output or lock independently from T0 path, as determined by the T4_LOCK_T0 bit. When the T4 DPLL locks to the T0 DPLL output, the T4 selected input clock is a 77.76 MHz or 8 kHz signal from the T0 DPLL 77.76 MHz path (refer to Chapter 3.11.5.1 T0 Path), as determined by the T0_FOR_T4 bit. When the T4 path locks independently from the T0 path, the T4 DPLL input clock selection is determined by the T4_INPUT_SEL[3:0] bits. Refer to Table 7:

Table 7: Input Clock Selection for T4 Path

Control Bits - T4_INPUT_SEL[3:0]	Input Clock Selection
other than 0000	Forced selection
0000	Automatic selection

External Fast selection is done between IN1/IN3 and IN2/IN4 pairs.

Forced selection is done by setting the related registers.

Automatic selection is done based on the results of input clocks quality monitoring and the related registers configuration.

Table 8: External Fast Selection

Control Pin & Bits			Selected Input Clock
FF_SRCSW (after reset)	IN1_SEL_PRIORITY[3:0]	IN2_SEL_PRIORITY[3:0]	
high	0000	don't-care	IN3
	other than 0000		IN1
low	don't-care	0000	IN4
		other than 0000	IN2

The selected input clock is attempted to be locked in T0/T4 DPLL.

3.6.1 EXTERNAL FAST SELECTION (T0 ONLY)

The External Fast selection is supported by T0 path only. In External Fast selection, only IN1/IN3 and IN2/IN4 pairs are available for selection. Refer to Figure 5. The results of input clocks quality monitoring (refer to Chapter 3.5 Input Clock Quality Monitoring) do not affect input clock selection.

The T0 input clock selection is determined by the FF_SRCSW pin after reset (this pin determines the default value of the EXT_SW bit during reset, refer to Chapter 2 Pin Description), the IN1_SEL_PRIORITY[3:0] bits and the IN2_SEL_PRIORITY[3:0] bits, as shown in Figure 5 and Table 8:

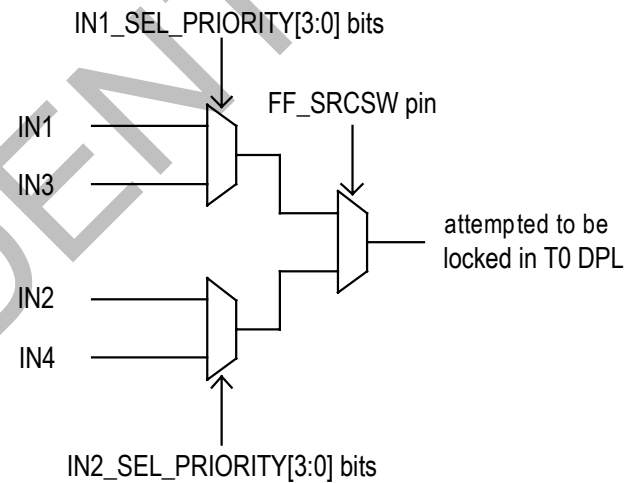

Figure 5. External Fast Selection

3.6.2 FORCED SELECTION

In Forced selection, the selected input clock is set by the T0_INPUT_SEL[3:0] / T4_INPUT_SEL[3:0] bits. The results of input clocks quality monitoring (refer to Chapter 3.5 Input Clock Quality Monitoring) do not affect the input clock selection.

3.6.3 AUTOMATIC SELECTION

In Automatic selection, the input clock selection is determined by its validity, priority and locking allowance configuration. The validity

depends on the results of input clock quality monitoring (refer to Chapter 3.5 Input Clock Quality Monitoring). Locking allowance is configured by the corresponding INn_VALID bit(1 ≤ n ≤ 5). Refer to Figure 6. In all the qualified input clocks, the one with the highest priority is selected. The priority is set by the corresponding INn_SEL_PRIORITY[3:0] bits (1 ≤ n ≤ 5). If more than one qualified input clock INn is available and has the same priority, the input clock with the smallest 'n' is selected.

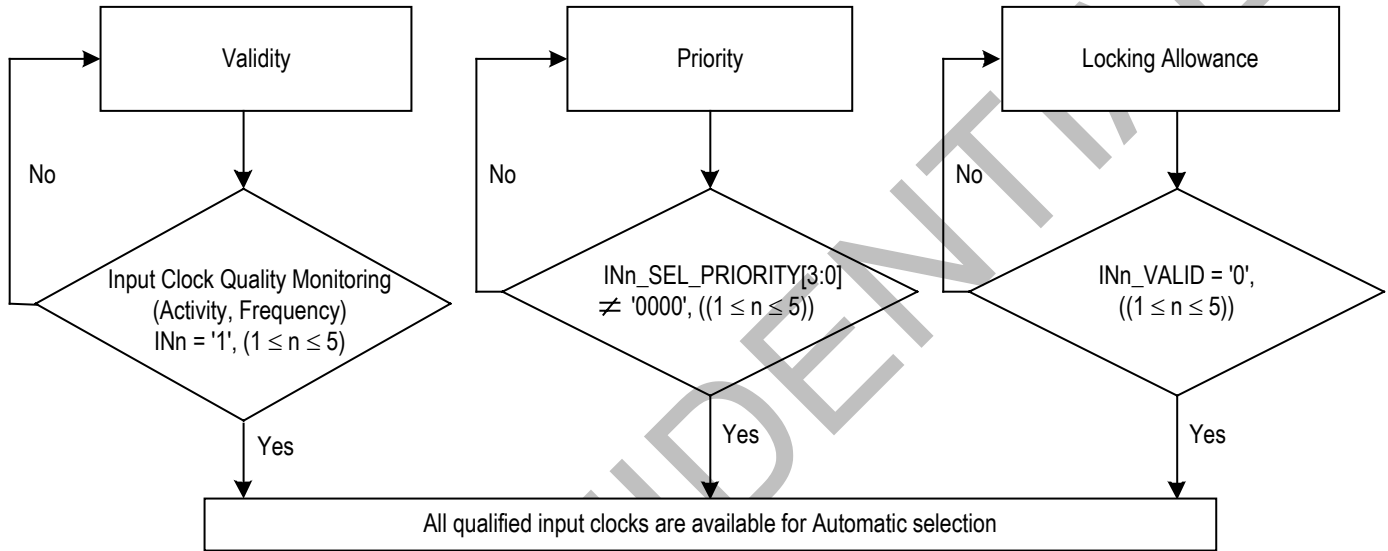

Figure 6. Qualified Input Clocks for Automatic Selection

Table 9: Related Bit / Register in Chapter 3.6

Bit	Register	Address (Hex)
EXT_SW	MON_SW_PBO_CNFG	0B
T0_INPUT_SEL[3:0]	T0_INPUT_SEL_CNFG	50
T4_LOCK_T0	T4_INPUT_SEL_CNFG	51
T0_FOR_T4		
T4_INPUT_SEL[3:0]		
INn_SEL_PRIORITY[3:0] (1 ≤ n ≤ 5)	IN1_IN2_SEL_PRIORITY_CNFG IN3_IN4_SEL_PRIORITY_CNFG IN5_SEL_PRIORITY_CNFG	27 ~ 28, 2B
INn_VALID (1 ≤ n ≤ 5)	REMOTE_INPUT_VALID1_CNFG, REMOTE_INPUT_VALID2_CNFG	4C, 4D
INn (1 ≤ n ≤ 5)	INPUT_VALID1_STS, INPUT_VALID2_STS	4A, 4B
T4_T0_SEL	T4_T0_REG_SEL_CNFG	07

Note: * The setting in the 26 ~ 2C registers is either for T0 path or for T4 path, as determined by the T4_T0_SEL bit.

3.7 SELECTED INPUT CLOCK MONITORING

The quality of the selected input clock is always monitored (refer to [Chapter 3.5 Input Clock Quality Monitoring](#)) and the DPLL locking status is always monitored.

3.7.1 T0 / T4 DPLL LOCKING DETECTION

The following events are always monitored:

- Fast Loss;
- Coarse Phase Loss;
- Fine Phase Loss;
- Hard Limit Exceeding.

3.7.1.1 Fast Loss

A fast loss is triggered when the selected input clock misses 2 consecutive clock cycles. It is cleared once an active clock edge is detected.

For T0 path, the occurrence of the fast loss will result in T0 DPLL being unlocked if the FAST_LOS_SW bit is '1'. For T4 path, the occurrence of the fast loss will result in T4 DPLL being unlocked regardless of the FAST_LOS_SW bit.

3.7.1.2 Coarse Phase Loss

The T0/T4 DPLL compares the selected input clock with the feedback signal. If the phase-compared result exceeds the coarse phase limit, a coarse phase loss is triggered. It is cleared once the phase-compared result is within the coarse phase limit.

When the selected input clock is of 2 kHz, 4 kHz or 8 kHz, the coarse phase limit depends on the MULTI_PH_8K_4K_2K_EN bit, the WIDE_EN bit and the PH_LOS_COARSE_LIMT[3:0] bits. Refer to [Table 10](#). When the selected input clock is of other frequencies than 2 kHz, 4 kHz and 8 kHz, the coarse phase limit depends on the WIDE_EN bit and the PH_LOS_COARSE_LIMT[3:0] bits. Refer to [Table 11](#).

Table 10: Coarse Phase Limit Programming (the selected input clock of 2 kHz, 4 kHz or 8 kHz)

MULTI_PH_8K_4K_2K_EN	WIDE_EN	Coarse Phase Limit
0	don't-care	±1 UI
1	0	±1 UI
	1	set by the PH_LOS_COARSE_LIMT[3:0] bits

Table 11: Coarse Phase Limit Programming (the selected input clock of other than 2 kHz, 4 kHz and 8 kHz)

WIDE_EN	Coarse Phase Limit
0	±1 UI
1	set by the PH_LOS_COARSE_LIMT[3:0] bits

The occurrence of the coarse phase loss will result in T0/T4 DPLL being unlocked if the COARSE_PH_LOS_LIMT_EN bit is '1'.

3.7.1.3 Fine Phase Loss

The T0/T4 DPLL compares the selected input clock with the feedback signal. If the phase-compared result exceeds the fine phase limit programmed by the PH_LOS_FINE_LIMT[2:0] bits, a fine phase loss is triggered. It is cleared once the phase-compared result is within the fine phase limit.

The occurrence of the fine phase loss will result in T0/T4 DPLL being unlocked if the FINE_PH_LOS_LIMT_EN bit is '1'.

3.7.1.4 Hard Limit Exceeding

Two limits are available for this monitoring. They are DPLL soft limit and DPLL hard limit. When the frequency of the DPLL output with respect to the master clock exceeds the DPLL soft / hard limit, a DPLL soft / hard alarm will be raised; the alarm is cleared once the frequency is within the corresponding limit. The occurrence of the DPLL soft alarm does not affect the T0/T4 DPLL locking status. The DPLL soft alarm is indicated by the corresponding T0_DPLL_SOFT_FREQ_ALARM / T4_DPLL_SOFT_FREQ_ALARM bit. The occurrence of the DPLL hard alarm will result in T0/T4 DPLL being unlocked if the FREQ_LIMT_PH_LOS bit is '1'.

The DPLL soft limit is set by the DPLL_FREQ_SOFT_LIMT[6:0] bits and can be calculated as follows:

$$DPLL \text{ Soft Limit (ppm)} = DPLL_FREQ_SOFT_LIMT[6:0] \times 0.724$$

The DPLL hard limit is set by the DPLL_FREQ_HARD_LIMT[15:0] bits and can be calculated as follows:

$$DPLL \text{ Hard Limit (ppm)} = DPLL_FREQ_HARD_LIMT[15:0] \times 0.0014$$

3.7.2 LOCKING STATUS

The DPLL locking status depends on the locking monitoring results. The DPLL is in locked state if none of the following events is triggered during 2 seconds; otherwise, the DPLL is unlocked.

- Fast Loss (the FAST_LOS_SW bit is '1');
- Coarse Phase Loss (the COARSE_PH_LOS_LIMT_EN bit is '1');
- Fine Phase Loss (the FINE_PH_LOS_LIMT_EN bit is '1');
- DPLL Hard Alarm (the FREQ_LIMT_PH_LOS bit is '1').

If the FAST_LOS_SW bit, the COARSE_PH_LOS_LIMT_EN bit, the FINE_PH_LOS_LIMT_EN bit or the FREQ_LIMT_PH_LOS bit is '0', the DPLL locking status will not be affected even if the corresponding event is triggered. If all these bits are '0', the DPLL will be in locked state in 2 seconds.

The DPLL locking status is indicated by the T0_DPLL_LOCK / T4_DPLL_LOCK bit.

The T4_STS¹ bit will be set when the locking status of the T4 DPLL changes (from 'locked' to 'unlocked' or from 'unlocked' to 'locked'). If the T4_STS² bit is '1', an interrupt will be generated.

3.7.3 PHASE LOCK ALARM (T0 ONLY)

A phase lock alarm will be raised when the selected input clock can not be locked in T0 DPLL within a certain period. This period can be calculated as follows:

$$Period (sec.) = TIME_OUT_VALUE[5:0] \times MULTI_FACTOR[1:0]$$

The phase lock alarm is indicated by the corresponding INn_PH_LOCK_ALARM bit (1 ≤ n ≤ 5).

The phase lock alarm can be cleared by the following two ways, as selected by the PH_ALARM_TIMEOUT bit:

- Be cleared when a '1' is written to the corresponding INn_PH_LOCK_ALARM bit;
- Be cleared after the period (= $TIME_OUT_VALUE[5:0] \times MULTI_FACTOR[1:0]$ in seconds) which starts from when the alarm is raised.

The selected input clock with a phase lock alarm is disqualified for T0 DPLL locking.

Note that no phase lock alarm is raised if the T4 selected input clock can not be locked.

Table 12: Related Bit / Register in Chapter 3.7

Bit	Register	Address (Hex)
FAST_LOS_SW	PHASE_LOSS_FINE_LIMIT_CNFG	5B *
PH_LOS_FINE_LIMIT[2:0]		
FINE_PH_LOS_LIMIT_EN		
MULTI_PH_8K_4K_2K_EN	PHASE_LOSS_COARSE_LIMIT_CNFG	5A *
WIDE_EN		
PH_LOS_COARSE_LIMIT[3:0]		
COARSE_PH_LOS_LIMIT_EN	OPERATING_STS	52
T0_DPLL_SOFT_FREQ_ALARM		
T4_DPLL_SOFT_FREQ_ALARM		
T0_DPLL_LOCK		
T4_DPLL_LOCK	DPLL_FREQ_SOFT_LIMIT_CNFG	65
DPLL_FREQ_SOFT_LIMIT[6:0]		
FREQ_LIMIT_PH_LOS	DPLL_FREQ_HARD_LIMIT[15:8]_CNFG, DPLL_FREQ_HARD_LIMIT[7:0]_CNFG	67, 66
DPLL_FREQ_HARD_LIMIT[15:0]		
T4_STS ¹	INTERRUPTS3_STS	0F
T4_STS ²	INTERRUPTS3_ENABLE_CNFG	12
TIME_OUT_VALUE[5:0]	PHASE_ALARM_TIME_OUT_CNFG	08
MULTI_FACTOR[1:0]		
INn_PH_LOCK_ALARM (1 ≤ n ≤ 5)	IN1_IN2_STS, IN3_IN4_STS, IN5_STS	44 ~ 45, 48
PH_ALARM_TIMEOUT	INPUT_MODE_CNFG	09
T4_T0_SEL	T4_T0_REG_SEL_CNFG	07

Note: * The setting in the 5A and 5B registers is either for T0 path or for T4 path, as determined by the T4_T0_SEL bit.

3.8 INPUT CLOCK SELECTION

If the input clock is selected by External Fast selection or by Forced selection, it can be switched by setting the related registers (refer to [Chapter 3.6.1 External Fast Selection \(T0 only\)](#) & [Chapter 3.6.2 Forced Selection](#)) any time. In this case, whether the input clock is qualified for DPLL locking does not affect the clock switch. If the T4 selected input clock is a T0 DPLL output, it can only be switched by setting the T0_FOR_T4 bit.

When the input clock is selected by Automatic selection, the input clock switch depends on its validity, priority and locking allowance configuration. If the current selected input clock is disqualified, a new qualified input clock may be switched to.

3.8.1 INPUT CLOCK VALIDITY

For all the input clocks, the validity depends on the results of input clock quality monitoring (refer to [Chapter 3.5 Input Clock Quality Monitoring](#)). When all of the following conditions are satisfied, the input clock is valid; otherwise, it is invalid.

- No no-activity alarm (the INn_NO_ACTIVITY_ALARM bit is '0');
- No frequency hard alarm (the INn_FREQ_HARD_ALARM bit is '0');
- If the IN_NOISE_WINDOW bit is '1', all the edges of the input clock of 2 kHz, 4 kHz or 8 kHz drift inside $\pm 5\%$; if the IN_NOISE_WINDOW bit is '0', this condition is ignored.

The validity qualification of the T0 selected input clock is different from that of the T4 selected input clock. The validity qualification of the T4 selected input clock is the same as the above. The T0 selected input clock is valid when all of the above and the following conditions are satisfied; otherwise, it is invalid.

- No phase lock alarm, i.e., the INn_PH_LOCK_ALARM bit is '0';
- If the ULTR_FAST_SW bit is '1', the T0 selected input clock misses less than (<) 2 consecutive clock cycles; if the ULTR_FAST_SW bit is '0', this condition is ignored.

The validities of all the input clocks are indicated by the INn¹ bit (1 ≤ n ≤ 5). When the input clock validity changes (from 'valid' to 'invalid' or from 'invalid' to 'valid'), the INn² bit will be set. If the INn³ bit is '1', an interrupt will be generated.

When the T0 selected input clock has failed, i.e., the validity of the T0 selected input clock changes from 'valid' to 'invalid', the T0_MAIN_REF_FAILED¹ bit will be set. If the T0_MAIN_REF_FAILED² bit is '1', an interrupt will be generated. This interrupt can also be indicated by hardware - the TDO pin, as determined by the LOS_FLAG_TO_TDO bit. When the TDO pin is used to indicate this interrupt, it will be set high when this interrupt is generated and will remain high until this interrupt is cleared.

3.8.2 SELECTED INPUT CLOCK SWITCH

When the device is configured as Automatic input clock selection, T0 input clock switch is different from T4 input clock switch.

For T0 path, Revertive and Non-Revertive switches are supported, as selected by the REVERTIVE_MODE bit.

For T4 path, only Revertive switch is supported.

GR-1244 defines Revertive and Non-Revertive Reference switching. In Non-Revertive switching, a switch to an alternate reference is maintained even after the original reference has recovered from the failure that caused the switch. In Revertive switching, the clock switches back to the original reference after that reference recovers from the failure, independent of the condition of the alternate reference. In Non-Revertive switching, input clock switch is minimized

Conditions of the qualified input clocks available for T0 selection are different from that for T4 selection, as shown in [Table 13](#):

Table 13: Conditions of Qualified Input Clocks Available for T0 & T4 Selection

Conditions of Qualified Input Clocks Available for T0 & T4 Selection	
T0	<ul style="list-style-type: none"> • Valid, i.e., the INn¹ bit is '1'; • Priority enabled, i.e., the corresponding INn_SEL_PRIORITY[3:0] bits are not '0000'; • Locking to the input clock is allowed, i.e., the corresponding INn_VALID bit is '0'.
T4	<ul style="list-style-type: none"> • Valid (all the validity conditions listed in Chapter 3.8.1 Input Clock Validity are satisfied); • Priority enabled, i.e., the corresponding INn_SEL_PRIORITY[3:0] bits are not '0000'; • Locking to the input clock is allowed, i.e., the corresponding INn_VALID bit is '0'.

The input clock is disqualified if any of the above conditions is not satisfied.

In summary, the selected input clock can be switched by:

- External Fast selection (supported by T0 path only);
- Forced selection;
- Revertive switch;
- Non-Revertive switch (supported by T0 path only);
- T4 DPLL locked to T0 DPLL output (supported by T4 path only).

3.8.2.1 Revertive Switch

In Revertive switch, the selected input clock is switched when another qualified input clock with a higher priority than the current selected input clock is available.

The selected input clock is switched if any of the following is satisfied:

- the selected input clock is disqualified;
- another qualified input clock with a higher priority than the selected input clock is available.

A qualified input clock with the highest priority is selected by revertive switch. If more than one qualified input clock INn is available and has the same priority, the input clock with the smallest 'n' is selected.

3.8.2.2 Non-Revertive Switch (T0 only)

In Non-Revertive switch, the T0 selected input clock is not switched when another qualified input clock with a higher priority than the current selected input clock is available. In this case, the selected input clock is switched and a qualified input clock with the highest priority is selected only when the T0 selected input clock is disqualified. If more than one qualified input clock is available and has the same priority, the input clock with the smallest 'n' is selected.

3.8.3 SELECTED / QUALIFIED INPUT CLOCKS INDICATION

The selected input clock is indicated by the CURRENTLY_SELECTED_INPUT[3:0] bits. Note if the T4 selected input clock is a T0 DPLL output, it can not be indicated by these bits.

The qualified input clocks with the three highest priorities are indicated by HIGHEST_PRIORITY_VALIDATED[3:0] bits, the SECOND_PRIORITY_VALIDATED[3:0] bits and the THIRD_PRIORITY_VALIDATED[3:0] bits respectively. If more than one input clock INn has the same priority, the input clock with the smallest 'n' is indicated by the HIGHEST_PRIORITY_VALIDATED[3:0] bits.

When the device is configured in Automatic selection and Revertive switch is enabled, the input clock indicated by the CURRENTLY_SELECTED_INPUT[3:0] bits is the same as the one indicated by the HIGHEST_PRIORITY_VALIDATED[3:0] bits.

When all the input clocks for T4 path become unqualified, the INPUT_TO_T4¹ bit will be set. If the INPUT_TO_T4² bit is '1', an interrupt will be generated.

Table 14: Related Bit / Register in Chapter 3.8

Bit	Register	Address (Hex)
T0_FOR_T4	T4_INPUT_SEL_CNFG	51
INn ¹ (1 ≤ n ≤ 5)	INPUT_VALID1_STS, INPUT_VALID2_STS	4A, 4B
INn ² (1 ≤ n ≤ 5)	INTERRUPTS1_STS, INTERRUPTS2_STS	0D, 0E
INn ³ (1 ≤ n ≤ 5)	INTERRUPTS1_ENABLE_CNFG, INTERRUPTS2_ENABLE_CNFG	10, 11
INn_NO_ACTIVITY_ALARM (1 ≤ n ≤ 5)	IN1_IN2_STS, IN3_IN4_STS, IN5_STS	44 ~ 45, 48
INn_FREQ_HARD_ALARM (1 ≤ n ≤ 5)		
INn_PH_LOCK_ALARM (1 ≤ n ≤ 5)		
IN_NOISE_WINDOW	PHASE_MON_PBO_CNFG	78
ULTR_FAST_SW	MON_SW_PBO_CNFG	0B
LOS_FLAG_TO_TDO		
T0_MAIN_REF_FAILED ¹	INTERRUPTS2_STS	0E
T0_MAIN_REF_FAILED ²	INTERRUPTS2_ENABLE_CNFG	11
INPUT_TO_T4 ¹	INTERRUPTS3_STS	0F
INPUT_TO_T4 ²	INTERRUPTS3_ENABLE_CNFG	12
REVERTIVE_MODE	INPUT_MODE_CNFG	09
INn_SEL_PRIORITY[3:0] (1 ≤ n ≤ 5)	IN1_IN2_SEL_PRIORITY_CNFG, IN3_IN4_SEL_PRIORITY_CNFG, IN5_SEL_PRIORITY_CNFG	27 ~ 28, 2B
INn_VALID (1 ≤ n ≤ 5)	REMOTE_INPUT_VALID1_CNFG, REMOTE_INPUT_VALID2_CNFG	4C, 4D
CURRENTLY_SELECTED_INPUT[3:0]	PRIORITY_TABLE1_STS	4E *
HIGHEST_PRIORITY_VALIDATED[3:0]		
SECOND_PRIORITY_VALIDATED[3:0]		
THIRD_PRIORITY_VALIDATED[3:0]	PRIORITY_TABLE2_STS	4F *
T4_T0_SEL	T4_T0_REG_SEL_CNFG	07

Note: * The setting in the 26 ~ 2C, 4E and 4F registers is either for T0 path or for T4 path, as determined by the T4_T0_SEL bit.

3.9 SELECTED INPUT CLOCK STATUS VS. DPLL OPERATING MODE

The operating modes supported by T0 DPLL are more complex than the ones supported by T4 DPLL. T0 DPLL supports three primary operating modes: Free-Run, Locked and Holdover, and three secondary, temporary operating modes: Pre-Locked, Pre-Locked2 and Lost-Phase. T4 DPLL supports three operating modes: Free-Run, Locked and Hold-over. The operating modes of T0 DPLL and T4 DPLL can be switched automatically or by force, as controlled by the T0_OPERATING_MODE[2:0] / T4_OPERATING_MODE[2:0] bits respectively.

When the operating mode is switched by force, the operating mode switch is under external control and the status of the selected input clock takes no effect to the operating mode selection.

When the operating mode is switched automatically, the internal state machines for T0 and for T4 automatically determine the operating mode respectively.

3.9.1 T0 SELECTED INPUT CLOCK VS. DPLL OPERATING MODE

The T0 DPLL operating mode is controlled by the T0_OPERATING_MODE[2:0] bits, as shown in Table 15:

Table 15: T0 DPLL Operating Mode Control

T0_OPERATING_MODE[2:0]	T0 DPLL Operating Mode
000	Automatic
001	Forced - Free-Run
010	Forced - Holdover
100	Forced - Locked
101	Forced - Pre-Locked2
110	Forced - Pre-Locked
111	Forced - Lost-Phase

When the operating mode is switched automatically, the operation of the internal state machine is shown in Figure 7.

Whether the operating mode is under external control or is switched automatically, the current operating mode is always indicated by the T0_DPLL_OPERATING_MODE[2:0] bits. When the operating mode switches, the T0_OPERATING_MODE¹ bit will be set. If the T0_OPERATING_MODE² bit is '1', an interrupt will be generated.

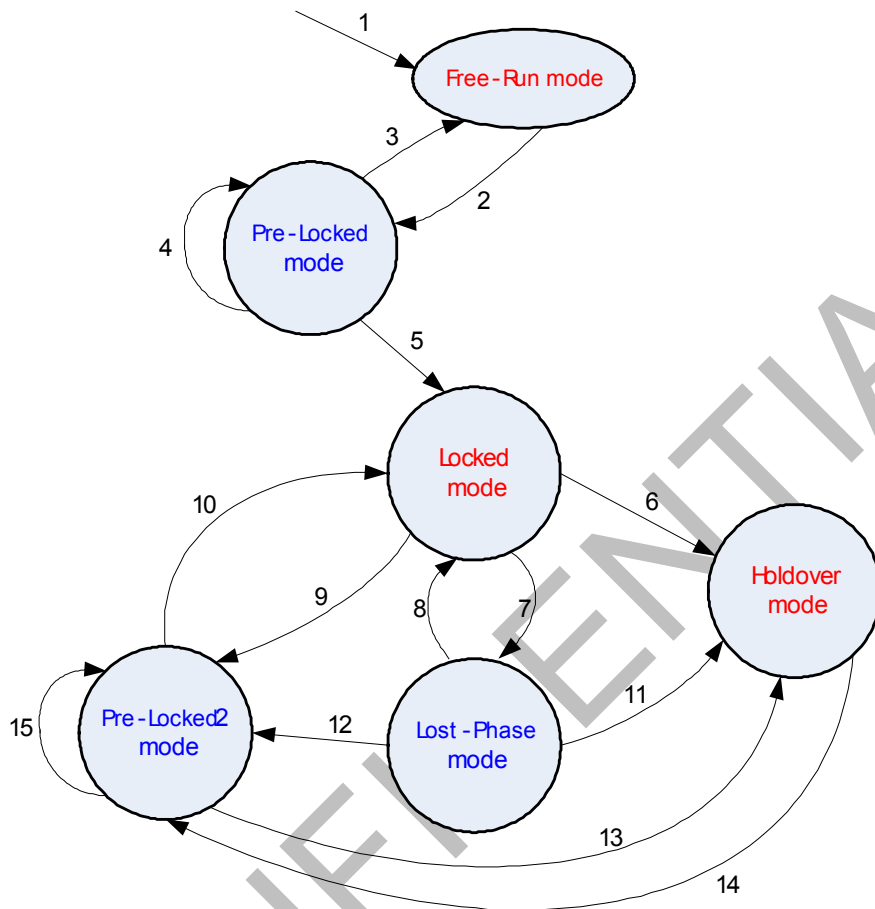

Figure 7. T0 Selected Input Clock vs. DPLL Automatic Operating Mode

Notes to Figure 7:

1. Reset.
2. An input clock is selected.
3. The T0 selected input clock is disqualified **AND** No qualified input clock is available.
4. The T0 selected input clock is switched to another one.
5. The T0 selected input clock is locked (the T0_DPLL_LOCK bit is '1').
6. The T0 selected input clock is disqualified **AND** No qualified input clock is available.
7. The T0 selected input clock is unlocked (the T0_DPLL_LOCK bit is '0').
8. The T0 selected input clock is locked again (the T0_DPLL_LOCK bit is '1').
9. The T0 selected input clock is switched to another one.
10. The T0 selected input clock is locked (the T0_DPLL_LOCK bit is '1').
11. The T0 selected input clock is disqualified **AND** No qualified input clock is available.
12. The T0 selected input clock is switched to another one.
13. The T0 selected input clock is disqualified **AND** No qualified input clock is available.
14. An input clock is selected.
15. The T0 selected input clock is switched to another one.

The causes of Item 4, 9, 12, 15 - 'the T0 selected input clock is switched to another one' - are: (The T0 selected input clock is disqualified **AND** Another input clock is switched to) **OR** (In Revertive switch, a qualified input clock with a higher priority is switched to) **OR** (The T0 selected input clock is switched to another one by External Fast selection or Forced selection).

Refer to Table 13 for details about the input clock qualification for T0 path.

3.9.2 T4 SELECTED INPUT CLOCK VS. DPLL OPERATING MODE

The T4 DPLL operating mode is controlled by the T4_OPERATING_MODE[2:0] bits, as shown in Table 16:

Table 16: T4 DPLL Operating Mode Control

T4_OPERATING_MODE[2:0]	T4 DPLL Operating Mode
000	Automatic
001	Forced - Free-Run
010	Forced - Holdover
100	Forced - Locked

When the operating mode is switched automatically, the operation of the internal state machine is shown in Figure 8:

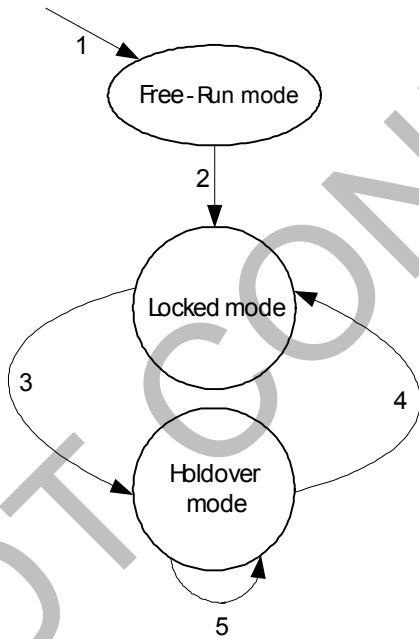

Figure 8. T4 Selected Input Clock vs. DPLL Automatic Operating Mode

Notes to Figure 8:

1. Reset.
2. An input clock is selected.
3. (The T4 selected input clock is disqualified) **OR** (A qualified input clock with a higher priority is switched to) **OR** (The T4 selected input clock is switched to another one by Forced selection) **OR** (When T4 DPLL locks to the T0 DPLL output, the T4 selected input clock is switched by setting the T0_FOR_T4 bit).
4. An input clock is selected.
5. No input clock is selected.

Refer to Table 13 for details about the input clock qualification for T4 path.

Table 17: Related Bit / Register in Chapter 3.9

Bit	Register	Address (Hex)
T0_OPERATING_MODE[2:0]	T0_OPERATING_MODE_CNFG	53
T4_OPERATING_MODE[2:0]	T4_OPERATING_MODE_CNFG	54
T0_DPLL_OPERATING_MODE[2:0]	OPERATING_STS	52
T0_DPLL_LOCK		
T0_OPERATING_MODE ¹	INTERRUPTS2_STS	0E
T0_OPERATING_MODE ²	INTERRUPTS2_ENABLE_CNFG	11
T0_FOR_T4	T4_INPUT_SEL_CNFG	51

3.10 T0 / T4 DPLL OPERATING MODE

The T0/T4 DPLL gives a stable performance in different applications without being affected by operating conditions or silicon process variations. It integrates a PFD (Phase & Frequency Detector), a LPF (Low Pass Filter) and a DCO (Digital Controlled Oscillator), which form a closed loop. If no input clock is selected, the loop is not closed, and the PFD and LPF do not function.

The PFD detects the phase error, including the fast loss, coarse phase loss and fine phase loss (refer to [Chapter 3.7.1.1 Fast Loss](#) to [Chapter 3.7.1.3 Fine Phase Loss](#)). The averaged phase error of the T0/T4 DPLL feedback with respect to the selected input clock is indicated by the CURRENT_PH_DATA[15:0] bits. It can be calculated as follows:

$$\text{Averaged Phase Error (ns)} = \text{CURRENT_PH_DATA}[15:0] \times 0.61$$

The LPF filters jitters. Its 3 dB bandwidth and damping factor are programmable. A range of bandwidths and damping factors can be set to meet different application requirements. Generally, the lower the damping factor is, the longer the locking time is and the more the gain is.

The DCO controls the DPLL output. The frequency of the DPLL output is always multiplied on the basis of the master clock. The phase and frequency offset of the DPLL output may be locked to those of the selected input clock. The current frequency offset with respect to the master clock is indicated by the CURRENT_DPLL_FREQ[23:0] bits, and can be calculated as follows:

$$\text{Current Frequency Offset (ppm)} = \text{CURRENT_DPLL_FREQ}[23:0] \times 0.000011$$

3.10.1 T0 DPLL OPERATING MODE

The T0 DPLL loop is closed except in Free-Run mode and Holdover mode.

For a closed loop, different bandwidths and damping factors can be used depending on DPLL locking stages: starting, acquisition and locked.

In the first two seconds when the T0 DPLL attempts to lock to the selected input clock, the starting bandwidth and damping factor are used. They are set by the T0_DPLL_START_BW[4:0] bits and the T0_DPLL_START_DAMPING[2:0] bits respectively.

During the acquisition, the acquisition bandwidth and damping factor are used. They are set by the T0_DPLL_ACQ_BW[4:0] bits and the T0_DPLL_ACQ_DAMPING[2:0] bits respectively.

When the T0 selected input clock is locked, the locked bandwidth and damping factor are used. They are set by the T0_DPLL_LOCKED_BW[4:0] bits and the T0_DPLL_LOCKED_DAMPING[2:0] bits respectively.

The corresponding bandwidth and damping factor are used when the T0 DPLL operates in different DPLL locking stages: starting, acquisition and locked, as controlled by the device automatically.

Only the locked bandwidth and damping factor can be used regardless of the T0 DPLL locking stage, as controlled by the AUTO_BW_SEL bit.

3.10.1.1 Free-Run Mode

In Free-Run mode, the T0 DPLL output refers to the master clock and is not affected by any input clock. The accuracy of the T0 DPLL output is equal to that of the master clock.

3.10.1.2 Pre-Locked Mode

In Pre-Locked mode, the T0 DPLL output attempts to track the selected input clock.

The Pre-Locked mode is a secondary, temporary mode.

3.10.1.3 Locked Mode

In Locked mode, the T0 selected input clock is locked. The phase and frequency offset of the T0 DPLL output track those of the T0 selected input clock.

In this mode, if the T0 selected input clock is in fast loss status and the FAST_LOS_SW bit is '1', the T0 DPLL is unlocked (refer to [Chapter 3.7.1.1 Fast Loss](#)) and will enter Lost-Phase mode when the operating mode is switched automatically; if the T0 selected input clock is in fast loss status and the FAST_LOS_SW bit is '0', the T0 DPLL locking status is not affected and the T0 DPLL will enter Temp-Holdover mode automatically.

3.10.1.3.1 Temp-Holdover Mode

The T0 DPLL will automatically enter Temp-Holdover mode with a selected input clock switch or no qualified input clock available when the operating mode switch is under external control.

In Temp-Holdover mode, the T0 DPLL has temporarily lost the selected input clock. The T0 DPLL operation in Temp-Holdover mode and that in Holdover mode are alike (refer to [Chapter 3.10.1.5 Holdover Mode](#)) except the frequency offset acquiring methods. See [Chapter 3.10.1.5 Holdover Mode](#) for details about the methods. The method is selected by the TEMP_HOLDOVER_MODE[1:0] bits, as shown in [Table 18](#):

Table 18: Frequency Offset Control in Temp-Holdover Mode

TEMP_HOLDOVER_MODE[1:0]	Frequency Offset Acquiring Method
00	the same as that used in Holdover mode
01	Automatic Instantaneous
10	Automatic Fast Averaged
11	Automatic Slow Averaged

The device automatically controls the T0 DPLL to exit from Temp-Holdover mode.

3.10.1.4 Lost-Phase Mode

In Lost-Phase mode, the T0 DPLL output attempts to track the selected input clock.

The Lost-Phase mode is a secondary, temporary mode.

3.10.1.5 Holdover Mode

In Holdover mode, the T0 DPLL resorts to the stored frequency data acquired in Locked mode to control its output. The T0 DPLL output is not

phase locked to any input clock. The frequency offset acquiring method is selected by the MAN_HOLDOVER bit, the AUTO_AVG bit and the FAST_AVG bit, as shown in [Table 19](#):

Table 19: Frequency Offset Control in Holdover Mode

MAN_HOLDOVER	AUTO_AVG	FAST_AVG	Frequency Offset Acquiring Method
0	0	don't-care	Automatic Instantaneous
	1	0	Automatic Slow Averaged
		1	Automatic Fast Averaged
1	don't-care		Manual

3.10.1.5.1 Automatic Instantaneous

By this method, the T0 DPLL freezes at the operating frequency when it enters Holdover mode. The accuracy is 4.4×10^{-8} ppm.

3.10.1.5.2 Automatic Slow Averaged

By this method, an internal IIR (Infinite Impulse Response) filter is employed to get the frequency offset. The IIR filter gives a 3 dB attenuation point corresponding to a period of 110 minutes. The accuracy is 1.1×10^{-5} ppm.

3.10.1.5.3 Automatic Fast Averaged

By this method, an internal IIR (Infinite Impulse Response) filter is employed to get the frequency offset. The IIR filter gives a 3 dB attenuation point corresponding to a period of 8 minutes. The accuracy is 1.1×10^{-5} ppm.

3.10.1.5.4 Manual

By this method, the frequency offset is set by the T0_HOLDOVER_FREQ[23:0] bits. The accuracy is 1.1×10^{-5} ppm.

The frequency offset of the T0 DPLL output is indicated by the CURRENT_DPLL_FREQ[23:0] bits.

The device provides a reference for the value to be written to the T0_HOLDOVER_FREQ[23:0] bits. The value to be written can refer to the value read from the CURRENT_DPLL_FREQ[23:0] bits or the T0_HOLDOVER_FREQ[23:0] bits (refer to [Chapter 3.10.1.5.5 Holdover Frequency Offset Read](#)); or then be processed by external software filtering.

3.10.1.5.5 Holdover Frequency Offset Read

The offset value, which is acquired by Automatic Slow Averaged, Automatic Fast Averaged and is set by related register bits, can be read from the T0_HOLDOVER_FREQ[23:0] bits by setting the READ_AVG bit and the FAST_AVG bit, as shown in [Table 20](#).

Table 20: Holdover Frequency Offset Read

READ_AVG	FAST_AVG	Offset Value Read from T0_HOLDOVER_FREQ[23:0]
0	don't-care	The value is equal to the one written to.
1	0	The value is acquired by Automatic Slow Averaged method, not equal to the one written to.
	1	The value is acquired by Automatic Fast Averaged method, not equal to the one written to.

The frequency offset in ppm is calculated as follows:

$$\text{Holdover Frequency Offset (ppm)} = T0_HOLDOVER_FREQ[23:0] \times 0.000011$$

3.10.1.6 Pre-Locked2 Mode

In Pre-Locked2 mode, the T0 DPLL output attempts to track the selected input clock.

The Pre-Locked2 mode is a secondary, temporary mode.

3.10.2 T4 DPLL OPERATING MODE

The T4 path is simpler compared with the T0 path.

3.10.2.1 Free-Run Mode

In Free-Run mode, the T4 DPLL output refers to the master clock and is affected by any input clock. The accuracy of the T4 DPLL output is equal to that of the master clock.

3.10.2.2 Locked Mode

In Locked mode, the T4 selected input clock may be locked in the T4 DPLL.

When the T4 selected input clock is locked, the phase and frequency offset of the T4 DPLL output track those of the T4 selected input clock; when unlocked, the phase and frequency offset of the T4 DPLL output attempt to track those of the selected input clock.

The T4 DPLL loop is closed in Locked mode. Its bandwidth and damping factor are set by the T4_DPLL_LOCKED_BW[1:0] bits and the T4_DPLL_LOCKED_DAMPING[2:0] bits respectively.

3.10.2.3 Holdover Mode

In Holdover mode, the T4 DPLL resorts to the stored frequency data acquired in Locked mode to control its output. The T4 DPLL output is not

phase locked to any input clock. The T4 DPLL freezes at the operating frequency when it enters Holdover mode. The accuracy is 4.4×10^{-8} ppm.

Table 21: Related Bit / Register in Chapter 3.10

Bit	Register	Address (Hex)
CURRENT_PH_DATA[15:0]	CURRENT_DPLL_PHASE[15:8]_STS, CURRENT_DPLL_PHASE[7:0]_STS	69 *, 68 *
CURRENT_DPLL_FREQ[23:0]	CURRENT_DPLL_FREQ[23:16]_STS, CURRENT_DPLL_FREQ[15:8]_STS, CURRENT_DPLL_FREQ[7:0]_STS	64 *, 63 *, 62 *
T0_DPLL_START_BW[4:0]	T0_DPLL_START_BW_DAMPING_CNFG	56
T0_DPLL_START_DAMPING[2:0]		
T0_DPLL_ACQ_BW[4:0]	T0_DPLL_ACQ_BW_DAMPING_CNFG	57
T0_DPLL_ACQ_DAMPING[2:0]		
T0_DPLL_LOCKED_BW[4:0]	T0_DPLL_LOCKED_BW_DAMPING_CNFG	58
T0_DPLL_LOCKED_DAMPING[2:0]		
AUTO_BW_SEL	T0_BW_OVERSHOOT_CNFG	59
FAST_LOS_SW	PHASE_LOSS_FINE_LIMIT_CNFG	5B *
TEMP_HOLDOVER_MODE[1:0]	T0_HOLDOVER_MODE_CNFG	5C
MAN_HOLDOVER		
AUTO_AVG		
FAST_AVG		
READ_AVG		
T0_HOLDOVER_FREQ[23:0]	T0_HOLDOVER_FREQ[23:16]_CNFG, T0_HOLDOVER_FREQ[15:8]_CNFG, T0_HOLDOVER_FREQ[7:0]_CNFG	5F, 5E, 5D
T4_DPLL_LOCKED_BW[1:0]	T4_DPLL_LOCKED_BW_DAMPING_CNFG	61
T4_DPLL_LOCKED_DAMPING[2:0]		
T4_T0_SEL	T4_T0_REG_SEL_CNFG	07

Note: * The setting in the 5B, 62 ~ 64, 68 and 69 registers is either for T0 path or for T4 path, as determined by the T4_T0_SEL bit.

3.11 T0 / T4 DPLL OUTPUT

The DPLL output is locked to the selected input clock. According to the phase-compared result of the feedback and the selected input clock, and the DPLL output frequency offset, the PFD output is limited and the DPLL output is frequency offset limited.

3.11.1 PFD OUTPUT LIMIT

The PFD output is limited to be within ± 1 UI or within the coarse phase limit (refer to [Chapter 3.7.1.2 Coarse Phase Loss](#)), as determined by the MULTI_PH_APP bit.

3.11.2 FREQUENCY OFFSET LIMIT

The DPLL output is limited to be within the DPLL hard limit (refer to [Chapter 3.7.1.4 Hard Limit Exceeding](#)).

For T0 DPLL, the integral path value can be frozen when the DPLL hard limit is reached. This function, enabled by the T0_LIMT bit, will minimize the subsequent overshoot when T0 DPLL is pulling in.

3.11.3 PBO (T0 ONLY)

The PBO function is only supported by the T0 path.

When a PBO event is triggered, the phase offset of the selected input clock with respect to the T0 DPLL output is measured. The device then automatically accounts for the measured phase offset and compensates an appropriate phase offset into the DPLL output so that the phase transients on the T0 DPLL output are minimized.

A PBO event is triggered if any one of the following conditions occurs:

- T0 selected input clock switches (the PBO_EN bit is '1');
- T0 DPLL exits from Holdover mode or Free-Run mode (the PBO_EN bit is '1');
- Phase changes on the T0 selected input clock are greater than a programmable limit over an interval of less than 0.1 seconds (the PH_MON_PBO_EN bit is '1').

For the first two conditions, the phase transients on the T0 DPLL output are minimized to be no more than 0.61 ns with PBO. The PBO can also be frozen at the current phase offset by setting the PBO_FREZ bit. When the PBO is frozen, the device will ignore any further PBO events triggered by the above two conditions, and maintain the current phase offset. When the PBO is disabled, there may be a phase shift on the T0 DPLL output and the T0 DPLL output tracks back to 0 degree phase offset with respect to the T0 selected input clock.

Phase changes of more than 1.0 μ s but less than 3.5 μ s that occur over an interval of less than 0.1 seconds may or may not be built-out.

An integrated Phase Transient Monitor can be enabled by the PH_MON_EN bit to monitor the phase changes on the T0 selected input

clock. When the phase changes are greater than a limit over an interval of less than 0.1 seconds, a PBO event is triggered and the phase transients on the DPLL output are absorbed. The limit is programmed by the PH_TR_MON_LIMT[3:0] bits, and can be calculated as follows:

$$\text{Limit (ns)} = (\text{PH_TR_MON_LIMT}[3:0] + 7) \times 156$$

The phase offset induced by PBO will never result in a coarse or fine phase loss.

3.11.4 PHASE OFFSET SELECTION (T0 ONLY)

The phase offset of the T0 selected input clock with respect to the T0 DPLL output can be adjusted. If the device is configured as the Master, the PH_OFFSET_EN bit determines whether the input-to-output phase offset is enabled; if the device is configured as the Slave, the input-to-output phase offset is always enabled. If enabled, the input-to-output phase offset can be adjusted by setting the PH_OFFSET[9:0] bits.

The input-to-output phase offset can be calculated as follows:

$$\text{Phase Offset (ns)} = \text{PH_OFFSET}[9:0] \times 0.61$$

3.11.5 FIVE PATHS OF T0 / T4 DPLL OUTPUTS

The T0 DPLL output and the T4 DPLL output are phase aligned with the T0 selected input clock and the T4 selected input clock respectively every 125 μ s period. Each DPLL has five output paths.

3.11.5.1 T0 Path

The five paths for T0 DPLL output are as follows:

- 77.76 MHz path - outputs a 77.76 MHz clock;
- 16E1/16T1 path - outputs a 16E1 or 16T1 clock, as selected by the IN_SONET_SDH bit;
- GSM/OBSAI/16E1/16T1 path - outputs a GSM, OBSAI, 16E1 or 16T1 clock, as selected by the T0_GSM_OBSAI_16E1_16T1_SEL[1:0] bits;
- 12E1/24T1/E3/T3 path - outputs a 12E1, 24T1, E3 or T3 clock, as selected by the T0_12E1_24T1_E3_T3_SEL[1:0] bits.
- ETH path - outputs a 25 MHz clock.

T0 selected input clock is compared with a T0 DPLL output for DPLL locking. The output can only be derived from the 77.76 MHz path or the 16E1/16T1 path. The output path is automatically selected and the output is automatically divided to get the same frequency as the T0 selected input clock.

The T0 DPLL 77.76 MHz output or an 8 kHz signal derived from it can be provided for the T4 DPLL input clock selection (refer to [Chapter 3.6 T0 / T4 DPLL Input Clock Selection](#)).

T0 DPLL outputs are provided for T0/T4 APLL or device output process.

3.11.5.2 T4 Path

The five paths for T4 DPLL output are as follows:

- 77.76 MHz path - outputs a 77.76 MHz clock;
- 16E1/16T1 path - outputs a 16E1 or 16T1 clock, as selected by the IN_SONET_SDH bit;
- GSM/GPS/16E1/16T1 path - outputs a GSM, GPS, 16E1 or 16T1 clock, as selected by the T4_GSM_GPS_16E1_16T1_SEL[1:0] bits;
- 12E1/24T1/E3/T3 path - outputs a 12E1, 24T1, E3 or T3 clock, as selected by the T4_12E1_24T1_E3_T3_SEL[1:0] bits.
- ETH path - outputs a 25 MHz clock.

T4 selected input clock is compared with a T4 DPLL output for DPLL locking. The output can be derived from the 77.76 MHz path or the

16E1/16T1 path. In this case, the output path is automatically selected and the output is automatically divided to get the same frequency as the T4 selected input clock.

In addition, T4 selected input clock is compared with the T0 selected input clock to get the phase difference between T0 and T4 selected input clocks, as determined by the T4_TEST_T0_PH bit.

T4 DPLL outputs are provided for T0/T4 APLL or device output process.

Table 22: Related Bit / Register in Chapter 3.11

Bit	Register	Address (Hex)
MULTI_PH_APP	PHASE_LOSS_COARSE_LIMIT_CNFG	5A *
T0_LIMIT	T0_BW_OVERSHOOT_CNFG	59
PBO_EN	MON_SW_PBO_CNFG	0B
PBO_FREZ		
PH_MON_PBO_EN	PHASE_MON_PBO_CNFG	78
PH_MON_EN		
PH_TR_MON_LIMIT[3:0]		
PH_OFFSET_EN	PHASE_OFFSET[9:8]_CNFG	7B
PH_OFFSET[9:0]	PHASE_OFFSET[9:8]_CNFG, PHASE_OFFSET[7:0]_CNFG	7B, 7A
IN_SONET_SDH	INPUT_MODE_CNFG	09
T0_GSM_OBSAI_16E1_16T1_SEL[1:0]	T0_DPLL_APLL_PATH_CNFG	55
T0_12E1_24T1_E3_T3_SEL[1:0]		
T4_GSM_GPS_16E1_16T1_SEL[1:0]	T4_DPLL_APLL_PATH_CNFG	60
T4_12E1_24T1_E3_T3_SEL[1:0]		
T4_TEST_T0_PH	T4_INPUT_SEL_CNFG	51
T4_T0_SEL	T4_T0_REG_SEL_CNFG	07

Note: * The setting in the 5A register is either for T0 path or for T4 path, as determined by the T4_T0_SEL bit.

3.12 T0 / T4 APLL

A T0 APLL and a T4 APLL are provided for a better jitter and wander performance of the device output clocks.

The bandwidths of the T0/T4 APLL are set by the T0_APLL_BW[1:0] / T4_APLL_BW[1:0] bits respectively. The lower the bandwidth is, the better the jitter and wander performance of the T0/T4 APLL output are.

The input of the T0/T4 APLL can be derived from one of the T0 and T4 DPLL outputs, as selected by the T0_APLL_PATH[3:0] / T4_APLL_PATH[3:0] bits respectively.

Both the APLL and DPLL outputs are provided for selection for the device output.

Table 23: Related Bit / Register in Chapter 3.12

Bit	Register	Address (Hex)
T0_APLL_BW[1:0]	T0_T4_APLL_BW_CNFG	6A
T4_APLL_BW[1:0]		
T0_APLL_PATH[3:0]	T0_DPLL_APLL_PATH_CNFG	55
T4_APLL_PATH[3:0]	T4_DPLL_APLL_PATH_CNFG	60

3.13 OUTPUT CLOCKS & FRAME SYNC SIGNALS

The device supports 5 output clocks and 2 frame sync output signals altogether.

Table 24: Outputs on OUT1 ~ OUT5 if Derived from T0/T4 DPLL Outputs

OUTn_DIVIDER[3:0] (Output Divider) ¹	Outputs on OUT1 ~ OUT5 if derived from T0/T4 DPLL Outputs ²										
	77.76 MHz	12E1	16E1	24T1	16T1	E3	T3	GSM (26 MHz)	ETH	OBSAI (30.72 MHz)	GPS (40 MHz)
0000	Output is disabled (output low).										
0001											
0010		12E1	16E1	24T1	16T1	E3	T3		25 MHz		
0011		6E1	8E1	12T1	8T1			13 MHz		15.36 MHz	20 MHz
0100		3E1	4E1	6T1	4T1						10 MHz
0101		2E1		4T1							
0110			2E1	3T1	2T1						5 MHz
0111		E1		2T1							
1000			E1		T1						
1001				T1							
1010	64 kHz										
1011	8 kHz										
1100	2 kHz										
1101	400 Hz										
1110	1Hz										
1111	Output is disabled (output high).										

Note:
 1. $1 \leq n \leq 5$. Each output is assigned a frequency divider.
 2. E1 = 2.048 MHz, T1 = 1.544 MHz, E3 = 34.368 MHz, T3 = 44.736 MHz. The blank cell means the configuration is reserved.

3.13.1 OUTPUT CLOCKS

The device provides 5 output clocks.

According to the output port technology, the output ports support the following technologies:

- PECL/LVDS;
- CMOS.

OUT1 ~ OUT3 output CMOS signals.

OUT4 and OUT5 output PECL or LVDS signals, as selected by the OUT4_PECL_LVDS bit and the OUT5_PECL_LVDS bit respectively.

The outputs on OUT1 ~ OUT5 are variable, depending on the signals derived from the T0/T4 DPLL and T0/T4 APLL outputs, and the corresponding OUTn_PATH_SEL[3:0] bits ($1 \leq n \leq 5$). The derived signal can be from the T0/T4 DPLL and T0/T4 APLL outputs, as selected by the corresponding OUTn_PATH_SEL[3:0] bits ($1 \leq n \leq 5$). If the signal is derived from one of the T0/T4 DPLL outputs, please refer to Table 24 for the output frequency. If the signal is derived from the T0/T4 APLL output, please refer to Table 25 for the output frequency.

The outputs on OUT1 to OUT5 can be inverted, as determined by the corresponding OUTn_INV bit ($1 \leq n \leq 5$).

All the output clocks derived from T0/T4 selected input clock are aligned with the T0/T4 selected input clock respectively every 125 μ s period.

Table 25: Outputs on OUT1 ~ OUT5 if Derived from T0/T4 APLL

OUTn_DIVIDER[3:0] (Output Divider) ¹	Outputs on OUT1 ~ OUT5 if derived from T0/T4 APLL Output ²										
	77.76 MHz X 4	12E1 X 4	16E1 X 4	24T1 X 4	16T1 X 4	E3	T3	GSM (26 MHz X 2)	OBSAI (30.72 MHz X 10)	GPS (40 MHz)	ETH
0000	Output is disabled (output low).										
0001	622.08 MHz ³										625 MHz
0010	311.04 MHz ³	48E1	64E1	96T1	64T1	E3	T3	104 MHz	307.2 MHz	40 MHz	125 MHz
0011	155.52 MHz	24E1	32E1	48T1	32T1			52 MHz	153.6 MHz	20 MHz	312.5 MHz
0100	77.76 MHz	12E1	16E1	24T1	16T1			26 MHz	76.8 MHz	10 MHz	156.25 MHz
0101	51.84 MHz	8E1		16T1				13 MHz			
0110	38.88 MHz	6E1	8E1	12T1	8T1				38.4 MHz	5 MHz	
0111	25.92 MHz	4E1		8T1							
1000	19.44 MHz	3E1	4E1	6T1	4T1						
1001		2E1		4T1					61.44 MHz		125 MHz
1010			2E1	3T1	2T1				30.72 MHz		
1011	6.48 MHz	E1		2T1					15.36 MHz		
1100			E1		T1				7.68 MHz		
1101				T1					3.84 MHz		
1110											
1111	Output is disabled (output high).										

Note:
 1. $1 \leq n \leq 5$. Each output is assigned a frequency divider.
 2. In the APLL, the selected T0/T4 DPLL output may be multiplied. E1 = 2.048 MHz, T1 = 1.544 MHz, E3 = 34.368 MHz, T3 = 44.736 MHz. The blank cell means the configuration is reserved.
 3. The 622.08 MHz and 311.04 MHz differential signals are only output on OUT6 and OUT7.

3.13.2 FRAME SYNC OUTPUT SIGNALS

An 8 kHz and a 2 kHz frame sync signals are output on the FRSYNC_8K and MFRSYNC_2K pins if enabled by the 8K_EN and 2K_EN bits respectively. They are CMOS outputs.

The two frame sync signals are derived from the T0 APLL output and are aligned with the output clock. They can be synchronized to the frame sync input signal.

If the frame sync input signal with respect to the T0 selected input clock is above a limit set by the SYNC_MON_LIMT[2:0] bits, an external sync alarm will be raised and EX_SYNC1 is disabled to synchronize the frame sync output signals. The external sync alarm is cleared once EX_SYNC1 with respect to the T0 selected input clock is within the limit. If it is within the limit, whether EX_SYNC1 is enabled to synchronize the frame sync output signal is determined by the AUTO_EXT_SYNC_EN bit and the EXT_SYNC_EN bit. Refer to Table 26 for details.

When the frame sync input signal is enabled to synchronize the frame sync output signal, it should be adjusted to align itself with the T0 selected input clock. Nominally, the falling edge of EX_SYNC1 is aligned with the rising edge of the T0 selected input clock. EX_SYNC1 may be 0.5 UI early/late or 1 UI late due to the circuit and board wiring delays. Setting the sampling of EX_SYNC1 by the SYNC_PH1[1:0] bits will compensate this early/late. Refer to Figure 9 to Figure 12.

The EX_SYNC_ALARM_MON bit indicates whether EX_SYNC1 is in external sync alarm status. The external sync alarm is indicated by the EX_SYNC_ALARM¹ bit. If the EX_SYNC_ALARM² bit is '1', the occurrence of the external sync alarm will trigger an interrupt.

The 8 kHz and the 2 kHz frame sync output signals can be inverted by setting the 8K_INV and 2K_INV bits respectively. The frame sync outputs can be 50:50 duty cycle or pulsed, as determined by the 8K_PUL and 2K_PUL bits respectively. When they are pulsed, the pulse width is defined by the period of OUT1; and they are pulsed on the position of the falling or rising edge of the standard 50:50 duty cycle, as selected by the 2K_8K_PUL_POSITION bit.

2K/8K pulse mode can also be supported. When the pulse is positive, 1UI late EX_SYNC1 shall be set. 2K pulse is output by writing '0x71' to the FR_MFR_SYNC_CNFG register (74H); 8K pulse is output by writing '0x6C' to the FR_MFR_SYNC_CNFG register. When the pulse is negative, on target EX_SYNC1 shall be set. 2K pulse is output by writing '0x73' to the FR_MFR_SYNC_CNFG register; 8K pulse is output by writing '0x64' to the FR_MFR_SYNC_CNFG register. To align EX_SYNC1 with Frame sync output signals, the pulse width only can be 38.88 MHz, 19.44 MHz and 6.48 MHz for master/slave application. Refer to Figure 13 and Figure 14.

Table 26: Synchronization Control

AUTO_EXT_SYNC_EN	EXT_SYNC_EN	Synchronization
don't-care	0	Disabled
0	1	Enabled
1	1	Enabled if the T0 selected input clock is IN5; otherwise, disabled.

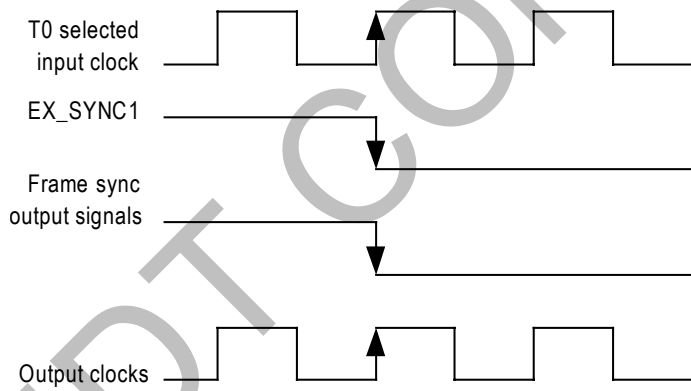

Figure 9. On Target Frame Sync Input Signal Timing

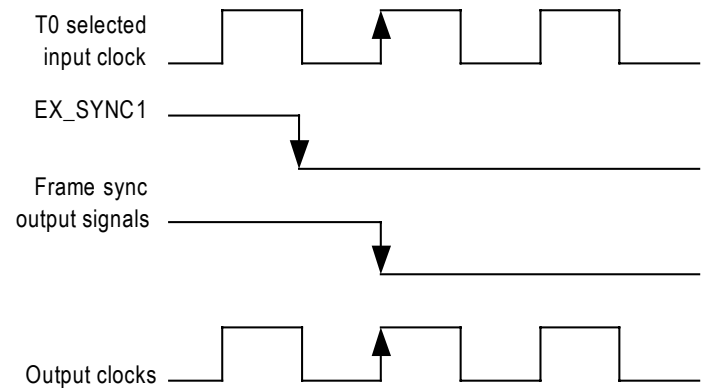

Figure 10. 0.5 UI Early Frame Sync Input Signal Timing

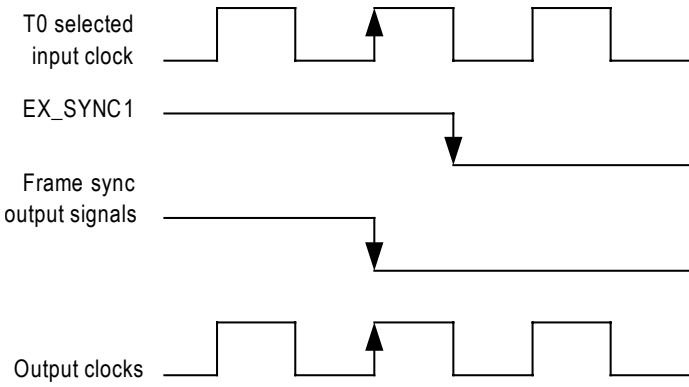

Figure 11. 0.5 UI Late Frame Sync Input Signal Timing

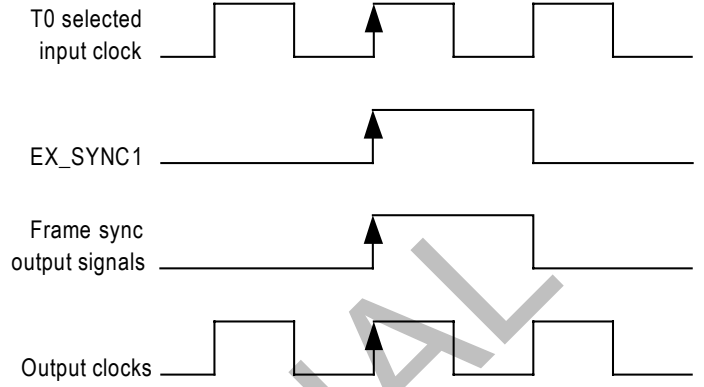

Figure 13. 1 UI Late Frame Sync 2K/8K Pulse Input Signal Timing

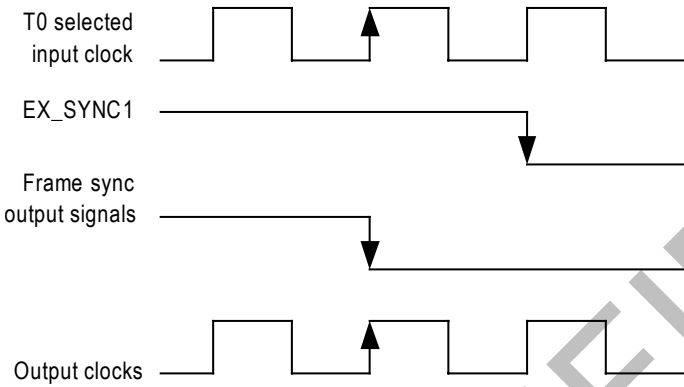

Figure 12. 1 UI Late Frame Sync Input Signal Timing

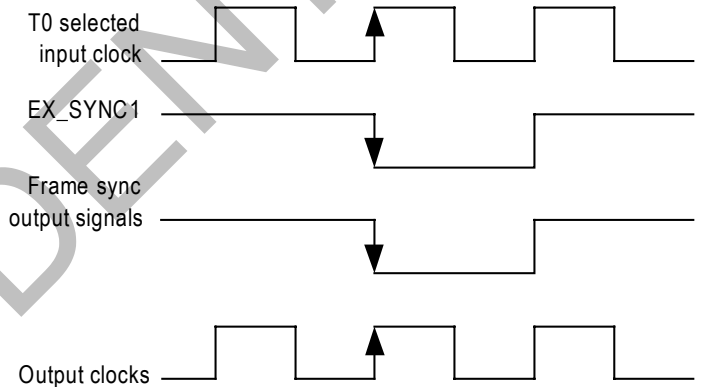

Figure 14. On Target Frame Sync 2K/8K Pulse Input Signal Timing

Table 27: Related Bit / Register in Chapter 3.13

Bit	Register	Address (Hex)
OUT4_PECL_LVDS	DIFFERENTIAL_IN_OUT_OSCI_CNFG	0A
OUT5_PECL_LVDS		
OUTn_PATH_SEL[3:0] (1 ≤ n ≤ 5)	OUT1_FREQ_CNFG ~ OUT5_FREQ_CNFG	6D ~ 71
OUTn_DIVIDER[3:0] (1 ≤ n ≤ 5)		
IN_SONET_SDH	INPUT_MODE_CNFG	09
AUTO_EXT_SYNC_EN		
EXT_SYNC_EN		
8K_EN	FR_MFR_SYNC_CNFG	74
2K_EN		
8K_INV		
2K_INV		
8K_PUL		
2K_PUL		
2K_8K_PUL_POSITION		
SYNC_MON_LIMIT[2:0]	SYNC_MONITOR_CNFG	7C
SYNC_PH1[1:0]	SYNC_PHASE_CNFG	7D
EX_SYNC_ALARM_MON	OPERATING_STS	52
EX_SYNC_ALARM ¹	INTERRUPTS3_STS	0F
EX_SYNC_ALARM ²	INTERRUPTS3_ENABLE_CNFG	12

3.14 MASTER / SLAVE CONFIGURATION

Master / Slave configuration is only supported by the T0 path of the device.

Two devices should be used together in order to:

- Enable system protection against single chip failure;
- Guarantee no service interrupt during system maintenance, such as software or hardware upgrade.

Of the two devices, one is configured as the Master and the other is configured as the Slave. The configuration is made by the MS/SL pin and the MS_SL_CTRL bit (b0, 13H), as shown in Table 28:

Table 28: Device Master / Slave Control

Master / Slave Control		Result
MS/SL pin	MS_SL_CTRL Bit	
High	0	Master
	1	Slave
Low	0	Slave
	1	Master

In this application, all the output clocks derived from the T0 selected input clock and the frame sync output signals from the two devices are at the same frequency offset and phase. Refer to Chapter 3.13.2 Frame SYNC Output Signals for details.

The difference between the Master and the Slave is: in the Master, the IN5 should not be selected by the T0 DPLL; in the Slave, the following functions are automatically forced:

- The T0 selected input clock is IN5;
- T0 PBO is disabled;
- T0 DPLL operates at the acquisition bandwidth and damping factor;
- EX_SYNC1 is used for synchronization;
- T0 DPLL operates in Locked mode.

In the Slave, the corresponding registers of the above forced functions can still be configured, but their configuration does not take any effect. The frequency of the T0 selected input clock IN5 is recommended to be 6.48 MHz.

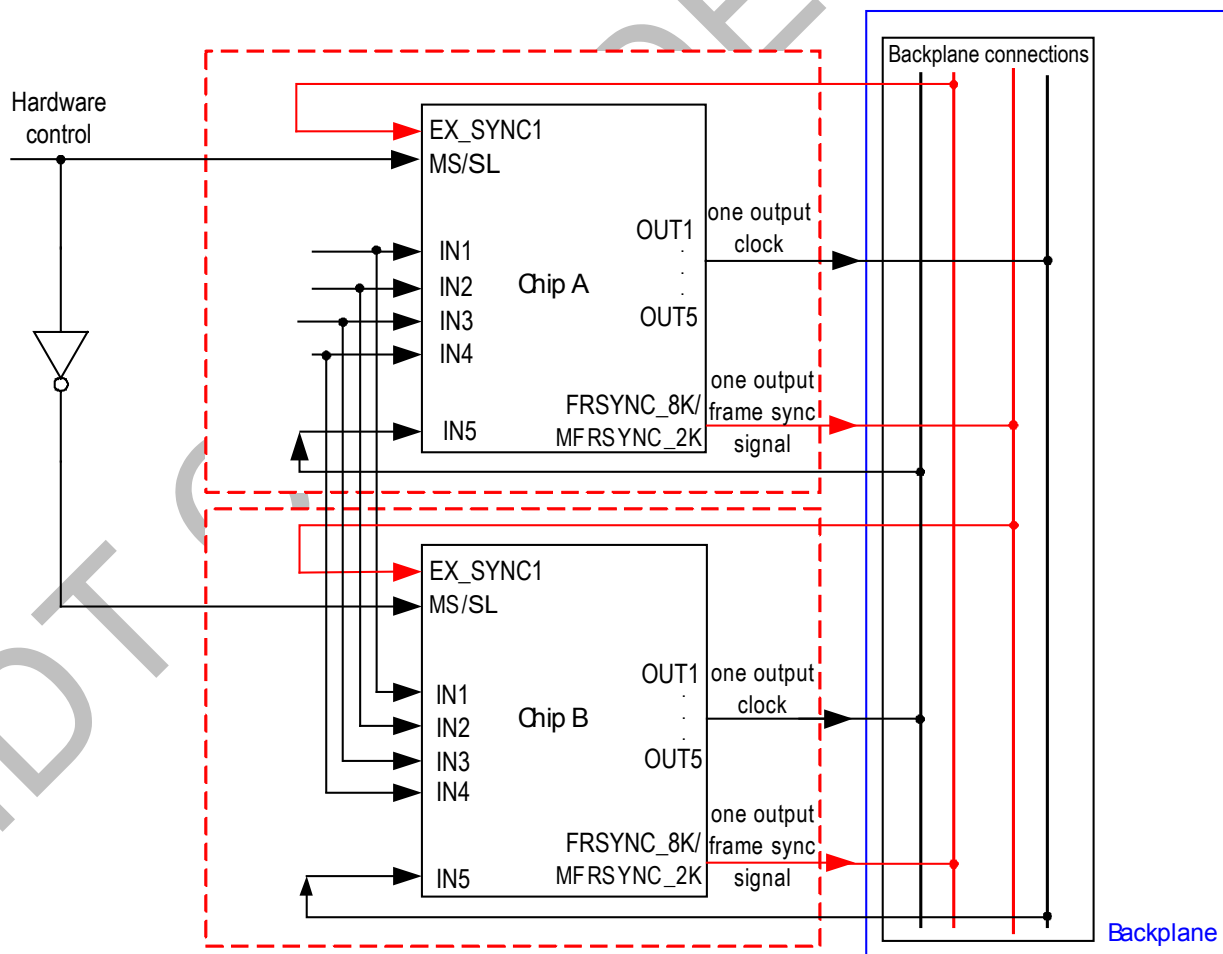

Figure 15. Physical Connection Between Two Devices

3.15 INTERRUPT SUMMARY

The interrupt sources of the device are as follows:

- T4 DPLL locking status change
- Input clocks for T0 path validity change
- T0 selected input clock fail
- No qualified input clock for T4 path is available
- T0 DPLL operating mode switch
- External sync alarm

All of the above interrupt events are indicated by the corresponding interrupt status bit. If the corresponding interrupt enable bit is set, any of the interrupts can be reported by the INT_REQ pin. The output characteristics on the INT_REQ pin are determined by the HZ_EN bit and the INT_POL bit.

Interrupt events are cleared by writing a '1' to the corresponding interrupt status bit. The INT_REQ pin will be inactive only when all the pending enabled interrupts are cleared.

In addition, the interrupt of T0 selected input clock fail can be reported by the TDO pin, as determined by the LOS_FLAG_TO_TDO bit.

Table 29: Related Bit / Register in Chapter 3.15

Bit	Register	Address (Hex)
HZ_EN	INTERRUPT_CNFG	0C
INT_POL		
LOS_FLAG_TO_TDO	MON_SW_PBO_CNFG	0B

3.16 T0 AND T4 SUMMARY

The main features supported by the T0 path are as follows:

- Phase lock alarm;
- Forced or Automatic input clock selection/switch;
- 3 primary and 3 secondary, temporary DPLL operating modes, switched automatically or under external control;
- Automatic switch between starting, acquisition and locked bandwidths/damping factors;
- Programmable DPLL bandwidths from 0.5 mHz to 560 Hz in 19 steps;
- Programmable damping factors: 1.2, 2.5, 5, 10 and 20;
- Fast loss, coarse phase loss, fine phase loss and hard limit exceeding monitoring;
- Output phase and frequency offset limited;
- Automatic Instantaneous, Automatic Slow Averaged, Automatic Fast Averaged or Manual holdover frequency offset acquiring;
- PBO to minimize output phase transients;
- Programmable output phase offset;
- Low jitter multiple clock outputs with programmable polarity;
- Low jitter 2 kHz and 8 kHz frame sync signal outputs with programmable pulse width and polarity;
- Master / Slave application to enable system protection against single device failure.

The main features supported by the T4 path are as follows:

- Forced or Automatic input clock selection/switch;
- Locking to T0 DPLL output;
- 3 DPLL operating modes, switched automatically or under external control;
- Programmable DPLL bandwidth: 18 Hz, 35 Hz, 70 Hz and 560 Hz;
- Programmable damping factor: 1.2, 2.5, 5, 10 and 20;
- Fast loss, coarse phase loss, fine phase loss and hard limit exceeding monitoring;
- Output phase and frequency offset limited;
- Automatic Instantaneous holdover frequency offset;
- Low jitter multiple clock outputs with programmable polarity.

3.17 POWER SUPPLY FILTERING TECHNIQUES

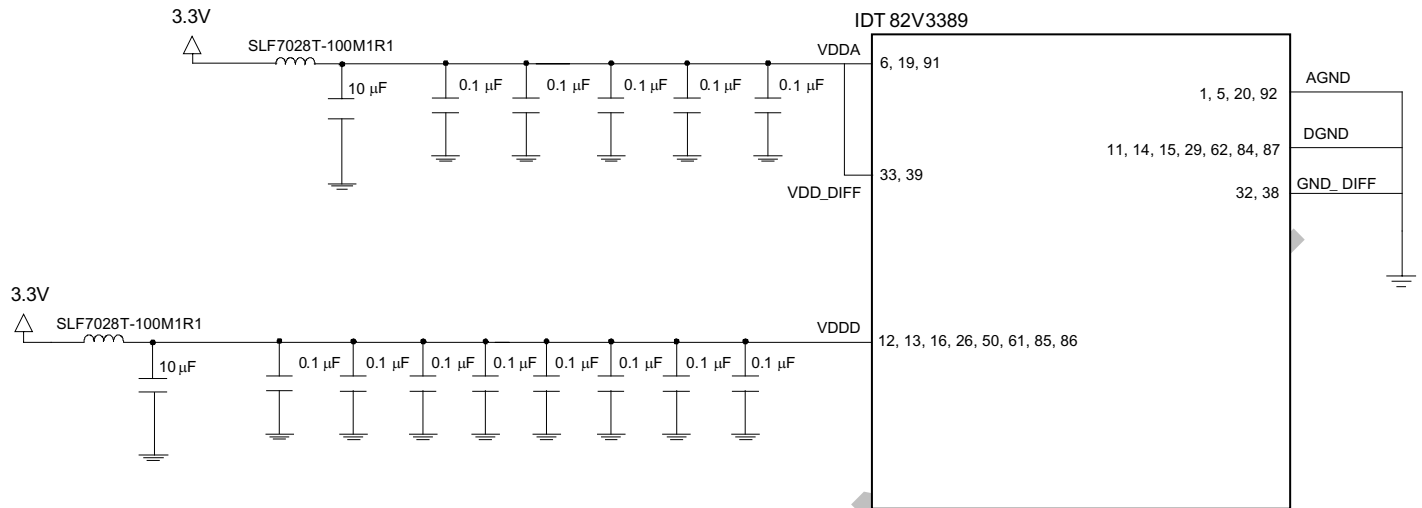

Figure 16. IDT82V3389 Power Decoupling Scheme

To achieve optimum jitter performance, power supply filtering is required to minimize supply noise modulation of the output clocks. The common sources of power supply noise are switch power supplies and the high switching noise from the outputs to the internal PLL. The IDT82V3389 provides separate VDDA power pins for the internal analog PLL, VDD_DIFF for the differential output driver circuit and VDDD pins for the core logic as well as I/O driver circuits.

To minimize switching power supply noise generated by the switching regulator, the power supply output should be filtering with sufficient bulk capacity to minimize ripple and 0.1 uF (0402 case size, ceramic) caps to filter out the switching transients.

For the IDT82V3389, the decoupling for VDDA, VDD_DIFF and VDDD are handled individually. VDDD, VDD_DIFF and VDDA should be individually connected to the power supply plane through vias, and bypass capacitors should be used for each pin. Figure 16 illustrated how bypass capacitor and ferrite bead should be connected to power pins.

The analog power supply VDDA and VDD_DIFF should have low impedance. This can be achieved by using one 10 uF (1210 case size, ceramic) and at least four 0.1 uF (0402 case size, ceramic) capacitors in parallel. The 0.1 uF (0402 case size, ceramic) capacitors must be placed right next to the VDDA and VDD_DIFF pins as close as possible. Note that the 10 uF capacitor must be of 1210 case size, and it must be ceramic for lowest ESR (Effective Series Resistance) possible. The 0.1 uF should be of case size 0402, this offers the lowest ESL (Effective Series Inductance) to achieve low impedance towards the high speed range.

For VDDD, at least ten 0.1 uF (0402 case size, ceramic) and one 10 uF (1210 case size, ceramic) capacitors are recommended. The 0.1 uF capacitors should be placed as close to the VDDD pins as possible.

Please refer to evaluation board schematic for details.

4 TYPICAL APPLICATION

The device supports Master / Slave application, as shown in Figure 17:

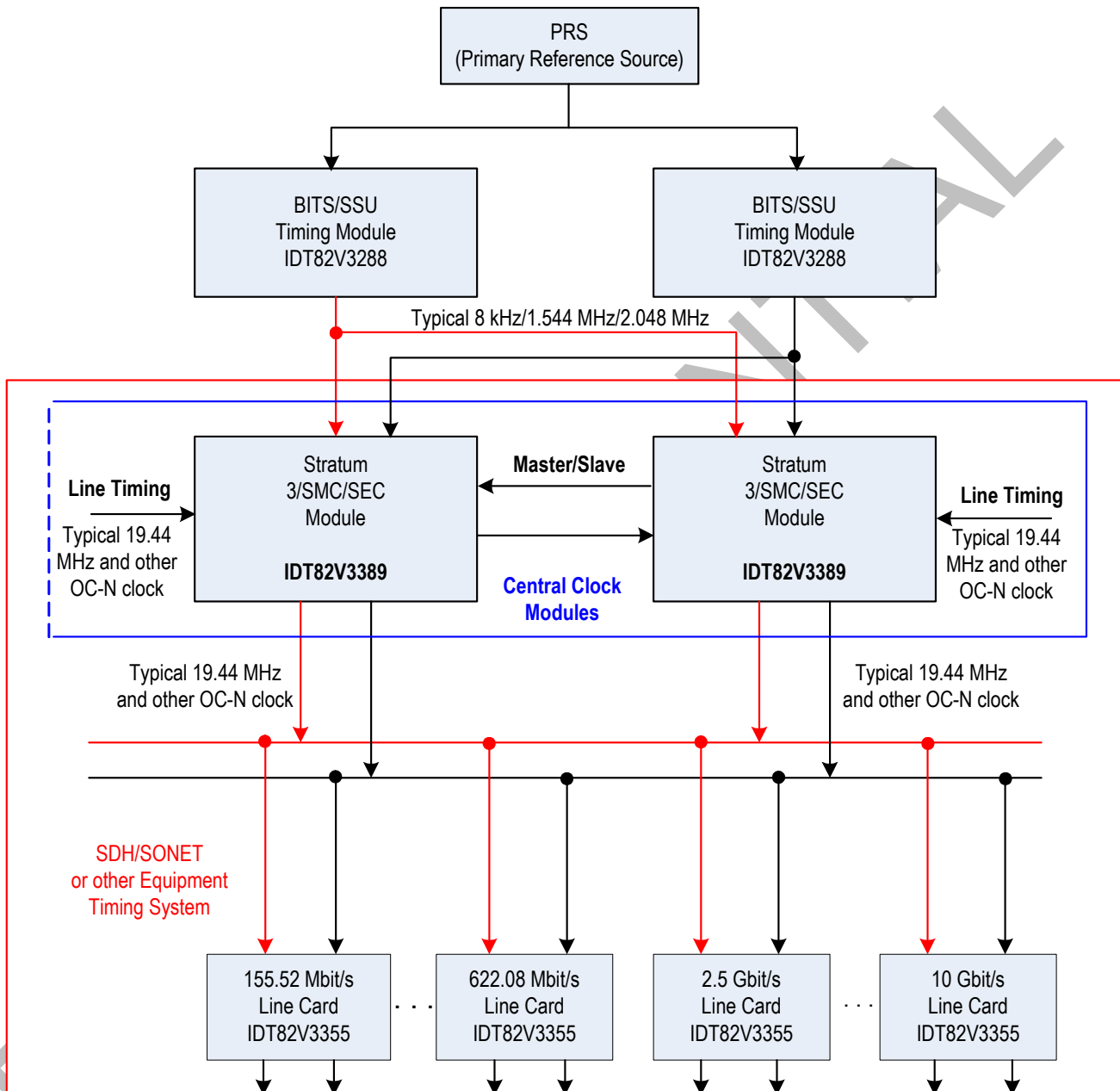

Figure 17. Typical Application

4.1 MASTER / SLAVE APPLICATION

Master / Slave application is only supported by the T0 path of the device.

In Master / Slave application, two devices should be used together. Of the two devices, one is configured as the Master and the other is configured as the Slave. Refer to Chapter 3.14 Master / Slave Configuration for details.

5 MICROPROCESSOR INTERFACE

The microprocessor interface provides access to read and write the registers in the device. The microprocessor interface supports the following five modes:

- EPROM mode;
- Multiplexed mode;
- Intel mode;
- Motorola mode;
- Serial mode.

The microprocessor interface mode is selected by the MPU_SEL_CNFG[2:0] bits (b2~0, 7FH). The interface pins in different interface modes are listed in [Table 30](#) and [Table 31](#):

Table 30: Microprocessor Interface

MPU_SEL_CNFG[2:0] bits	Microprocessor Interface Mode	Interface Pins
001	EPROM	CS, A[6:0], AD[7:0]
010	Multiplexed	CS, ALE, WR, RD, AD[7:0], RDY
011	Intel	CS, WR, RD, A[6:0], AD[7:0], RDY
100	Motorola	CS, WR, A[6:0], AD[7:0], RDY
101	Serial	CS, SCLK, SDI, SDO, CLKE

Table 31: Microprocessor Interface Pins

PIN	MODE				
	EPROM	MULTIPLEXED	INTEL	MOTOROLA	SERIAL
A0 / SDI	OUTPUT	INPUT (Note 1)	INPUT	INPUT	INPUT
A1 / CLKE	OUTPUT	INPUT (Note 1)	INPUT	INPUT	INPUT
A2	OUTPUT	INPUT (Note 1)	INPUT	INPUT	INPUT (Note 1)
A3	OUTPUT	INPUT (Note 1)	INPUT	INPUT	INPUT (Note 1)
A4	OUTPUT	INPUT (Note 1)	INPUT	INPUT	INPUT (Note 1)
A5	OUTPUT	INPUT (Note 1)	INPUT	INPUT	INPUT (Note 1)
A6	OUTPUT	INPUT (Note 1)	INPUT	INPUT	INPUT (Note 1)
AD0/SD0	INPUT	INPUT/OUTPUT	INPUT/OUTPUT	INPUT/OUTPUT	OUTPUT
AD[7:1]	INPUT	INPUT/OUTPUT	INPUT/OUTPUT	INPUT/OUTPUT	INPUT (Note 1)
CS	OUTPUT	INPUT	INPUT	INPUT	INPUT
WR	INPUT (Note 1)	INPUT	INPUT	INPUT	INPUT (Note 1)
RD	INPUT (Note 1)	INPUT	INPUT	INPUT (Note 1)	INPUT (Note 1)
RDY (Note 2)	Output (Note 1)	OUTPUT	OUTPUT	OUTPUT	Output (Note 1)
ALE/SCLK	INPUT (Note 1)	INPUT	INPUT (Note 1)	INPUT (Note 1)	INPUT

After reset de-assertion, wait 10us for the mode to be active.
 Note 1: This pin is not used in this mode, this pin should be connected to ground
 Note 2: This pin is open drain

5.1 EPROM MODE

In this mode, the device is used with an EPROM. The configuration data will be automatically read from the EPROM after the device is powered on.

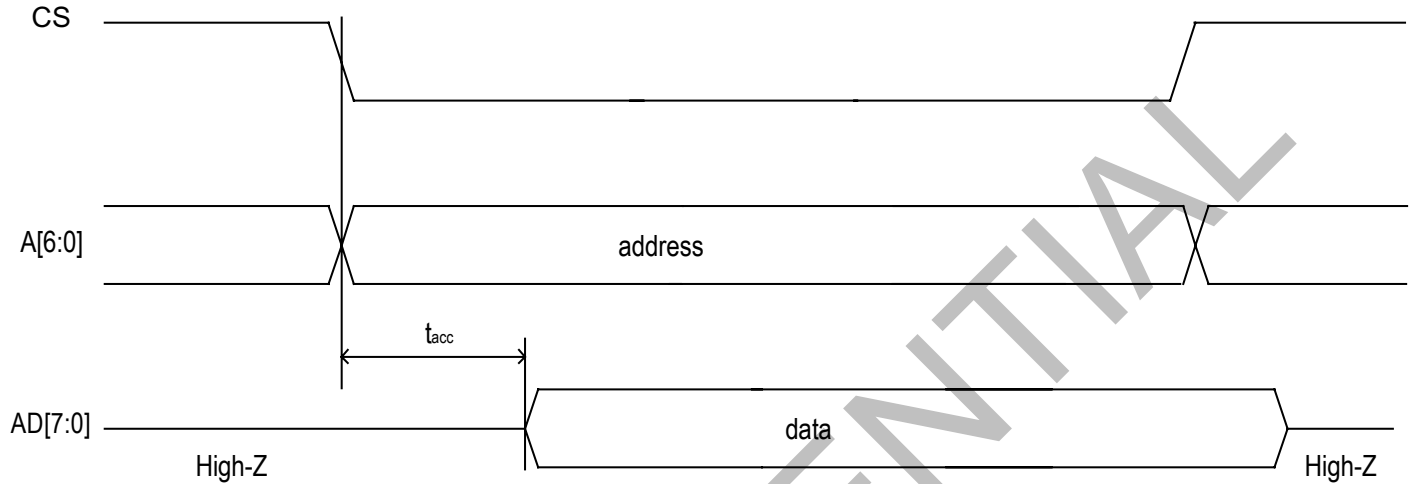

Figure 18. EPROM Access Timing Diagram

Table 32: Access Timing Characteristics in EPROM Mode

Symbol	Parameter	Min	Typ	Max	Unit
t_{acc}	CS to valid data delay time			920	ns

5.2 MULTIPLEXED MODE

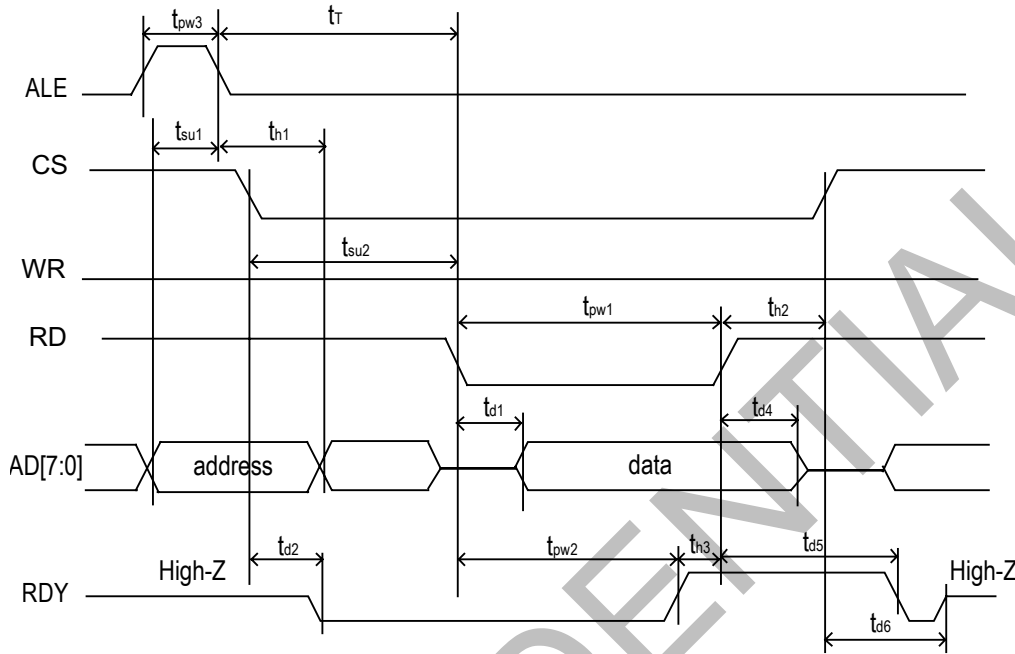

Figure 19. Multiplexed Read Timing Diagram

Table 33: Read Timing Characteristics in Multiplexed Mode

Symbol	Parameter	Min	Typ	Max	Unit
T	One cycle time of the master clock		12.86		ns
t_{in}	Delay of input pad		5		ns
t_{out}	Delay of output pad		5		ns
t_{su1}	Valid address to ALE falling edge setup time	2			ns
t_{su2}	Valid CS to Valid RD setup time	0			ns
t_{d1}	Valid RD to valid data delay time			5T + 10	ns
t_{d2}	Valid CS to valid RDY delay time		13		ns
t_{d4}	RD rising edge to AD[7:0] high impedance delay time		10		ns
t_{d5}	RD rising edge to RDY low delay time		13		ns
t_{d6}	CS rising edge to RDY release delay time		13		ns
t_{pw1}	Valid RD pulse width low	4.5T + 10 *			ns
t_{pw2}	Valid RDY pulse width low	4.5T + 10			ns
t_{pw3}	Valid ALE pulse width high	2			ns
t_{h1}	Valid address after ALE falling edge hold time	3			ns
t_{h2}	Valid CS after RD rising edge hold time	0			ns
t_{h3}	Valid RD after RDY rising edge hold time	0			ns
t_T	Time between ALE falling edge and RD falling edge	0			ns
t_{T1}	Time between consecutive Read-Read or Read-Write accesses (RD rising edge to ALE rising edge)	>T			ns

Note:

* Timing with RDY. If RDY is not used, t_{pw1} is 3.5T + 10.

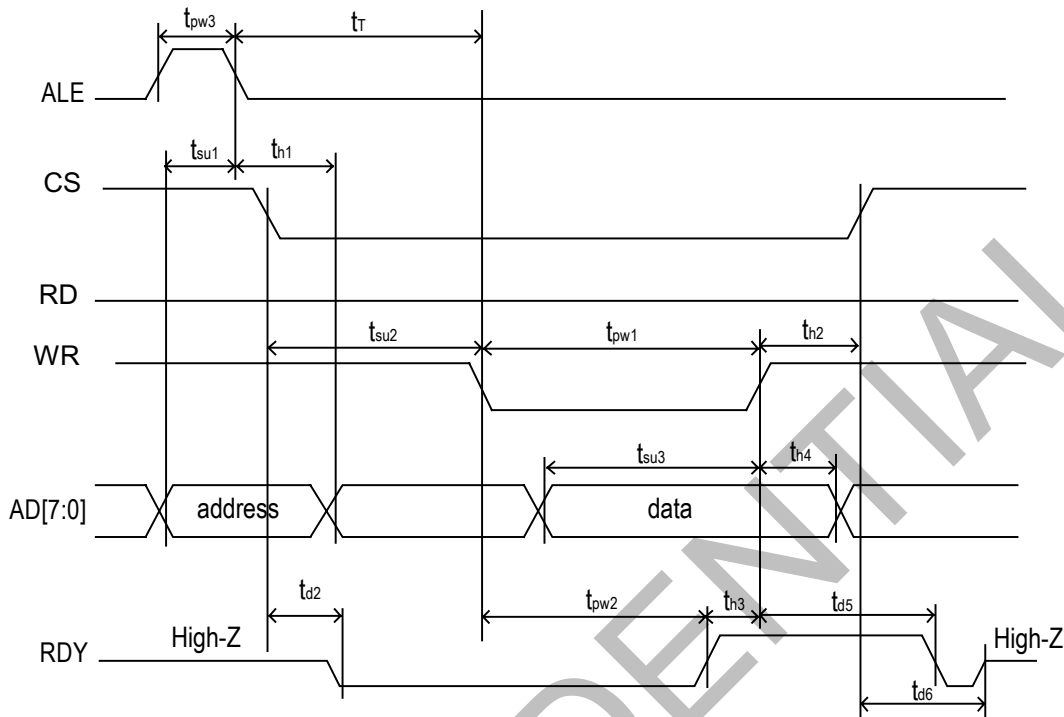

Figure 20. Multiplexed Write Timing Diagram

Table 34: Write Timing Characteristics in Multiplexed Mode

Symbol	Parameter	Min	Typ	Max	Unit
T	One cycle time of the master clock		12.86		ns
t_{in}	Delay of input pad		5		ns
t_{out}	Delay of output pad		5		ns
t_{su1}	Valid address to ALE falling edge setup time	2			ns
t_{su2}	Valid CS to valid WR setup time	0			ns
t_{su3}	Valid data to WR rising edge setup time	3			ns
t_{d2}	Valid CS to valid RDY delay time		13		ns
t_{d5}	WR rising edge to RDY low delay time		13		ns
t_{d6}	CS rising edge to RDY release delay time		13		ns
t_{pw1}	Valid WR pulse width low	$1.5T + 10$			ns
t_{pw2}	Valid RDY pulse width low	$1.5T + 10$			ns
t_{pw3}	Valid ALE pulse width high	2			ns
t_{h1}	Valid address after ALE falling edge hold time	3			ns
t_{h2}	Valid CS after WR rising edge hold time	0			ns
t_{h3}	Valid WR after RDY rising edge hold time	0			ns
t_{h4}	Valid data after WR rising edge hold time	9			ns
t_T	Time between ALE falling edge and WR falling edge	0			ns
t_{T1}	Time between consecutive Write-Read or Write-Write accesses (WR rising edge to ALE rising edge)	$>7T$			ns

5.3 INTEL MODE

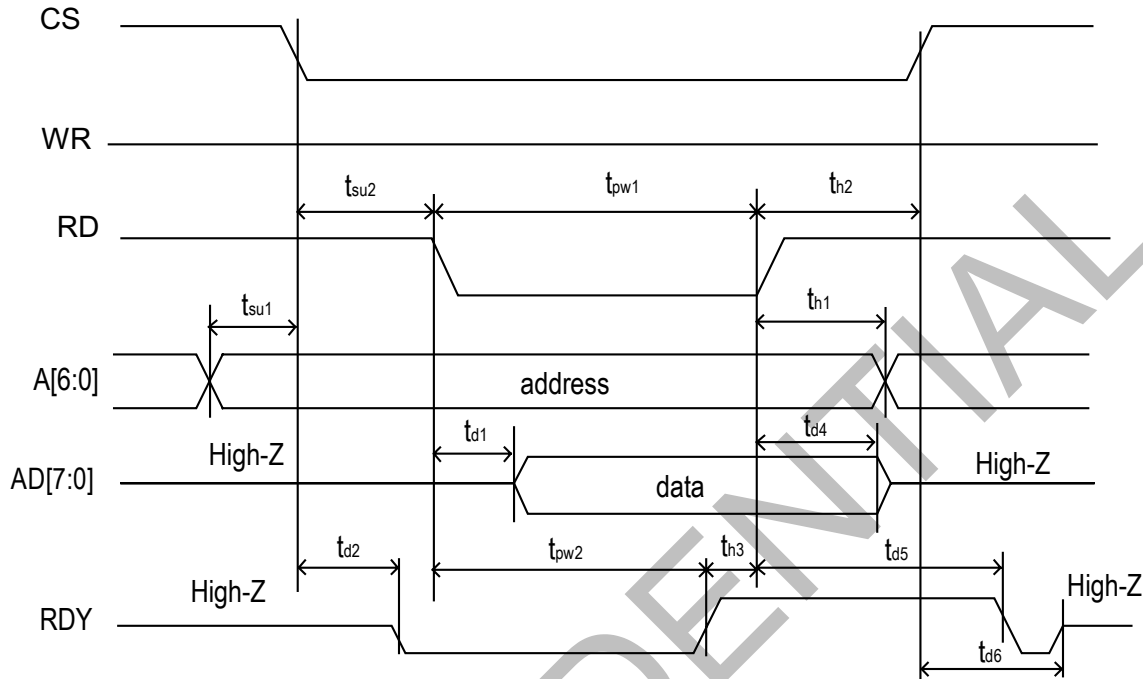

Figure 21. Intel Read Timing Diagram

Table 35: Read Timing Characteristics in Intel Mode

Symbol	Parameter	Min	Typ	Max	Unit
T	One cycle time of the master clock		12.86		ns
t _{in}	Delay of input pad		5		ns
t _{out}	Delay of output pad		5		ns
t _{su1}	Valid address to valid CS setup time	0			ns
t _{su2}	Valid CS to valid RD setup time	0			ns
t _{d1}	Valid RD to valid data delay time			5T + 10	ns
t _{d2}	Valid CS to valid RDY delay time		13		ns
t _{d4}	RD rising edge to AD[7:0] high impedance delay time		10		ns
t _{d5}	RD rising edge to RDY low delay time		13		ns
t _{d6}	CS rising edge to RDY release delay time		13		ns
t _{pw1}	Valid RD pulse width low	4.5T + 10 *			ns
t _{pw2}	Valid RDY pulse width low	4.5T + 10			ns
t _{h1}	Valid address after RD rising edge hold time	0			ns
t _{h2}	Valid CS after RD rising edge hold time	0			ns
t _{h3}	Valid RD after RDY rising edge hold time	0			ns
t _{T1}	Time between consecutive Read-Read or Read-Write accesses (RD rising edge to RD falling edge, or RD rising edge to WR falling edge)	>T			ns

Note:

* Timing with RDY. If RDY is not used, t_{pw1} is 3.5T + 10.

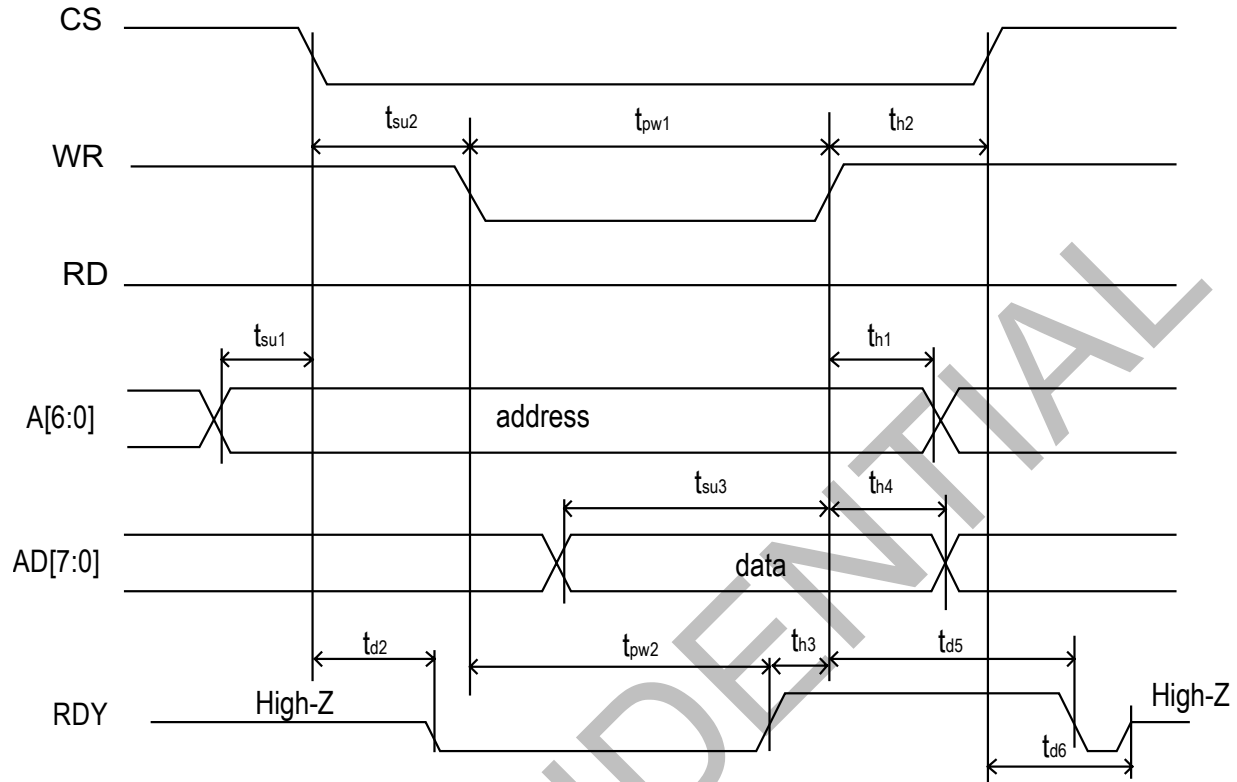

Figure 22. Intel Write Timing Diagram

Table 36: Write Timing Characteristics in Intel Mode

Symbol	Parameter	Min	Typ	Max	Unit
T	One cycle time of the master clock		12.86		ns
t_{in}	Delay of input pad		5		ns
t_{out}	Delay of output pad		5		ns
t_{su1}	Valid address to valid CS setup time	0			ns
t_{su2}	Valid CS to valid WR setup time	0			ns
t_{su3}	Valid data before WR rising edge setup time	3			ns
t_{d2}	Valid CS to valid RDY delay time		13		ns
t_{d5}	WR rising edge to RDY low delay time		13		ns
t_{d6}	CS rising edge to RDY release delay time		13		ns
t_{pw1}	Valid WR pulse width low	$1.5T + 10$			ns
t_{pw2}	Valid RDY pulse width low	$1.5T + 10$			ns
t_{h1}	Valid address after WR rising edge hold time	0			ns
t_{h2}	Valid CS after WR rising edge hold time	0			ns
t_{h3}	Valid WR after RDY rising edge hold time	0			ns
t_{h4}	Valid data after WR rising edge hold time	9			ns
t_{T1}	Time between consecutive Write-Read or Write-Write accesses (WR rising edge to WR falling edge, or WR rising edge to RD falling edge)	$>7T$			ns

5.4 MOTOROLA MODE

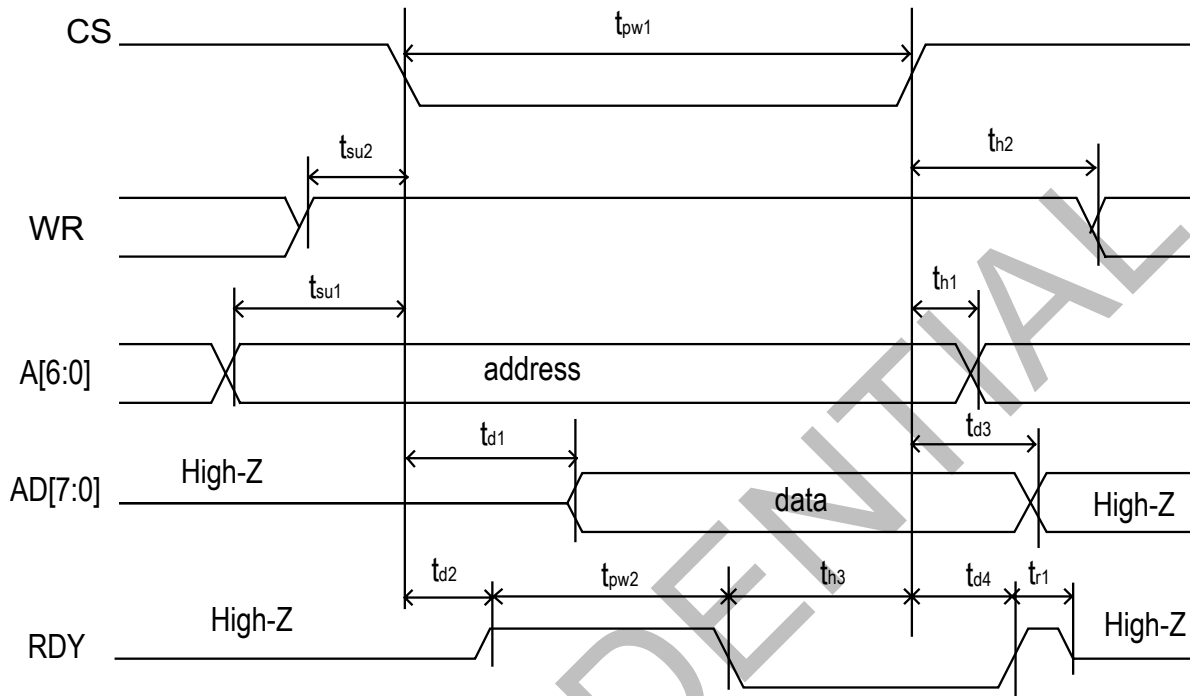

Figure 23. Motorola Read Timing Diagram

Table 37: Read Timing Characteristics in Motorola Mode

Symbol	Parameter	Min	Typ	Max	Unit
T	One cycle time of the master clock		12.86		
t_{in}	Delay of input pad		5		ns
t_{out}	Delay of output pad		5		ns
t_{su1}	Valid address to valid CS setup time	0			ns
t_{su2}	Valid WR to valid CS setup time	0			ns
t_{d1}	Valid CS to valid data delay time			5T + 10	ns
t_{d2}	Valid CS to valid RDY delay time		13		ns
t_{d3}	CS rising edge to AD[7:0] high impedance delay time		10		ns
t_{d4}	CS rising edge to RDY release delay time		13		ns
t_{pw1}	Valid CS pulse width low	4.5T + 10 *			ns
t_{pw2}	Valid RDY pulse width high	4.5T + 10			ns
t_{h1}	Valid address after CS rising edge hold time	0			ns
t_{h2}	Valid WR after CS rising edge hold time	0			ns
t_{h3}	Valid CS after RDY falling edge hold time	0			ns
t_{r1}	RDY release time		3		ns
t_{T1}	Time between consecutive Read-Read or Read-Write accesses (CS rising edge to CS falling edge)	> T			ns

Note:

* Timing with RDY. If RDY is not used, t_{pw1} is 3.5T + 10.

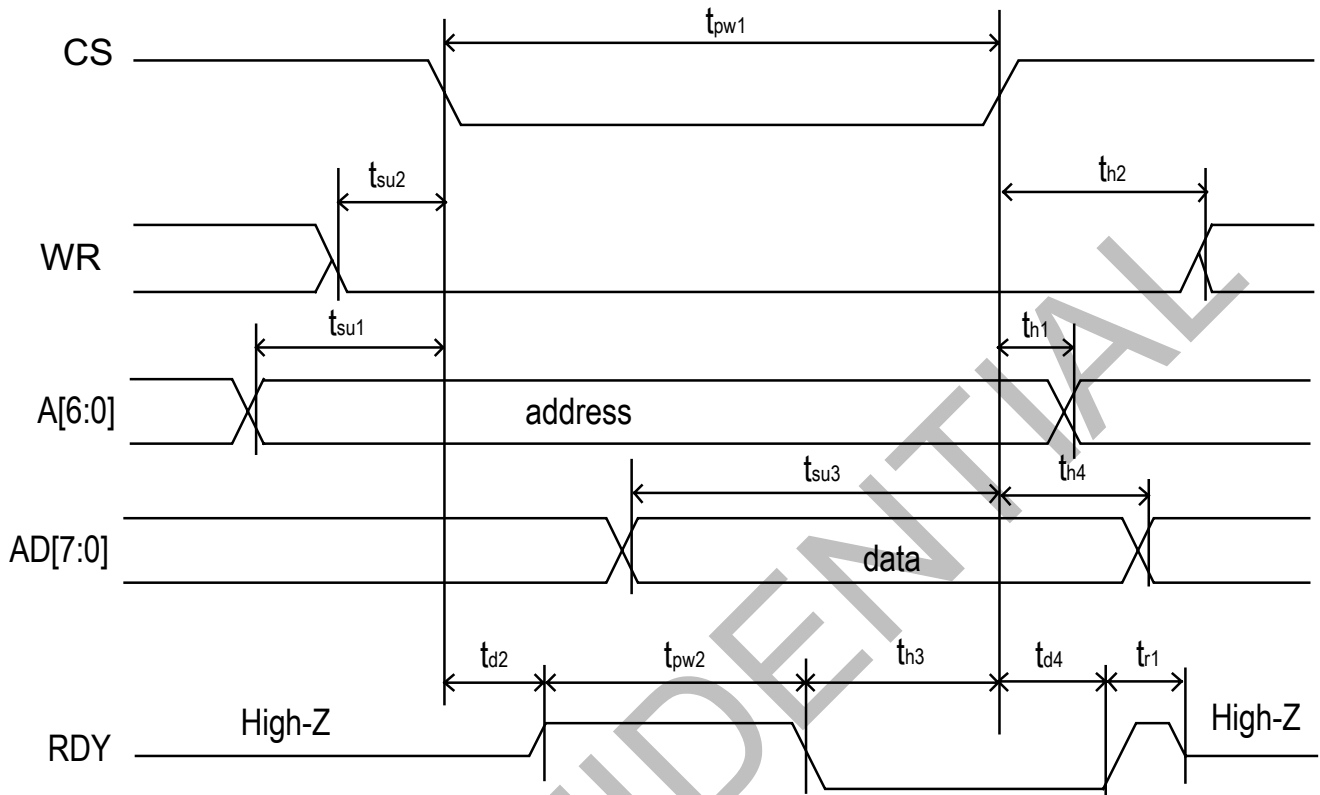

Figure 24. Motorola Write Timing Diagram

Table 38: Write Timing Characteristics in Motorola Mode

Symbol	Parameter	Min	Typ	Max	Unit
T	One cycle time of the master clock		12.86		ns
t_{in}	Delay of input pad		5		ns
t_{out}	Delay of output pad		5		ns
t_{su1}	Valid address to valid CS setup time	0			ns
t_{su2}	Valid WR to valid CS setup time	0			ns
t_{su3}	Valid data before CS rising edge setup time	3			ns
t_{d2}	Valid CS to valid RDY delay time		13		ns
t_{d4}	CS rising edge to RDY release delay time		13		ns
t_{pw1}	Valid CS pulse width low	$1.5T + 10$			ns
t_{pw2}	Valid RDY pulse width high	$1.5T + 10$			ns
t_{h1}	Valid address after valid CS rising edge hold time	0			ns
t_{h2}	Valid WR after valid CS rising edge hold time	0			ns
t_{h3}	Valid CS after RDY falling edge hold time	0			ns
t_{h4}	Valid data after valid CS rising edge hold time	9			ns
t_{r1}	RDY release time		3		ns
t_{T1}	Time between consecutive Write-Write or Write-Read accesses (CS rising edge to CS falling edge)	$> 7T$			ns

5.5 SERIAL MODE

In a read operation, the active edge of SCLK is selected by CLKE. When CLKE is asserted low, data on SDO will be clocked out on the rising edge of SCLK. When CLKE is asserted high, data on SDO will be clocked out on the falling edge of SCLK.

In a write operation, data on SDI will be clocked in on the rising edge of SCLK.

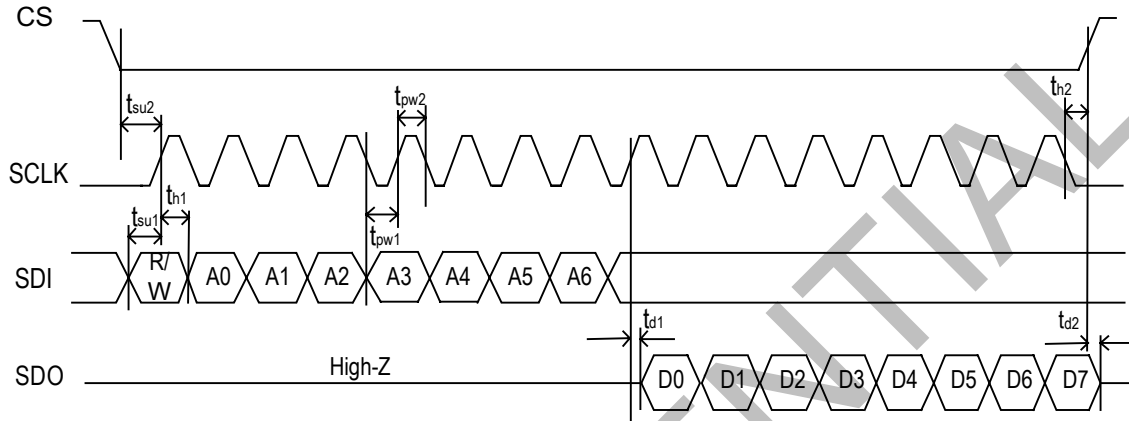

Figure 25. Serial Read Timing Diagram (CLKE Asserted Low)

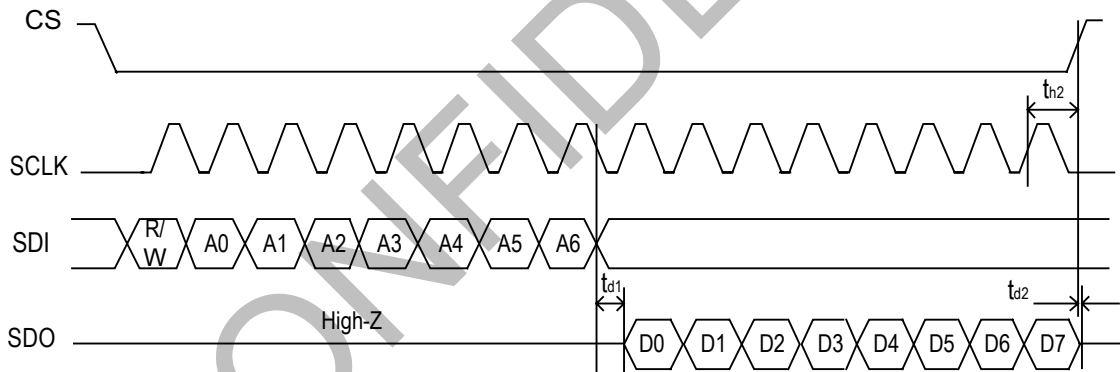

Figure 26. Serial Read Timing Diagram (CLKE Asserted High)

Table 39: Read Timing Characteristics in Serial Mode

Symbol	Parameter	Min	Typ	Max	Unit
T	One cycle time of the master clock		12.86		ns
t_{in}	Delay of input pad		5		ns
t_{out}	Delay of output pad		5		ns
t_{su1}	Valid SDI to valid SCLK setup time	4			ns
t_{su2}	Valid CS to valid SCLK setup time	14			ns
t_{d1}	Valid SCLK to valid data delay time		10		ns
t_{d2}	CS rising edge to SDO high impedance delay time		10		ns
t_{pw1}	SCLK pulse width low	$5T + 10$			ns
t_{pw2}	SCLK pulse width high	$5T + 10$			ns
t_{h1}	Valid SDI after valid SCLK hold time	6			ns
t_{h2}	Valid CS after valid SCLK hold time (CLKE = 0/1)	5			ns
t_{T1}	Time between consecutive Read-Read or Read-Write accesses (CS rising edge to CS falling edge)	10			ns

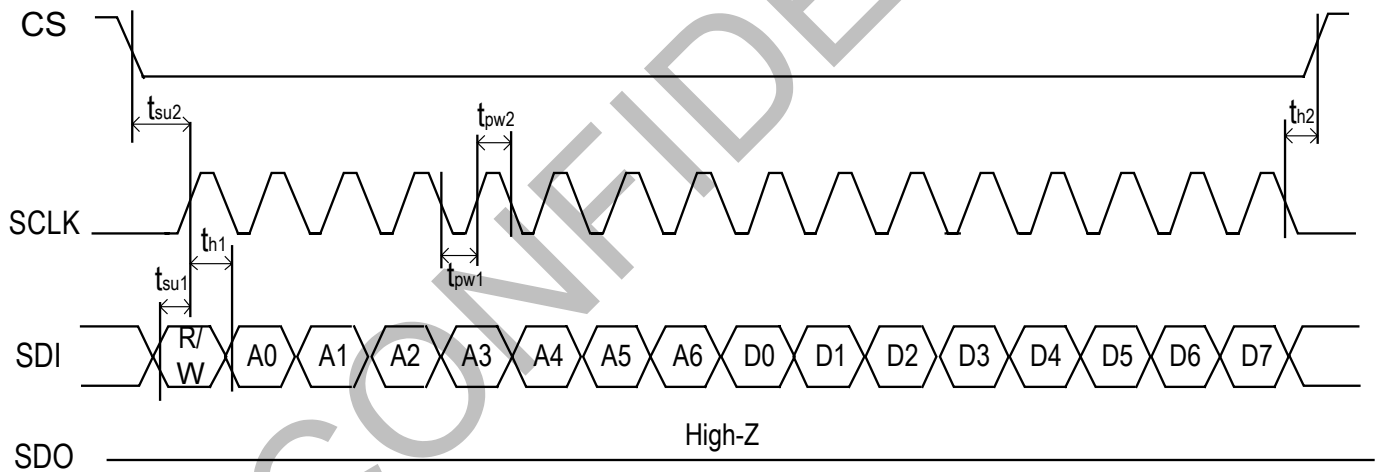

Figure 27. Serial Write Timing Diagram

Table 40: Write Timing Characteristics in Serial Mode

Symbol	Parameter	Min	Typ	Max	Unit
T	One cycle time of the master clock		12.86		ns
t _{in}	Delay of input pad		5		ns
t _{out}	Delay of output pad		5		ns
t _{su1}	Valid SDI to valid SCLK setup time	4			ns
t _{su2}	Valid CS to valid SCLK setup time	14			ns
t _{pw1}	SCLK pulse width low	5T+10			ns
t _{pw2}	SCLK pulse width high	5T+10			ns
t _{h1}	Valid SDI after valid SCLK hold time	6			ns
t _{h2}	Valid CS after valid SCLK hold time	5			ns
t _{T1}	Time between consecutive Write-Write or Write-Read accesses (CS rising edge to CS falling edge)	10			ns

6 JTAG

This device is compliant with the IEEE 1149.1 Boundary Scan standard except the following:

- The output boundary scan cells do not capture data from the core and the device does not support EXTEST instruction;
- The TRST pin is set low by default and JTAG is disabled in order to be consistent with other manufacturers.

The JTAG interface timing diagram is shown in Figure 28.

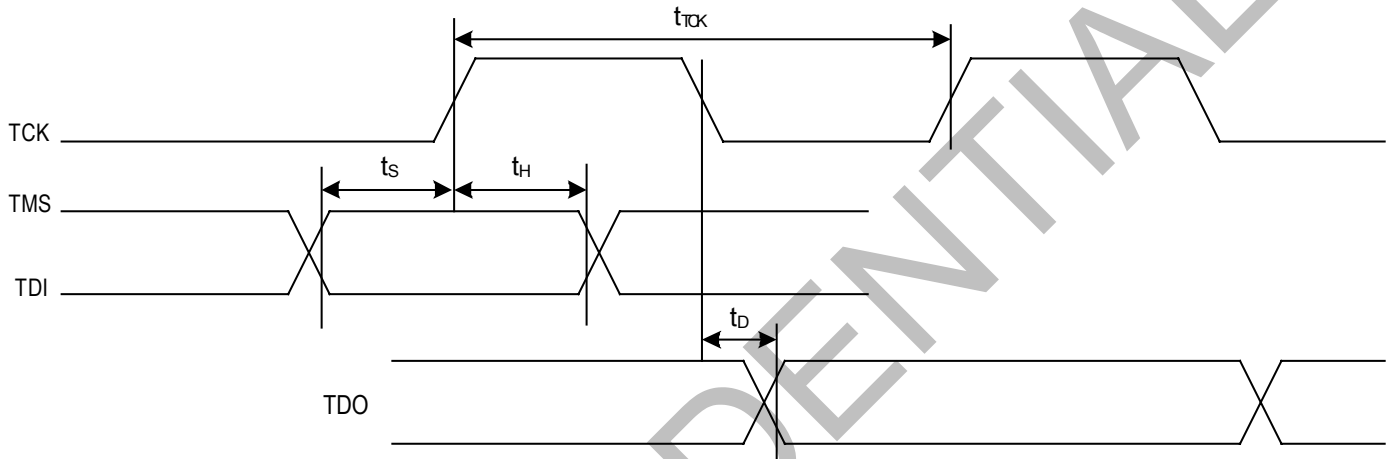

Figure 28. JTAG Interface Timing Diagram

Table 41: JTAG Timing Characteristics

Symbol	Parameter	Min	Typ	Max	Unit
t_{TCK}	TCK period	100			ns
t_s	TMS / TDI to TCK setup time	25			ns
t_H	TCK to TMS / TDI Hold Time	25			ns
t_D	TCK to TDO delay time			50	ns

7 PROGRAMMING INFORMATION

After reset, all the registers are set to their default values. The registers are read or written via the microprocessor interface.

Before any write operation, the value in register PROTECTION_CNFG is recommended to be confirmed to make sure whether the write operation is enabled. The device provides 3 register protection modes:

- Protected mode: no other registers can be written except register PROTECTION_CNFG itself;
- Fully Unprotected mode: all the writable registers can be written;
- Single Unprotected mode: one more register can be written besides register PROTECTION_CNFG. After write operation (not including writing a '1' to clear a bit to '0'), the device automatically switches to Protected mode.

Writing '0' to the registers will take no effect if the registers are cleared by writing '1'.

T0 and T4 paths share some registers, whose addresses are 27H, 28H, 2BH, 4EH, 4FH, 5AH, 5BH, 62H ~ 64H, 68H and 69H. The names of shared registers are marked with a *. Before register read/write operation, register T4_T0_REG_SEL_CNFG is recommended to be confirmed to make sure whether the register operation is available for T0 or T4 path.

The access of the Multi-word Registers is different from that of the Single-word Registers. Take the registers (04H, 05H and 06H) for an example, the write operation for the Multi-word Registers follows a fixed sequence. The register (04H) is configured first and the register (06H) is configured last. The three registers are configured continuously and should not be interrupted by any operation. The crystal calibration configuration will take effect after all the three registers are configured. During read operation, the register (04H) is read first and the register (06H) is read last. The crystal calibration reading should be continuous and not be interrupted by any operation.

Certain bit locations within the device register map are designated as Reserved. To ensure proper and predictable operation, bits designated as Reserved must be set with their default values.

7.1 REGISTER MAP

Table 42 is the map of all the registers, sorted in an ascending order of their addresses.

Table 42: Register List and Map

Address (Hex)	Register Name	Bit 7	Bit 6	Bit 5	Bit 4	Bit 3	Bit 2	Bit 1	Bit 0	Reference Page	
Global Control Registers											
00	ID[7:0] - Device ID 1	ID[7:0]									P 65
01	ID[15:8] - Device ID 2	ID[15:8]									P 66
02	MPU_PIN_STS - MPU_MODE[2:0] Pins Status	-	-	-	-	-	MPU_PIN_STS[2:0]			P 66	
04	NOMINAL_FREQ[7:0]_CNFG - Crystal Oscillator Frequency Offset Calibration Configuration 1	NOMINAL_FREQ_VALUE[7:0]									P 66
05	NOMINAL_FREQ[15:8]_CNFG - Crystal Oscillator Frequency Offset Calibration Configuration 2	NOMINAL_FREQ_VALUE[15:8]									P 67
06	NOMINAL_FREQ[23:16]_CNFG - Crystal Oscillator Frequency Offset Calibration Configuration 3	NOMINAL_FREQ_VALUE[23:16]									P 67
07	T4_T0_REG_SEL_CNFG - T0 / T4 Registers Selection Configuration	-	-	-	T4_T0_SEL	-	-	-	-	P 67	
08	PHASE_ALARM_TIME_OUT_CNFG - Phase Lock Alarm Time-Out Configuration	MULTI_FACTOR[1:0]		TIME_OUT_VALUE[5:0]						P 68	
09	INPUT_MODE_CNFG - Input Mode Configuration	AUTO_EX T_SYNC_ EN	EXT_SYN C_EN	PH_ALAR M_TIMEO UT	SYNC_FREQ[1:0]		IN_SONET _SDH	MASTER_ SLAVE	REVERTIV E_MODE	P 69	
0A	DIFFERENTIAL_IN_OUT_OSCI_CNFG - Differential Input / Output Port & Master Clock Configuration	-	-	-	-	-	OSC_EDG E	OUT5_PE CL_LVDS	OUT4_PE CL_LVDS	P 70	

Table 42: Register List and Map (Continued)

Address (Hex)	Register Name	Bit 7	Bit 6	Bit 5	Bit 4	Bit 3	Bit 2	Bit 1	Bit 0	Reference Page		
0B	MON_SW_PBO_CNFG - Frequency Monitor, Input Clock Selection & PBO Control	FREQ_MON_CLK	LOS_FLAG_TO_TDO	ULTR_FAST_SW	EXT_SW	PBO_FREQ_Z	PBO_EN	-	FREQ_MON_HARD_EN	P 71		
13	MS_SL_CTRL_CNFG - Master Slave Control	-	-	-	-	-	-	-	MS_SL_CTRL	P 72		
7E	PROTECTION_CNFG - Register Protection Mode Configuration	PROTECTION_DATA[7:0]									P 72	
7F	MPU_SEL_CNFG - Microprocessor Interface Mode Configuration	-	-	-	-	-	MPU_SEL_CNFG[2:0]			P 73		
Interrupt Registers												
0C	INTERRUPT_CNFG - Interrupt Configuration	-	-	-	-	-	-	HZ_EN	INT_POL	P 74		
0D	INTERRUPTS1_STS - Interrupt Status 1	-	-	IN[4:1]			-	-		P 74		
0E	INTERRUPTS2_STS - Interrupt Status 2	T0_OPERATING_MODE	T0_MAIN_REF_FAILED	-	-	-	IN5	-	-	P 75		
0F	INTERRUPTS3_STS - Interrupt Status 3	EX_SYNC_ALARM	T4_STS	-	INPUT_TO_T4	-	-	-	-	P 76		
10	INTERRUPTS1_ENABLE_CNFG - Interrupt Control 1	-	-	IN[4:1]			-	-		P 76		
11	INTERRUPTS2_ENABLE_CNFG - Interrupt Control 2	T0_OPERATING_MODE	T0_MAIN_REF_FAILED	-	-	-	IN5	-	-	P 77		
12	INTERRUPTS3_ENABLE_CNFG - Interrupt Control 3	EX_SYNC_ALARM	T4_STS	-	INPUT_TO_T4	-	-	-	-	P 77		
Input Clock Frequency & Priority Configuration Registers												
16	IN1_CNFG - Input Clock 1 Configuration	DIRECT_DIV	LOCK_8K	BUCKET_SEL[1:0]		IN_FREQ[3:0]				P 78		
17	IN2_CNFG - Input Clock 2 Configuration	DIRECT_DIV	LOCK_8K	BUCKET_SEL[1:0]		IN_FREQ[3:0]				P 79		
18	IN3_IN4_HF_DIV_CNFG - Input Clock 3 & 4 High Frequency Divider Configuration	IN4_DIV[1:0]		-	-	-	-	IN3_DIV[1:0]		P 80		
19	IN3_CNFG - Input Clock 3 Configuration	DIRECT_DIV	LOCK_8K	BUCKET_SEL[1:0]		IN_FREQ[3:0]				P 81		
1A	IN4_CNFG - Input Clock 4 Configuration	DIRECT_DIV	LOCK_8K	BUCKET_SEL[1:0]		IN_FREQ[3:0]				P 82		
1F	IN5_CNFG - Input Clock 5 Configuration	DIRECT_DIV	LOCK_8K	BUCKET_SEL[1:0]		IN_FREQ[3:0]				P 83		
23	PRE_DIV_CH_CNFG - DivN Divider Channel Selection	-	-	-	-	PRE_DIV_CH_VALUE[3:0]				P 84		
24	PRE_DIVN[7:0]_CNFG - DivN Divider Division Factor Configuration 1	PRE_DIVN_VALUE[7:0]									P 84	
25	PRE_DIVN[14:8]_CNFG - DivN Divider Division Factor Configuration 2	-	PRE_DIVN_VALUE[14:8]									P 85
27	IN1_IN2_SEL_PRIORITY_CNFG - Input Clock 1 & 2 Priority Configuration *	IN2_SEL_PRIORITY[3:0]			IN1_SEL_PRIORITY[3:0]						P 86	

Table 42: Register List and Map (Continued)

Address (Hex)	Register Name	Bit 7	Bit 6	Bit 5	Bit 4	Bit 3	Bit 2	Bit 1	Bit 0	Reference Page
28	IN3_IN4_SEL_PRIORITY_CNFG - Input Clock 3 & 4 Priority Configuration *	IN4_SEL_PRIORITY[3:0]				IN3_SEL_PRIORITY[3:0]				P 87
2B	IN5_SEL_PRIORITY_CNFG - Input Clock 5 Priority Configuration *	-	-	-	-	IN5_SEL_PRIORITY[3:0]				P 88
Input Clock Quality Monitoring Configuration & Status Registers										
2E	FREQ_MON_FACTOR_CNFG - Factor of Frequency Monitor Configuration	-	-	-	-	FREQ_MON_FACTOR[3:0]				P 89
2F	ALL_FREQ_MON_THRESHOLD_CNFG - Frequency Monitor Threshold for All Input Clocks Configuration	-ALL_FREQ_HARD_THRESHOLD[7:4]				ALL_FREQ_HARD_THRESHOLD[3:0]				P 90
31	UPPER_THRESHOLD_0_CNFG - Upper Threshold for Leaky Bucket Configuration 0	UPPER_THRESHOLD_0_DATA[7:0]								P 90
32	LOWER_THRESHOLD_0_CNFG - Lower Threshold for Leaky Bucket Configuration 0	LOWER_THRESHOLD_0_DATA[7:0]								P 91
33	BUCKET_SIZE_0_CNFG - Bucket Size for Leaky Bucket Configuration 0	BUCKET_SIZE_0_DATA[7:0]								P 91
34	DECAY_RATE_0_CNFG - Decay Rate for Leaky Bucket Configuration 0	-	-	-	-	-	-	DECAY_RATE_0_DATA [1:0]		P 91
35	UPPER_THRESHOLD_1_CNFG - Upper Threshold for Leaky Bucket Configuration 1	UPPER_THRESHOLD_1_DATA[7:0]								P 92
36	LOWER_THRESHOLD_1_CNFG - Lower Threshold for Leaky Bucket Configuration 1	LOWER_THRESHOLD_1_DATA[7:0]								P 92
37	BUCKET_SIZE_1_CNFG - Bucket Size for Leaky Bucket Configuration 1	BUCKET_SIZE_1_DATA[7:0]								P 92
38	DECAY_RATE_1_CNFG - Decay Rate for Leaky Bucket Configuration 1	-	-	-	-	-	-	DECAY_RATE_1_DATA [1:0]		P 93
39	UPPER_THRESHOLD_2_CNFG - Upper Threshold for Leaky Bucket Configuration 2	UPPER_THRESHOLD_2_DATA[7:0]								P 93
3A	LOWER_THRESHOLD_2_CNFG - Lower Threshold for Leaky Bucket Configuration 2	LOWER_THRESHOLD_2_DATA[7:0]								P 93
3B	BUCKET_SIZE_2_CNFG - Bucket Size for Leaky Bucket Configuration 2	BUCKET_SIZE_2_DATA[7:0]								P 94
3C	DECAY_RATE_2_CNFG - Decay Rate for Leaky Bucket Configuration 2	-	-	-	-	-	-	DECAY_RATE_2_DATA [1:0]		P 94
3D	UPPER_THRESHOLD_3_CNFG - Upper Threshold for Leaky Bucket Configuration 3	UPPER_THRESHOLD_3_DATA[7:0]								P 94
3E	LOWER_THRESHOLD_3_CNFG - Lower Threshold for Leaky Bucket Configuration 3	LOWER_THRESHOLD_3_DATA[7:0]								P 95
3F	BUCKET_SIZE_3_CNFG - Bucket Size for Leaky Bucket Configuration 3	BUCKET_SIZE_3_DATA[7:0]								P 95
40	DECAY_RATE_3_CNFG - Decay Rate for Leaky Bucket Configuration 3	-	-	-	-	-	-	DECAY_RATE_3_DATA [1:0]		P 95

Table 42: Register List and Map (Continued)

Address (Hex)	Register Name	Bit 7	Bit 6	Bit 5	Bit 4	Bit 3	Bit 2	Bit 1	Bit 0	Reference Page
41	IN_FREQ_READ_CH_CNFG - Input Clock Frequency Read Channel Selection	-	-	-	-	IN_FREQ_READ_CH[3:0]				P 96
42	IN_FREQ_READ_STS - Input Clock Frequency Read Value	IN_FREQ_VALUE[7:0]								P 96
44	IN1_IN2_STS - Input Clock 1 & 2 Status	-	IN2_FREQ_HARD_ALARM	IN2_NO_ACTIVITY_ALARM	IN2_PH_LOCK_ALARM	-	IN1_FREQ_HARD_ALARM	IN1_NO_ACTIVITY_ALARM	IN1_PH_LOCK_ALARM	P 97
45	IN3_IN4_STS - Input Clock 3 & 4 Status	-	IN4_FREQ_HARD_ALARM	IN4_NO_ACTIVITY_ALARM	IN4_PH_LOCK_ALARM	-	IN3_FREQ_HARD_ALARM	IN3_NO_ACTIVITY_ALARM	IN3_PH_LOCK_ALARM	P 98
48	IN5_STS - Input Clock 5 Status	-	-	-	-	-	IN5_FREQ_HARD_ALARM	IN5_NO_ACTIVITY_ALARM	IN5_PH_LOCK_ALARM	P 99
T0 / T4 DPLL Input Clock Selection Registers										
4A	INPUT_VALID1_STS - Input Clocks Validity 1	-	-	IN[4:1]			-	-		P 100
4B	INPUT_VALID2_STS - Input Clocks Validity 2	-	-	-	-	-	IN5	-	-	P 100
4C	REMOTE_INPUT_VALID1_CNFG - Input Clocks Validity Configuration 1	-D	-	IN4_VALID	IN3_VALID	IN2_VALID	IN1_VALID	-	-	P 100
4D	REMOTE_INPUT_VALID2_CNFG - Input Clocks Validity Configuration 2	-	-	-	-	-	IN5_VALID	-	-	P 101
4E	PRIORITY_TABLE1_STS - Priority Status 1 *	HIGHEST_PRIORITY_VALIDATED[3:0]			CURRENTLY_SELECTED_INPUT[3:0]					P 101
4F	PRIORITY_TABLE2_STS - Priority Status 2 *	THIRD_HIGHEST_PRIORITY_VALIDATED[3:0]			SECOND_HIGHEST_PRIORITY_VALIDATED[3:0]					P 102
50	T0_INPUT_SEL_CNFG - T0 Selected Input Clock Configuration	-	-	-	-	T0_INPUT_SEL[3:0]				P 103
51	T4_INPUT_SEL_CNFG - T4 Selected Input Clock Configuration	-	T4_LOCK_T0	T0_FOR_T4	T4_TEST_T0_PH	T4_INPUT_SEL[3:0]				P 104
T0 / T4 DPLL State Machine Control Registers										
52	OPERATING_STS - DPLL Operating Status	EX_SYNC_ALARM_MON	T4_DPLL_LOCK	T0_DPLL_SOFT_FREQ_ALARM	T4_DPLL_SOFT_FREQ_ALARM	T0_DPLL_LOCK	T0_DPLL_OPERATING_MODE[2:0]			P 105
53	T0_OPERATING_MODE_CNFG - T0 DPLL Operating Mode Configuration	-	-	-	-	-	T0_OPERATING_MODE[2:0]			P 106
54	T4_OPERATING_MODE_CNFG - T4 DPLL Operating Mode Configuration	-	-	-	-	-	T4_OPERATING_MODE[2:0]			P 106
T0 / T4 DPLL & APLL Configuration Registers										
55	T0_DPLL_APLL_PATH_CNFG - T0 DPLL & APLL Path Configuration	T0_APLL_PATH[3:0]			T0_GSM_OBSAI_16E1_16T1_SEL[1:0]		T0_12E1_24T1_E3_T3_SEL[1:0]			P 107
56	T0_DPLL_START_BW_DAMPING_CNFG - T0 DPLL Start Bandwidth & Damping Factor Configuration	T0_DPLL_START_DAMPING[2:0]			T0_DPLL_START_BW[4:0]					P 108
57	T0_DPLL_ACQ_BW_DAMPING_CNFG - T0 DPLL Acquisition Bandwidth & Damping Factor Configuration	T0_DPLL_ACQ_DAMPING[2:0]			T0_DPLL_ACQ_BW[4:0]					P 109

Table 42: Register List and Map (Continued)

Address (Hex)	Register Name	Bit 7	Bit 6	Bit 5	Bit 4	Bit 3	Bit 2	Bit 1	Bit 0	Reference Page	
58	T0_DPLL_LOCKED_BW_DAMPING_CNFG - T0 DPLL Locked Bandwidth & Damping Factor Configuration	T0_DPLL_LOCKED_DAMPING[2:0]			T0_DPLL_LOCKED_BW[4:0]					P 110	
59	T0_BW_OVERSHOOT_CNFG - T0 DPLL Bandwidth Overshoot Configuration	AUTO_BW_SEL	-	-	-	T0_LIMIT	-	-	-	P 111	
5A	PHASE_LOSS_COARSE_LIMIT_CNFG - Phase Loss Coarse Detector Limit Configuration *	COARSE_PH_LOS_LIMT_EN	WIDE_EN	MULTI_PH_APP	MULTI_PH_8K_4K_2K_EN	PH_LOS_COARSE_LIMIT[3:0]				P 112	
5B	PHASE_LOSS_FINE_LIMIT_CNFG - Phase Loss Fine Detector Limit Configuration *	FINE_PH_LOS_LIMT_EN	FAST_LOS_SW	-	-	-	PH_LOS_FINE_LIMIT[2:0]			P 113	
5C	T0_HOLDOVER_MODE_CNFG - T0 DPLL Holdover Mode Configuration	MAN_HOLDOVER	AUTO_AVG	FAST_AVG	READ_AVG	TEMP_HOLDOVER_MODE[1:0]		-	-	P 114	
5D	T0_HOLDOVER_FREQ[7:0]_CNFG - T0 DPLL Holdover Frequency Configuration 1	T0_HOLDOVER_FREQ[7:0]								P 114	
5E	T0_HOLDOVER_FREQ[15:8]_CNFG - T0 DPLL Holdover Frequency Configuration 2	T0_HOLDOVER_FREQ[15:8]								P 115	
5F	T0_HOLDOVER_FREQ[23:16]_CNFG - T0 DPLL Holdover Frequency Configuration 3	T0_HOLDOVER_FREQ[23:16]								P 115	
60	T4_DPLL_APLL_PATH_CNFG - T4 DPLL & APLL Path Configuration	T4_APLL_PATH[3:0]				T4_GSM_GPS_16E1_16T1_SEL[1:0]		T4_12E1_24T1_E3_T3_SEL[1:0]		P 116	
61	T4_DPLL_LOCKED_BW_DAMPING_CNFG - T4 DPLL Locked Bandwidth & Damping Factor Configuration	T4_DPLL_LOCKED_DAMPING[2:0]			-	-	-	T4_DPLL_LOCKED_BW[1:0]		P 117	
62	CURRENT_DPLL_FREQ[7:0]_STS - DPLL Current Frequency Status 1 *	CURRENT_DPLL_FREQ[7:0]								P 117	
63	CURRENT_DPLL_FREQ[15:8]_STS - DPLL Current Frequency Status 2 *	CURRENT_DPLL_FREQ[15:8]								P 117	
64	CURRENT_DPLL_FREQ[23:16]_STS - DPLL Current Frequency Status 3 *	CURRENT_DPLL_FREQ[23:16]								P 118	
65	DPLL_FREQ_SOFT_LIMIT_CNFG - DPLL Soft Limit Configuration	FREQ_LIMT_PH_LOS	DPLL_FREQ_SOFT_LIMIT[6:0]								P 118
66	DPLL_FREQ_HARD_LIMIT[7:0]_CNFG - DPLL Hard Limit Configuration 1	DPLL_FREQ_HARD_LIMIT[7:0]								P 118	
67	DPLL_FREQ_HARD_LIMIT[15:8]_CNFG - DPLL Hard Limit Configuration 2	DPLL_FREQ_HARD_LIMIT[15:8]								P 119	
68	CURRENT_DPLL_PHASE[7:0]_STS - DPLL Current Phase Status 1 *	CURRENT_PH_DATA[7:0]								P 119	
69	CURRENT_DPLL_PHASE[15:8]_STS - DPLL Current Phase Status 2 *	CURRENT_PH_DATA[15:8]								P 119	
6A	T0_T4_APLL_BW_CNFG - T0 / T4 APLL Bandwidth Configuration	-	-	T0_APLL_BW[1:0]	-	-	T4_APLL_BW[1:0]		P 120		
Output Configuration Registers											
6D	OUT1_FREQ_CNFG - Output Clock 1 Frequency Configuration	OUT1_PATH_SEL[3:0]				OUT1_DIVIDER[3:0]				P 121	

Table 42: Register List and Map (Continued)

Address (Hex)	Register Name	Bit 7	Bit 6	Bit 5	Bit 4	Bit 3	Bit 2	Bit 1	Bit 0	Reference Page
6E	OUT2_FREQ_CNFG - Output Clock 2 Frequency Configuration	OUT2_PATH_SEL[3:0]			OUT2_DIVIDER[3:0]					P 122
6F	OUT3_FREQ_CNFG - Output Clock 3 Frequency Configuration	OUT3_PATH_SEL[3:0]			OUT3_DIVIDER[3:0]					P 123
70	OUT4_FREQ_CNFG - Output Clock 4 Frequency Configuration	OUT4_PATH_SEL[3:0]			OUT4_DIVIDER[3:0]					P 124
71	OUT5_FREQ_CNFG - Output Clock 5 Frequency Configuration	OUT5_PATH_SEL[3:0]			OUT5_DIVIDER[3:0]					P 125
72	OUTPUT_INV2 - Output Clock 4 & 5 Invert Configuration	-						OUT5_INV	OUT4_INV	P 121
73	OUTPUT_INV1 - Output Clock 1 ~ 3 Invert Configuration	-			OUT3_INV	OUT2_INV	OUT1_INV	-		P 122
74	FR_MFR_SYNC_CNFG - Frame Sync & Multiframe Sync Output Configuration	IN_2K_4K_8K_INV	8K_EN	2K_EN	2K_8K_PUL_POSITON	8K_INV	8K_PUL	2K_INV	2K_PUL	P 127
PBO & Phase Offset Control Registers										
78	PHASE_MON_PBO_CNFG - Phase Transient Monitor & PBO Configuration	IN_NOISE_WINDOW	-	PH_MON_EN	PH_MON_PBO_EN	PH_TR_MON_LIMT[3:0]				P 128
7A	PHASE_OFFSET[7:0]_CNFG - Phase Offset Configuration 1	PH_OFFSET[7:0]								P 128
7B	PHASE_OFFSET[9:8]_CNFG - Phase Offset Configuration 2	PH_OFFSET_EN	-	-	-	-	-	PH_OFFSET[9:8]		P 129
Synchronization Configuration Registers										
7C	SYNC_MONITOR_CNFG - Sync Monitor Configuration	-	SYNC_MON_LIMT[2:0]			-	-	-	-	P 130
7D	SYNC_PHASE_CNFG - Sync Phase Configuration	-	-	-	-	-	-	SYNC_PH1[1:0]		P 130

7.2 REGISTER DESCRIPTION

7.2.1 GLOBAL CONTROL REGISTERS

ID[7:0] - Device ID 1

Address: 00H							
Type: Read							
Default Value: 10010000							
7	6	5	4	3	2	1	0
ID7	ID6	ID5	ID4	ID3	ID2	ID1	ID0
Bit	Name	Description					
7 - 0	ID[7:0]	Refer to the description of the ID[15:8] bits (b7~0, 01H).					

ID[15:8] - Device ID 2

Address: 01H							
Type: Read							
Default Value: 00110011							
7	6	5	4	3	2	1	0
ID15	ID14	ID13	ID12	ID11	ID10	ID9	ID8
Bit	Name	Description					
7 - 0	ID[15:8]	The value in the ID[15:0] bits are pre-set, representing the identification number for the IDT82V3389.					

MPU_PIN_STS - MPU_MODE[2:0] Pins Status

Address: 02H							
Type: Read							
Default Value: XXXXXXXX							
7	6	5	4	3	2	1	0
-	-	-	-	-	MPU_PIN_STS2	MPU_PIN_STS1	MPU_PIN_STS0
Bit	Name	Description					
7 - 3	-	Reserved.					
2 - 0	MPU_PIN_STS[2:0]	These bits indicate the value of the MPU_MODE[2:0] pins. The default value of these bits is determined by the MPU_MODE[2:0] pins during reset.					

NOMINAL_FREQ[7:0]_CNFG - Crystal Oscillator Frequency Offset Calibration Configuration 1

Address: 04H							
Type: Read / Write							
Default Value: 00000000							
7	6	5	4	3	2	1	0
NOMINAL_FRE Q_VALUE7	NOMINAL_FRE Q_VALUE6	NOMINAL_FRE Q_VALUE5	NOMINAL_FRE Q_VALUE4	NOMINAL_FRE Q_VALUE3	NOMINAL_FRE Q_VALUE2	NOMINAL_FRE Q_VALUE1	NOMINAL_FRE Q_VALUE0
Bit	Name	Description					
7 - 0	NOMINAL_FREQ_VALUE[7:0]	Refer to the description of the NOMINAL_FREQ_VALUE[23:16] bits (b7~0, 06H).					

NOMINAL_FREQ[15:8]_CNFG - Crystal Oscillator Frequency Offset Calibration Configuration 2

Address: 05H							
Type: Read / Write							
Default Value: 00000000							
7	6	5	4	3	2	1	0
NOMINAL_FREQ_VALUE15	NOMINAL_FREQ_VALUE14	NOMINAL_FREQ_VALUE13	NOMINAL_FREQ_VALUE12	NOMINAL_FREQ_VALUE11	NOMINAL_FREQ_VALUE10	NOMINAL_FREQ_VALUE9	NOMINAL_FREQ_VALUE8
Bit	Name	Description					
7 - 0	NOMINAL_FREQ_VALUE[15:8]	Refer to the description of the NOMINAL_FREQ_VALUE[23:16] bits (b7-0, 06H).					

NOMINAL_FREQ[23:16]_CNFG - Crystal Oscillator Frequency Offset Calibration Configuration 3

Address: 06H							
Type: Read / Write							
Default Value: 00000000							
7	6	5	4	3	2	1	0
NOMINAL_FREQ_VALUE23	NOMINAL_FREQ_VALUE22	NOMINAL_FREQ_VALUE21	NOMINAL_FREQ_VALUE20	NOMINAL_FREQ_VALUE19	NOMINAL_FREQ_VALUE18	NOMINAL_FREQ_VALUE17	NOMINAL_FREQ_VALUE16
Bit	Name	Description					
7 - 0	NOMINAL_FREQ_VALUE[23:16]	<p>The NOMINAL_FREQ_VALUE[23:0] bits represent a 2's complement signed integer. If the value is multiplied by 0.0000884, the calibration value for the master clock in ppm will be gotten.</p> <p>For example, the frequency offset on OSC1 is +3 ppm. Though -3 ppm should be compensated, the calibration value is calculated as +3 ppm:</p> <p>$3 \div 0.0000884 = 33937$ (Dec.) = 8490 (Hex);</p> <p>So '008490' should be written into these bits.</p> <p>The calibration range is within ± 741 ppm.</p>					

T4_T0_REG_SEL_CNFG - T0 / T4 Registers Selection Configuration

Address: 07H							
Type: Read / Write							
Default Value: XXX0XXXX							
7	6	5	4	3	2	1	0
-	-	-	T4_T0_SEL	-	-	-	-
Bit	Name	Description					
7 - 5	-	Reserved.					
4	T4_T0_SEL	<p>A part of the registers are shared by T0 and T4 paths. These registers are addressed 27H, 28H, 2BH, 4EH, 4FH, 5AH, 5BH, 62H ~ 64H, 68H and 69H. This bit determines whether the register configuration is available for T0 or T4 path.</p> <p>0: T0 path (default).</p> <p>1: T4 path.</p>					
3 - 0	-	Reserved.					

PHASE_ALARM_TIME_OUT_CNFG - Phase Lock Alarm Time-Out Configuration

Address: 08H							
Type: Read / Write							
Default Value: 00110010							
7	6	5	4	3	2	1	0
MULTI_FACTO R1	MULTI_FACTO R0	TIME_OUT_VA LUE5	TIME_OUT_VA LUE4	TIME_OUT_VA LUE3	TIME_OUT_VA LUE2	TIME_OUT_VA LUE1	TIME_OUT_VAL UE0
Bit	Name	Description					
7 - 6	MULTI_FACTOR[1:0]	<p>These bits determine a factor which has a relationship with a period in seconds. A phase lock alarm will be raised if the T0 selected input clock is not locked in T0 DPLL within this period. If the PH_ALARM_TIMEOUT bit (b5, 09H) is '1', the phase lock alarm will be cleared after this period (starting from when the alarm is raised). Refer to the description of the TIME_OUT_VALUE[5:0] bits (b5~0, 08H).</p> <p>00: 2 (default) 01: 4 10: 8 11: 16</p>					
5 - 0	TIME_OUT_VALUE[5:0]	<p>These bits represent an unsigned integer. If the value in these bits is multiplied by the value in the MULTI_FACTOR[1:0] bits (b7~6, 08H), a period in seconds will be gotten.</p> <p>A phase lock alarm will be raised if the T0 selected input clock is not locked in T0 DPLL within this period. If the PH_ALARM_TIMEOUT bit (b5, 09H) is '1', the phase lock alarm will be cleared after this period (starting from when the alarm is raised).</p>					

INPUT_MODE_CNFG - Input Mode Configuration

Address: 09H																			
Type: Read / Write																			
Default Value: 10100XX0																			
7	6	5	4	3	2	1	0												
AUTO_EXT_SYNC_EN	EXT_SYNC_EN	PH_ALARM_TIMEOUT	SYNC_FREQ1	SYNC_FREQ0	IN_SONET_SDH	MASTER_SLAVE	REVERTIVE_MODE												
Bit	Name	Description																	
7	AUTO_EXT_SYNC_EN	Refer to the description of the EXT_SYNC_EN bit (b6, 09H).																	
6	EXT_SYNC_EN	<p>This bit, together with the AUTO_EXT_SYNC_EN bit (b7, 09H), determines whether EX_SYNC1 is enabled to synchronize the frame sync output signals.</p> <table border="1" style="width: 100%; border-collapse: collapse;"> <thead> <tr> <th>AUTO_EXT_SYNC_EN</th> <th>EXT_SYNC_EN</th> <th>Synchronization</th> </tr> </thead> <tbody> <tr> <td style="text-align: center;">don't-care</td> <td style="text-align: center;">0</td> <td style="text-align: center;">Disabled (default)</td> </tr> <tr> <td style="text-align: center;">0</td> <td style="text-align: center;">1</td> <td style="text-align: center;">Enabled</td> </tr> <tr> <td style="text-align: center;">1</td> <td style="text-align: center;">1</td> <td style="text-align: center;">Enabled if the T0 selected input clock is IN5; otherwise, disabled.</td> </tr> </tbody> </table>						AUTO_EXT_SYNC_EN	EXT_SYNC_EN	Synchronization	don't-care	0	Disabled (default)	0	1	Enabled	1	1	Enabled if the T0 selected input clock is IN5; otherwise, disabled.
AUTO_EXT_SYNC_EN	EXT_SYNC_EN	Synchronization																	
don't-care	0	Disabled (default)																	
0	1	Enabled																	
1	1	Enabled if the T0 selected input clock is IN5; otherwise, disabled.																	
5	PH_ALARM_TIMEOUT	<p>This bit determines how to clear the phase lock alarm.</p> <p>0: The phase lock alarm will be cleared when a '1' is written to the corresponding INn_PH_LOCK_ALARM bit (b4/0, 44H & 45H & 48H).</p> <p>1: The phase lock alarm will be cleared after a period (= $TIME_OUT_VALUE[5:0] (b5-0, 08H) \times MULTI_FACTOR[1:0] (b7-6, 08H)$ in seconds) which starts from when the alarm is raised. (default)</p>																	
4 - 3	SYNC_FREQ[1:0]	<p>These bits set the frequency of the frame sync signal input on the EX_SYNC1 pin.</p> <p>00: 8 kHz (default)</p> <p>01: 8 kHz.</p> <p>10: 4 kHz.</p> <p>11: 2 kHz.</p>																	
2	IN_SONET_SDH	<p>This bit selects the SDH or SONET network type.</p> <p>0: SDH. The DPLL required clock is 2.048 MHz when the IN_FREQ[3:0] bits (b3-0, 16H & 17H & 19H) are '0001'; the T0/T4 DPLL output from the 16E1/16T1 path is 16E1.</p> <p>1: SONET. The DPLL required clock is 1.544 MHz when the IN_FREQ[3:0] bits (b3-0, 16H & 17H & 19H) are '0001'; the T0/T4 DPLL output from the 16E1/16T1 path is 16T1.</p> <p>The default value of this bit is determined by the SONET/SDH pin during reset.</p>																	
1	MASTER_SLAVE	<p>This bit is read only. It indicates the value of the MS/SL pin.</p> <p>Its default value is determined by the MS/SL pin during reset.</p>																	
0	REVERTIVE_MODE	<p>This bit selects Revertive or Non-Revertive switch for T0 path.</p> <p>0: Non-Revertive switch. (default)</p> <p>1: Revertive switch.</p>																	

DIFFERENTIAL_IN_OUT_OSCI_CNFG - Differential Input / Output Port & Master Clock Configuration

Address: 0AH							
Type: Read / Write							
Default Value: XXXXX001							
7	6	5	4	3	2	1	0
-	-	-	-	-	OSC_EDGE	OUT5_PECL_LVDS	OUT4_PECL_LVDS
Bit	Name	Description					
7 - 3	-	Reserved.					
2	OSC_EDGE	This bit selects a better active edge of the master clock. 0: The rising edge. (default) 1: The falling edge.					
1	OUT5_PECL_LVDS	This bit selects a port technology for OUT5. 0: LVDS. (default) 1: PECL.					
0	OUT4_PECL_LVDS	This bit selects a port technology for OUT4. 0: LVDS. 1: PECL. (default)					

MON_SW_PBO_CNFG - Frequency Monitor, Input Clock Selection & PBO Control

Address: 0BH							
Type: Read / Write							
Default Value: 100X01X1							
7	6	5	4	3	2	1	0
FREQ_MON_CLK	LOS_FLAG_TO_TDO	ULTR_FAST_SW	EXT_SW	PBO_FREZ	PBO_EN	-	FREQ_MON_HARD_EN
Bit	Name	Description					
7	FREQ_MON_CLK	The bit selects a reference clock for input clock frequency monitoring. 0: The output of T0 DPLL. 1: The master clock. (default)					
6	LOS_FLAG_TO_TDO	The bit determines whether the interrupt of T0 selected input clock fail - is reported by the TDO pin. 0: Not reported. TDO pin is used as JTAG test data output which complies with IEEE 1149.1. (default) 1: Reported. TDO pin mimics the state of the T0_MAIN_REF_FAILED bit (b6, 0EH) and does not strictly comply with IEEE 1149.1.					
5	ULTR_FAST_SW	This bit determines whether the T0 selected input clock is valid when missing 2 consecutive clock cycles or more. 0: Valid. (default) 1: Invalid.					
4	EXT_SW	This bit determines the T0 input clock selection. 0: Forced selection or Automatic selection, as controlled by the T0_INPUT_SEL[3:0] bits (b3~0, 50H). 1: External Fast selection. The default value of this bit is determined by the FF_SRCSW pin during reset.					
3	PBO_FREZ	This bit is valid only when the PBO is enabled by the PBO_EN bit (b2, 0BH). It determines whether PBO is frozen at the current phase offset when a PBO event is triggered. 0: Not frozen. (default) 1: Frozen. Further PBO events are ignored and the current phase offset is maintained.					
2	PBO_EN	This bit determines whether PBO is enabled when the T0 selected input clock switch or the T0 DPLL exiting from Holdover mode or Free-Run mode occurs. 0: Disabled. 1: Enabled. (default)					
1	-	Reserved.					
0	FREQ_MON_HARD_EN	This bit determines whether the frequency hard alarm is enabled when the frequency of the input clock with respect to the reference clock is above the frequency hard alarm threshold. The reference clock can be the output of T0 DPLL or the master clock, as determined by the FREQ_MON_CLK bit (b7, 0BH). 0: Disabled. 1: Enabled. (default)					

MS_SL_CTRL_CNFG - Master Slave Control

Address: 13H Type: Read / Write Default Value: XXXXXXX0																						
7	6	5	4	3	2	1	0															
-	-	-	-	-	-	-	MS_SL_CTRL															
Bit	Name	Description																				
7 - 1	-	Reserved.																				
0	MS_SL_CTRL	<p>This bit, together with the MS/SL pin, controls whether the device is configured as the Master or as the Slave.</p> <table border="1"> <thead> <tr> <th colspan="2">Master/Slave Control</th> <th rowspan="2">Result</th> </tr> <tr> <th>MS/SL pin</th> <th>MS_SL_CTRL Bit</th> </tr> </thead> <tbody> <tr> <td rowspan="2">High</td> <td>0</td> <td>Master</td> </tr> <tr> <td>1</td> <td>Slave</td> </tr> <tr> <td rowspan="2">Low</td> <td>0</td> <td>Slave</td> </tr> <tr> <td>1</td> <td>Master</td> </tr> </tbody> </table> <p>The default value of this bit is '0'.</p>						Master/Slave Control		Result	MS/SL pin	MS_SL_CTRL Bit	High	0	Master	1	Slave	Low	0	Slave	1	Master
Master/Slave Control		Result																				
MS/SL pin	MS_SL_CTRL Bit																					
High	0	Master																				
	1	Slave																				
Low	0	Slave																				
	1	Master																				

PROTECTION_CNFG - Register Protection Mode Configuration

Address: 7EH Type: Read / Write Default Value: 10000101							
7	6	5	4	3	2	1	0
PROTECTION_DATA7	PROTECTION_DATA6	PROTECTION_DATA5	PROTECTION_DATA4	PROTECTION_DATA3	PROTECTION_DATA2	PROTECTION_DATA1	PROTECTION_DATA0
Bit	Name	Description					
7 - 0	PROTECTION_DATA[7:0]	<p>These bits select a register write protection mode.</p> <p>00000000 - 10000100, 10000111 - 11111111: Protected mode. No other registers can be written except this register.</p> <p>10000101: Fully Unprotected mode. All the writable registers can be written. (default)</p> <p>10000110: Single Unprotected mode. One more register can be written besides this register. After write operation (not including writing a '1' to clear the bit to '0'), the device automatically switches to Protected mode.</p>					

MPU_SEL_CNFG - Microprocessor Interface Mode Configuration

Address: 7FH
 Type: Read / Write
 Default Value: XXXXXXXX

7	6	5	4	3	2	1	0
-	-	-	-	-	MPU_SEL_CNFG2	MPU_SEL_CNFG1	MPU_SEL_CNFG0

Bit	Name	Description
7 - 3	-	Reserved.
2 - 0	MPU_SEL_CNFG[2:0]	These bits select a microprocessor interface mode: 000: Reserved. 001: EPROM mode. 010: Multiplexed mode. 011: Intel mode. 100: Motorola mode. 101: Serial mode. 110, 111: Reserved. The default value of these bits are determined by the MPU_MODE[2:0] pins during reset.

7.2.2 INTERRUPT REGISTERS

INTERRUPT_CNFG - Interrupt Configuration

Address: 0CH							
Type: Read / Write							
Default Value: XXXXXX10							
7	6	5	4	3	2	1	0
-	-	-	-	-	-	HZ_EN	INT_POL
Bit	Name	Description					
7 - 2	-	Reserved.					
1	HZ_EN	This bit determines the output characteristics of the INT_REQ pin. 0: The output on the INT_REQ pin is high/low when the interrupt is active; the output is the opposite when the interrupt is inactive. 1: The output on the INT_REQ pin is high/low when the interrupt is active; the output is in high impedance state when the interrupt is inactive. (default)					
0	INT_POL	This bit determines the active level on the INT_REQ pin for an active interrupt indication. 0: Active low. (default) 1: Active high.					

INTERRUPTS1_STS - Interrupt Status 1

Address: 0DH							
Type: Read / Write							
Default Value: 11111111							
7	6	5	4	3	2	1	0
-	-	IN4	IN3	IN2	IN1	-	-
Bit	Name	Description					
7 - 6	-	Reserved.					
5 - 2	INn	This bit indicates the validity changes (from 'valid' to 'invalid' or from 'invalid' to 'valid') for the corresponding INn; i.e., whether there is a transition (from '0' to '1' or from '1' to '0') on the corresponding INn bit (b5~2, 4AH). Here n is any one of 4 to 1. 0: Has not changed. 1: Has changed. (default) This bit is cleared by writing a '1'.					
1 - 0	-	Reserved.					

INTERRUPTS2_STS - Interrupt Status 2

Address: 0EH
 Type: Read / Write
 Default Value: 00111111

7	6	5	4	3	2	1	0
T0_OPERATING_MODE	T0_MAIN_REF_FAILED	-	-	-	IN5	-	-

Bit	Name	Description
7	T0_OPERATING_MODE	This bit indicates the operating mode switch for T0 DPLL; i.e., whether the value in the T0_DPLL_OPERATING_MODE[2:0] bits (b2~0, 52H) changes. 0: Has not switched. (default) 1: Has switched. This bit is cleared by writing a '1'.
6	T0_MAIN_REF_FAILED	This bit indicates whether the T0 selected input clock has failed. The T0 selected input clock fails when its validity changes from 'valid' to 'invalid'; i.e., when there is a transition from '1' to '0' on the corresponding INn bit (4AH, 4BH). 0: Has not failed. (default) 1: Has failed. This bit is cleared by writing a '1'.
5 - 3	-	Reserved.
2	IN5	This bit indicates the validity changes (from 'valid' to 'invalid' or from 'invalid' to 'valid') for IN5 for T0 path, i.e., whether there is a transition (from '0' to '1' or from '1' to '0') on IN5 bit (b2, 4BH). 0: Has not changed. 1: Has changed. (default) This bit is cleared by writing a '1'.
1 - 0	-	Reserved.

INTERRUPTS3_STS - Interrupt Status 3

Address: 0FH							
Type: Read / Write							
Default Value: 11X10000							
7	6	5	4	3	2	1	0
EX_SYNC_ALARM	T4_STS	-	INPUT_TO_T4	-	-	-	-
Bit	Name	Description					
7	EX_SYNC_ALARM	This bit indicates whether an external sync alarm is raised; i.e., whether there is a transition from '0' to '1' on the EX_SYNC_ALARM_MON bit (b7, 52H). 0: Not raised. 1: Raised. (default) This bit is cleared by writing a '1'.					
6	T4_STS	This bit indicates the T4 DPLL locking status changes (from 'locked' to 'unlocked' or from 'unlocked' to 'locked'); i.e., whether there is a transition (from '0' to '1' or from '1' to '0') on the T4_DPLL_LOCK bit (b6, 52H). 0: Has not changed. 1: Has changed. (default) This bit is cleared by writing a '1'.					
5	-	Reserved.					
4	INPUT_TO_T4	This bit indicates whether all the input clocks for T4 path change to be unqualified; i.e., whether the HIGHEST_PRIORITY_VALIDATED[3:0] bits (b7~4, 4EH) are set to '0000' when these bits are available for T4 path. 0: Has not changed. 1: Has changed. (default) This bit is cleared by writing a '1'.					
3-0	-	Reserved.					

INTERRUPTS1_ENABLE_CNFG - Interrupt Control 1

Address: 10H							
Type: Read / Write							
Default Value: 00000000							
7	6	5	4	3	2	1	0
-	-	IN4	IN3	IN2	IN1	-	-
Bit	Name	Description					
7-6	-	Reserved.					
5-2	INn	This bit controls whether the interrupt is enabled to be reported on the INT_REQ pin when the input clock validity changes (from 'valid' to 'invalid' or from 'invalid' to 'valid'), i.e., when the corresponding INn bit (b5~2, 0DH) is '1'. Here n is any one of 4 to 1. 0: Disabled. (default) 1: Enabled.					
0-1	-	Reserved					

INTERRUPTS2_ENABLE_CNFG - Interrupt Control 2

Address: 11H							
Type: Read / Write							
Default Value: 00000000							
7	6	5	4	3	2	1	0
T0_OPERATING_MODE	T0_MAIN_REF_FAILED	-	-	-	IN5	-	-
Bit	Name	Description					
7	T0_OPERATING_MODE	This bit controls whether the interrupt is enabled to be reported on the INT_REQ pin when the T0 DPLL operating mode switches, i.e., when the T0_OPERATING_MODE bit (b7, 0EH) is '1'. 0: Disabled. (default) 1: Enabled.					
6	T0_MAIN_REF_FAILED	This bit controls whether the interrupt is enabled to be reported on the INT_REQ pin when the T0 selected input clock has failed; i.e., when the T0_MAIN_REF_FAILED bit (b6, 0EH) is '1'. 0: Disabled. (default) 1: Enabled.					
5 - 3	-	Reserved.					
2	IN5	This bit controls whether the interrupt is enabled to be reported on the INT_REQ pin when the input clock validity changes (from 'valid' to 'invalid' or from 'invalid' to 'valid'), i.e., when IN5 bit (b2, 0EH) is '1'. 0: Disabled. (default) 1: Enabled.					
1 - 0	-	Reserved.					

INTERRUPTS3_ENABLE_CNFG - Interrupt Control 3

Address: 12H							
Type: Read / Write							
Default Value: 00X00000							
7	6	5	4	3	2	1	0
EX_SYNC_ALARM	T4_STS	-	INPUT_TO_T4	-	-	-	-
Bit	Name	Description					
7	EX_SYNC_ALARM	This bit controls whether the interrupt is enabled to be reported on the INT_REQ pin when an external sync alarm has occurred, i.e., when the EX_SYNC_ALARM bit (b7, 0FH) is '1'. 0: Disabled. (default) 1: Enabled.					
6	T4_STS	This bit controls whether the interrupt is enabled to be reported on the INT_REQ pin when the T4 DPLL locking status changes (from 'locked' to 'unlocked' or from 'unlocked' to 'locked'), i.e., when the T4_STS bit (b6, 0FH) is '1'. 0: Disabled. (default) 1: Enabled.					
5	-	Reserved.					
4	INPUT_TO_T4	This bit controls whether the interrupt is enabled to be reported on the INT_REQ pin when all the input clocks for T4 path become unqualified, i.e., when the INPUT_TO_T4 bit (b4, 0FH) is '1'. 0: Disabled. (default) 1: Enabled.					
3 - 0	-	Reserved.					

7.2.3 INPUT CLOCK FREQUENCY & PRIORITY CONFIGURATION REGISTERS

IN1_CNFG - Input Clock 1 Configuration

Address: 16H							
Type: Read / Write							
Default Value: 00000000							
7	6	5	4	3	2	1	0
DIRECT_DIV	LOCK_8K	BUCKET_SEL1	BUCKET_SEL0	IN_FREQ3	IN_FREQ2	IN_FREQ1	IN_FREQ0
Bit	Name	Description					
7	DIRECT_DIV	Refer to the description of the LOCK_8K bit (b6, 16H).					
6	LOCK_8K	This bit, together with the DIRECT_DIV bit (b7, 16H), determines whether the DivN Divider or the Lock 8k Divider is used for IN1:					
		DIRECT_DIV bit	LOCK_8K bit	Used Divider			
		0	0	Both bypassed (default)			
		0	1	Lock 8k Divider			
		1	0	DivN Divider			
1	1	Reserved					
5 - 4	BUCKET_SEL[1:0]	These bits select one of the four groups of leaky bucket configuration registers for IN1: 00: Group 0; the addresses of the configuration registers are 31H ~ 34H. (default) 01: Group 1; the addresses of the configuration registers are 35H ~ 38H. 10: Group 2; the addresses of the configuration registers are 39H ~ 3CH. 11: Group 3; the addresses of the configuration registers are 3DH ~ 40H.					
3 - 0	IN_FREQ[3:0]	These bits set the DPLL required frequency for IN1: 0000: 8 kHz. (default) 0001: 1.544 MHz (when the IN_SONET_SDH bit (b2, 09H) is '1') / 2.048 MHz (when the IN_SONET_SDH bit (b2, 09H) is '0'). 0010: 6.48 MHz. 0011: 19.44 MHz. 0100: 25.92 MHz. 0101: 38.88 MHz. 0110 ~ 1000: Reserved. 1001: 2 kHz. 1010: 4 kHz. 1011 ~ 1111: Reserved. For IN1, the required frequency should not be set higher than frequency of the input clock.					

IN2_CNFG - Input Clock 2 Configuration

Address: 17H																						
Type: Read / Write																						
Default Value: 00000000																						
7	6	5	4	3	2	1	0															
DIRECT_DIV	LOCK_8K	BUCKET_SEL1	BUCKET_SEL0	IN_FREQ3	IN_FREQ2	IN_FREQ1	IN_FREQ0															
Bit	Name	Description																				
7	DIRECT_DIV	Refer to the description of the LOCK_8K bit (b6, 17H).																				
6	LOCK_8K	<p>This bit, together with the DIRECT_DIV bit (b7, 17H), determines whether the DivN Divider or the Lock 8k Divider is used for IN2:</p> <table border="1" style="margin-left: 20px;"> <thead> <tr> <th>DIRECT_DIV bit</th> <th>LOCK_8K bit</th> <th>Used Divider</th> </tr> </thead> <tbody> <tr> <td style="text-align: center;">0</td> <td style="text-align: center;">0</td> <td style="text-align: center;">Both bypassed (default)</td> </tr> <tr> <td style="text-align: center;">0</td> <td style="text-align: center;">1</td> <td style="text-align: center;">Lock 8k Divider</td> </tr> <tr> <td style="text-align: center;">1</td> <td style="text-align: center;">0</td> <td style="text-align: center;">DivN Divider</td> </tr> <tr> <td style="text-align: center;">1</td> <td style="text-align: center;">1</td> <td style="text-align: center;">Reserved</td> </tr> </tbody> </table>						DIRECT_DIV bit	LOCK_8K bit	Used Divider	0	0	Both bypassed (default)	0	1	Lock 8k Divider	1	0	DivN Divider	1	1	Reserved
DIRECT_DIV bit	LOCK_8K bit	Used Divider																				
0	0	Both bypassed (default)																				
0	1	Lock 8k Divider																				
1	0	DivN Divider																				
1	1	Reserved																				
5 - 4	BUCKET_SEL[1:0]	<p>These bits select one of the four groups of leaky bucket configuration registers for IN2:</p> <p>00: Group 0; the addresses of the configuration registers are 31H ~ 34H. (default)</p> <p>01: Group 1; the addresses of the configuration registers are 35H ~ 38H.</p> <p>10: Group 2; the addresses of the configuration registers are 39H ~ 3CH.</p> <p>11: Group 3; the addresses of the configuration registers are 3DH ~ 40H.</p>																				
3 - 0	IN_FREQ[3:0]	<p>These bits set the DPLL required frequency for IN2</p> <p>0000: 8 kHz. (default)</p> <p>0001: 1.544 MHz (when the IN_SONET_SDH bit (b2, 09H) is '1') / 2.048 MHz (when the IN_SONET_SDH bit (b2, 09H) is '0').</p> <p>0010: 6.48 MHz.</p> <p>0011: 19.44 MHz.</p> <p>0100: 25.92 MHz.</p> <p>0101: 38.88 MHz.</p> <p>0110 ~ 1000: Reserved.</p> <p>1001: 2 kHz.</p> <p>1010: 4 kHz.</p> <p>1011 ~ 1111: Reserved.</p> <p>For the IN2, the required frequency should not be set higher than frequency of the input clock.</p>																				

IN3_IN4_HF_DIV_CNFG - Input Clock 3 & 4 High Frequency Divider Configuration

Address: 18H							
Type: Read / Write							
Default Value: 00XXXX00							
7	6	5	4	3	2	1	0
IN4_DIV1	IN4_DIV0	-	-	-	-	IN3_DIV1	IN3_DIV0
Bit	Name	Description					
7 - 6	IN4_DIV[1:0]	These bits determine whether the HF Divider is used and what the division factor is for IN4 frequency division: 00: Bypassed. (default) 01: Divided by 4. 10: Divided by 5. 11: Reserved.					
5 - 2	-	Reserved.					
1 - 0	IN3_DIV[1:0]	These bits determine whether the HF Divider is used and what the division factor is for IN3 frequency division: 00: Bypassed. (default) 01: Divided by 4. 10: Divided by 5. 11: Reserved.					

IN3_CNFG - Input Clock 3 Configuration

Address: 19H																						
Type: Read / Write																						
Default Value: 00000011																						
7	6	5	4	3	2	1	0															
DIRECT_DIV	LOCK_8K	BUCKET_SEL1	BUCKET_SEL0	IN_FREQ3	IN_FREQ2	IN_FREQ1	IN_FREQ0															
Bit	Name	Description																				
7	DIRECT_DIV	Refer to the description of the LOCK_8K bit (b6, 19H).																				
6	LOCK_8K	<p>This bit, together with the DIRECT_DIV bit (b7, 19H), determines whether the DivN Divider or the Lock 8k Divider is used for IN3:</p> <table border="1" style="width: 100%; border-collapse: collapse;"> <thead> <tr> <th>DIRECT_DIV bit</th> <th>LOCK_8K bit</th> <th>Used Divider</th> </tr> </thead> <tbody> <tr> <td style="text-align: center;">0</td> <td style="text-align: center;">0</td> <td style="text-align: center;">Both bypassed (default)</td> </tr> <tr> <td style="text-align: center;">0</td> <td style="text-align: center;">1</td> <td style="text-align: center;">Lock 8k Divider</td> </tr> <tr> <td style="text-align: center;">1</td> <td style="text-align: center;">0</td> <td style="text-align: center;">DivN Divider</td> </tr> <tr> <td style="text-align: center;">1</td> <td style="text-align: center;">1</td> <td style="text-align: center;">Reserved</td> </tr> </tbody> </table>						DIRECT_DIV bit	LOCK_8K bit	Used Divider	0	0	Both bypassed (default)	0	1	Lock 8k Divider	1	0	DivN Divider	1	1	Reserved
DIRECT_DIV bit	LOCK_8K bit	Used Divider																				
0	0	Both bypassed (default)																				
0	1	Lock 8k Divider																				
1	0	DivN Divider																				
1	1	Reserved																				
5 - 4	BUCKET_SEL[1:0]	<p>These bits select one of the four groups of leaky bucket configuration registers for IN3:</p> <p>00: Group 0; the addresses of the configuration registers are 31H ~ 34H. (default)</p> <p>01: Group 1; the addresses of the configuration registers are 35H ~ 38H.</p> <p>10: Group 2; the addresses of the configuration registers are 39H ~ 3CH.</p> <p>11: Group 3; the addresses of the configuration registers are 3DH ~ 40H.</p>																				
3 - 0	IN_FREQ[3:0]	<p>These bits set the DPLL required frequency for IN3:</p> <p>0000: 8 kHz.</p> <p>0001: 1.544 MHz (when the IN_SONET_SDH bit (b2, 09H) is '1') / 2.048 MHz (when the IN_SONET_SDH bit (b2, 09H) is '0').</p> <p>0010: 6.48 MHz.</p> <p>0011: 19.44 MHz. (default)</p> <p>0100: 25.92 MHz.</p> <p>0101: 38.88 MHz.</p> <p>0110 ~ 1000: Reserved.</p> <p>1001: 2 kHz.</p> <p>1010: 4 kHz.</p> <p>1011 ~ 1111: Reserved.</p> <p>The required frequency should not be set higher than frequency of the input clock.</p>																				

IN4_CNFG - Input Clock 4 Configuration

Address: 1AH																						
Type: Read / Write																						
Default Value: 00000011																						
7	6	5	4	3	2	1	0															
DIRECT_DIV	LOCK_8K	BUCKET_SEL1	BUCKET_SEL0	IN_FREQ3	IN_FREQ2	IN_FREQ1	IN_FREQ0															
Bit	Name	Description																				
7	DIRECT_DIV	Refer to the description of the LOCK_8K bit (b6, 1AH).																				
6	LOCK_8K	<p>This bit, together with the DIRECT_DIV bit (b7, 1AH), determines whether the DivN Divider or the Lock 8k Divider is used for IN4:</p> <table border="1" style="width: 100%; border-collapse: collapse;"> <thead> <tr> <th>DIRECT_DIV bit</th> <th>LOCK_8K bit</th> <th>Used Divider</th> </tr> </thead> <tbody> <tr> <td style="text-align: center;">0</td> <td style="text-align: center;">0</td> <td style="text-align: center;">Both bypassed (default)</td> </tr> <tr> <td style="text-align: center;">0</td> <td style="text-align: center;">1</td> <td style="text-align: center;">Lock 8k Divider</td> </tr> <tr> <td style="text-align: center;">1</td> <td style="text-align: center;">0</td> <td style="text-align: center;">DivN Divider</td> </tr> <tr> <td style="text-align: center;">1</td> <td style="text-align: center;">1</td> <td style="text-align: center;">Reserved</td> </tr> </tbody> </table>						DIRECT_DIV bit	LOCK_8K bit	Used Divider	0	0	Both bypassed (default)	0	1	Lock 8k Divider	1	0	DivN Divider	1	1	Reserved
DIRECT_DIV bit	LOCK_8K bit	Used Divider																				
0	0	Both bypassed (default)																				
0	1	Lock 8k Divider																				
1	0	DivN Divider																				
1	1	Reserved																				
5 - 4	BUCKET_SEL[1:0]	<p>These bits select one of the four groups of leaky bucket configuration registers for IN4</p> <p>00: Group 0; the addresses of the configuration registers are 31H ~ 34H. (default)</p> <p>01: Group 1; the addresses of the configuration registers are 35H ~ 38H.</p> <p>10: Group 2; the addresses of the configuration registers are 39H ~ 3CH.</p> <p>11: Group 3; the addresses of the configuration registers are 3DH ~ 40H.</p>																				
3 - 0	IN_FREQ[3:0]	<p>These bits set the DPLL required frequency for IN4:</p> <p>0000: 8 kHz.</p> <p>0001: 1.544 MHz (when the IN_SONET_SDH bit (b2, 09H) is '1') / 2.048 MHz (when the IN_SONET_SDH bit (b2, 09H) is '0').</p> <p>0010: 6.48 MHz.</p> <p>0011: 19.44 MHz. (default)</p> <p>0100: 25.92 MHz.</p> <p>0101: 38.88 MHz.</p> <p>0110 ~ 1000: Reserved.</p> <p>1001: 2 kHz.</p> <p>1010: 4 kHz.</p> <p>1011 ~ 1111: Reserved.</p> <p>For IN4, the required frequency should not be set higher than frequency of the input clock.</p>																				

IN5_CNFG - Input Clock 5 Configuration

Address: 1FH																						
Type: Read / Write																						
Default Value: 0000XXXX																						
7	6	5	4	3	2	1	0															
DIRECT_DIV	LOCK_8K	BUCKET_SEL1	BUCKET_SEL0	IN_FREQ3	IN_FREQ2	IN_FREQ1	IN_FREQ0															
Bit	Name	Description																				
7	DIRECT_DIV	Refer to the description of the LOCK_8K bit (b6, 1FH).																				
6	LOCK_8K	<p>This bit, together with the DIRECT_DIV bit (b7, 1FH), determines whether the DivN Divider or the Lock 8k Divider is used for IN5:</p> <table border="1" style="width: 100%; border-collapse: collapse;"> <thead> <tr> <th>DIRECT_DIV bit</th> <th>LOCK_8K bit</th> <th>Used Divider</th> </tr> </thead> <tbody> <tr> <td style="text-align: center;">0</td> <td style="text-align: center;">0</td> <td style="text-align: center;">Both bypassed (default)</td> </tr> <tr> <td style="text-align: center;">0</td> <td style="text-align: center;">1</td> <td style="text-align: center;">Lock 8k Divider</td> </tr> <tr> <td style="text-align: center;">1</td> <td style="text-align: center;">0</td> <td style="text-align: center;">DivN Divider</td> </tr> <tr> <td style="text-align: center;">1</td> <td style="text-align: center;">1</td> <td style="text-align: center;">Reserved</td> </tr> </tbody> </table>						DIRECT_DIV bit	LOCK_8K bit	Used Divider	0	0	Both bypassed (default)	0	1	Lock 8k Divider	1	0	DivN Divider	1	1	Reserved
DIRECT_DIV bit	LOCK_8K bit	Used Divider																				
0	0	Both bypassed (default)																				
0	1	Lock 8k Divider																				
1	0	DivN Divider																				
1	1	Reserved																				
5 - 4	BUCKET_SEL[1:0]	<p>These bits select one of the four groups of leaky bucket configuration registers for IN5:</p> <p>00: Group 0; the addresses of the configuration registers are 31H ~ 34H. (default)</p> <p>01: Group 1; the addresses of the configuration registers are 35H ~ 38H.</p> <p>10: Group 2; the addresses of the configuration registers are 39H ~ 3CH.</p> <p>11: Group 3; the addresses of the configuration registers are 3DH ~ 40H.</p>																				
3 - 0	IN_FREQ[3:0]	<p>These bits set the DPLL required frequency for IN5:</p> <p>0000: 8 kHz.</p> <p>0001: 1.544 MHz (when the IN_SONET_SDH bit (b2, 09H) is '1') / 2.048 MHz (when the IN_SONET_SDH bit (b2, 09H) is '0').</p> <p>0010: 6.48 MHz.</p> <p>0011: 19.44 MHz.</p> <p>0100: 25.92 MHz.</p> <p>0101: 38.88 MHz.</p> <p>0110 ~ 1000: Reserved.</p> <p>1001: 2 kHz.</p> <p>1010: 4 kHz.</p> <p>1011 ~ 1111: Reserved.</p> <p>For IN5, the required frequency should not be set higher than that of the input clock.</p> <p>The default value of these bits depends on the device application as follows:</p> <p>In Master / Slave application, when the device is configured as the Master, the default value is '0001'; when the device is configured as the Slave, the default value is '0010'.</p>																				

PRE_DIV_CH_CNFG - DivN Divider Channel Selection

Address: 23H							
Type: Read / Write							
Default Value: XXXX0000							
7	6	5	4	3	2	1	0
-	-	-	-	PRE_DIV_CH_VALUE3	PRE_DIV_CH_VALUE2	PRE_DIV_CH_VALUE1	PRE_DIV_CH_VALUE0
Bit	Name	Description					
7 - 4	-	Reserved.					
3 - 0	PRE_DIV_CH_VALUE[3:0]	<p>This register is an indirect address register for Register 24H and 25H.</p> <p>These bits select an input clock. The value set in the PRE_DIVN_VALUE[14:0] bits (25H, 24H) is available for the selected input clock.</p> <p>0000: Reserved. (default)</p> <p>0001, 0010: Reserved.</p> <p>0011: IN1.</p> <p>0100: IN2.</p> <p>0101: IN3</p> <p>0110: IN4</p> <p>0111, 1000, 1001, 1010: Reserved</p> <p>1011: IN5</p> <p>1100, 1101, 1110, 1111: Reserved.</p>					

PRE_DIVN[7:0]_CNFG - DivN Divider Division Factor Configuration 1

Address: 24H							
Type: Read / Write							
Default Value: 00000000							
7	6	5	4	3	2	1	0
PRE_DIVN_VA LUE7	PRE_DIVN_VA LUE6	PRE_DIVN_VA LUE5	PRE_DIVN_VA LUE4	PRE_DIVN_VA LUE3	PRE_DIVN_VA LUE2	PRE_DIVN_VA LUE1	PRE_DIVN_VA LUE0
Bit	Name	Description					
7 - 0	PRE_DIVN_VALUE[7:0]	Refer to the description of the PRE_DIVN_VALUE[14:8] bits (b6~0, 25H).					

PRE_DIVN[14:8]_CNFG - DivN Divider Division Factor Configuration 2

Address: 25H							
Type: Read / Write							
Default Value: X0000000							
7	6	5	4	3	2	1	0
-	PRE_DIVN_VAL UE14	PRE_DIVN_VAL UE13	PRE_DIVN_VAL UE12	PRE_DIVN_VAL UE11	PRE_DIVN_VAL UE10	PRE_DIVN_VAL UE9	PRE_DIVN_VAL UE8
Bit	Name	Description					
7	-	Reserved.					
6 - 0	PRE_DIVN_VALUE[14:8]	<p>The division factor for an input clock is the value in the PRE_DIVN_VALUE[14:0] bits plus 1. The input clock is selected by the PRE_DIV_CH_VALUE[3:0] bits (b3~0, 23H). A value from '1' to '4BEF' (Hex) can be written into, corresponding to a division factor from 2 to 19440. The others are reserved. So the DivN Divider only supports an input clock whose frequency is less than or equal to (\leq) 155.52 MHz.</p> <p>The division factor setting should observe the following order: 1. Write the lower eight bits of the division factor to the PRE_DIVN_VALUE[7:0] bits; 2. Write the higher eight bits of the division factor to the PRE_DIVN_VALUE[14:8] bits.</p>					

IN1_IN2_SEL_PRIORITY_CNFG - Input Clock 1 & 2 Priority Configuration *

Address: 27H							
Type: Read / Write							
Default Value: T0 - 01010100 / T4 - 00000000							
7	6	5	4	3	2	1	0
IN2_SEL_PRIORITY3	IN2_SEL_PRIORITY2	IN2_SEL_PRIORITY1	IN2_SEL_PRIORITY0	IN1_SEL_PRIORITY3	IN1_SEL_PRIORITY2	IN1_SEL_PRIORITY1	IN1_SEL_PRIORITY0
Bit	Name	Description					
7 - 4	INn_SEL_PRIORITY[3:0]	These bits set the priority of the corresponding INn. Here n is 2. 0000: Disable INn for automatic selection. (T4 default) 0001: Priority 1. 0010: Priority 2. 0011: Priority 3. 0100: Priority 4. 0101: Priority 5. (T0 default) 0110: Priority 6. 0111: Priority 7. 1000: Priority 8. 1001: Priority 9. 1010: Priority 10. 1011: Priority 11. 1100: Priority 12. 1101: Priority 13. 1110: Priority 14. 1111: Priority 15.					
3 - 0	INn_SEL_PRIORITY[3:0]	These bits set the priority of the corresponding INn. Here n is 1. 0000: Disable INn for automatic selection. (T4 default) 0001: Priority 1. 0010: Priority 2. 0011: Priority 3. 0100: Priority 4. (T0 default) 0101: Priority 5. 0110: Priority 6. 0111: Priority 7. 1000: Priority 8. 1001: Priority 9. 1010: Priority 10. 1011: Priority 11. 1100: Priority 12. 1101: Priority 13. 1110: Priority 14. 1111: Priority 15.					

IN3_IN4_SEL_PRIORITY_CNFG - Input Clock 3 & 4 Priority Configuration *

Address: 28H
 Type: Read / Write
 Default Value: T0/T4 - 01110110

7	6	5	4	3	2	1	0
IN4_SEL_PRIORITY3	IN4_SEL_PRIORITY2	IN4_SEL_PRIORITY1	IN4_SEL_PRIORITY0	IN3_SEL_PRIORITY3	IN3_SEL_PRIORITY2	IN3_SEL_PRIORITY1	IN3_SEL_PRIORITY0

Bit	Name	Description
7 - 4	INn_SEL_PRIORITY[3:0]	These bits set the priority of the corresponding INn. Here n is 4. 0000: Disable INn for automatic selection. 0001: Priority 1. 0010: Priority 2. 0011: Priority 3. 0100: Priority 4. 0101: Priority 5. 0110: Priority 6. 0111: Priority 7. (default) 1000: Priority 8. 1001: Priority 9. 1010: Priority 10. 1011: Priority 11. 1100: Priority 12. 1101: Priority 13. 1110: Priority 14. 1111: Priority 15.
3 - 0	INn_SEL_PRIORITY[3:0]	These bits set the priority of the corresponding INn. Here n is 3. 0000: Disable INn for automatic selection. 0001: Priority 1. 0010: Priority 2. 0011: Priority 3. 0100: Priority 4. 0101: Priority 5. 0110: Priority 6. (default) 0111: Priority 7. 1000: Priority 8. 1001: Priority 9. 1010: Priority 10. 1011: Priority 11. 1100: Priority 12. 1101: Priority 13. 1110: Priority 14. 1111: Priority 15.

IN5_SEL_PRIORITY_CNFG - Input Clock 5 Priority Configuration *

Address: 2BH							
Type: Read / Write							
Default Value: 11011100 (T0 Master)/11010001 (T0 Slave) 00000000 (T4)							
7	6	5	4	3	2	1	0
-	-	-	-	IN5_SEL_PRIORITY3	IN5_SEL_PRIORITY2	IN5_SEL_PRIORITY1	IN5_SEL_PRIORITY0
Bit	Name	Description					
7 - 4	-	Reserved					
3 - 0	INn_SEL_PRIORITY[3:0]	These bits set the priority of the corresponding INn. Here n is 5: 0000: Disable INn for automatic selection. (T4 default) 0001: Priority 1. (T0 Slave default) 0010: Priority 2. 0011: Priority 3. 0100: Priority 4. 0101: Priority 5. 0110: Priority 6. 0111: Priority 7. 1000: Priority 8. 1001: Priority 9. 1010: Priority 10. 1011: Priority 11. 1100: Priority 12. (T0 Master default) 1101: Priority 13. 1110: Priority 14. 1111: Priority 15.					

7.2.4 INPUT CLOCK QUALITY MONITORING CONFIGURATION & STATUS REGISTERS

FREQ_MON_FACTOR_CNFG - Factor of Frequency Monitor Configuration

Address: 2EH							
Type: Read / Write							
Default Value: XXXX1011							
7	6	5	4	3	2	1	0
-	-	-	-	FREQ_MON_F ACTOR3	FREQ_MON_F ACTOR2	FREQ_MON_F ACTOR1	FREQ_MON_F ACTOR0
Bit	Name	Description					
7 - 4	-	Reserved.					
3 - 0	FREQ_MON_FACTOR[3:0]	<p>These bits determine a factor. The factor has a relationship with the frequency hard alarm threshold in ppm (refer to the description of the ALL_FREQ_HARD_THRESHOLD[3:0] bits (b3~0, 2FH)) and with the frequency of the input clock with respect to the master clock in ppm (refer to the description of the IN_FREQ_VALUE[7:0] bits (b7~0, 42H)). The factor represents the accuracy of the frequency monitor and should be set according to the requirements of different applications.</p> <p>0000: 0.0032. 0001: 0.0064. 0010: 0.0127. 0011: 0.0257. 0100: 0.0514. 0101: 0.103. 0110: 0.206. 0111: 0.412. 1000: 0.823. 1001: 1.646. 1010: 3.292. 1011: 3.81. (default) 1100 - 1111: 4.6.</p>					

ALL_FREQ_MON_THRESHOLD_CNFG - Frequency Monitor Threshold for All Input Clocks Configuration

Address: 2FH							
Type: Read / Write							
Default Value: 00100011							
7	6	5	4	3	2	1	0
-	-	-	-	ALL_FREQ_HARD_THRESHOLD3	ALL_FREQ_HARD_THRESHOLD2	ALL_FREQ_HARD_THRESHOLD1	ALL_FREQ_HARD_THRESHOLD0
Bit	Name	Description					
7 - 4	ALL_FREQ_HARD_THRESHOLD[7:4]	<p>These bits are the accepting threshold of reference clock monitoring. The frequency hard alarm threshold in ppm is calculated as follows:</p> <p>Frequency Hard Alarm Threshold (ppm) = (HARD_FREQ_MON_THRESHOLD[7:4] + 1) X FREQ_MON_FACTOR[3:0] (b3~0, 2EH)</p> <p>This threshold is symmetrical about zero. A value of 0010 bin corresponds to an alarm limit of +/- 11.43 ppm.</p>					
3 - 0	ALL_FREQ_HARD_THRESHOLD[3:0]	<p>These bits are the rejecting threshold of reference clock monitoring. The frequency hard alarm threshold in ppm can be calculated as follows:</p> <p>Frequency Hard Alarm Threshold (ppm) = (ALL_FREQ_HARD_THRESHOLD[3:0] + 1) X FREQ_MON_FACTOR[3:0] (b3~0, 2EH)</p> <p>This threshold is symmetrical about zero. A value of 0010 bin corresponds to an alarm limit of +/- 11.43 ppm.</p>					

UPPER_THRESHOLD_0_CNFG - Upper Threshold for Leaky Bucket Configuration 0

Address: 31H							
Type: Read / Write							
Default Value: 00000110							
7	6	5	4	3	2	1	0
UPPER_THRE_SHOLD_0_DAT A7	UPPER_THRE_SHOLD_0_DAT A6	UPPER_THRE_SHOLD_0_DAT A5	UPPER_THRE_SHOLD_0_DAT A4	UPPER_THRE_SHOLD_0_DAT A3	UPPER_THRE_SHOLD_0_DAT A2	UPPER_THRE_SHOLD_0_DAT A1	UPPER_THRE_SHOLD_0_DAT A0
Bit	Name	Description					
7 - 0	UPPER_THRESHOLD_0_DATA[7:0]	<p>These bits set an upper threshold for the internal leaky bucket accumulator. When the number of the accumulated events is above this threshold, a no-activity alarm is raised.</p>					

LOWER_THRESHOLD_0_CNFG - Lower Threshold for Leaky Bucket Configuration 0

Address: 32H							
Type: Read / Write							
Default Value: 00000100							
7	6	5	4	3	2	1	0
LOWER_THRE SHOLD_0_DAT A7	LOWER_THRE SHOLD_0_DAT A6	LOWER_THRE SHOLD_0_DAT A5	LOWER_THRE SHOLD_0_DAT A4	LOWER_THRE SHOLD_0_DAT A3	LOWER_THRE SHOLD_0_DAT A2	LOWER_THRE SHOLD_0_DAT A1	LOWER_THRE SHOLD_0_DAT A0
Bit	Name	Description					
7 - 0	LOWER_THRESHOLD_0_DATA[7:0]	These bits set a lower threshold for the internal leaky bucket accumulator. When the number of the accumulated events is below this threshold, the no-activity alarm is cleared.					

BUCKET_SIZE_0_CNFG - Bucket Size for Leaky Bucket Configuration 0

Address: 33H							
Type: Read / Write							
Default Value: 00001000							
7	6	5	4	3	2	1	0
BUCKET_SIZE _0_DATA7	BUCKET_SIZE _0_DATA6	BUCKET_SIZE _0_DATA5	BUCKET_SIZE _0_DATA4	BUCKET_SIZE _0_DATA3	BUCKET_SIZE _0_DATA2	BUCKET_SIZE _0_DATA1	BUCKET_SIZE _0_DATA0
Bit	Name	Description					
7 - 0	BUCKET_SIZE_0_DATA[7:0]	These bits set a bucket size for the internal leaky bucket accumulator. If the number of the accumulated events reach the bucket size, the accumulator will stop increasing even if further events are detected.					

DECAY_RATE_0_CNFG - Decay Rate for Leaky Bucket Configuration 0

Address: 34H							
Type: Read / Write							
Default Value: XXXXXX01							
7	6	5	4	3	2	1	0
-	-	-	-	-	-	DECAY_RATE_ _0_DATA1	DECAY_RATE_ _0_DATA0
Bit	Name	Description					
7 - 2	-	Reserved.					
1 - 0	DECAY_RATE_0_DATA[1:0]	These bits set a decay rate for the internal leaky bucket accumulator: 00: The accumulator decreases by 1 in every 128 ms with no event detected. 01: The accumulator decreases by 1 in every 256 ms with no event detected. (default) 10: The accumulator decreases by 1 in every 512 ms with no event detected. 11: The accumulator decreases by 1 in every 1024 ms with no event detected.					

UPPER_THRESHOLD_1_CNFG - Upper Threshold for Leaky Bucket Configuration 1

Address: 35H							
Type: Read / Write							
Default Value: 00000110							
7	6	5	4	3	2	1	0
UPPER_THRE SHOLD_1_DAT A7	UPPER_THRE SHOLD_1_DAT A6	UPPER_THRE SHOLD_1_DAT A5	UPPER_THRE SHOLD_1_DAT A4	UPPER_THRE SHOLD_1_DAT A3	UPPER_THRE SHOLD_1_DAT A2	UPPER_THRE SHOLD_1_DAT A1	UPPER_THRE SHOLD_1_DAT A0
Bit	Name	Description					
7 - 0	UPPER_THRESHOLD_1_DATA[7:0]	These bits set an upper threshold for the internal leaky bucket accumulator. When the number of the accumulated events is above this threshold, a no-activity alarm is raised.					

LOWER_THRESHOLD_1_CNFG - Lower Threshold for Leaky Bucket Configuration 1

Address: 36H							
Type: Read / Write							
Default Value: 00000100							
7	6	5	4	3	2	1	0
LOWER_THRE SHOLD_1_DAT A7	LOWER_THRE SHOLD_1_DAT A6	LOWER_THRE SHOLD_1_DAT A5	LOWER_THRE SHOLD_1_DAT A4	LOWER_THRE SHOLD_1_DAT A3	LOWER_THRE SHOLD_1_DAT A2	LOWER_THRE SHOLD_1_DAT A1	LOWER_THRE SHOLD_1_DAT A0
Bit	Name	Description					
7 - 0	LOWER_THRESHOLD_1_DATA[7:0]	These bits set a lower threshold for the internal leaky bucket accumulator. When the number of the accumulated events is below this threshold, the no-activity alarm is cleared.					

BUCKET_SIZE_1_CNFG - Bucket Size for Leaky Bucket Configuration 1

Address: 37H							
Type: Read / Write							
Default Value: 00001000							
7	6	5	4	3	2	1	0
BUCKET_SIZE _1_DATA7	BUCKET_SIZE _1_DATA6	BUCKET_SIZE _1_DATA5	BUCKET_SIZE _1_DATA4	BUCKET_SIZE _1_DATA3	BUCKET_SIZE _1_DATA2	BUCKET_SIZE _1_DATA1	BUCKET_SIZE _1_DATA0
Bit	Name	Description					
7 - 0	BUCKET_SIZE_1_DATA[7:0]	These bits set a bucket size for the internal leaky bucket accumulator. If the number of the accumulated events reach the bucket size, the accumulator will stop increasing even if further events are detected.					

DECAY_RATE_1_CNFG - Decay Rate for Leaky Bucket Configuration 1

Address: 38H Type: Read / Write Default Value: XXXXXX01							
7	6	5	4	3	2	1	0
-	-	-	-	-	-	DECAY_RATE_1_DATA1	DECAY_RATE_1_DATA0
Bit	Name	Description					
7 - 2	-	Reserved.					
1 - 0	DECAY_RATE_1_DATA[1:0]	These bits set a decay rate for the internal leaky bucket accumulator: 00: The accumulator decreases by 1 in every 128 ms with no event detected. 01: The accumulator decreases by 1 in every 256 ms with no event detected. (default) 10: The accumulator decreases by 1 in every 512 ms with no event detected. 11: The accumulator decreases by 1 in every 1024 ms with no event detected.					

UPPER_THRESHOLD_2_CNFG - Upper Threshold for Leaky Bucket Configuration 2

Address: 39H Type: Read / Write Default Value: 00000110							
7	6	5	4	3	2	1	0
UPPER_THRE_SHOLD_2_DAT A7	UPPER_THRE_SHOLD_2_DAT A6	UPPER_THRE_SHOLD_2_DAT A5	UPPER_THRE_SHOLD_2_DAT A4	UPPER_THRE_SHOLD_2_DAT A3	UPPER_THRE_SHOLD_2_DAT A2	UPPER_THRE_SHOLD_2_DAT A1	UPPER_THRE_SHOLD_2_DAT A0
Bit	Name	Description					
7 - 0	UPPER_THRESHOLD_2_DATA[7:0]	These bits set an upper threshold for the internal leaky bucket accumulator. When the number of the accumulated events is above this threshold, a no-activity alarm is raised.					

LOWER_THRESHOLD_2_CNFG - Lower Threshold for Leaky Bucket Configuration 2

Address: 3AH Type: Read / Write Default Value: 00000100							
7	6	5	4	3	2	1	0
LOWER_THRE_SHOLD_2_DAT A7	LOWER_THRE_SHOLD_2_DAT A6	LOWER_THRE_SHOLD_2_DAT A5	LOWER_THRE_SHOLD_2_DAT A4	LOWER_THRE_SHOLD_2_DAT A3	LOWER_THRE_SHOLD_2_DAT A2	LOWER_THRE_SHOLD_2_DAT A1	LOWER_THRE_SHOLD_2_DAT A0
Bit	Name	Description					
7 - 0	LOWER_THRESHOLD_2_DATA[7:0]	These bits set a lower threshold for the internal leaky bucket accumulator. When the number of the accumulated events is below this threshold, the no-activity alarm is cleared.					

BUCKET_SIZE_2_CNFG - Bucket Size for Leaky Bucket Configuration 2

Address: 3BH							
Type: Read / Write							
Default Value: 00001000							
7	6	5	4	3	2	1	0
BUCKET_SIZE_2_DATA7	BUCKET_SIZE_2_DATA6	BUCKET_SIZE_2_DATA5	BUCKET_SIZE_2_DATA4	BUCKET_SIZE_2_DATA3	BUCKET_SIZE_2_DATA2	BUCKET_SIZE_2_DATA1	BUCKET_SIZE_2_DATA0
Bit	Name	Description					
7 - 0	BUCKET_SIZE_2_DATA[7:0]	These bits set a bucket size for the internal leaky bucket accumulator. If the number of the accumulated events reaches the bucket size, the accumulator will stop increasing even if further events are detected.					

DECAY_RATE_2_CNFG - Decay Rate for Leaky Bucket Configuration 2

Address: 3CH							
Type: Read / Write							
Default Value: XXXXXX01							
7	6	5	4	3	2	1	0
-	-	-	-	-	-	DECAY_RATE_2_DATA1	DECAY_RATE_2_DATA0
Bit	Name	Description					
7 - 2	-	Reserved.					
1 - 0	DECAY_RATE_2_DATA[1:0]	These bits set a decay rate for the internal leaky bucket accumulator: 00: The accumulator decreases by 1 in every 128 ms with no event detected. 01: The accumulator decreases by 1 in every 256 ms with no event detected. (default) 10: The accumulator decreases by 1 in every 512 ms with no event detected. 11: The accumulator decreases by 1 in every 1024 ms with no event detected.					

UPPER_THRESHOLD_3_CNFG - Upper Threshold for Leaky Bucket Configuration 3

Address: 3DH							
Type: Read / Write							
Default Value: 00000110							
7	6	5	4	3	2	1	0
UPPER_THRE SHOLD_3_DAT A7	UPPER_THRE SHOLD_3_DAT A6	UPPER_THRE SHOLD_3_DAT A5	UPPER_THRE SHOLD_3_DAT A4	UPPER_THRE SHOLD_3_DAT A3	UPPER_THRE SHOLD_3_DAT A2	UPPER_THRE SHOLD_3_DAT A1	UPPER_THRE SHOLD_3_DAT A0
Bit	Name	Description					
7 - 0	UPPER_THRESHOLD_3_DATA[7:0]	These bits set an upper threshold for the internal leaky bucket accumulator. When the number of the accumulated events is above this threshold, a no-activity alarm is raised.					

LOWER_THRESHOLD_3_CNFG - Lower Threshold for Leaky Bucket Configuration 3

Address: 3EH
 Type: Read / Write
 Default Value: 00000100

7	6	5	4	3	2	1	0
LOWER_THRE SHOLD_3_DAT A7	LOWER_THRE SHOLD_3_DAT A6	LOWER_THRE SHOLD_3_DAT A5	LOWER_THRE SHOLD_3_DAT A4	LOWER_THRE SHOLD_3_DAT A3	LOWER_THRE SHOLD_3_DAT A2	LOWER_THRE SHOLD_3_DAT A1	LOWER_THRE SHOLD_3_DAT A0

Bit	Name	Description
7 - 0	LOWER_THRESHOLD_3_DATA[7:0]	These bits set a lower threshold for the internal leaky bucket accumulator. When the number of the accumulated events is below this threshold, the no-activity alarm is cleared.

BUCKET_SIZE_3_CNFG - Bucket Size for Leaky Bucket Configuration 3

Address: 3FH
 Type: Read / Write
 Default Value: 00001000

7	6	5	4	3	2	1	0
BUCKET_SIZE _3_DATA7	BUCKET_SIZE _3_DATA6	BUCKET_SIZE _3_DATA5	BUCKET_SIZE _3_DATA4	BUCKET_SIZE _3_DATA3	BUCKET_SIZE _3_DATA2	BUCKET_SIZE _3_DATA1	BUCKET_SIZE _3_DATA0

Bit	Name	Description
7 - 0	BUCKET_SIZE_3_DATA[7:0]	These bits set a bucket size for the internal leaky bucket accumulator. If the number of the accumulated events reaches the bucket size, the accumulator will stop increasing even if further events are detected.

DECAY_RATE_3_CNFG - Decay Rate for Leaky Bucket Configuration 3

Address: 40H
 Type: Read / Write
 Default Value: XXXXXX01

7	6	5	4	3	2	1	0
-	-	-	-	-	-	DECAY_RATE_ 3_DATA1	DECAY_RATE_ 3_DATA0

Bit	Name	Description
7 - 2	-	Reserved.
1 - 0	DECAY_RATE_3_DATA[1:0]	These bits set a decay rate for the internal leaky bucket accumulator: 00: The accumulator decreases by 1 in every 128 ms with no event detected. 01: The accumulator decreases by 1 in every 256 ms with no event detected. (default) 10: The accumulator decreases by 1 in every 512 ms with no event detected. 11: The accumulator decreases by 1 in every 1024 ms with no event detected.

IN_FREQ_READ_CH_CNFG - Input Clock Frequency Read Channel Selection

Address: 41H Type: Read / Write Default Value: XXXX0000							
7	6	5	4	3	2	1	0
-	-	-	-	IN_FREQ_READ _CH3	IN_FREQ_READ _CH2	IN_FREQ_READ _CH1	IN_FREQ_READ _CH0
Bit	Name	Description					
7 - 4	-	Reserved.					
3 - 0	IN_FREQ_READ_CH[3:0]	These bits select an input clock, the frequency of which with respect to the reference clock can be read. 0000: Reserved. (default) 0001, 0010: Reserved. 0011: IN1. 0100: IN2. 0101: IN3. 0110: IN4. 0111, 1000, 1001, 1010: Reserved. 1011: IN5. 1100, 1101, 1110, 1111: Reserved.					

IN_FREQ_READ_STS - Input Clock Frequency Read Value

Address: 42H Type: Read Default Value: 00000000							
7	6	5	4	3	2	1	0
IN_FREQ_VAL UE7	IN_FREQ_VAL UE6	IN_FREQ_VAL UE5	IN_FREQ_VAL UE4	IN_FREQ_VAL UE3	IN_FREQ_VAL UE2	IN_FREQ_VAL UE1	IN_FREQ_VAL UE0
Bit	Name	Description					
7 - 0	IN_FREQ_VALUE[7:0]	These bits represent a 2's complement signed integer. If the value is multiplied by the value in the FREQ_MON_FACTOR[3:0] bits (b3~0, 2EH), the frequency of an input clock with respect to the reference clock in ppm will be gotten. The input clock is selected by the IN_FREQ_READ_CH[3:0] bits (b3~0, 41H). The value in these bits is updated every 16 seconds, starting when an input clock is selected.					

IN1_IN2_STS - Input Clock 1 & 2 Status

Address: 44H
 Type: Read
 Default Value: X110X110

7	6	5	4	3	2	1	0
-	IN2_FREQ_HARD_ALARM	IN2_NO_ACTIVITY_ALARM	IN2_PH_LOCK_ALARM	-	IN1_FREQ_HARD_ALARM	IN1_NO_ACTIVITY_ALARM	IN1_PH_LOCK_ALARM

Bit	Name	Description
7	-	Reserved.
6	IN2_FREQ_HARD_ALARM	This bit indicates whether IN2 is in frequency hard alarm status. 0: Input frequency within hard accept region. 1: Input frequency over the hard reject region.
5	IN2_NO_ACTIVITY_ALARM	This bit indicates whether IN2 is in frequency hard alarm status. 0: No no-activity alarm. 1: In no-activity alarm status. (default)
4	IN2_PH_LOCK_ALARM	This bit indicates whether IN2 is in phase lock alarm status. 0: No phase lock alarm. (default) 1: In phase lock alarm status. If the PH_ALARM_TIMEOUT bit (b5, 09H) is '0', this bit is cleared by writing '1' to this bit; if the PH_ALARM_TIMEOUT bit (b5, 09H) is '1', this bit is cleared after a period (= TIME_OUT_VALUE[5:0] (b5~0, 08H) X MULTI_FACTOR[1:0] (b7~6, 08H) in seconds) which starts from when the alarm is raised.
3	-	Reserved.
2	IN1_FREQ_HARD_ALARM	This bit indicates whether IN1 is in frequency hard alarm status. 0: Input frequency within hard accept region. 1: Input frequency over the hard reject region.
1	IN1_NO_ACTIVITY_ALARM	This bit indicates whether IN1 is in no-activity alarm status. 0: No no-activity alarm. 1: In no-activity alarm status. (default)
0	IN1_PH_LOCK_ALARM	This bit indicates whether IN1 is in phase lock alarm status. 0: No phase lock alarm. (default) 1: In phase lock alarm status. If the PH_ALARM_TIMEOUT bit (b5, 09H) is '0', this bit is cleared by writing '1' to this bit; if the PH_ALARM_TIMEOUT bit (b5, 09H) is '1', this bit is cleared after a period (= TIME_OUT_VALUE[5:0] (b5~0, 08H) X MULTI_FACTOR[1:0] (b7~6, 08H) in seconds) which starts from when the alarm is raised.

IN3_IN4_STS - Input Clock 3 & 4 Status

Address: 45H							
Type: Read							
Default Value: X110X110							
7	6	5	4	3	2	1	0
-	IN4_FREQ_HARD_ALARM	IN4_NO_ACTIVITY_ALARM	IN4_PH_LOCK_ALARM	-	IN3_FREQ_HARD_ALARM	IN3_NO_ACTIVITY_ALARM	IN3_PH_LOCK_ALARM
Bit	Name	Description					
7	-	Reserved.					
6	IN4_FREQ_HARD_ALARM	This bit indicates whether IN4 is in frequency hard alarm status. 0: Input frequency within hard accept region. 1: Input frequency over the hard reject region.					
5	IN4_NO_ACTIVITY_ALARM	This bit indicates whether IN4 is in no-activity alarm status. 0: No no-activity alarm. 1: In no-activity alarm status. (default)					
4	IN4_PH_LOCK_ALARM	This bit indicates whether IN4 is in phase lock alarm status. 0: No phase lock alarm. (default) 1: In phase lock alarm status. If the PH_ALARM_TIMEOUT bit (b5, 09H) is '0', this bit is cleared by writing '1' to this bit; if the PH_ALARM_TIMEOUT bit (b5, 09H) is '1', this bit is cleared after a period (= TIME_OUT_VALUE[5:0] (b5~0, 08H) X MULTI_FACTOR[1:0] (b7~6, 08H) in seconds) which starts from when the alarm is raised.					
3	-	Reserved.					
2	IN3_FREQ_HARD_ALARM	This bit indicates whether IN3 is in frequency hard alarm status. 0: Input frequency within hard accept region. 1: Input frequency over the hard reject region.					
1	IN3_NO_ACTIVITY_ALARM	This bit indicates whether IN3 is in no-activity alarm status. 0: No no-activity alarm. 1: In no-activity alarm status. (default)					
0	IN3_PH_LOCK_ALARM	This bit indicates whether IN3 is in phase lock alarm status. 0: No phase lock alarm. (default) 1: In phase lock alarm status. If the PH_ALARM_TIMEOUT bit (b5, 09H) is '0', this bit is cleared by writing '1' to this bit; if the PH_ALARM_TIMEOUT bit (b5, 09H) is '1', this bit is cleared after a period (= TIME_OUT_VALUE[5:0] (b5~0, 08H) X MULTI_FACTOR[1:0] (b7~6, 08H) in seconds) which starts from when the alarm is raised.					

IN5_STS - Input Clock 5 Status

Address: 48H
 Type: Read
 Default Value: X110X110

7	6	5	4	3	2	1	0
-	-	-	-	-	IN5_FREQ_HA RD_ALARM	IN5_NO_ACTIV ITY_ALARM	IN5_PH_LOCK _ALARM

Bit	Name	Description
7-3	-	Reserved.
2	IN5_FREQ_HARD_ALARM	This bit indicates whether IN5 is in frequency hard alarm status. 0: Input frequency within hard accept region. 1: Input frequency over the hard reject region.
1	IN5_NO_ACTIVITY_ALARM	This bit indicates whether IN5 is in no-activity alarm status. 0: No no-activity alarm. 1: In no-activity alarm status. (default)
0	IN5_PH_LOCK_ALARM	This bit indicates whether IN5 is in phase lock alarm status. 0: No phase lock alarm. (default) 1: In phase lock alarm status. If the PH_ALARM_TIMEOUT bit (b5, 09H) is '0', this bit is cleared by writing '1' to this bit; if the PH_ALARM_TIMEOUT bit (b5, 09H) is '1', this bit is cleared after a period (= TIME_OUT_VALUE[5:0] (b5~0, 08H) X MULTI_FACTOR[1:0] (b7~6, 08H) in seconds) which starts from when the alarm is raised.

IDT CONFIDENTIAL

7.2.5 T0 / T4 DPLL INPUT CLOCK SELECTION REGISTERS

INPUT_VALID1_STS - Input Clocks Validity 1

Address: 4AH							
Type: Read							
Default Value: 00000000							
7	6	5	4	3	2	1	0
-	-	IN4	IN3	IN2	IN1	-	-
Bit	Name	Description					
7 - 6	-	Reserved.					
5 - 2	INn	This bit indicates the validity of the corresponding INn. Here n is any of 4 to 1. 0: Invalid. (default) 1: Valid.					
1 - 0	-	Reserved.					

INPUT_VALID2_STS - Input Clocks Validity 2

Address: 4BH							
Type: Read							
Default Value: XX000000							
7	6	5	4	3	2	1	0
-	-	-	-	-	IN5	-	-
Bit	Name	Description					
7 - 3	-	Reserved.					
2	IN5	This bit indicates the validity of IN5. 0: Invalid. (default) 1: Valid.					
1 - 0	-	Reserved.					

REMOTE_INPUT_VALID1_CNFG - Input Clocks Validity Configuration 1

Address: 4CH							
Type: Read / Write							
Default Value: 11111111							
7	6	5	4	3	2	1	0
-	-	IN4_VALID	IN3_VALID	IN2_VALID	IN1_VALID	-	-
Bit	Name	Description					
7 - 6	-	Reserved.					
5 - 2	INn_VALID	This bit controls whether the corresponding INn is allowed to be locked for automatic selection. Here n is any one of 4 to 1. 0: Enabled. 1: Disabled. (default)					
1 - 0	-	Reserved.					

REMOTE_INPUT_VALID2_CNFG - Input Clocks Validity Configuration 2

Address: 4DH Type: Read / Write Default Value: XX111111							
7	6	5	4	3	2	1	0
-	-	-	-	-	IN5_VALID	-	-
Bit	Name	Description					
7 - 3	-	Reserved.					
2	IN5_VALID	This bit controls whether IN5 is allowed to be locked for automatic selection. 0: Enabled. 1: Disabled. (default)					
1 - 0	-	Reserved.					

PRIORITY_TABLE1_STS - Priority Status 1 *

Address: 4EH Type: Read Default Value: 00000000							
7	6	5	4	3	2	1	0
HIGHEST_PRIORITY_VALIDATED3 TED3	HIGHEST_PRIORITY_VALIDATED2 TED2	HIGHEST_PRIORITY_VALIDATED1 TED1	HIGHEST_PRIORITY_VALIDATED0 TED0	CURRENTLY_SELECTED_INPUT3 UT3	CURRENTLY_SELECTED_INPUT2 UT2	CURRENTLY_SELECTED_INPUT1 UT1	CURRENTLY_SELECTED_INPUT0 UT0
Bit	Name	Description					
7 - 4	HIGHEST_PRIORITY_VALIDATED[3:0]	These bits indicate a qualified input clock with the highest priority. 0000: No input clock is qualified. (default) 0001, 0010: Reserved. 0011: IN1. 0100: IN2. 0101: IN3. 0110: IN4. 0111, 1000, 1001, 1010: Reserved. 1011: IN5. 1100, 1101, 1110, 1111: Reserved. Note that the input clock is indicated by these bits only when the corresponding INn (b5-2, 4CH) or INn (b2, 4DH) bit is '0'.					
3 - 0	CURRENTLY_SELECTED_INPUT[3:0]	These bits indicate the T0/T4 selected input clock. 0000: No input clock is selected; or the T4 selected input clock is the T0 DPLL output. (default) 0001, 0010: Reserved. 0011: IN1 is selected. 0100: IN2 is selected. 0101: IN3 is selected. 0110: IN4 is selected. 0111, 1000, 1001, 1010: Reserved. 1011: IN5 is selected. 1100, 1101, 1110, 1111: Reserved. Note that the input clock is indicated by these bits only when the corresponding INn (b5-2, 4CH) or INn (b2, 4DH) bit is '0'.					

PRIORITY_TABLE2_STS - Priority Status 2 *

Address: 4FH							
Type: Read							
Default Value: 00000000							
7	6	5	4	3	2	1	0
THIRD_HIGHEST_PRIORITY_VALIDATED3	THIRD_HIGHEST_PRIORITY_VALIDATED2	THIRD_HIGHEST_PRIORITY_VALIDATED1	THIRD_HIGHEST_PRIORITY_VALIDATED0	SECOND_HIGHEST_PRIORITY_VALIDATED3	SECOND_HIGHEST_PRIORITY_VALIDATED2	SECOND_HIGHEST_PRIORITY_VALIDATED1	SECOND_HIGHEST_PRIORITY_VALIDATED0
Bit	Name	Description					
7 - 4	THIRD_HIGHEST_PRIORITY_VALIDATED[3:0]	<p>These bits indicate a qualified input clock with the third highest priority.</p> <p>0000: No input clock is qualified. (default)</p> <p>0001, 0010: Reserved.</p> <p>0011: IN1.</p> <p>0100: IN2.</p> <p>0101: IN3.</p> <p>0110: IN4.</p> <p>0111, 1000, 1001, 1010: Reserved.</p> <p>1011: IN5.</p> <p>1100, 1101, 1110, 1111: Reserved.</p> <p>Note that the input clock is indicated by these bits only when the corresponding INn (b5-2, 4CH) or INn (b2, 4DH) bit is '0'.</p>					
3 - 0	SECOND_HIGHEST_PRIORITY_VALIDATED[3:0]	<p>These bits indicate a qualified input clock with the second highest priority.</p> <p>0000: No input clock is qualified. (default)</p> <p>0001, 0010: Reserved.</p> <p>0011: IN1.</p> <p>0100: IN2.</p> <p>0101: IN3.</p> <p>0110: IN4.</p> <p>0111, 1000, 1001, 1010: Reserved.</p> <p>1011: IN5.</p> <p>1100, 1101, 1110, 1111: Reserved.</p> <p>Note that the input clock is indicated by these bits only when the corresponding INn (b5-2, 4CH) or INn (b2, 4DH) bit is '0'.</p>					

T0_INPUT_SEL_CNFG - T0 Selected Input Clock Configuration

Address: 50H
 Type: Read / Write
 Default Value: XXXX0000

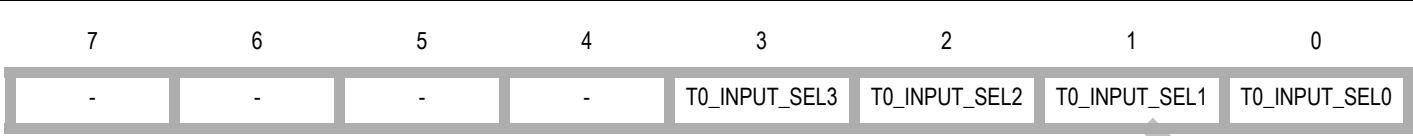

Bit	Name	Description
7 - 4	-	Reserved.
3 - 0	T0_INPUT_SEL[3:0]	This bit determines T0 input clock selection. It is valid only when the EXT_SW bit (b4, 0BH) is '0'. 0000: Automatic selection. (default) 0001, 0010: Reserved. 0011: Forced selection - IN1 is selected. 0100: Forced selection - IN2 is selected. 0101: Forced selection - IN3 is selected. 0110: Forced selection - IN4 is selected. 0111, 1000, 1001, 1010: Reserved. 1011: Forced selection - IN5 is selected. 1100, 1101, 1110, 1111: Reserved.

T4_INPUT_SEL_CNFG - T4 Selected Input Clock Configuration

Address: 51H							
Type: Read / Write							
Default Value: X0000000							
7	6	5	4	3	2	1	0
-	T4_LOCK_T0	T0_FOR_T4	T4_TEST_T0_PH	T4_INPUT_SEL3	T4_INPUT_SEL2	T4_INPUT_SEL1	T4_INPUT_SEL0
Bit	Name	Description					
7	-	Reserved.					
6	T4_LOCK_T0	This bit determines whether the T4 DPLL locks to a T0 DPLL output or locks independently from the T0 DPLL. 0: Independently from the T0 path. (default) 1: Locks to a 77.76 MHz or 8 kHz signal from the T0 DPLL 77.76 MHz path.					
5	T0_FOR_T4	This bit is valid only when the T4_LOCK_T0 bit (b6, 51H) is '1'. It determines whether a 77.76 MHz or 8 kHz signal from the T0 DPLL 77.76 MHz path is selected by the T4 DPLL. 0: 77.76 MHz. (default) 1: 8 kHz.					
4	T4_TEST_T0_PH	This bit determines whether T4 selected input clock is compared with the feedback signal of the T4 DPLL for T4 DPLL locking or is compared with the T0 selected input clock to get the phase difference between T0 and T4 selected input clocks. 0: The T4 DPLL output. (default) 1: The T0 selected input clock.					
3 - 0	T4_INPUT_SEL[3:0]	These bits are valid only when the T4_LOCK_T0 bit (b6, 51H) is '0'. They determines the T4 DPLL input clock selection. 0000: Automatic selection. (default) 0001, 0010: Reserved. 0011: Forced selection - IN1 is selected. 0100: Forced selection - IN2 is selected. 0101: Forced selection - IN3 is selected. 0110: Forced selection - IN4 is selected. 0111, 1000, 1001, 1010: Reserved. 1011: Forced selection - IN5 is selected. 1100, 1101, 1110, 1111: Reserved.					

7.2.6 T0 / T4 DPLL STATE MACHINE CONTROL REGISTERS

OPERATING_STS - DPLL Operating Status

Address: 52H							
Type: Read							
Default Value: 10000001							
7	6	5	4	3	2	1	0
EX_SYNC_ALARM_MON	T4_DPLL_LOCK	T0_DPLL_SOFT_FREQ_ALARM	T4_DPLL_SOFT_FREQ_ALARM	T0_DPLL_LOCK	T0_DPLL_OPERATING_MODE2	T0_DPLL_OPERATING_MODE1	T0_DPLL_OPERATING_MODE0
Bit	Name	Description					
7	EX_SYNC_ALARM_MON	This bit indicates whether the frame sync input signal is in external sync alarm status. 0: No external sync alarm. 1: In external sync alarm status. (default)					
6	T4_DPLL_LOCK	This bit indicates the T4 DPLL locking status. 0: Unlocked. (default) 1: Locked.					
5	T0_DPLL_SOFT_FREQ_ALARM	This bit indicates whether the T0 DPLL is in soft alarm status. 0: No T0 DPLL soft alarm. (default) 1: In T0 DPLL soft alarm status.					
4	T4_DPLL_SOFT_FREQ_ALARM	This bit indicates whether the T4 DPLL is in soft alarm status. 0: No T4 DPLL soft alarm. (default) 1: In T4 DPLL soft alarm status.					
3	T0_DPLL_LOCK	This bit indicates the T0 DPLL locking status. 0: Unlocked. (default) 1: Locked.					
2 - 0	T0_DPLL_OPERATING_MODE[2:0]	These bits indicate the current operating mode of T0 DPLL. 000: Reserved. 001: Free-Run. (default) 010: Holdover. 011: Reserved. 100: Locked. 101: Pre-Locked2. 110: Pre-Locked. 111: Lost-Phase.					

T0_OPERATING_MODE_CNFG - T0 DPLL Operating Mode Configuration

Address: 53H							
Type: Read / Write							
Default Value: XXXXX000							
7	6	5	4	3	2	1	0
-	-	-	-	-	T0_OPERATING_MODE2	T0_OPERATING_MODE1	T0_OPERATING_MODE0
Bit	Name	Description					
7 - 3	-	Reserved.					
2 - 0	T0_OPERATING_MODE[2:0]	These bits control the T0 DPLL operating mode. 000: Automatic. (default) 001: Forced - Free-Run. 010: Forced - Holdover. 011: Reserved. 100: Forced - Locked. 101: Forced - Pre-Locked2. 110: Forced - Pre-Locked. 111: Forced - Lost-Phase.					

T4_OPERATING_MODE_CNFG - T4 DPLL Operating Mode Configuration

Address: 54H							
Type: Read / Write							
Default Value: XXXXX000							
7	6	5	4	3	2	1	0
-	-	-	-	-	T4_OPERATING_MODE2	T4_OPERATING_MODE1	T4_OPERATING_MODE0
Bit	Name	Description					
7 - 3	-	Reserved.					
2 - 0	T4_OPERATING_MODE[2:0]	These bits control the T4 DPLL operating mode. 000: Automatic. (default) 001: Forced - Free-Run. 010: Forced - Holdover. 011: Reserved. 100: Forced - Locked. 101, 110, 111: Reserved.					

7.2.7 T0 / T4 DPLL & APLL CONFIGURATION REGISTERS

T0_DPLL_APLL_PATH_CNFG - T0 DPLL & APLL Path Configuration

Address: 55H							
Type: Read / Write							
Default Value: 00000X0X							
7	6	5	4	3	2	1	0
T0_APLL_PATH 3	T0_APLL_PA TH2	T0_APLL_PA TH1	T0_APLL_PA TH0	T0_GSM_OBSAI_ 16E1_16T1_SEL1	T0_GSM_OBSAI_ 16E1_16T1_SELO	T0_12E1_24T1_ E3_T3_SEL1	T0_12E1_24T1_ E3_T3_SELO
Bit	Name	Description					
7 - 4	T0_APLL_PATH[3:0]	<p>These bits select an input to the T0 APLL.</p> <p>0000: The output of T0 DPLL 77.76 MHz path. (default)</p> <p>0001: The output of T0 DPLL 12E1/24T1/E3/T3 path.</p> <p>0010: The output of T0 DPLL 16E1/16T1 path.</p> <p>0011: The output of T0 DPLL GSM/OBSAI/16E1/16T1 path.</p> <p>0100: The output of T4 DPLL 77.76 MHz path.</p> <p>0101: The output of T4 DPLL 12E1/24T1/E3/T3 path.</p> <p>0110: The output of T4 DPLL 16E1/16T1 path.</p> <p>0111: The output of T4 DPLL GSM/GPS/16E1/16T1 path.</p> <p>1000: T0 ETH path.</p> <p>1100: T4 ETH path.</p> <p>1101~1111: Reserved.</p>					
3 - 2	T0_GSM_OBSAI_16E1_16T1_SEL[1:0]	<p>These bits select an output clock from the T0 DPLL GSM/OBSAI/16E1/16T1 path.</p> <p>00: 16E1.</p> <p>01: 16T1.</p> <p>10: GSM.</p> <p>11: OBSAI.</p> <p>The default value of the T0_GSM_OBSAI_16E1_16T1_SELO bit is determined by the SONET/SDH pin during reset.</p>					
1 - 0	T0_12E1_24T1_E3_T3_SEL[1:0]	<p>These bits select an output clock from the T0 DPLL 12E1/24T1/E3/T3 path.</p> <p>00: 12E1.</p> <p>01: 24T1.</p> <p>10: E3.</p> <p>11: T3.</p> <p>The default value of the T0_12E1_24T1_E3_T3_SELO bit is determined by the SONET/SDH pin during reset.</p>					

T0_DPLL_START_BW_DAMPING_CNFG - T0 DPLL Start Bandwidth & Damping Factor Configuration

Address: 56H							
Type: Read / Write							
Default Value: 01101111							
7	6	5	4	3	2	1	0
T0_DPLL_STA RT_DAMPING2	T0_DPLL_STA RT_DAMPING1	T0_DPLL_STA RT_DAMPING0	T0_DPLL_STA RT_BW4	T0_DPLL_STA RT_BW3	T0_DPLL_STA RT_BW2	T0_DPLL_STA RT_BW1	T0_DPLL_STA RT_BW0
Bit	Name	Description					
7 - 5	T0_DPLL_START_DAMPING[2:0]	These bits set the starting damping factor for T0 DPLL. 000: Reserved. 001: 1.2. 010: 2.5. 011: 5. (default) 100: 10. 101: 20. 110, 111: Reserved.					
4 - 0	T0_DPLL_START_BW[4:0]	These bits set the starting bandwidth for T0 DPLL. 00000: 0.5 MHz. 00001: 1 MHz. 00010: 2 MHz. 00011: 4 MHz. 00100: 8 MHz. 00101: 15 MHz. 00110: 30 MHz. 00111: 60 MHz. 01000: 0.1 Hz. 01001: 0.3 Hz. 01010: 0.6 Hz. 01011: 1.2 Hz. 01100: 2.5 Hz. 01101: 4 Hz. 01110: 8 Hz. 01111: 18 Hz. (default) 10000: 35 Hz. 10001: 70 Hz. 10010: 560 Hz. 10011 ~ 11111: Reserved.					

T0_DPLL_ACQ_BW_DAMPING_CNFG - T0 DPLL Acquisition Bandwidth & Damping Factor Configuration

Address: 57H
 Type: Read / Write
 Default Value: 01101111

7	6	5	4	3	2	1	0
T0_DPLL_ACQ_DAMPING2	T0_DPLL_ACQ_DAMPING1	T0_DPLL_ACQ_DAMPING0	T0_DPLL_ACQ_BW4	T0_DPLL_ACQ_BW3	T0_DPLL_ACQ_BW2	T0_DPLL_ACQ_BW1	T0_DPLL_ACQ_BW0

Bit	Name	Description
7 - 5	T0_DPLL_ACQ_DAMPING[2:0]	These bits set the acquisition damping factor for T0 DPLL. 000: Reserved. 001: 1.2. 010: 2.5. 011: 5. (default) 100: 10. 101: 20. 110, 111: Reserved.
4 - 0	T0_DPLL_ACQ_BW[4:0]	These bits set the acquisition bandwidth for T0 DPLL. 00000: 0.5 MHz. 00001: 1 MHz. 00010: 2 MHz. 00011: 4 MHz. 00100: 8 MHz. 00101: 15 MHz. 00110: 30 MHz. 00111: 60 MHz. 01000: 0.1 Hz. 01001: 0.3 Hz. 01010: 0.6 Hz. 01011: 1.2 Hz. 01100: 2.5 Hz. 01101: 4 Hz. 01110: 8 Hz. 01111: 18 Hz. (default) 10000: 35 Hz. 10001: 70 Hz. 10010: 560 Hz. 10011 ~ 11111: Reserved.

T0_DPLL_LOCKED_BW_DAMPING_CNFG - T0 DPLL Locked Bandwidth & Damping Factor Configuration

Address: 58H							
Type: Read / Write							
Default Value: 01101011							
7	6	5	4	3	2	1	0
T0_DPLL_LOCKED_DAMPING2	T0_DPLL_LOCKED_DAMPING1	T0_DPLL_LOCKED_DAMPING0	T0_DPLL_LOCKED_BW4	T0_DPLL_LOCKED_BW3	T0_DPLL_LOCKED_BW2	T0_DPLL_LOCKED_BW1	T0_DPLL_LOCKED_BW0
Bit	Name	Description					
7 - 5	T0_DPLL_LOCKED_DAMPING[2:0]	These bits set the locked damping factor for T0 DPLL. 000: Reserved. 001: 1.2. 010: 2.5. 011: 5. (default) 100: 10. 101: 20. 110, 111: Reserved.					
4 - 0	T0_DPLL_LOCKED_BW[4:0]	These bits set the locked bandwidth for T0 DPLL. 00000: 0.5 MHz. 00001: 1 MHz. 00010: 2 MHz. 00011: 4 MHz. 00100: 8 MHz. 00101: 15 MHz. 00110: 30 MHz. 00111: 60 MHz. 01000: 0.1 Hz. 01001: 0.3 Hz. 01010: 0.6 Hz. 01011: 1.2 Hz. (default) 01100: 2.5 Hz. 01101: 4 Hz. 01110: 8 Hz. 01111: 18 Hz. 10000: 35 Hz. 10001: 70 Hz. 10010: 560 Hz. 10011 ~ 11111: Reserved.					

T0_BW_OVERSHOOT_CNFG - T0 DPLL Bandwidth Overshoot Configuration

Address: 59H
 Type: Read / Write
 Default Value: 1XXX1XXX

7	6	5	4	3	2	1	0
AUTO_BW_SEL	-	-	-	T0_LIMT	-	-	-

Bit	Name	Description
7	AUTO_BW_SEL	This bit determines whether starting or acquisition bandwidth / damping factor is used for T0 DPLL. 0: The starting and acquisition bandwidths / damping factors are not used. Only the locked bandwidth / damping factor is used regardless of the T0 DPLL locking stage. 1: The starting, acquisition or locked bandwidth / damping factor is used automatically depending on different T0 DPLL locking stages. (default)
6 - 4	-	Reserved.
3	T0_LIMT	This bit determines whether the integral path value is frozen when the T0 DPLL hard limit is reached. 0: Not frozen. 1: Frozen. It will minimize the subsequent overshoot when T0 DPLL is pulling in. (default)
2 - 0	-	Reserved.

PHASE_LOSS_COARSE_LIMIT_CNFG - Phase Loss Coarse Detector Limit Configuration *

Address: 5AH																											
Type: Read / Write																											
Default Value: 10000101																											
7	6	5	4	3	2	1	0																				
COARSE_PH_LOS_LIMT_EN	WIDE_EN	MULTI_PH_APP	MULTI_PH_8K_4K_2K_EN	PH_LOS_COARSE_LIMT3	PH_LOS_COARSE_LIMT2	PH_LOS_COARSE_LIMT1	PH_LOS_COARSE_LIMT0																				
Bit	Name	Description																									
7	COARSE_PH_LOS_LIMT_EN	This bit controls whether the occurrence of the coarse phase loss will result in the T0/T4 DPLL being unlocked. 0: Disabled. 1: Enabled. (default)																									
6	WIDE_EN	Refer to the description of the MULTI_PH_8K_4K_2K_EN bit (b4, 5AH).																									
5	MULTI_PH_APP	This bit determines whether the PFD output of T0/T4 DPLL is limited to ± 1 UI or is limited to the coarse phase limit. 0: Limited to ± 1 UI. (default) 1: Limited to the coarse phase limit. When the selected input clock is of 2 kHz, 4 kHz or 8 kHz, the coarse phase limit depends on the MULTI_PH_8K_4K_2K_EN bit, the WIDE_EN bit and the PH_LOS_COARSE_LIMT[3:0] bits; when the selected input clock is of other frequencies than 2 kHz, 4 kHz and 8 kHz, the coarse phase limit depends on the WIDE_EN bit and the PH_LOS_COARSE_LIMT[3:0] bits. Refer to the description of the MULTI_PH_8K_4K_2K_EN bit (b4, 5AH) for details.																									
4	MULTI_PH_8K_4K_2K_EN	<p>This bit, together with the WIDE_EN bit (b6, 5AH) and the PH_LOS_COARSE_LIMT[3:0] bits (b3~0, 5AH), determines the coarse phase limit when the selected input clock is of 2 kHz, 4 kHz or 8 kHz. When the selected input clock is of other frequencies than 2 kHz, 4 kHz and 8 kHz, the coarse phase limit depends on the WIDE_EN bit and the PH_LOS_COARSE_LIMT[3:0] bits.</p> <table border="1" style="width: 100%; border-collapse: collapse;"> <thead> <tr> <th>Selected Input Clock</th> <th>MULTI_PH_8K_4K_2K_EN</th> <th>WIDE_EN</th> <th>Coarse Phase Limit</th> </tr> </thead> <tbody> <tr> <td></td> <td style="text-align: center;">0</td> <td style="text-align: center;">don't-care</td> <td style="text-align: center;">± 1 UI</td> </tr> <tr> <td rowspan="2" style="text-align: center;">2 kHz, 4 kHz or 8 kHz</td> <td rowspan="2" style="text-align: center;">1</td> <td style="text-align: center;">0</td> <td style="text-align: center;">± 1 UI</td> </tr> <tr> <td style="text-align: center;">1</td> <td style="text-align: center;">set by the PH_LOS_COARSE_LIMT[3:0] bits (b3~0, 5AH).</td> </tr> <tr> <td rowspan="2" style="text-align: center;">other than 2 kHz, 4 kHz and 8 kHz</td> <td rowspan="2" style="text-align: center;">don't-care</td> <td style="text-align: center;">0</td> <td style="text-align: center;">± 1 UI</td> </tr> <tr> <td style="text-align: center;">1</td> <td style="text-align: center;">set by the PH_LOS_COARSE_LIMT[3:0] bits (b3~0, 5AH).</td> </tr> </tbody> </table>						Selected Input Clock	MULTI_PH_8K_4K_2K_EN	WIDE_EN	Coarse Phase Limit		0	don't-care	± 1 UI	2 kHz, 4 kHz or 8 kHz	1	0	± 1 UI	1	set by the PH_LOS_COARSE_LIMT[3:0] bits (b3~0, 5AH).	other than 2 kHz, 4 kHz and 8 kHz	don't-care	0	± 1 UI	1	set by the PH_LOS_COARSE_LIMT[3:0] bits (b3~0, 5AH).
Selected Input Clock	MULTI_PH_8K_4K_2K_EN	WIDE_EN	Coarse Phase Limit																								
	0	don't-care	± 1 UI																								
2 kHz, 4 kHz or 8 kHz	1	0	± 1 UI																								
		1	set by the PH_LOS_COARSE_LIMT[3:0] bits (b3~0, 5AH).																								
other than 2 kHz, 4 kHz and 8 kHz	don't-care	0	± 1 UI																								
		1	set by the PH_LOS_COARSE_LIMT[3:0] bits (b3~0, 5AH).																								
3 - 0	PH_LOS_COARSE_LIMT[3:0]	<p>These bit set the coarse phase limit. The limit is used only in some cases. Refer to the description of the MULTI_PH_8K_4K_2K_EN bit (b4, 5AH).</p> <p>0000: ± 1 UI. 0001: ± 3 UI. 0010: ± 7 UI. 0011: ± 15 UI. 0100: ± 31 UI. 0101: ± 63 UI. (default) 0110: ± 127 UI. 0111: ± 255 UI. 1000: ± 511 UI. 1001: ± 1023 UI (T0); Reserved (T4). 1010-1111: Reserved.</p>																									

PHASE_LOSS_FINE_LIMIT_CNFG - Phase Loss Fine Detector Limit Configuration *

Address: 5BH							
Type: Read / Write							
Default Value: 10XXX010							
7	6	5	4	3	2	1	0
FINE_PH_LOS_LIMT_EN	FAST_LOS_SW	-	-	-	PH_LOS_FINE_LIMT2	PH_LOS_FINE_LIMT1	PH_LOS_FINE_LIMT0
Bit	Name	Description					
7	FINE_PH_LOS_LIMT_EN	This bit controls whether the occurrence of the fine phase loss will result in the T0/T4 DPLL being unlocked. 0: Disabled. 1: Enabled. (default)					
6	FAST_LOS_SW	The value in this bit can be switched only when it is available for T0 path; this bit is always '1' when it is available for T4 path. This bit controls whether the occurrence of the fast loss will result in the T0/T4 DPLL being unlocked. 0: Does not result in the T0 DPLL being unlocked. T0 DPLL will enter Temp-Holdover mode automatically. (default) 1: Results in the T0/T4 DPLL being unlocked. For T0 path, T0 DPLL will enter Lost-Phase mode if the T0 DPLL operating mode is switched automatically.					
5-3	-	Reserved.					
2-0	PH_LOS_FINE_LIMT[2:0]	These bits set a fine phase limit. 000: 0. 001: ± (45 ° ~ 90 °). 010: ± (90 ° ~ 180 °). (default) 011: ± (180 ° ~ 360 °). 100: ± (20 ns ~ 25 ns). 101: ± (60 ns ~ 65 ns). 110: ± (120 ns ~ 125 ns). 111: ± (950 ns ~ 955 ns).					

T0_HOLDOVER_MODE_CNFG - T0 DPLL Holdover Mode Configuration

Address: 5CH							
Type: Read / Write							
Default Value: 010001XX							
7	6	5	4	3	2	1	0
MAN_HOLDOVER	AUTO_AVG	FAST_AVG	READ_AVG	TEMP_HOLDOVER_MODE1	TEMP_HOLDOVER_MODE0	-	-
Bit	Name	Description					
7	MAN_HOLDOVER	Refer to the description of the FAST_AVG bit (b5, 5CH).					
6	AUTO_AVG	Refer to the description of the FAST_AVG bit (b5, 5CH).					
5	FAST_AVG	This bit, together with the AUTO_AVG bit (b6, 5CH) and the MAN_HOLDOVER bit (b7, 5CH), determines a frequency offset acquiring method in T0 DPLL Holdover Mode.					
		MAN_HOLDOVER	AUTO_AVG	FAST_AVG	Frequency Offset Acquiring Method		
		0	0	don't-care		Automatic Instantaneous	
			1	0	Automatic Slow Averaged (default)		
1	don't-care		1	Automatic Fast Averaged			
4	READ_AVG	This bit controls the holdover frequency offset reading, which is read from the T0_HOLDOVER_FREQ[23:0] bits (5FH ~ 5DH).					
		0: The value read from the T0_HOLDOVER_FREQ[23:0] bits (5FH ~ 5DH) is equal to the one written to them. (default) 1: The value read from the T0_HOLDOVER_FREQ[23:0] bits (5FH ~ 5DH) is not equal to the one written to them. The value is acquired by Automatic Slow Averaged method if the FAST_AVG bit (b5, 5CH) is '0'; or is acquired by Automatic Fast Averaged method if the FAST_AVG bit (b5, 5CH) is '1'.					
3 - 2	TEMP_HOLDOVER_MODE[1:0]	These bits determine the frequency offset acquiring method in T0 DPLL Temp-Holdover Mode. 00: The method is the same as that used in T0 DPLL Holdover mode. 01: Automatic Instantaneous. (default) 10: Automatic Fast Averaged. 11: Automatic Slow Averaged.					
1 - 0	-	Reserved.					

T0_HOLDOVER_FREQ[7:0]_CNFG - T0 DPLL Holdover Frequency Configuration 1

Address: 5DH							
Type: Read / Write							
Default Value: 00000000							
7	6	5	4	3	2	1	0
T0_HOLDOVER_FREQ7	T0_HOLDOVER_FREQ6	T0_HOLDOVER_FREQ5	T0_HOLDOVER_FREQ4	T0_HOLDOVER_FREQ3	T0_HOLDOVER_FREQ2	T0_HOLDOVER_FREQ1	T0_HOLDOVER_FREQ0
Bit	Name	Description					
7 - 0	T0_HOLDOVER_FREQ[7:0]	Refer to the description of the T0_HOLDOVER_FREQ[23:16] bits (b7~0, 5FH).					

T0_HOLDOVER_FREQ[15:8]_CNFG - T0 DPLL Holdover Frequency Configuration 2

Address: 5EH							
Type: Read / Write							
Default Value: 00000000							
7	6	5	4	3	2	1	0
T0_HOLDOVER_FREQ15	T0_HOLDOVER_FREQ14	T0_HOLDOVER_FREQ13	T0_HOLDOVER_FREQ12	T0_HOLDOVER_FREQ11	T0_HOLDOVER_FREQ10	T0_HOLDOVER_FREQ9	T0_HOLDOVER_FREQ8
Bit	Name	Description					
7 - 0	T0_HOLDOVER_FREQ[15:8]	Refer to the description of the T0_HOLDOVER_FREQ[23:16] bits (b7~0, 5FH).					

T0_HOLDOVER_FREQ[23:16]_CNFG - T0 DPLL Holdover Frequency Configuration 3

Address: 5FH							
Type: Read / Write							
Default Value: 00000000							
7	6	5	4	3	2	1	0
T0_HOLDOVER_FREQ23	T0_HOLDOVER_FREQ22	T0_HOLDOVER_FREQ21	T0_HOLDOVER_FREQ20	T0_HOLDOVER_FREQ19	T0_HOLDOVER_FREQ18	T0_HOLDOVER_FREQ17	T0_HOLDOVER_FREQ16
Bit	Name	Description					
7 - 0	T0_HOLDOVER_FREQ[23:16]	The T0_HOLDOVER_FREQ[23:0] bits represent a 2's complement signed integer. In T0 DPLL Holdover mode, the value written to these bits multiplied by 0.000011 is the frequency offset set manually; the value read from these bits multiplied by 0.000011 is the frequency offset automatically slow or fast averaged or manually set, as determined by the READ_AVG bit (b4, 5CH) and the FAST_AVG bit (b5, 5CH).					

T4_DPLL_APLL_PATH_CNFG - T4 DPLL & APLL Path Configuration

Address: 60H							
Type: Read / Write							
Default Value: 01000X0X							
7	6	5	4	3	2	1	0
T4_APLL_PATH 3	T4_APLL_PA TH2	T4_APLL_PA TH1	T4_APLL_PA TH0	T4_GSM_GPS_16 E1_16T1_SEL1	T4_GSM_GPS_16 E1_16T1_SELO	T4_12E1_24T1_ E3_T3_SEL1	T4_12E1_24T1_ E3_T3_SELO
Bit	Name	Description					
7 - 4	T4_APLL_PATH[3:0]	These bits select an input to the T4 APLL. 0000: The output of T0 DPLL 77.76 MHz path. 0001: The output of T0 DPLL 12E1/24T1/E3/T3 path. 0010: The output of T0 DPLL 16E1/16T1 path. 0011: The output of T0 DPLL GSM/OBSAI/16E1/16T1 path. 0100: The output of T4 DPLL 77.76 MHz path. (default) 0101: The output of T4 DPLL 12E1/24T1/E3/T3 path. 0110: The output of T4 DPLL 16E1/16T1 path. 0111: The output of T4 DPLL GSM/GPS/16E1/16T1 path. 1000: T0 ETH path. 1100: T4 ETH path. 1101~1111: Reserved.					
3 - 2	T4_GSM_GPS_16E1_16T1_SEL[1:0]	These bits select an output clock from the T4 DPLL GSM/GPS/16E1/16T1 path. 00: 16E1. 01: 16T1. 10: GSM. 11: GPS. The default value of the T0_GSM_GPS_16E1_16T1_SELO bit is determined by the SONET/SDH pin during reset.					
1 - 0	T4_12E1_24T1_E3_T3_SEL[1:0]	These bits select an output clock from the T4 DPLL 12E1/24T1/E3/T3 path. 00: 12E1. 01: 24T1. 10: E3. 11: T3. The default value of the T4_12E1_24T1_E3_T3_SELO bit is determined by the SONET/SDH pin during reset.					

T4_DPLL_LOCKED_BW_DAMPING_CNFG - T4 DPLL Locked Bandwidth & Damping Factor Configuration

Address: 61H
Type: Read / Write
Default Value: 011XXX00

7	6	5	4	3	2	1	0
T4_DPLL_LOCKED_DAMPING2	T4_DPLL_LOCKED_DAMPING1	T4_DPLL_LOCKED_DAMPING0	-	-	-	T4_DPLL_LOCKED_BW1	T4_DPLL_LOCKED_BW0

Bit	Name	Description
7 - 5	T4_DPLL_LOCKED_DAMPING[2:0]	These bits set the locked damping factor for T4 DPLL. 000: Reserved. 001: 1.2. 010: 2.5. 011: 5. (default) 100: 10. 101: 20. 110, 111: Reserved.
4 - 2	-	Reserved.
1 - 0	T4_DPLL_LOCKED_BW[1:0]	These bits set the locked bandwidth for T4 DPLL. 00: 18 Hz. (default) 01: 35 Hz. 10: 70 Hz. 11: 560 Hz.

CURRENT_DPLL_FREQ[7:0]_STS - DPLL Current Frequency Status 1 *

Address: 62H
Type: Read
Default Value: 00000000

7	6	5	4	3	2	1	0
CURRENT_DPLL_FREQ7	CURRENT_DPLL_FREQ6	CURRENT_DPLL_FREQ5	CURRENT_DPLL_FREQ4	CURRENT_DPLL_FREQ3	CURRENT_DPLL_FREQ2	CURRENT_DPLL_FREQ1	CURRENT_DPLL_FREQ0

Bit	Name	Description
7 - 0	CURRENT_DPLL_FREQ[7:0]	Refer to the description of the CURRENT_DPLL_FREQ[23:16] bits (b7~0, 64H).

CURRENT_DPLL_FREQ[15:8]_STS - DPLL Current Frequency Status 2 *

Address: 63H
Type: Read
Default Value: 00000000

7	6	5	4	3	2	1	0
CURRENT_DPLL_FREQ15	CURRENT_DPLL_FREQ14	CURRENT_DPLL_FREQ13	CURRENT_DPLL_FREQ12	CURRENT_DPLL_FREQ11	CURRENT_DPLL_FREQ10	CURRENT_DPLL_FREQ9	CURRENT_DPLL_FREQ8

Bit	Name	Description
7 - 0	CURRENT_DPLL_FREQ[15:8]	Refer to the description of the CURRENT_DPLL_FREQ[23:16] bits (b7~0, 64H).

CURRENT_DPLL_FREQ[23:16]_STS - DPLL Current Frequency Status 3 *

Address: 64H Type: Read Default Value: 00000000							
7	6	5	4	3	2	1	0
CURRENT_DPLL_FREQ23	CURRENT_DPLL_FREQ22	CURRENT_DPLL_FREQ21	CURRENT_DPLL_FREQ20	CURRENT_DPLL_FREQ19	CURRENT_DPLL_FREQ18	CURRENT_DPLL_FREQ17	CURRENT_DPLL_FREQ16
Bit	Name	Description					
7 - 0	CURRENT_DPLL_FREQ[23:16]	The CURRENT_DPLL_FREQ[23:0] bits represent a 2's complement signed integer. If the value in these bits is multiplied by 0.000011, the current frequency offset of the T0/T4 DPLL output in ppm with respect to the master clock will be gotten.					

DPLL_FREQ_SOFT_LIMIT_CNFG - DPLL Soft Limit Configuration

Address: 65H Type: Read / Write Default Value: 10001100							
7	6	5	4	3	2	1	0
FREQ_LIMIT_PH_LOS	DPLL_FREQ_SOFT_LIMIT6	DPLL_FREQ_SOFT_LIMIT5	DPLL_FREQ_SOFT_LIMIT4	DPLL_FREQ_SOFT_LIMIT3	DPLL_FREQ_SOFT_LIMIT2	DPLL_FREQ_SOFT_LIMIT1	DPLL_FREQ_SOFT_LIMIT0
Bit	Name	Description					
7	FREQ_LIMIT_PH_LOS	This bit determines whether the T0/T4 DPLL in hard alarm status will result in its being unlocked. 0: Disabled. 1: Enabled. (default)					
6 - 0	DPLL_FREQ_SOFT_LIMIT[6:0]	These bits represent an unsigned integer. If the value is multiplied by 0.724, the DPLL soft limit for T0 and T4 paths in ppm will be gotten. The DPLL soft limit is symmetrical about zero.					

DPLL_FREQ_HARD_LIMIT[7:0]_CNFG - DPLL Hard Limit Configuration 1

Address: 66H Type: Read / Write Default Value: 10101011							
7	6	5	4	3	2	1	0
DPLL_FREQ_HARD_LIMIT7	DPLL_FREQ_HARD_LIMIT6	DPLL_FREQ_HARD_LIMIT5	DPLL_FREQ_HARD_LIMIT4	DPLL_FREQ_HARD_LIMIT3	DPLL_FREQ_HARD_LIMIT2	DPLL_FREQ_HARD_LIMIT1	DPLL_FREQ_HARD_LIMIT0
Bit	Name	Description					
7 - 0	DPLL_FREQ_HARD_LIMIT[7:0]	Refer to the description of the DPLL_FREQ_HARD_LIMIT[15:8] bits (b7~0, 67H).					

DPLL_FREQ_HARD_LIMIT[15:8]_CNFG - DPLL Hard Limit Configuration 2

Address: 67H Type: Read / Write Default Value: 00011001							
7	6	5	4	3	2	1	0
DPLL_FREQ_H ARD_LIMIT15	DPLL_FREQ_H ARD_LIMIT14	DPLL_FREQ_H ARD_LIMIT13	DPLL_FREQ_H ARD_LIMIT12	DPLL_FREQ_H ARD_LIMIT11	DPLL_FREQ_H ARD_LIMIT10	DPLL_FREQ_H ARD_LIMIT9	DPLL_FREQ_H ARD_LIMIT8
Bit	Name	Description					
7 - 0	DPLL_FREQ_HARD_LIMIT[15:8]	The DPLL_FREQ_HARD_LIMIT[15:0] bits represent an unsigned integer. If the value is multiplied by 0.0014, the DPLL hard limit for T0 and T4 paths in ppm will be gotten. The DPLL hard limit is symmetrical about zero.					

CURRENT_DPLL_PHASE[7:0]_STS - DPLL Current Phase Status 1 *

Address: 68H Type: Read Default Value: 00000000							
7	6	5	4	3	2	1	0
CURRENT_PH _DATA7	CURRENT_PH _DATA6	CURRENT_PH _DATA5	CURRENT_PH _DATA4	CURRENT_PH _DATA3	CURRENT_PH _DATA2	CURRENT_PH _DATA1	CURRENT_PH _DATA0
Bit	Name	Description					
7 - 0	CURRENT_PH_DATA[7:0]	Refer to the description of the CURRENT_PH_DATA[15:8] bits (b7~0, 69H).					

CURRENT_DPLL_PHASE[15:8]_STS - DPLL Current Phase Status 2 *

Address: 69H Type: Read Default Value: 00000000							
7	6	5	4	3	2	1	0
CURRENT_PH _DATA15	CURRENT_PH _DATA14	CURRENT_PH _DATA13	CURRENT_PH _DATA12	CURRENT_PH _DATA11	CURRENT_PH _DATA10	CURRENT_PH _DATA9	CURRENT_PH _DATA8
Bit	Name	Description					
7 - 0	CURRENT_PH_DATA[15:8]	The CURRENT_PH_DATA[15:0] bits represent a 2's complement signed integer. If the value is multiplied by 0.61, the averaged phase error of the T0/T4 DPLL feedback with respect to the selected input clock in ns will be gotten.					

T0_T4_APLL_BW_CNFG - T0 / T4 APLL Bandwidth Configuration

Address: 6AH
 Type: Read / Write
 Default Value: 10011011

7	6	5	4	3	2	1	0
-	-	T0_APLL_BW2	T0_APLL_BW1	T0_APLL_BW0	T4_APLL_BW2	T4_APLL_BW1	T4_APLL_BW0

Bit	Name	Description
7 - 6	-	Reserved.
5 - 3	T0_APLL_BW[2:0]	These bits set the bandwidth for T0 APLL. 000 - 010: Reserved 011: 100 KHz. 100: 200 KHz. 101: 500 KHz. 110: 1 MHz. 111: 2 MHz.
2 - 0	T4_APLL_BW[2:0]	These bits set the bandwidth for T4 APLL. 000 - 010: Reserved 011: 100 KHz. 100: 200 KHz. 101: 500 KHz. 110: 1 MHz. 111: 2 MHz.

7.2.8 OUTPUT CONFIGURATION REGISTERS

OUT1_FREQ_CNFG - Output Clock 1 Frequency Configuration

Address: 6DH							
Type: Read / Write							
Default Value: 00001000							
7	6	5	4	3	2	1	0
OUT1_PATH_S EL3	OUT1_PATH_S EL2	OUT1_PATH_S EL1	OUT1_PATH_S EL0	OUT1_DIVIDER 3	OUT1_DIVIDER 2	OUT1_DIVIDER 1	OUT1_DIVIDER 0
Bit	Name	Description					
7 - 4	OUT1_PATH_SEL[3:0]	<p>These bits select an input to OUT1.</p> <p>0000 ~ 0010: The output of T0 APLL. (default: 0000)</p> <p>0011: T0 DPLL ETH path.</p> <p>0100: The output of T0 DPLL 77.76 MHz path.</p> <p>0101: The output of T0 DPLL 12E1/24T1/E3/T3 path.</p> <p>0110: The output of T0 DPLL 16E1/16T1 path.</p> <p>0111: The output of T0 DPLL GSM/OBSAI/16E1/16T1 path.</p> <p>1000 ~ 1010: The output of T4 APLL.</p> <p>1011: T4 DPLL ETH path.</p> <p>1100: The output of T4 DPLL 77.76 MHz path.</p> <p>1101: The output of T4 DPLL 12E1/24T1/E3/T3 path.</p> <p>1110: The output of T4 DPLL 16E1/16T1 path.</p> <p>1111: The output of T4 DPLL GSM/GPS/16E1/16T1 path.</p>					
3 - 0	OUT1_DIVIDER[3:0]	<p>These bits select a division factor of the divider for OUT1.</p> <p>The output frequency is determined by the division factor and the signal derived from T0/T4 DPLL or T0/T4 APLL output (selected by the OUT1_PATH_SEL[3:0] bits (b7~4, 6DH)). If the signal is derived from one of the T0/T4 DPLL outputs, please refer to Table 24 for the division factor selection. If the signal is derived from the T0/T4 APLL output, please refer to Table 25 for the division factor selection.</p>					

OUT2_FREQ_CNFG - Output Clock 2 Frequency Configuration

Address: 6EH							
Type: Read / Write							
Default Value: 00000110							
7	6	5	4	3	2	1	0
OUT2_PATH_S EL3	OUT2_PATH_S EL2	OUT2_PATH_S EL1	OUT2_PATH_S EL0	OUT2_DIVIDER 3	OUT2_DIVIDER 2	OUT2_DIVIDER 1	OUT2_DIVIDER 0
Bit	Name	Description					
7 - 4	OUT2_PATH_SEL[3:0]	<p>These bits select an input to OUT2.</p> <p>0000 ~ 0010: The output of T0 APLL. (default: 0000)</p> <p>0011: T0 DPLL ETH path.</p> <p>0100: The output of T0 DPLL 77.76 MHz path.</p> <p>0101: The output of T0 DPLL 12E1/24T1/E3/T3 path.</p> <p>0110: The output of T0 DPLL 16E1/16T1 path.</p> <p>0111: The output of T0 DPLL GSM/OBSAI/16E1/16T1 path.</p> <p>1000 ~ 1010: The output of T4 APLL.</p> <p>1011: T4 DPLL ETH path.</p> <p>1100: The output of T4 DPLL 77.76 MHz path.</p> <p>1101: The output of T4 DPLL 12E1/24T1/E3/T3 path.</p> <p>1110: The output of T4 DPLL 16E1/16T1 path.</p> <p>1111: The output of T4 DPLL GSM/GPS/16E1/16T1 path.</p>					
3 - 0	OUT2_DIVIDER[3:0]	<p>These bits select a division factor of the divider for OUT2.</p> <p>The output frequency is determined by the division factor and the signal derived from T0/T4 DPLL or T0/T4 APLL output (selected by the OUT2_PATH_SEL[3:0] bits (b7~4, 6EH)). If the signal is derived from one of the T0/T4 DPLL outputs, please refer to Table 24 for the division factor selection. If the signal is derived from the T0/T4 APLL output, please refer to Table 25 for the division factor selection.</p>					

OUT3_FREQ_CNFG - Output Clock 3 Frequency Configuration

Address: 6FH							
Type: Read / Write							
Default Value: 00000100							
7	6	5	4	3	2	1	0
OUT3_PATH_S EL3	OUT3_PATH_S EL2	OUT3_PATH_S EL1	OUT3_PATH_S EL0	OUT3_DIVIDER 3	OUT3_DIVIDER 2	OUT3_DIVIDER 1	OUT3_DIVIDER 0
Bit	Name	Description					
7 - 4	OUT3_PATH_SEL[3:0]	<p>These bits select an input to OUT3.</p> <p>0000 ~ 0010: The output of T0 APLL. (default: 0000)</p> <p>0011: T0 DPLL ETH path.</p> <p>0100: The output of T0 DPLL 77.76 MHz path.</p> <p>0101: The output of T0 DPLL 12E1/24T1/E3/T3 path.</p> <p>0110: The output of T0 DPLL 16E1/16T1 path.</p> <p>0111: The output of T0 DPLL GSM/OBSAI/16E1/16T1 path.</p> <p>1000 ~ 1010: The output of T4 APLL.</p> <p>1011: T4 DPLL ETH path.</p> <p>1100: The output of T4 DPLL 77.76 MHz path.</p> <p>1101: The output of T4 DPLL 12E1/24T1/E3/T3 path.</p> <p>1110: The output of T4 DPLL 16E1/16T1 path.</p> <p>1111: The output of T4 DPLL GSM/GPS/16E1/16T1 path.</p>					
3 - 0	OUT3_DIVIDER[3:0]	<p>These bits select a division factor of the divider for OUT3.</p> <p>The output frequency is determined by the division factor and the signal derived from T0/T4 DPLL or T0/T4 APLL output (selected by the OUT3_PATH_SEL[3:0] bits (b7~4, 6FH)). If the signal is derived from one of the T0/T4 DPLL outputs, please refer to Table 24 for the division factor selection. If the signal is derived from the T0/T4 APLL output, please refer to Table 25 for the division factor selection.</p>					

OUT4_FREQ_CNFG - Output Clock 4 Frequency Configuration

Address: 70H							
Type: Read / Write							
Default Value: 00000110							
7	6	5	4	3	2	1	0
OUT4_PATH_S EL3	OUT4_PATH_S EL2	OUT4_PATH_S EL1	OUT4_PATH_S EL0	OUT4_DIVIDER 3	OUT4_DIVIDER 2	OUT4_DIVIDER 1	OUT4_DIVIDER 0
Bit	Name	Description					
7 - 4	OUT4_PATH_SEL[3:0]	<p>These bits select an input to OUT4.</p> <p>0000 ~ 0010: The output of T0 APLL. (default: 0000)</p> <p>0011: T0 DPLL ETH path.</p> <p>0100: The output of T0 DPLL 77.76 MHz path.</p> <p>0101: The output of T0 DPLL 12E1/24T1/E3/T3 path.</p> <p>0110: The output of T0 DPLL 16E1/16T1 path.</p> <p>0111: The output of T0 DPLL GSM/OBSAI/16E1/16T1 path.</p> <p>1000 ~ 1010: The output of T4 APLL.</p> <p>1011: T4 DPLL ETH path.</p> <p>1100: The output of T4 DPLL 77.76 MHz path.</p> <p>1101: The output of T4 DPLL 12E1/24T1/E3/T3 path.</p> <p>1110: The output of T4 DPLL 16E1/16T1 path.</p> <p>1111: The output of T4 DPLL GSM/GPS/16E1/16T1 path.</p>					
3 - 0	OUT4_DIVIDER[3:0]	<p>These bits select a division factor of the divider for OUT4.</p> <p>The output frequency is determined by the division factor and the signal derived from T0/T4 DPLL or T0/T4 APLL output (selected by the OUT4_PATH_SEL[3:0] bits (b7~4, 70H)). If the signal is derived from one of the T0/T4 DPLL outputs, please refer to Table 24 for the division factor selection. If the signal is derived from the T0/T4 APLL output, please refer to Table 25 for the division factor selection.</p>					

OUT5_FREQ_CNFG - Output Clock 5 Frequency Configuration

Address:71H Type: Read / Write Default Value: 00001000							
7	6	5	4	3	2	1	0
OUT5_PATH_S EL3	OUT5_PATH_S EL2	OUT5_PATH_S EL1	OUT5_PATH_S EL0	OUT5_DIVIDER 3	OUT5_DIVIDER 2	OUT5_DIVIDER 1	OUT5_DIVIDER 0
Bit	Name	Description					
7 - 4	OUT5_PATH_SEL[3:0]	These bits select an input to OUT5. 0000 ~ 0010: The output of T0 APLL. (default: 0000) 0011: T0 DPLL ETH path. 0100: The output of T0 DPLL 77.76 MHz path. 0101: The output of T0 DPLL 12E1/24T1/E3/T3 path. 0110: The output of T0 DPLL 16E1/16T1 path. 0111: The output of T0 DPLL GSM/OBSAI/16E1/16T1 path. 1000 ~ 1010: The output of T4 APLL. 1011: T4 DPLL ETH path. 1100: The output of T4 DPLL 77.76 MHz path. 1101: The output of T4 DPLL 12E1/24T1/E3/T3 path. 1110: The output of T4 DPLL 16E1/16T1 path. 1111: The output of T4 DPLL GSM/GPS/16E1/16T1 path.					
3 - 0	OUT5_DIVIDER[3:0]	These bits select a division factor of the divider for OUT5. The output frequency is determined by the division factor and the signal derived from T0/T4 DPLL or T0/T4 APLL output (selected by the OUT5_PATH_SEL[3:0] bits (b7~4, 71H)). If the signal is derived from one of the T0/T4 DPLL outputs, please refer to Table 24 for the division factor selection. If the signal is derived from the T0/T4 APLL output, please refer to Table 25 for the division factor selection.					

OUTPUT_INV2 - Output Clock 4 & 5 Invert Configuration

Address:72H Type: Read / Write Default Value: 01000000							
7	6	5	4	3	2	1	0
-	-	-	-	-	-	OUT5_INV	OUT4_INV
Bit	Name	Description					
7 - 2	-	Reserved.					
1	OUT5_INV	This bit determines whether the output on OUT5 is inverted. 0: Not inverted. (default) 1: Inverted.					
0	OUT4_INV	This bit determines whether the output on OUT4 is inverted. 0: Not inverted. (default) 1: Inverted.					

OUTPUT_INV1 - Output Clock 1 ~ 3 Invert Configuration

Address: 73H
 Type: Read / Write
 Default Value: 01000000

7	6	5	4	3	2	1	0
-	-	-	OUT3_INV	OUT2_INV	OUT1_INV	-	-

Bit	Name	Description
7 - 5	-	Reserved.
4	OUT3_INV	This bit determines whether the output on OUT3 is inverted. 0: Not inverted. (default) 1: Inverted.
3	OUT2_INV	This bit determines whether the output on OUT2 is inverted. 0: Not inverted. (default) 1: Inverted.
2	OUT1_INV	This bit determines whether the output on OUT1 is inverted. 0: Not inverted. (default) 1: Inverted.
1 - 0	-	Reserved.

IDT CONFIDENTIAL

FR_MFR_SYNC_CNFG - Frame Sync & Multiframe Sync Output Configuration

Address:74H							
Type: Read / Write							
Default Value: 01100000							
7	6	5	4	3	2	1	0
IN_2K_4K_8K_I NV	8K_EN	2K_EN	2K_8K_PUL_P OSITION	8K_INV	8K_PUL	2K_INV	2K_PUL
Bit	Name	Description					
7	IN_2K_4K_8K_INV	This bit determines whether the input clock is inverted before locked by the T0/T4 DPLL when the input clock is 2 kHz, 4 kHz or 8 kHz. 0: Not inverted. (default) 1: Inverted.					
6	8K_EN	This bit determines whether an 8 kHz signal is enabled to be output on FRSYNC_8K. 0: Disabled. FRSYNC_8K outputs low. 1: Enabled. (default)					
5	2K_EN	This bit determines whether a 2 kHz signal is enabled to be output on MFRSYNC_2K. 0: Disabled. MFRSYNC_2K outputs low. 1: Enabled. (default)					
4	2K_8K_PUL_POSITION	This bit is valid only when FRSYNC_8K and/or MFRSYNC_2K output pulse; i.e., when one of the 8K_PUL bit (b2, 74H) and the 2K_PUL bit (b0, 74H) is '1' or when the 8K_PUL bit (b2, 74H) and the 2K_PUL bit (b0, 74H) are both '1'. It determines the pulse position referring to the standard 50:50 duty cycle. 0: Pulsed on the falling edge of the standard 50:50 duty cycle position. (default) 1: Pulsed on the rising edge of the standard 50:50 duty cycle position.					
3	8K_INV	This bit determines whether the output on FRSYNC_8K is inverted. 0: Not inverted. (default) 1: Inverted.					
2	8K_PUL	This bit determines whether the output on FRSYNC_8K is 50:50 duty cycle or pulsed. 0: 50:50 duty cycle. (default) 1: Pulsed. The pulse width is defined by the period of the output on OUT1.					
1	2K_INV	This bit determines whether the output on MFRSYNC_2K is inverted. 0: Not inverted. (default) 1: Inverted.					
0	2K_PUL	This bit determines whether the output on MFRSYNC_2K is 50:50 duty cycle or pulsed. 0: 50:50 duty cycle. (default) 1: Pulsed. The pulse width is defined by the period of the output on OUT1.					

7.2.9 PBO & PHASE OFFSET CONTROL REGISTERS

PHASE_MON_PBO_CNFG - Phase Transient Monitor & PBO Configuration

Address:78H							
Type: Read / Write							
Default Value: 0X000110							
7	6	5	4	3	2	1	0
IN_NOISE_WIN DOW	-	PH_MON_EN	PH_MON_PBO _EN	PH_TR_MON_L IMT3	PH_TR_MON_L IMT2	PH_TR_MON_L IMT1	PH_TR_MON_L IMT0
Bit	Name	Description					
7	IN_NOISE_WINDOW	This bit determines whether the input clock whose edge respect to the reference clock is outside $\pm 5\%$ is enabled to be selected for T0/T4 DPLL. 0: Disabled. (default) 1: Enabled.					
6	-	Reserved.					
5	PH_MON_EN	This bit is valid only when the PH_MON_PBO_EN bit (b4, 78H) is '1'. It determines whether the Phase Transient Monitor is enabled to monitor the phase changes on the T0 selected input clock. 0: Disabled. (default) 1: Enabled.					
4	PH_MON_PBO_EN	This bit determines whether a PBO event is triggered when the phase changes on the T0 selected input clock are greater than a programmable limit over an interval of less than 0.1 seconds with the PH_MON_EN bit being '1'. The limit is programmed by the PH_TR_MON_LIMT[3:0] bits (b3~0, 78H). 0: Disabled. (default) 1: Enabled.					
3 - 0	PH_TR_MON_LIMT[3:0]	These bits represent an unsigned integer. The Phase Transient Monitor limit in ns can be calculated as follows: Limit (ns) = (PH_TR_MON_LIMT[3:0] + 7) X 156.					

PHASE_OFFSET[7:0]_CNFG - Phase Offset Configuration 1

Address:7AH							
Type: Read / Write							
Default Value: 00000000							
7	6	5	4	3	2	1	0
PH_OFFSET7	PH_OFFSET6	PH_OFFSET5	PH_OFFSET4	PH_OFFSET3	PH_OFFSET2	PH_OFFSET1	PH_OFFSET0
Bit	Name	Description					
7 - 0	PH_OFFSET[7:0]	Refer to the description of the PH_OFFSET[9:8] bits (b1~0, 7BH).					

PHASE_OFFSET[9:8]_CNFG - Phase Offset Configuration 2

Address: 7BH							
Type: Read / Write							
Default Value: 0XXXXX00							
7	6	5	4	3	2	1	0
PH_OFFSET_EN	-	-	-	-	-	PH_OFFSET9	PH_OFFSET8
Bit	Name	Description					
7	PH_OFFSET_EN	This bit determines whether the input-to-output phase offset is enabled. If the device is configured as the Master, the input-to-output phase offset: 0: Disabled. (default) 1: Enabled. If the device is configured as the Slave, the input-to-output phase offset is always enabled.					
6 - 2	-	Reserved.					
1 - 0	PH_OFFSET[9:8]	These bits represent a 2's complement signed integer. If the value is multiplied by 0.61, the input-to-output phase offset in ns to adjust will be gotten.					

7.2.10 SYNCHRONIZATION CONFIGURATION REGISTERS

SYNC_MONITOR_CNFG - Sync Monitor Configuration

Address:7CH
 Type: Read / Write
 Default Value: X0101011

7	6	5	4	3	2	1	0
-	SYNC_MON_LIMT2	SYNC_MON_LIMT1	SYNC_MON_LIMT0	-	-	-	-

Bit	Name	Description
7	-	Reserved.
6 - 4	SYNC_MON_LIMT[2:0]	These bits set the limit for the external sync alarm. 000: ±1 UI. 001: ±2 UI. 010: ±3 UI. (default) 011: ±4 UI. 100: ±5 UI. 101: ±6 UI. 110: ±7 UI. 111: ±8 UI.
3 - 0	-	These bits must be set to '1011'.

SYNC_PHASE_CNFG - Sync Phase Configuration

Address:7DH
 Type: Read / Write
 Default Value: XXXXXX00

7	6	5	4	3	2	1	0
-	-	-	-	-	-	SYNC_PH11	SYNC_PH10

Bit	Name	Description
7 - 2	-	Reserved.
1 - 0	SYNC_PH1[1:0]	These bits set the sampling of EX_SYNC1 when EX_SYNC1 is enabled to synchronize the frame sync output signal. Nominally, the falling edge of EX_SYNC1 is aligned with the rising edge of the T0 selected input clock. 00: On target. (default) 01: 0.5 UI early. 10: 1 UI late. 11: 0.5 UI late.

8 THERMAL MANAGEMENT

The device operates over the industry temperature range -40°C ~ +85°C. To ensure the functionality and reliability of the device, the maximum junction temperature T_{jmax} should not exceed 125°C. In some applications, the device will consume more power and a thermal solution should be provided to ensure the junction temperature T_j does not exceed the T_{jmax} .

8.1 JUNCTION TEMPERATURE

Junction temperature T_j is the temperature of package typically at the geographical center of the chip where the device's electrical circuits are. It can be calculated as follows:

$$\text{Equation 1: } T_j = T_A + P \times \theta_{JA}$$

Where:

θ_{JA} = Junction-to-Ambient Thermal Resistance of the Package

T_j = Junction Temperature

T_A = Ambient Temperature

P = Device Power Consumption

In order to calculate junction temperature, an appropriate θ_{JA} must be used. The θ_{JA} is shown in Table 44.

Power consumption is the core power excluding the power dissipated in the loads. Table 43 provides power consumption in special environments.

Table 43: Power Consumption and Maximum Junction Temperature

Package	Power Consumption (W)	Operating Voltage (V)	T_A (°C)	Maximum Junction Temperature (°C)
TQFP 100	1.9	3.6	85	125
TQFP/EQG100	1.9	3.6	85	125

8.2 EXAMPLE OF JUNCTION TEMPERATURE CALCULATION

Assume:

$$T_A = 85^\circ\text{C}$$

$$\theta_{JA} = 18.9^\circ\text{C/W (TQFP/EQG100 Soldered \& when airflow rate is 0 m/s)}$$

$$P = 1.9\text{W}$$

Table 44: Thermal Data

Package	Pin Count	Thermal Pad	θ_{JC} (°C/W)	θ_{JB} (°C/W)	θ_{JA} (°C/W) vs Air Flow in m/s					
					0	1	2	3	4	5
TQFP100	100	No	11.0	34.2	39.3	36.2	34.3	33.5	32.9	32.6
TQFP/EQG100	100	Yes/Exposed	16.1	34.2	35.8	31.1	29.5	28.6	27.9	27.4
TQFP/EQG100	100	Yes/Soldered*	16.1	1.3	18.9	14.6	13.5	12.9	12.6	12.4

*note: Simulated with 3 x 3 array of thermal vias.

The junction temperature T_j can be calculated as follows:

$$T_j = T_A + P \times \theta_{JA} = 85^\circ\text{C} + 1.9\text{W} \times 18.9^\circ\text{C/W} = 120.9^\circ\text{C}$$

The junction temperature of 120.9°C is below the maximum junction temperature of 125°C so no extra heat enhancement is required.

In some operation environments, the calculated junction temperature might exceed the maximum junction temperature of 125°C and an external thermal solution such as a heatsink is required.

8.3 HEATSINK EVALUATION

A heatsink is expanding the surface area of the device to which it is attached. θ_{JA} is now a combination of device case and heat-sink thermal resistance, as the heat flowing from the die junction to ambient goes through the package and the heatsink. θ_{JA} can be calculated as follows:

$$\text{Equation 2: } \theta_{JA} = \theta_{JC} + \theta_{CH} + \theta_{HA}$$

Where:

θ_{JC} = Junction-to-Case Thermal Resistance

θ_{CH} = Case-to-Heatsink Thermal Resistance

θ_{HA} = Heatsink-to-Ambient Thermal Resistance

$\theta_{CH} + \theta_{HA}$ determines which heatsink and heatsink attachment can be selected to ensure the junction temperature does not exceed the maximum junction temperature. According to Equation 1 and 2,

$\theta_{CH} + \theta_{HA}$ can be calculated as follows:

$$\text{Equation 3: } \theta_{CH} + \theta_{HA} = (T_j - T_A) / P - \theta_{JC}$$

Assume:

$$T_j = 125^\circ\text{C (} T_{jmax} \text{)}$$

$$T_A = 85^\circ\text{C}$$

$$P = 1.9\text{ W}$$

$$\theta_{JC} = 16.1^\circ\text{C/W (TQFP/EQG100)}$$

$\theta_{CH} + \theta_{HA}$ can be calculated as follows:

$$\theta_{CH} + \theta_{HA} = (125^\circ\text{C} - 85^\circ\text{C}) / 1.9\text{W} - 16.1^\circ\text{C/W} = 5.0^\circ\text{C/W}$$

That is, if a heatsink and heatsink attachment whose $\theta_{CH} + \theta_{HA}$ is below or equal to 5.0°C/W is used in such operation environment, the junction temperature will not exceed the maximum junction temperature.

8.4 TQFP EPAD THERMAL RELEASE PATH

In order to maximize both the removal of heat from the package and the electrical performance, a land pattern must be incorporated on the Printed Circuit Board (PCB) within the footprint of the package corresponding to the exposed metal pad or exposed heat slug on the package, as shown in Figure 29. The solderable area on the PCB, as defined

by the solder mask, should be at least the same size/shape as the exposed pad/slug area on the package to maximize the thermal/electrical performance. Sufficient clearance should be designed on the PCB between the outer edges of the land pattern and the inner edges of pad pattern for the leads to avoid any shorts.

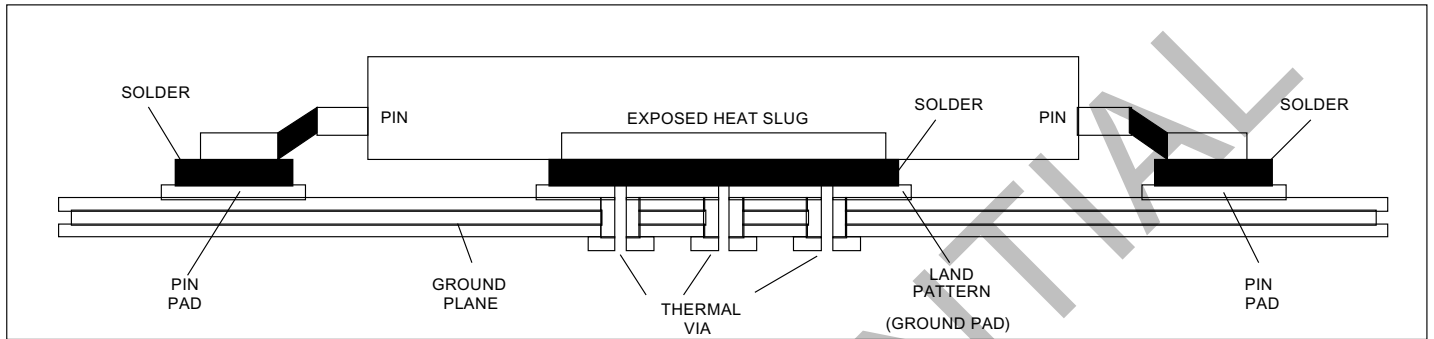

Figure 29. Assembly for Expose Pad thermal Release Path (Side View)

While the land pattern on the PCB provides a means of heat transfer and electrical grounding from the package to the board through a solder joint, thermal vias are necessary to effectively conduct from the surface of the PCB to the ground plane(s). The land pattern must be connected to ground through these vias. The vias act as 'heat pipes'. The number of vias (i.e. 'heat pipes') are application specific and dependent upon the package power dissipation as well as electrical conductivity requirements. Thus, thermal and electrical analysis and/or testing are recommended to determine the minimum number needed. Maximum thermal and electrical performance is achieved when an array of vias is incorporated in the land pattern. It is recommended to use as many vias con-

nected to ground as possible. It is also recommended that the via diameter should be 12 to 13mils (0.30 to 0.33mm) with 1 oz copper via barrel plating. This is desirable to avoid any solder wicking inside the via during the soldering process which may result in voids in solder between the exposed pad/slug and the thermal land. Precautions should be taken to eliminate any solder voids between the exposed heat slug and the land pattern. Note: These recommendations are to be used as a guideline only. For further information, please refer to the Application Note on the Surface Mount Assembly of Amkor's Thermally/Electrically Enhance Leadframe Base Package, Amkor Technology.

9 ELECTRICAL SPECIFICATIONS

9.1 ABSOLUTE MAXIMUM RATING

Table 45: Absolute Maximum Rating

Symbol	Parameter	Min	Max	Unit
V_{DD}	Supply Voltage V_{DD}	-0.5	5.5	V
V_{IN}	Input Voltage (non-supply pins)		5.5	V
V_{OUT}	Output Voltage (non-supply pins)		5.5	V
T_A	Ambient Operating Temperature Range	-40	85	°C
T_{STOR}	Storage Temperature	-50	150	°C
ESD Performance CDM Classification - Class II (JESD22-C101E) HBM Classification - Class 2 (JESD22-A114)				

9.2 RECOMMENDED OPERATION CONDITIONS

Table 46: Recommended Operation Conditions

Symbol	Parameter	Min	Typ	Max	Unit	Test Condition
V_{DD}	Power Supply (DC voltage) V_{DD}	3.135	3.3	3.465	V	
T_A	Ambient Temperature Range	-40		85	°C	
I_{DD}	Supply Current			305	mA	Exclude the loading current and power
P_{TOT}	Total Power Dissipation			1.1	W	

9.3 I/O SPECIFICATIONS

9.3.1 CMOS INPUT / OUTPUT PORT

Table 47: CMOS Input Port Electrical Characteristics

Parameter	Description	Min	Typ	Max	Unit	Test Condition
V _{IH}	Input Voltage High	2			V	
V _{IL}	Input Voltage Low			0.8	V	
I _{IN}	Input Current			10	μA	
V _{IN}	Input Voltage	-0.5		5.5	V	

Table 48: CMOS Input Port with Internal Pull-Up Resistor Electrical Characteristics

Parameter	Description	Min	Typ	Max	Unit	Test Condition
V _{IH}	Input Voltage High	2			V	
V _{IL}	Input Voltage Low			0.8	V	
P _U	Pull-Up Resistor		44		KΩ	
I _{IN}	Input Current			±150	μA	
V _{IN}	Input Voltage	-0.5		5.5	V	

Table 49: CMOS Input Port with Internal Pull-Down Resistor Electrical Characteristics

Parameter	Description	Min	Typ	Max	Unit	Test Condition
V _{IH}	Input Voltage High	2			V	
V _{IL}	Input Voltage Low			0.8	V	
P _D	Pull-Down Resistor		60		KΩ	other CMOS input port with internal pull-down resistor
			60			TRST and TCK pin
			60			A[6:0], AD[7:0] pins
I _{IN}	Input Current			±150	μA	other CMOS input port with internal pull-down resistor
				±150		TRST and TCK pin
				±150		A[6:0], AD[7:0] pins
V _{IN}	Input Voltage	-0.5		5.5	V	

Table 50: CMOS Output Port Electrical Characteristics

Application Pin	Parameter	Description	Min	Typ	Max	Unit	Test Condition
Output Clock	V _{OH}	Output Voltage High	2.4		V _{DD}	V	I _{OH} = -8 mA
	V _{OL}	Output Voltage Low			0.4	V	I _{OL} = 8 mA
	t _R	Rise time			4	ns	15 pF
	t _F	Fall time			4	ns	15 pF
Other Output	V _{OH}	Output Voltage High	2.4		V _{DD}	V	I _{OH} = -4 mA
	V _{OL}	Output Voltage Low			0.4	V	I _{OL} = 4 mA
	t _R	Rise Time			15	ns	50 pF
	t _F	Fall Time			15	ns	50 pF

9.3.2 PECL / LVDS INPUT / OUTPUT PORT

9.3.2.1 PECL Input / Output Port

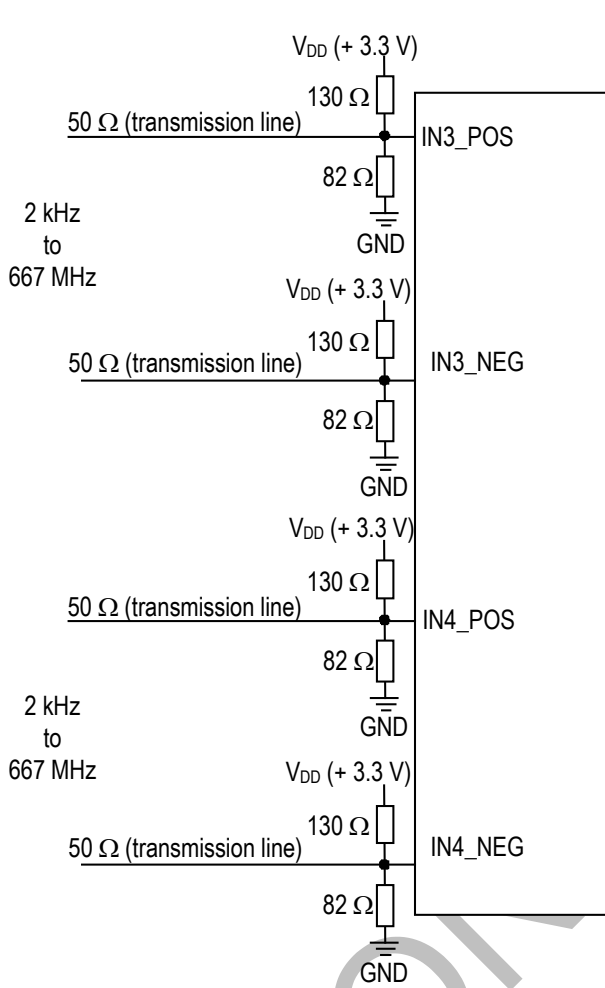

Figure 30. Recommended PECL Input Port Line Termination

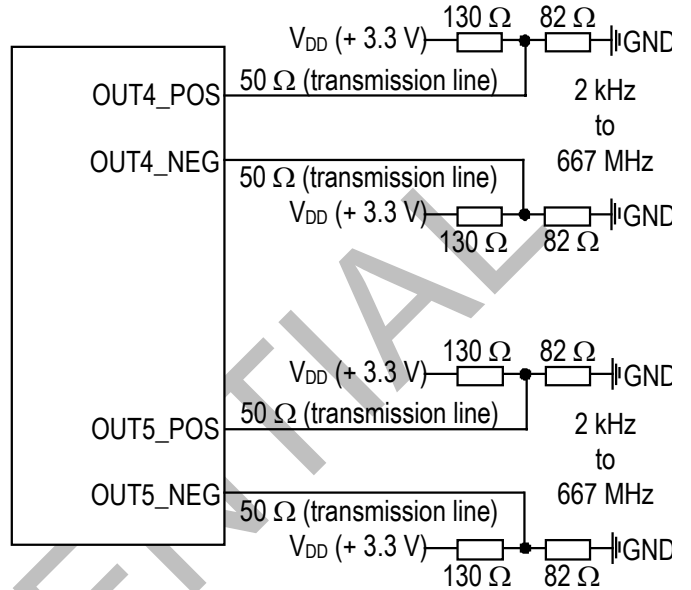

Figure 31. Recommended PECL Output Port Line Termination

Table 51: PECL Input / Output Port Electrical Characteristics

Parameter	Description	Min	Typ	Max	Unit	Test Condition
V_{IL}	Input Low Voltage, Differential Inputs ¹	$V_{DD} - 2.5$		$V_{DD} - 0.5$	V	
V_{IH}	Input High Voltage, Differential Inputs ¹	$V_{DD} - 2.4$		$V_{DD} - 0.4$	V	
V_{ID}	Input Differential Voltage	1		1.4	V	
V_{IL_S}	Input Low Voltage, Single-ended Input ²	$V_{DD} - 2.4$		$V_{DD} - 1.5$	V	
V_{IH_S}	Input High Voltage, Single-ended Input ²	$V_{DD} - 1.3$		$V_{DD} - 0.5$	V	
I_{IH}	Input High Current, Input Differential Voltage $V_{ID} = 1.4$ V			10	μ A	
I_{IL}	Input Low Current, Input Differential Voltage $V_{ID} = 1.4$ V	-10			μ A	
V_{OL}	Output Voltage Low ³	1.15		1.75	V	
V_{OH}	Output Voltage High ³	1.95		2.55	V	
V_{OD}	Output Differential Voltage ³	0.65		0.85	V	
t_{RISE}	Output Rise time (20% to 80%)	150		300	pS	
t_{FALL}	Output Fall time (20% to 80%)	150		300	pS	
t_{SKEW}	Output Differential Skew			100	pS	

Note:

1. Assuming a differential input voltage of at least 100 mV.
2. Unused differential input terminated to $V_{DD} - 1.4$ V.
3. With 50 Ω load on each pin to $V_{DD} - 2$ V, i.e. 82 Ω to GND and 130 Ω to V_{DD} .

9.3.2.2 LVDS Input / Output Port

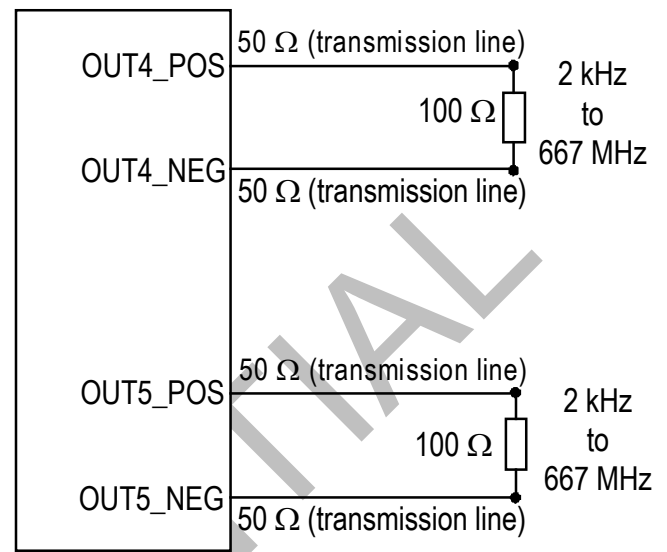
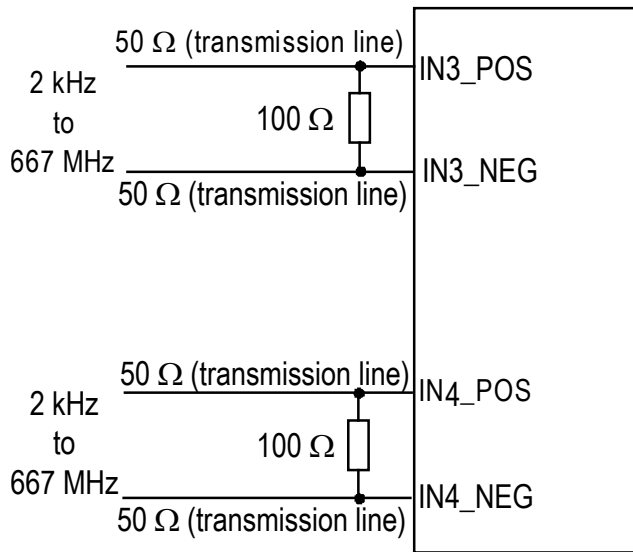

Figure 32. Recommended LVDS Input Port Line Termination

Figure 33. Recommended LVDS Output Port Line Termination

Table 52: LVDS Input / Output Port Electrical Characteristics

Parameter	Description	Min	Typ	Max	Unit	Test Condition
V_{CM}	Input Common-mode Voltage Range	200	1200	2200	mV	
V_{DIFF}	Input Peak Differential Voltage	100		900	mV	
V_{IDTH}	Input Differential Threshold	-100		100	mV	
R_{TERM}	External Differential Termination Impedance	95	100	105	Ω	
V_{OH}	Output Voltage High	1150		1850	mV	$R_{LOAD} = 100 \Omega \pm 1\%$
V_{OL}	Output Voltage Low	850		1350	mV	$R_{LOAD} = 100 \Omega \pm 1\%$
V_{OD}	Differential Output Voltage	247	350	454	mV	$R_{LOAD} = 100 \Omega \pm 1\%$
V_{OS}	Output Offset Voltage	1095		1405	mV	$R_{LOAD} = 100 \Omega \pm 1\%$
R_O	Differential Output Impedance	80		120	Ω	$V_{CM} = 1.0 V$ or $1.4 V$
ΔR_O	R_O Mismatch between A and B			20	%	$V_{CM} = 1.0 V$ or $1.4 V$
ΔV_{OD}	Change in V_{OD} between Logic 0 and Logic 1			50	mV	$R_{LOAD} = 100 \Omega \pm 1\%$
ΔV_{OS}	Change in V_{OS} between Logic 0 and Logic 1			50	mV	$R_{LOAD} = 100 \Omega \pm 1\%$
I_{SA}, I_{SB}	Output Current			24	mA	Driver shorted to GND
I_{SAB}	Output Current			12	mA	Driver shorted together
t_{RISE}	Output Rise time (20% to 80%)	100		300	pS	$R_{LOAD} = 100 \Omega \pm 1\%$
t_{FALL}	Output Fall time (20% to 80%)	100		300	pS	$R_{LOAD} = 100 \Omega \pm 1\%$
t_{SKEW}	Output Differential Skew			100	pS	$R_{LOAD} = 100 \Omega \pm 1\%$

9.3.2.3 Single-Ended Input for Differential Input

This is a recommended and tested interface circuit to drive differential input with a single-ended signal.

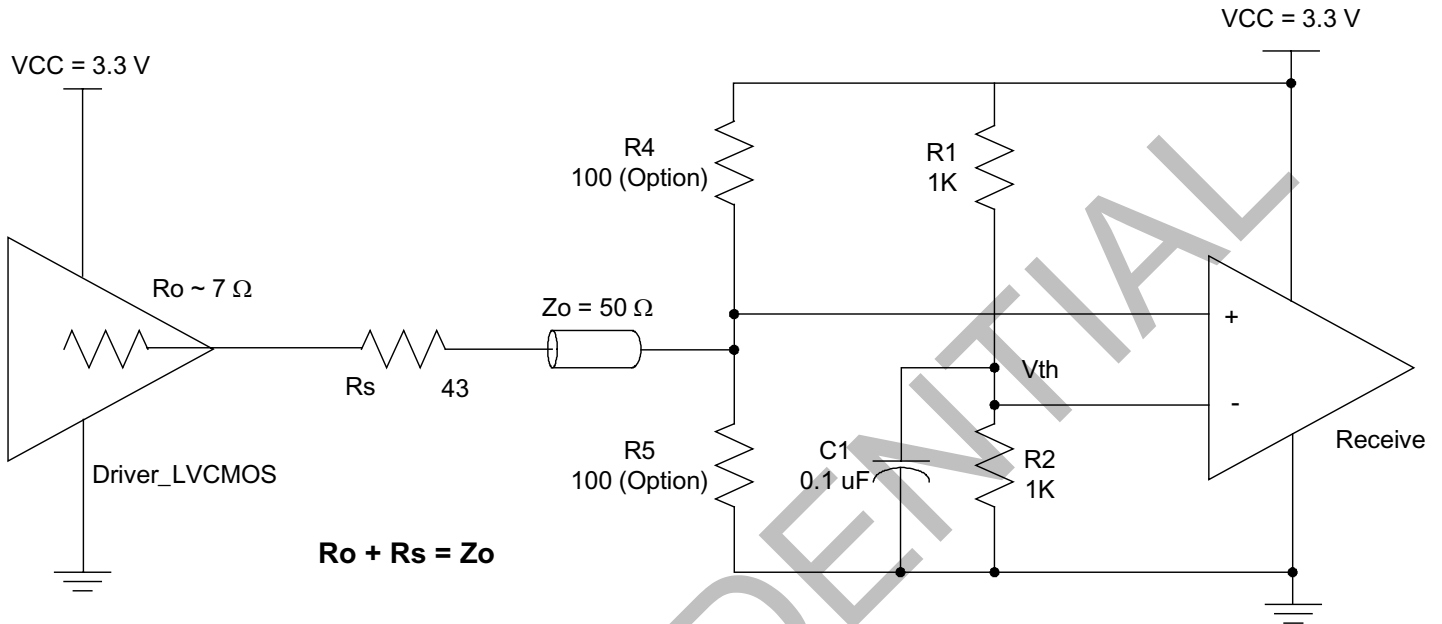

Figure 34. Example of Single-Ended Signal to Drive Differential Input

$$V_{th} = V_{DD} * [R_2 / (R_1 + R_2)]$$

For the example in Figure 34, $R_1 = R_2$, so $V_{th} = V_{DD} / 2 = 1.65 V$

The suggested single-ended signal input:

$$V_{IHmax} = V_{DD}$$

$$V_{ILmin} = 0 V$$

$$V_{swing} = 0.6 V \sim V_{DD}$$

$$DC \text{ offset (Swing Center)} = V_{th} / 2 \pm V_{swing} * 10\%$$

9.4 JITTER PERFORMANCE

Table 53: Output Clock Jitter Generation (jitter measured on one differential output (OUT6 or OUT7) with all other outputs disabled)

Test Definition ¹	Output Frequency	RMS Typ	Note	Test Filter
25 MHz without T0 APLL	25 MHz	46 pS		12 kHz - 12.5 MHz
125 MHz with T0 APLL	125 MHz	22 pS		12 kHz - 20 MHz
156.25 MHz with T0 APLL	156.25 MHz	23 pS		12 kHz - 20 MHz
N x 2.048 MHz without APLL		46 pS		20 Hz - 100 kHz
N x 2.048 MHz with T0 APLL		45 pS		20 Hz - 100 kHz
N x 1.544 MHz without APLL		47 pS		10 Hz - 40 kHz
N x 1.544 MHz with T0 APLL		47 pS		10 Hz - 40 kHz
44.736 MHz without APLL	44.736 MHz	50 pS		100 Hz - 800 kHz
44.736 MHz with T0 APLL	44.736 MHz	43 pS		100 Hz - 800 kHz
34.368 MHz without APLL	34.368 MHz	43 pS		10 Hz - 400 kHz
34.368 MHz with T0 APLL	34.368 MHz	48 pS		10 Hz - 400 kHz
625 MHz with T0 APLL	625 MHz	25 pS		1.875 MHz - 20 MHz

Table 53: Output Clock Jitter Generation (jitter measured on one differential output (OUT6 or OUT7) with all other outputs disabled)

Test Definition ¹	Output Frequency	RMS Typ	Note	Test Filter
OC-3 and STM-1 (Chip T0 DPLL + T0 APLL) 19.44 MHz, 77.76 MHz, 155.52 MHz output	19.44 MHz	1.7 pS	GR-253-CORE and ITU-T G.813 Option 2 limit 0.1 UI p-p (1 UI-6430 pS)	12 kHz - 1.3 MHz
		1.9 pS	ITU-T G.813 Option 1 limit 0.5 UI p-p (1 UI-6430 pS)	500 Hz to 1.3 MHz
		1.6 pS	ITU-T G.813 Option 1 limit 0.1 UI p-p (1 UI-6430 pS)	65 kHz to 1.3 MHz
	77.76 MHz	1.7 pS	GR-253-CORE and ITU-T G.813 Option 2 limit 0.1 UI p-p (1 UI-6430 pS)	12 kHz - 1.3 MHz
		1.8 pS	ITU-T G.813 Option 1 limit 0.5 UI p-p (1 UI-6430 pS)	500 Hz to 1.3 MHz
		1.6 pS	ITU-T G.813 Option 1 limit 0.1 UI p-p (1 UI-6430 pS)	65 kHz to 1.3 MHz
	155.52 MHz	1.6 pS	GR-253-CORE and ITU-T G.813 Option 2 limit 0.1 UI p-p (1 UI-6430 pS)	12 kHz - 1.3 MHz
		1.8 pS	ITU-T G.813 Option 1 limit 0.5 UI p-p (1 UI-6430 pS)	500 Hz to 1.3 MHz
		1.5 pS	ITU-T G.813 Option 1 limit 0.1 UI p-p (1 UI-6430 pS)	65 kHz to 1.3 MHz

Table 53: Output Clock Jitter Generation (jitter measured on one differential output (OUT6 or OUT7) with all other outputs disabled)

Test Definition ¹	Output Frequency	RMS Typ	Note	Test Filter
OC-12 and STM-4 (Chip T0 DPPLL + T0 APPLL) 77.76 MHz, 155.52 MHz, 622.08 MHz output	77.76 MHz	1.7 pS	GR-253-CORE and ITU-T G.813 Option 2 limit 0.1 UI p-p (1 UI-1608 pS)	12 kHz - 5 MHz
		1.8 pS	ITU-T G.813 Option 1 limit 0.5 UI p-p (1 UI-1608 pS)	1000 Hz to 5 MHz
		1.4 pS	ITU-T G.813 Option 1 limit 0.1 UI p-p (1 UI-1608 pS)	250 kHz to 5 MHz
	155.52 MHz	1.7 pS	GR-253-CORE and ITU-T G.813 Option 2 limit 0.1 UI p-p (1 UI-1608 pS)	12 kHz - 5 MHz
		1.8 pS	ITU-T G.813 Option 1 limit 0.5 UI p-p (1 UI-1608 pS)	1000 Hz to 5 MHz
		1.4 pS	ITU-T G.813 Option 1 limit 0.1 UI p-p (1 UI-1608 pS)	250 kHz to 5 MHz
	622.08 MHz	1.7 pS	GR-253-CORE and ITU-T G.813 Option 2 limit 0.1 UI p-p (1 UI-1608 pS)	12 kHz - 5 MHz
		1.8 pS	ITU-T G.813 Option 1 limit 0.5 UI p-p (1 UI-1608 pS)	1000 Hz to 5 MHz
		1.4 pS	ITU-T G.813 Option 1 limit 0.1 UI p-p (1 UI-1608 pS)	250 kHz to 5 MHz
OC-48 and STM-16 (Chip T0 DPPLL + T0 APPLL) 155.52 MHz, 622.08 MHz output	155.52 MHz	1.7 pS	GR-253-CORE and ITU-T G.813 Option 2 limit 0.1 UI p-p (1 UI-401.878 pS)	12 kHz - 20 MHz
		1.7 pS	ITU-T G.813 Option 1 limit 0.5 UI p-p (1 UI-401.878 pS)	5000 Hz to 20 MHz
		0.9 pS	ITU-T G.813 Option 1 limit 0.1 UI p-p (1 UI-401.878 pS)	1 MHz to 20 MHz
	622.08 MHz	1.7 pS	GR-253-CORE and ITU-T G.813 Option 2 limit 0.1 UI p-p (1 UI-401.878 pS)	12 kHz - 20 MHz
		1.7 pS	ITU-T G.813 Option 1 limit 0.5 UI p-p (1 UI-401.878 pS)	5000 Hz to 20 MHz
		0.8 pS	ITU-T G.813 Option 1 limit 0.1 UI p-p (1 UI-401.878 pS)	1 MHz to 20 MHz

Note:
1. Rakon TCXO E3198 is used.

Table 54: Output Clock Jitter Generation (jitter measured on one CMOS output (OUT1 - OUT5) with all other outputs disabled)

Test Definition ¹	Output Frequency	RMS Typ	Note	Test Filter
25 MHz without T0 APLL	25 MHz	47 pS		12 kHz - 12.5 MHz
125 MHz with T4 APLL	125 MHz	24 pS		12 kHz - 20 MHz
156.25 MHz with T4 APLL	156.25 MHz	23 pS		12 kHz - 20 MHz
N x 2.048 MHz without APLL		41 pS		20 Hz - 100 kHz
N x 2.048 MHz with T0/T4 APLL		44 pS		20 Hz - 100 kHz
N x 1.544 MHz without APLL		43 pS		10 Hz - 40 kHz
N x 1.544 MHz with T0/T4 APLL		44 pS		10 Hz - 40 kHz
44.736 MHz without APLL	44.736 MHz	47 pS		100 Hz - 800 kHz
44.736 MHz with T0/T4 APLL	44.736 MHz	45 pS		100 Hz - 800 kHz
34.368 MHz without APLL	34.368 MHz	44 pS		10 Hz - 400 kHz
34.368 MHz with T0/T4 APLL	34.368 MHz	44 pS		10 Hz - 400 kHz
OC-3 and STM-1 (Chip T0 DPLL + T0 APLL) 19.44 MHz, 77.76 MHz, 155.52 MHz output	19.44 MHz	1.7 pS	GR-253-CORE and ITU-T G.813 Option 2 limit 0.1 UI p-p (1 UI-6430 pS)	12 kHz - 1.3 MHz
		1.9 pS	ITU-T G.813 Option 1 limit 0.5 UI p-p (1 UI-6430 pS)	500 Hz to 1.3 MHz
		1.7 pS	ITU-T G.813 Option 1 limit 0.1 UI p-p (1 UI-6430 pS)	65 kHz to 1.3 MHz
	77.76 MHz	1.8 pS	GR-253-CORE and ITU-T G.813 Option 2 limit 0.1 UI p-p (1 UI-6430 pS)	12 kHz - 1.3 MHz
		1.9 pS	ITU-T G.813 Option 1 limit 0.5 UI p-p (1 UI-6430 pS)	500 Hz to 1.3 MHz
		1.7 pS	ITU-T G.813 Option 1 limit 0.1 UI p-p (1 UI-6430 pS)	65 kHz to 1.3 MHz
	155.52 MHz	1.8 pS	GR-253-CORE and ITU-T G.813 Option 2 limit 0.1 UI p-p (1 UI-6430 pS)	12 kHz - 1.3 MHz
		1.9 pS	ITU-T G.813 Option 1 limit 0.5 UI p-p (1 UI-6430 pS)	500 Hz to 1.3 MHz
		1.7 pS	ITU-T G.813 Option 1 limit 0.1 UI p-p (1 UI-6430 pS)	65 kHz to 1.3 MHz

Note:
1. Rakon TCXO E3198 is used.

9.5 OUTPUT WANDER GENERATION

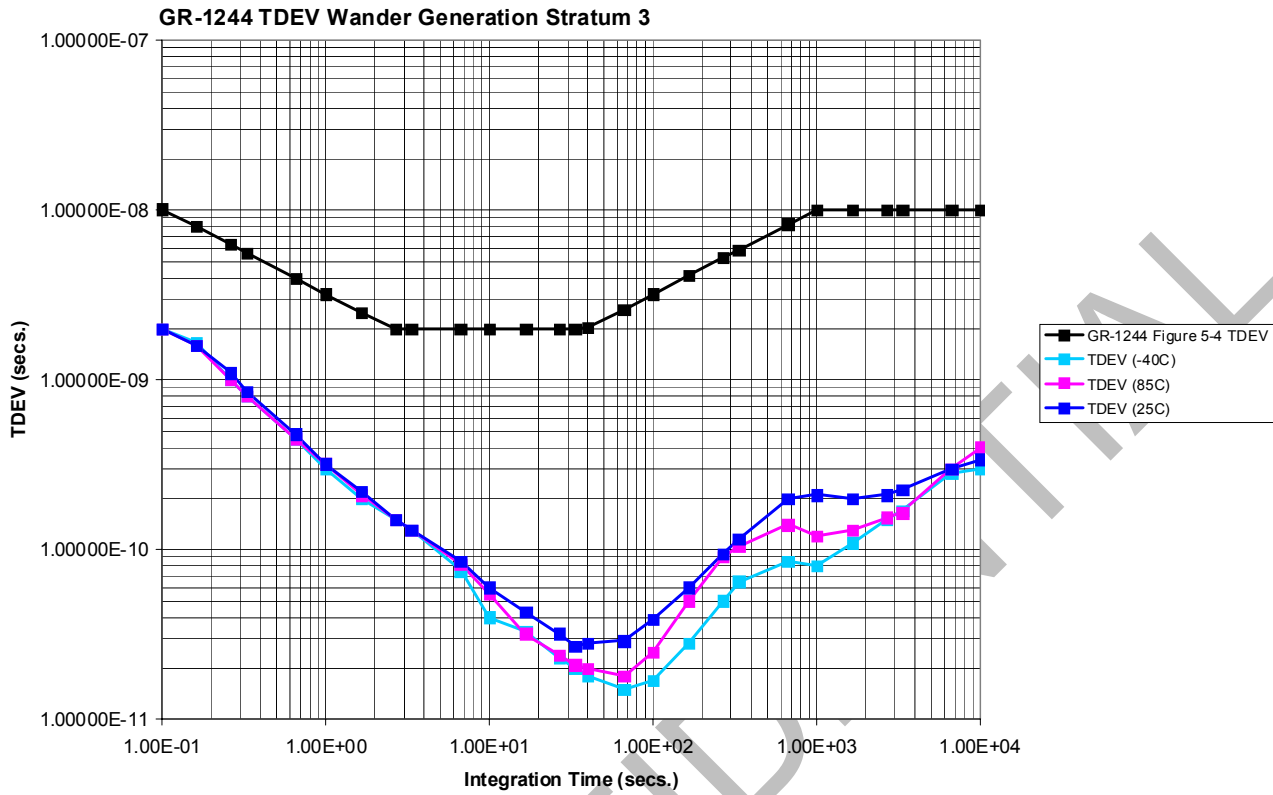

Figure 35. Output Wander Generation (TDEV)

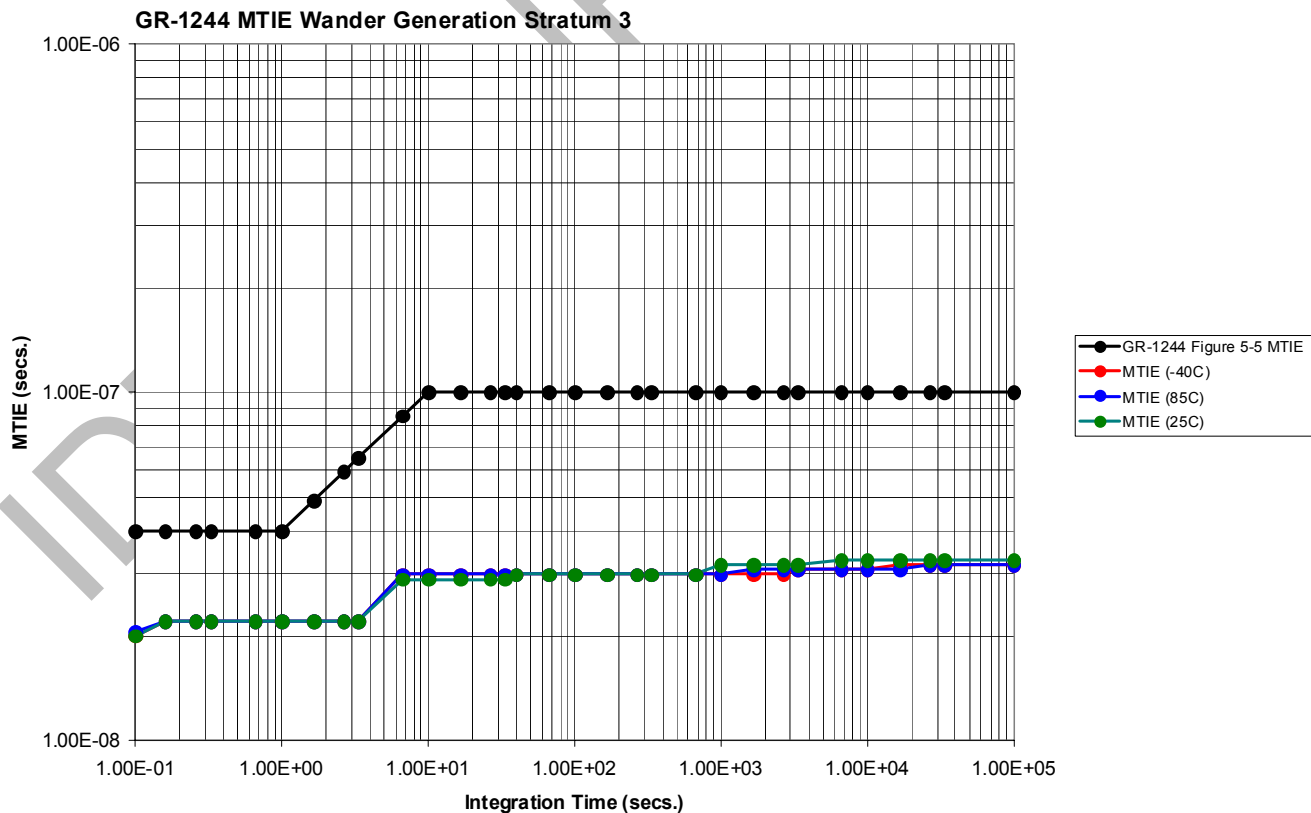

Figure 36. Output Wander Generation (MTIE)

9.6 INPUT / OUTPUT CLOCK TIMING

The inputs and outputs are aligned ideally. But due to the circuit delays, there is delay between the inputs and outputs.

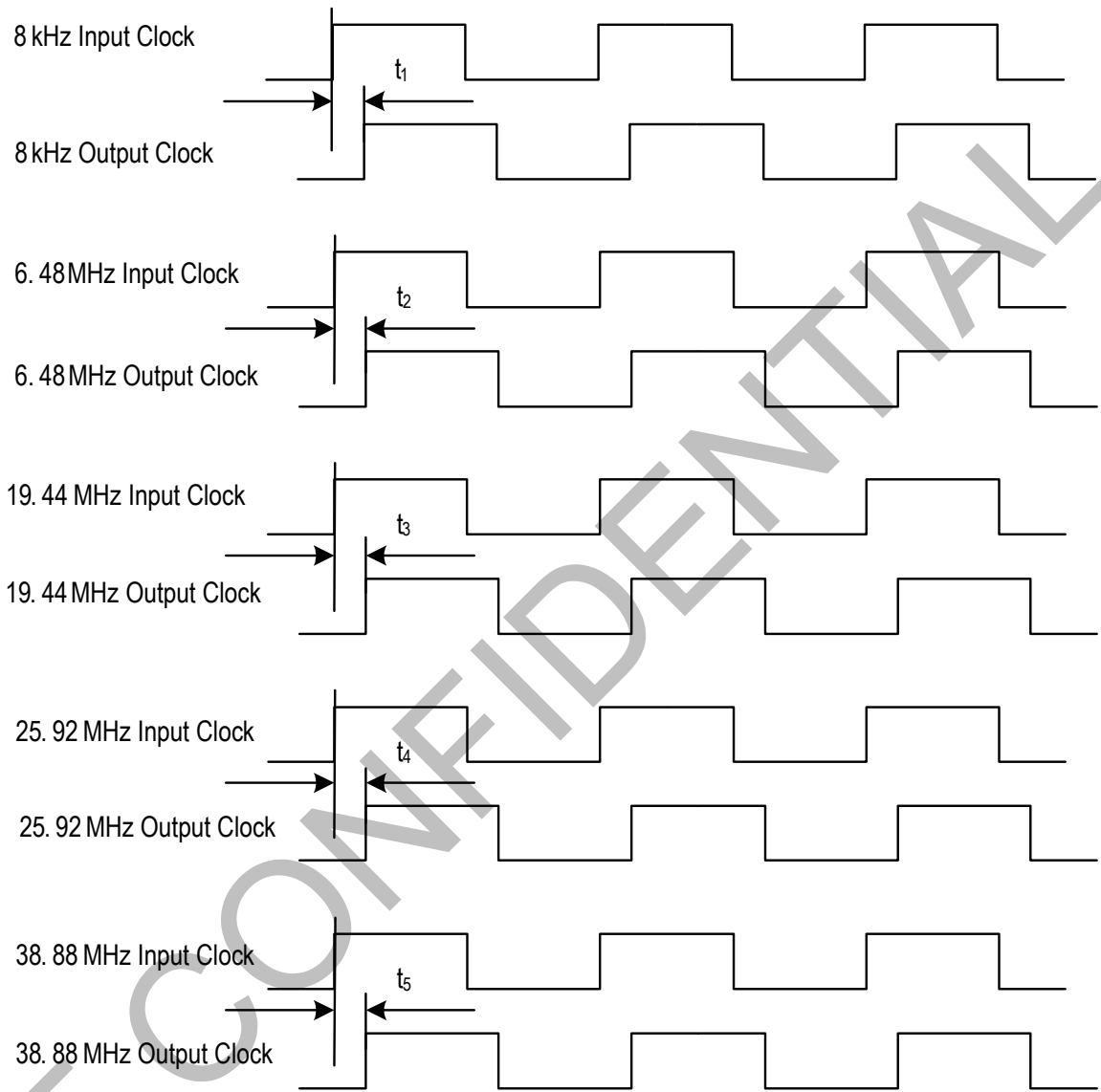

Figure 37. Input / Output Clock Timing

Table 55: Input/Output Clock Timing ³

Symbol	Typical Delay ¹ (ns)	Peak to Peak Delay Variation ² (ns)
t ₁	8	1
t ₂	5	1
t ₃	5	1
t ₄	6.5	1.5
t ₅	5	1

Note:

1. Typical delay provided as reference only.
2. 'Peak to Peak Delay Variation' is the delay variation that is guaranteed not to be exceeded for IN5 in Master/Slave operation.
3. Tested when IN3 is selected.

IDT CONFIDENTIAL

9.7 OUTPUT CLOCK TIMING

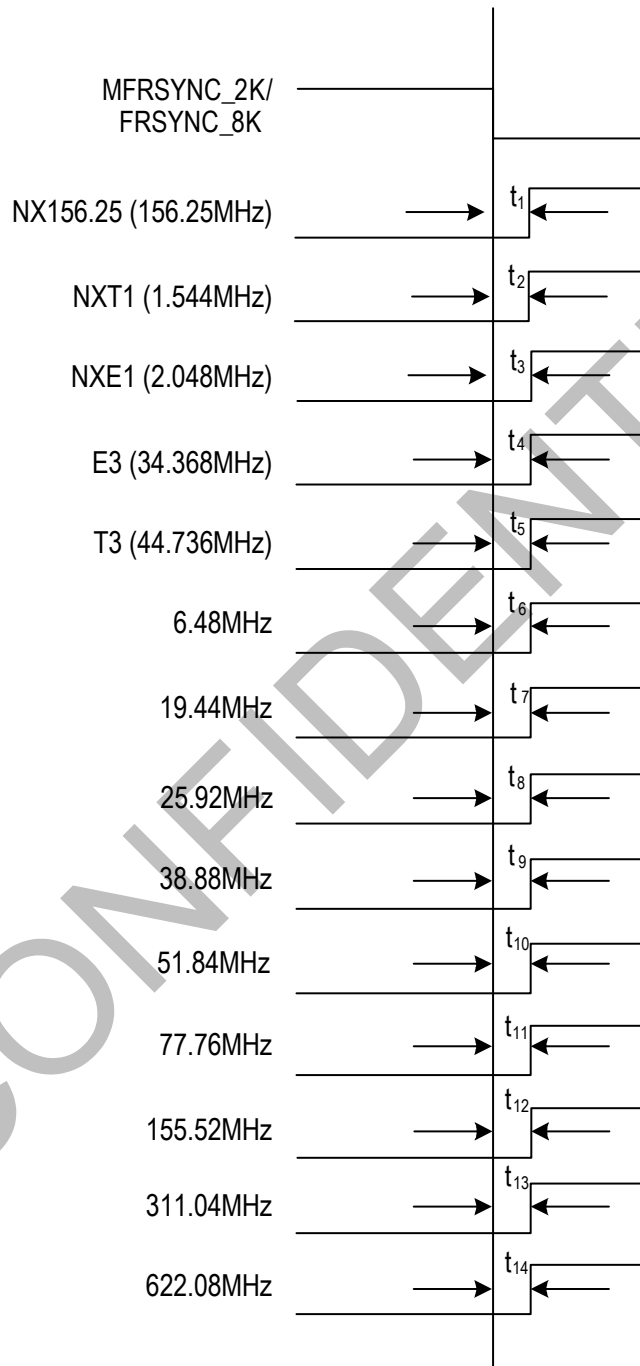

Figure 38. Output Clock Timing

Table 56: Output Clock Timing

Symbol	Typical Delay (ns)	Peak to Peak Delay Variation (ns)
t ₁	2.0	1
t ₂	-1.0	2
t ₃	-1.0	2
t ₄	-2.0	2
t ₅	-2.0	2
t ₆	-2.5	2
t ₇	-2.5	2
t ₈	-2.0	2
t ₉	-2.0	2
t ₁₀	-1.5	2
t ₁₁	-1.5	2
t ₁₂	-1.5	2
t ₁₃	-0.5	1
t ₁₄	-1.0	1

IDT CONFIDENTIAL



3G	---	Third Generation
ADSL	---	Asymmetric Digital Subscriber Line
APLL	---	Analog Phase Locked Loop
ATM	---	Asynchronous Transfer Mode
BITS	---	Building Integrated Timing Supply
CMOS	---	Complementary Metal-Oxide Semiconductor
DCO	---	Digital Controlled Oscillator
DPLL	---	Digital Phase Locked Loop
DSL	---	Digital Subscriber Line
DSLAM	---	Digital Subscriber Line Access MUX
DWDM	---	Dense Wavelength Division Multiplexing
EPROM	---	Erasable Programmable Read Only Memory
ETH	---	Synchronous Ethernet System
GPS	---	Global Positioning System
GSM	---	Global System for Mobile Communications
IIR	---	Infinite Impulse Response
IP	---	Internet Protocol
ISDN	---	Integrated Services Digital Network
JTAG	---	Joint Test Action Group
LPF	---	Low Pass Filter
LVDS	---	Low Voltage Differential Signal
MTIE	---	Maximum Time Interval Error
MUX	---	Multiplexer
OBSAI	---	Open Base Station Architecture Initiative
OC-n	---	Optical Carried rate, n = 1, 3, 12, 48, 192, 768; 51 Mbit/s, 155 Mbit/s, 622 Mbit/s, 2.5 Gbit/s, 10 Gbit/s, 40 Gbit/s.
PBO	---	Phase Build-Out

PDH	---	Plesiochronous Digital Hierarchy
PECL	---	Positive Emitter Coupled Logic
PFD	---	Phase & Frequency Detector
PLL	---	Phase Locked Loop
RMS	---	Root Mean Square
PRS	---	Primary Reference Source
SDH	---	Synchronous Digital Hierarchy
SEC	---	SDH / SONET Equipment Clock
SMC	---	SONET Minimum Clock
SONET	---	Synchronous Optical Network
SSU	---	Synchronization Supply Unit
STM	---	Synchronous Transfer Mode
TCM-ISDN	---	Time Compression Multiplexing Integrated Services Digital Network
TDEV	---	Time Deviation
UI	---	Unit Interval
WLL	---	Wireless Local Loop

IDT CONFIDENTIAL



A		Frequency Hard Alarm	23, 28
Averaged Phase Error	33	Frequency Hard Alarm Threshold	23
B		H	
Bandwidths and Damping Factors	33	Hard Limit	26
Acquisition Bandwidth and Damping Factor	33	Holdover Frequency Offset	34
Locked Bandwidth and Damping Factor	33	I	
Starting Bandwidth and Damping Factor	33	IIR	34
C		Input Clock Frequency	23
Calibration	18	Input Clock Selection	24
Coarse Phase Loss	26	Automatic selection	25, 28
Crystal Oscillator	18	External Fast selection	24, 28
Current Frequency Offset	33	Forced selection	25, 28
D		Internal Leaky Bucket Accumulator	22
DCO	33	Bucket Size	22
Division Factor	20	Decay Rate	22
DPLL Hard Alarm	26	Lower Threshold	22
DPLL Hard Limit	26	Upper Threshold	22
DPLL Operating Mode	33, 34	L	
Free-Run mode	33, 34	Limit	36
Holdover mode	34, 35	LPF	33
Automatic Fast Averaged	34	M	
Automatic Instantaneous	34	Master / Slave Application	46
Automatic Slow Averaged	34	Master / Slave Configuration	43
Manual	34	Master Clock	18
Locked mode	33, 34	Microprocessor Interface	47
Temp-Holdover mode	33	microprocessor interface	
Lost-Phase mode	33	EPROM	49
Pre-Locked mode	33	Intel	52
Pre-Locked2 mode	34	Motorola	54
DPLL Soft Alarm	26	Multiplexed	50
DPLL Soft Limit	26	Serial	56
E		N	
External Sync Alarm	40	No-activity Alarm	22, 28
F		P	
Fast Loss	26	PBO	36
Fine Phase Loss	26		

PFD 33

Phase Lock Alarm 27, 28

Phase Offset 36

Phase-compared 26, 36

Phase-time 36

Pre-Divider 20

 DivN Divider 20

 HF Divider 20

 Lock 8k Divider 20

R

Reference Clock 23

S

Selected Input Clock Switch 28

 Non-Revertive switch 29

 Revertive switch 28

State Machine 30, 32

V

Validity 28

IDT CONFIDENTIAL

PACKAGE DIMENSIONS

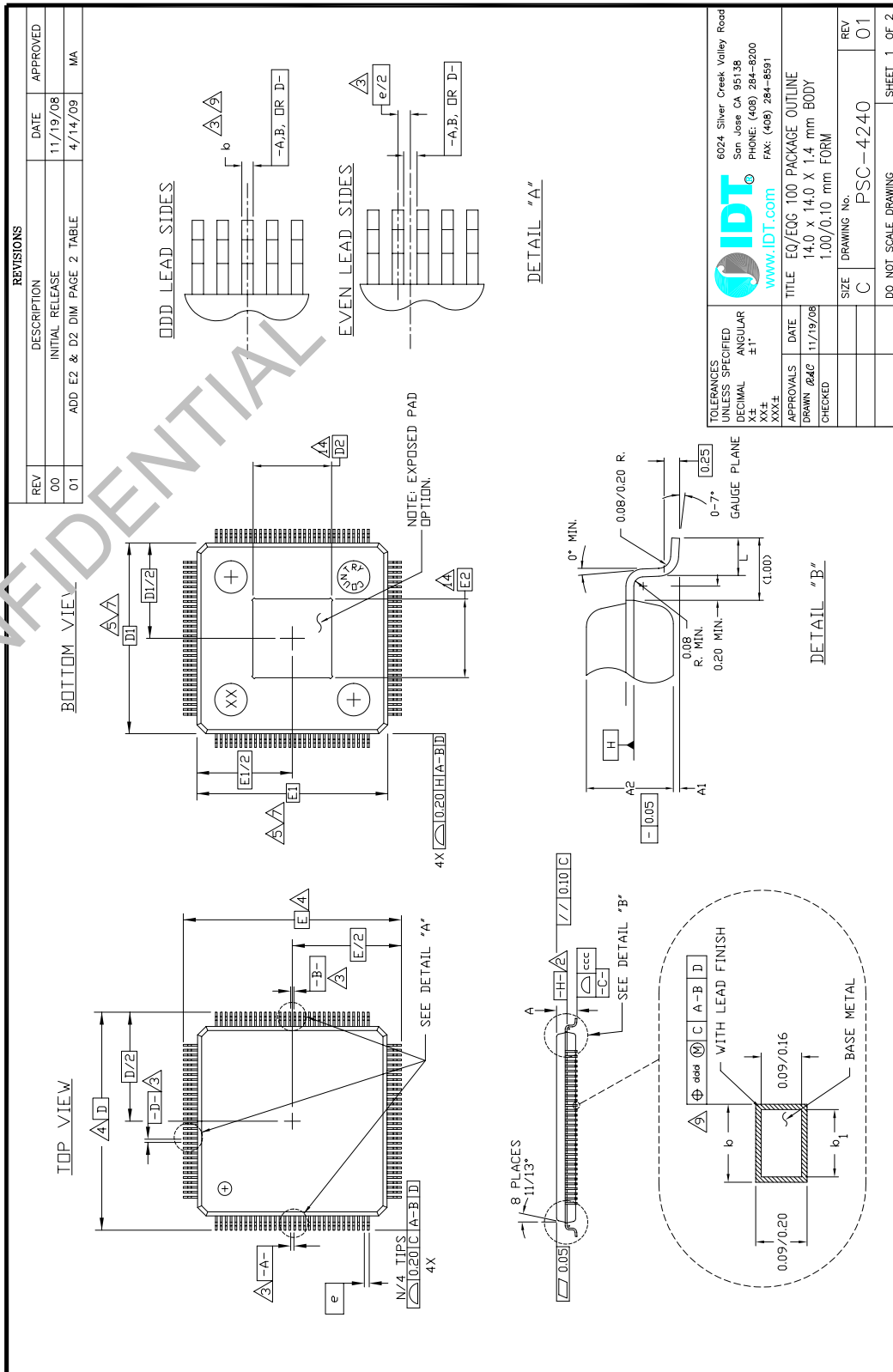

Figure 39. 100-Pin EQG Package Dimensions (a) (in Millimeters)

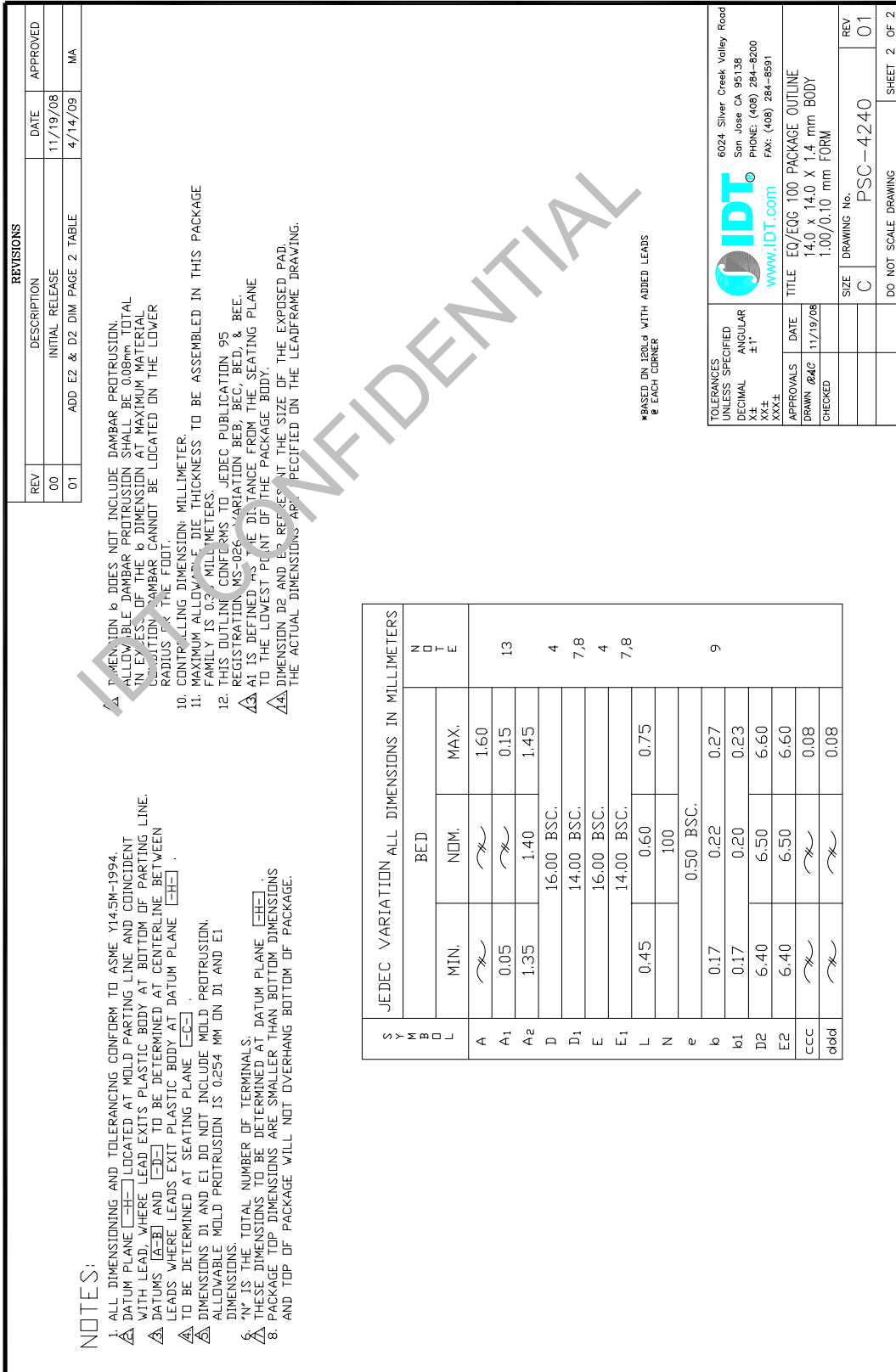

Figure 40. 100-Pin EQG Package Dimensions (b) (in Millimeters)

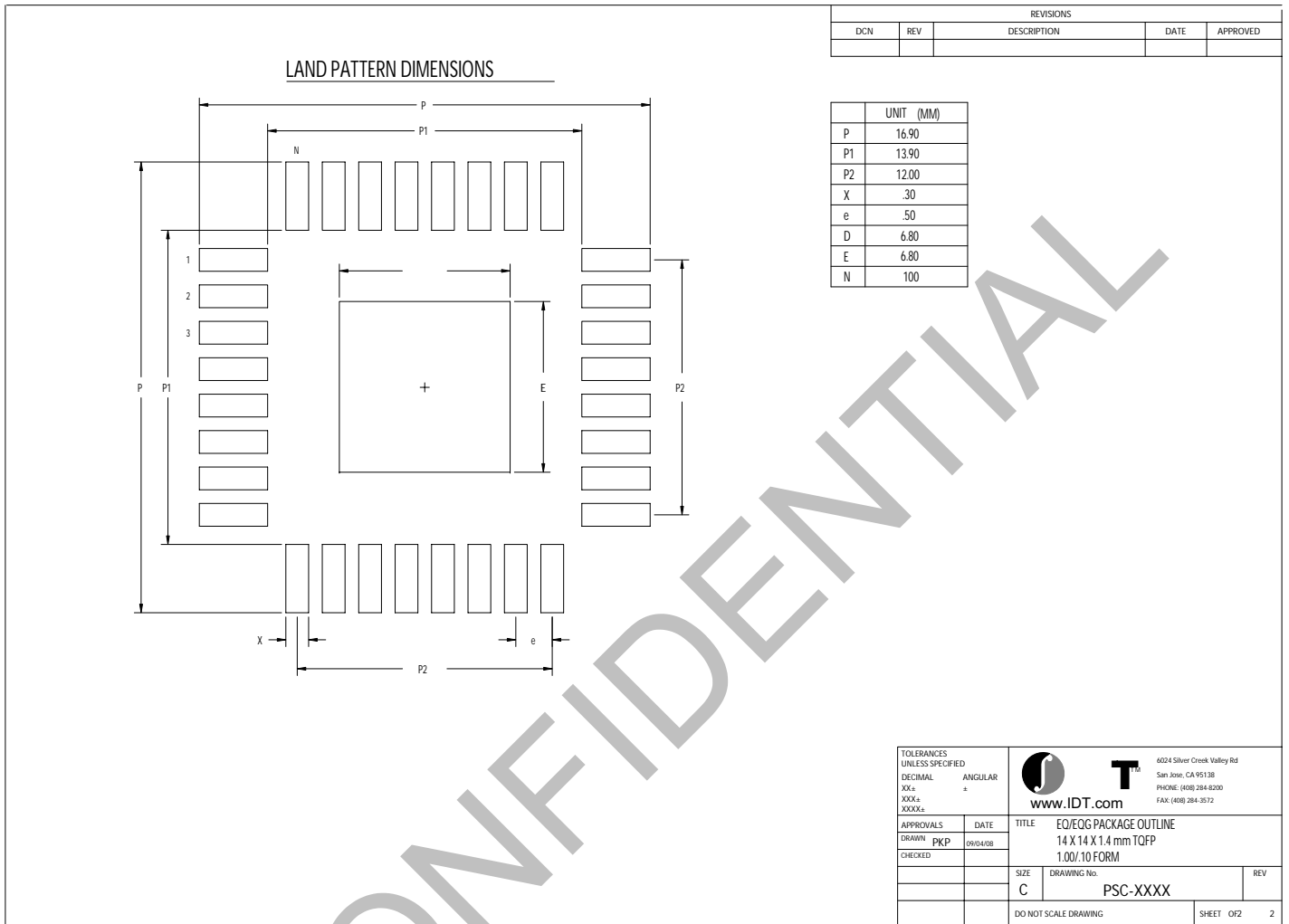
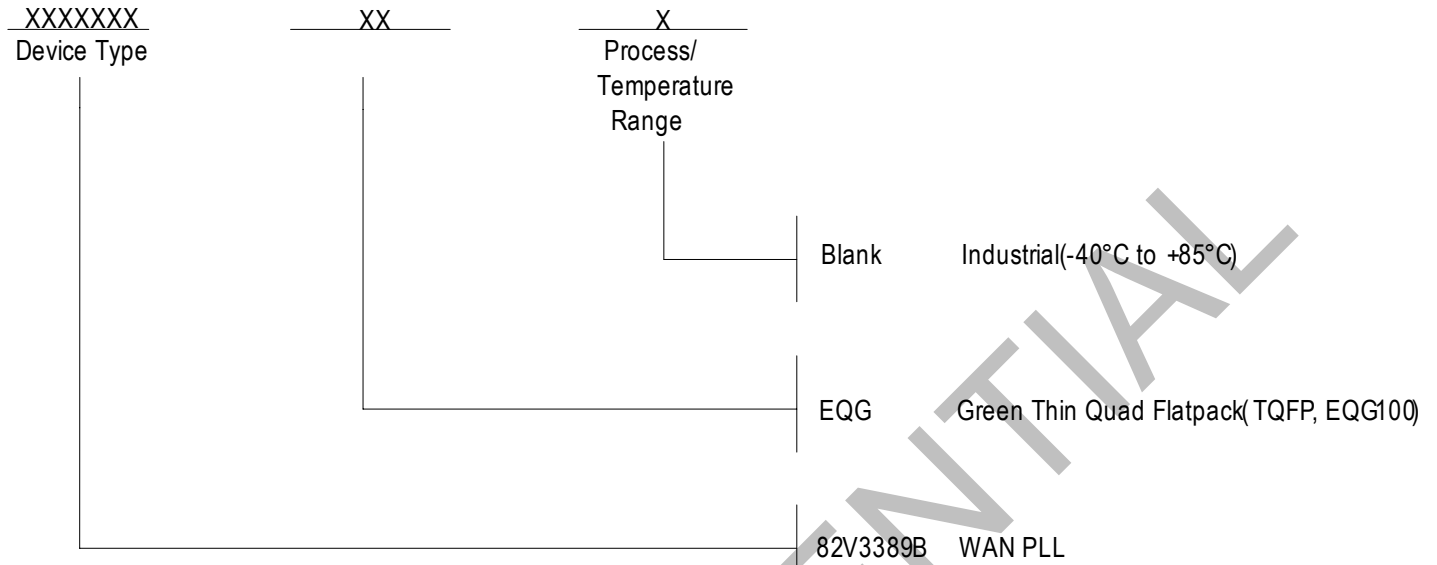

Figure 41. EQG100 Recommended Land Pattern with Exposed Pad (in Millimeters)

ORDERING INFORMATION



Revision History

- February 17, 2011 Initial Revision
- March 3, 2011 Page 155, Ordering Information Table - deleted PNG package information.
- May 31, 2011 Page 136, Table 51, PECL Input/Output Port Electrical Characteristics - corrected typo for VOH unit from mV to V.
- March 23, 2012 Page 120, T0_T4_APLL_BW_CNFG - T0 / T4 APLL Bandwidth Configurartion section / Address: 6AH Table - Rows 5-3 and 2-0 deleted 10KHz, 20 KHz and 50 KHz in the Description column; and added 000 - 010: Reserved.
- June 11, 2012 Page 65, ID[7:0] - Device ID 1 Default Value: 10010000
Page 66, ID[15:8] - Device ID 2 Default Value: 00110011
- June 13, 2012 Page 14, Pin 90 (OUT1): deleted 312.5 MHz.
Pin 93 (OUT2): changed description to read the same as OUT1.
Pin 94 (OUT3): changed description to read the same as OUT1.
Pins 34, 35 (OUT4_POS / _NEG) and Pins 36, 37 (OUT5_POS / _NEG) swapped descriptions.

IMPORTANT NOTICE AND DISCLAIMER

RENESAS ELECTRONICS CORPORATION AND ITS SUBSIDIARIES (“RENESAS”) PROVIDES TECHNICAL SPECIFICATIONS AND RELIABILITY DATA (INCLUDING DATASHEETS), DESIGN RESOURCES (INCLUDING REFERENCE DESIGNS), APPLICATION OR OTHER DESIGN ADVICE, WEB TOOLS, SAFETY INFORMATION, AND OTHER RESOURCES “AS IS” AND WITH ALL FAULTS, AND DISCLAIMS ALL WARRANTIES, EXPRESS OR IMPLIED, INCLUDING, WITHOUT LIMITATION, ANY IMPLIED WARRANTIES OF MERCHANTABILITY, FITNESS FOR A PARTICULAR PURPOSE, OR NON-INFRINGEMENT OF THIRD-PARTY INTELLECTUAL PROPERTY RIGHTS.

These resources are intended for developers who are designing with Renesas products. You are solely responsible for (1) selecting the appropriate products for your application, (2) designing, validating, and testing your application, and (3) ensuring your application meets applicable standards, and any other safety, security, or other requirements. These resources are subject to change without notice. Renesas grants you permission to use these resources only to develop an application that uses Renesas products. Other reproduction or use of these resources is strictly prohibited. No license is granted to any other Renesas intellectual property or to any third-party intellectual property. Renesas disclaims responsibility for, and you will fully indemnify Renesas and its representatives against, any claims, damages, costs, losses, or liabilities arising from your use of these resources. Renesas' products are provided only subject to Renesas' Terms and Conditions of Sale or other applicable terms agreed to in writing. No use of any Renesas resources expands or otherwise alters any applicable warranties or warranty disclaimers for these products.

(Disclaimer Rev.1.01 Jan 2024)

Corporate Headquarters

TOYOSU FORESIA, 3-2-24 Toyosu,
Koto-ku, Tokyo 135-0061, Japan
www.renesas.com

Trademarks

Renesas and the Renesas logo are trademarks of Renesas Electronics Corporation. All trademarks and registered trademarks are the property of their respective owners.

Contact Information

For further information on a product, technology, the most up-to-date version of a document, or your nearest sales office, please visit www.renesas.com/contact-us/.