

FEATURES

- 4 channel CODEC with on-chip digital filters
- Selectable A-law or  $\mu$ -law companding
- Master clock frequency selection: 2.048 MHz, 4.096 MHz or 8.192 MHz  
- Internal timing automatically adjusted based on MCLK and frame sync signal
- Separate PCM and master clocks
- Single PCM port with up to 8.192 MHz data rate (128 time slots)
- Transhybrid balance impedance hardware adjustable via external components
- Transmit gains hardware adjustable via external components
- Low power +5.0 V CMOS technology
- +5.0 V single power supply
- Package available: 32 pin PLCC, 44 pin TQFP

DESCRIPTION

The IDT821024 is a single-chip, four channel PCM CODEC with on-chip filters. The device provides analog-to-digital and digital-to-analog conversions and supports both a-law and  $\mu$ -law companding. The digital filters in IDT821024 provides the necessary transmit and receive filtering for voice telephone circuit to interface with time-division multiplexed systems. All of the digital filters are performed in digital signal processors operating from an internal clock, which is derived from MCLK. The fixed filters set the transmit and receive gain and frequency response.

In the IDT821024 the PCM data is transmitted to and received from the PCM highway in time slots determined by the individual Frame Sync signals ( $FSR_n$  and  $FSX_n$ , where  $n = 1-4$ ) at rates from 256 KHz to 8.192 MHz. Both Long and Short Frame Sync modes are available in the IDT821024.

The IDT821024 can be used in digital telecommunication applications such as PBX, Central Office Switch, Digital Telephone and Integrated Voice/Data Access Unit.

FUNCTIONAL BLOCK DIAGRAM

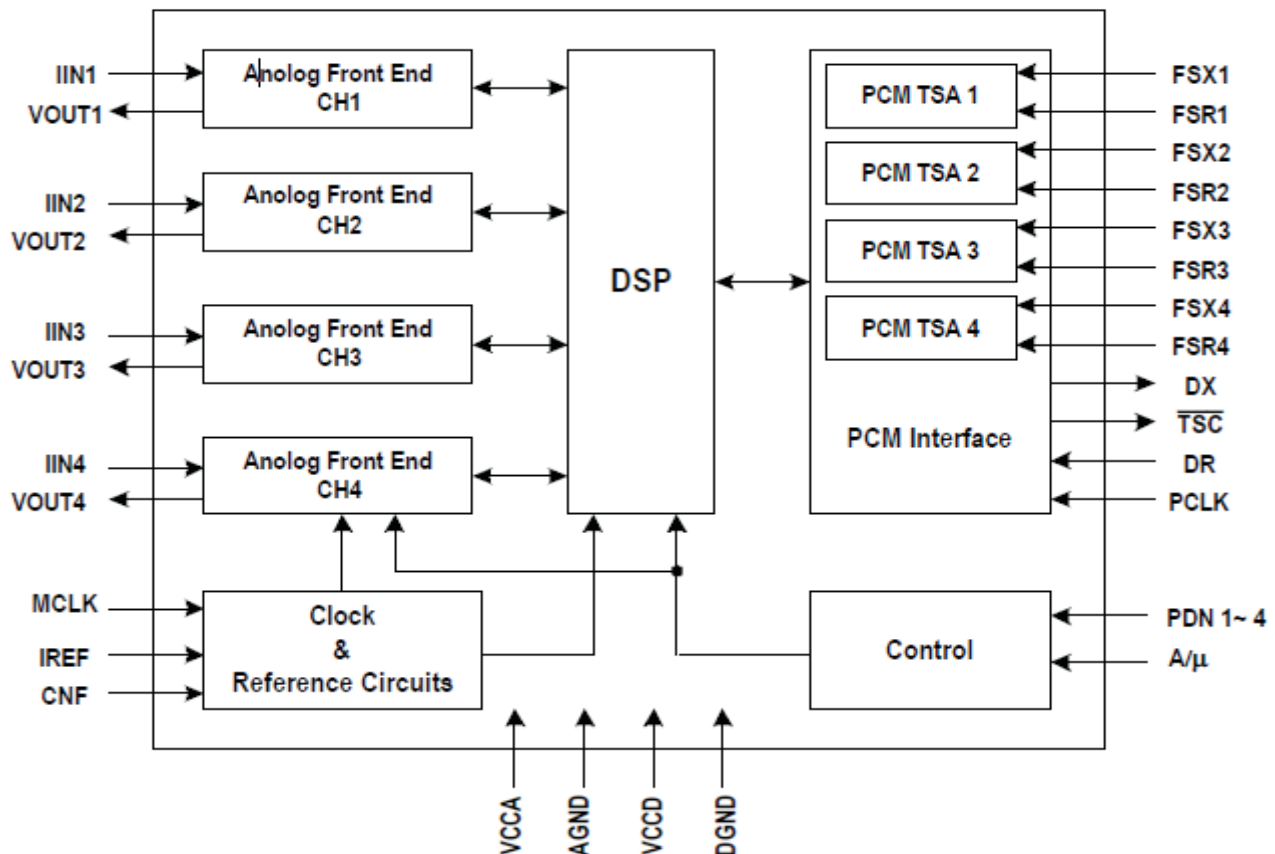



## PIN DESCRIPTION

Name	I/O	Pin Number		Description
		PLCC	TQFP	
AGND	--	10	7	<b>Analog Ground.</b> All ground pins should be connected to the ground plane of the circuit board.
VCCA	--	8	5	<b>+5 V Analog Power Supply.</b> All power supply pins should be connected to the power plane of the circuit board.
DGND	--	27	30	<b>Digital Ground.</b> All ground pins should be connected to the ground plane of the circuit board.
VCCD	--	25	27	<b>+5 V Digital Power Supply.</b> All power supply pins should be connected to the power plane of the circuit board.
DR	I	24	26	<b>Receive PCM Data Input.</b> The PCM data for Channel 1, 2, 3 and 4 is shifted serially into DR pin by the Receive Frame Sync Signal (FSR) with MSB first. A byte of data for each channel is received every 125 $\mu$ s at the PCLK rate.
DX	O	26	28	<b>Transmit PCM Data Output.</b> The PCM data for Channel 1, 2, 3 and 4 is shifted serially out to the DX pin by the Transmit Frame Sync Signal (FSX) with MSB first. A byte of data for each channel is transmitted every 125 $\mu$ s at the PCLK rate. DX is high impedance between time slots.
FSR1 FSR2 FSR3 FSR4	I	23 21 19 17	25 23 21 19	<b>Receive Frame Sync Input for Channel 1/2/3/4</b> This 8kHz signal pulse identifies the receive time slot for Channel N on a system's receive PCM frame. It must be synchronized to PCLK.
FSX1 FSX2 FSX3 FSX4	I	22 20 18 16	24 22 20 18	<b>Transmit Frame Sync Input for Channel 1/2/3/4</b> This 8 kHz signal pulse identifies the transmit time slot for Channel N on a system's transmit PCM frame. It must be synchronized to PCLK.
IREF	O	9	6	<b>Reference Current.</b> The IREF output is biased at the internal reference voltage. A resistor placed from IREF to ground sets the reference current used by the analog-to-digital converter to encode the signal current present on IINn pin (n is channel number, n = 1 to 4) into digital form.
VOUT1 VOUT2 VOUT3 VOUT4	O	4 7 11 14	43 2 10 13	<b>Voice Frequency Receiver Output for Channel 1/2/3/4</b> This is the output of receiver amplifier for Channel N. The received digital data from DR is processed and converted to an analog signal at this pin.
IIN1 IIN2 IIN3 IIN4	I	5 6 12 13	44 1 11 12	<b>Voice Frequency Transmitter Input for Channel 1/2/3/4</b> This is the input to the gain setting amplifier in the transmit path for Channel N. The analog voice band voltage signal is applied to this pin through a resistor. This input is a virtual AC ground input, which is biased at the IREF pin.
MCLK	I	30	35	<b>Master Clock.</b> The Master Clock provides the clock for the DSP. It can be either 2.048 MHz or 4.096 MHz. The IDT821024 determines the MCLK frequency via the FSX inputs and makes the necessary internal adjustments automatically. The MCLK frequency must be an integer multiple of the FSX frequency.
PCLK	I	29	34	<b>PCM Clock.</b> The PCM Clock shifts out the PCM data to the DX pin and shifts in PCM data from the DR pin. The PCM clock frequency is an integer multiple of the frame sync frequency. When PCLK is connected to MCLK, the PCM clock can generate the DSP clock as well.
$\overline{\text{TSC}}$	O	28	31	<b>Time Slot Control.</b> This open drain output is low active. When the PCM data is transmitted to the DX pin for any of the four channels, this pin will be pulled low.
A/ $\mu$	I	15	16	<b>A/<math>\mu</math>-Law Selection.</b> When this pin is low, $\mu$ -Law is selected; when this pin is high, A-Law is selected. This pin can be connected to VCCD or DGND pin directly.

## PIN DESCRIPTION (cont'd)

Name	IO	Pin Number		Description
		PLCC	TQFP	
PDN1 PDN2 PDN3 PDN4	I	2 1 32 31	39 38 37 36	Channel 1/2/3/4 Power Down. When this pin is high, Channel N is powered down.
CNF	O	3	41	Capacitor For Noise Filter. This pin should be connected to AGND through a 0.1μF capacitor.
NC	--		3, 4, 8, 9, 14, 15, 17, 29, 32, 33, 40, 42	No connection

## FUNCTIONAL DESCRIPTION

The IDT821024 contains four channel PCM CODEC with on chip digital filters. It provides the four-wire solution for the subscriber line circuitry in digital switches. The device converts analog voice signal to digital PCM data, and converts digital PCM data back to analog signal. Digital filters are used to bandlimit the voice signals during the conversion. Either A-law or  $\mu$ -law is supported by the IDT821024. The law selection is performed by A/ $\mu$  pin.

The frequency of the master clock (MCLK) can be 2.048 MHz, 4.096 MHz, or 8.192 MHz. Internal circuitry determines the master clock frequency automatically.

The serial PCM data for four channels are time multiplexed via two pins, DX and DR. The time slots of the four channels are determined by the individual Frame Sync signals at rates from 256 kHz to 8.192 MHz. For each channel, the IDT821024 provides a transmit Frame Sync signal and a receive Frame Sync signal.

Each channel of the IDT821024 can be powered down independently to save power consumption. The Channel Power Down Pins PDN1-4 configure channels to be active (power-on) or standby (power-down) separately.

### Signal Processing

High performance oversampling Analog-to-Digital Converters (ADC) and Digital-to-Analog Converters (DAC) are used in the IDT821024 to provide the required conversion accuracy. The associated decimation and interpolation filtering are realized with both dedicated hardware and Digital Signal Processor (DSP). The DSP also handles all other necessary functions such as PCM bandpass filtering and sample rate conversion.

### Transmit Signal Processing

In the transmit path, the analog input signal is received by the ADC and converted into digital data. The digital output of the oversampling ADC is decimated and sent to the DSP. The transmit filter is implemented in the DSP as a digital bandpass filter. The filtered signal is further decimated and compressed to PCM format.

### Transmit PCM Interface

The transmit PCM interface clocks out 1 byte (8 bits) PCM data out of DX pin every 125  $\mu$ s. The transmit logic, synchronized by the Transmit Frame Sync signal (FSXn), controls the data transmission. The FSXn pulse identifies the transmit time slot of the PCM frame for Channel N. The PCM Data is transmitted serially on DX pin with the Most Significant Bit (MSB) first. When the PCM data is being output on DX pin, the  $\overline{TSC}$  signal will be pulled low.

### Receive Signal Processing

In the receive path, the PCM code is received at the rate of 8,000 samples per second. The PCM code is expanded and sent to the DSP for interpolation. A receive filter is implemented in the DSP as a digital lowpass filter. The filtered signal is then sent to an oversampling DAC. The DAC output is post-filtered and delivered at VOUT pin by an amplifier. The amplifier can drive resistive load higher than 2 K $\Omega$ .

### Receive PCM Interface

The receive PCM interface clocks 1 byte (8 bits) PCM data into DR pin every 125  $\mu$ s. The receive logic, synchronized by the Receive Frame Sync signal (FSRn), controls the data receiving process. The FSRn pulse identifies the receive time slot of the PCM frame for Channel N. The PCM Data is received serially on DR pin with the Most Significant Bit (MSB) first.

### Hardware Gain Setting In Transmit Path

The transmit gain of the IDT821024 for each channel can be set by 2 resistors, R<sub>REF</sub> and R<sub>TXn</sub> (as shown in Figure 1), according to the following equation:

$$G_t = \frac{3 \times R_{REF}}{R_{TXn}}$$

The receive gain of IDT821024 is fixed and equal to 1.

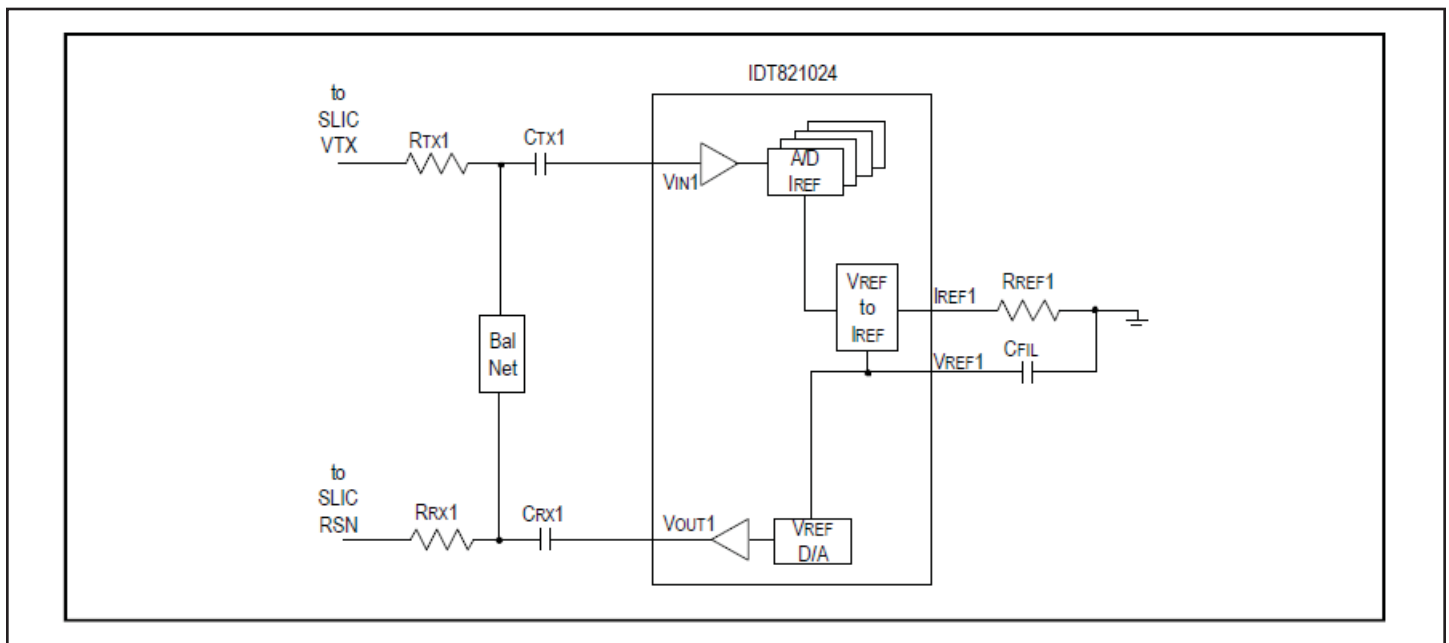

Figure 1. IDT821024 Transmit Gain Setting for Channel 1

## OPERATING THE IDT821024

The following descriptions about operation applies to all four channels of the IDT821024.

### Power-on Sequence and Master Clock Configuration

To power on the IDT821024 users should follow this sequence:

1. Apply ground;
2. Apply VCC, finish signal connections;
3. Set PDN1-4 pins high, thus all of the 4 channels are powered down;

The master clock (MCLK) frequency of IDT821024 can be configured as 2.048 MHz, 4.096 MHz or 8.192 MHz. Using the Transmit Frame Sync (FSX) inputs, the device determines the MCLK frequency and makes the necessary internal adjustments automatically. The MCLK frequency must be an integer multiple of the Frame Sync frequency.

### Operating Modes

There are two operating modes for each transmit or receive channel: standby mode (when the channel is powered down) and normal mode (when the channel is powered on). The mode selection of each channel is done by its corresponding PDN pin. When PDN<sub>n</sub> is 1, Channel N is in standby mode; when PDN<sub>n</sub> is 0, Channel N is in normal mode.

In standby mode, all circuits are powered down with the analog outputs placed in high impedance state.

In normal mode, each channel of the IDT821024 is able to transmit and receive both PCM and analog information. The normal mode is used when a telephone call is in progress.

### Companding Law Selection

An A/ $\mu$  pin is provided by IDT821024 for the companding law selection. When this pin is low,  $\mu$ -law is selected; when the pin is high, A-law is selected.

## ABSOLUTE MAXIMUM RATINGS

Rating	Com'l & Ind'l	Unit
Power Supply Voltage	≤ 6.5	V
Voltage on Any Pin with Respect to Ground	-0.5 to 5.5	V
Package Power Dissipation	≤ 600	mW
Storage Temperature	-65 to +150	°C

NOTE: Stresses greater than those listed under ABSOLUTE MAXIMUM RATINGS may cause permanent damage to the device. This is a stress rating only and functional operation of the device at these or any other conditions above those indicated in the operational sections of this specification is not implied. Exposure to absolute maximum rating conditions for extended periods may affect reliability.

## RECOMMENDED DC OPERATING CONDITIONS

Parameter	Min.	Typ.	Max.	Unit
Operating Temperature	-40		+85	°C
Power Supply Voltage	4.75		5.25	V

NOTE: MCLK: 2.048 MHz, 4.096 MHz or 8.192 MHz with tolerance of ± 50 ppm

## ELECTRICAL CHARACTERISTICS

### Digital Interface

Parameter	Description	Min	Typ	Max	Units	Test Conditions
V <sub>IL</sub>	Input Low Voltage			0.8	V	All digital inputs
V <sub>IH</sub>	Input High Voltage	2.0			V	All digital inputs
V <sub>OL</sub>	Output Low Voltage			0.4	V	DX, TSC, I <sub>L</sub> = 14mA
				0.8	V	All other digital outputs, I <sub>L</sub> = 4mA
				0.2	V	All digital pins, I <sub>L</sub> = 14mA
V <sub>OH</sub>	Output High Voltage	VDD-0.6			V	DX, I <sub>H</sub> = -7 mA, all other outputs, I <sub>H</sub> = -4 mA
		VDD-0.2			V	All digital pins, I <sub>H</sub> = -1mA
I <sub>I</sub>	Input Current	-10		10	μA	Any digital inputs GND < V <sub>IN</sub> < VDD
I <sub>OZ</sub>	Output Current in High-impedance State	-10		10	μA	DX
C <sub>I</sub>	Input Capacitance			5	pF	

Note: Total current must not exceed absolute maximum ratings.

### Power Dissipation

Parameter	Description	Min	Typ	Max	Units	Test Conditions
PD <sub>2</sub>	Operating Power Dissipation 1		180	240	mW	All channels are active
PD <sub>1</sub>	Operating Power Dissipation 1		60	90	mW	Only one channel is active
PD <sub>0</sub>	Standby Power Dissipation		4	10	mW	All channels are powered down with only MCLK present

Note: Power measurements are made at MCLK = 4.096 MHz, outputs unloaded

### Analog Interface

Parameter	Description	Min	Typ	Max	Units	Test Conditions
V <sub>OUT1</sub>	Output Voltage	2.25	2.4	2.6	V	Alternating ± zero μ-law PCM code applied to DR.
V <sub>OUT2</sub>	Output Voltage Swing	3.25			V P-P	R <sub>L</sub> = 2000Ω
R <sub>O</sub>	Output Resistance		1	4	Ω	0dBm0, 1020Hz PCM code applied to DR
R <sub>L</sub>	Load Resistance	2000			Ω	External loading
I <sub>IR</sub>	Analog Input Current Range		±40		μA	R <sub>REF</sub> = 13kΩ
I <sub>IOS</sub>	Offset Current Allowed on IIN	-1.6		+1.6	μA	
I <sub>OUT</sub>	VOUT Output Current (F < 3400Hz)	-5		5	mA	
I <sub>Z</sub>	Output Leakage Current	-10		10	μA	Power down
C <sub>L</sub>	Load Capacitance			100	pF	External loading

## TRANSMISSION CHARACTERISTICS

0dBm0 is defined as 0.6832Vrms for A-law and 0.6778 Vrms for A-law, both for 600 Ω load. Unless otherwise noted, the analog input is a 0 dBm0, 1020 Hz sine wave; the input amplifier is set for unity gain. The digital input is a PCM bit stream equivalent to that obtained by passing a 0 dBm0, 1020 Hz sine wave through an ideal encoder. The output level is sin(x)/x-corrected. Typical value are tested at VDD = 5V and TA = 25°C.

### Absolute Gain

Parameter	Description	Min	Typ	Max	Units	Test Conditions
<b>G<sub>XA</sub></b>	Transmit Gain, Absolute 0°C to 85°C -40°C	-0.25 -0.35		0.25 0.35	dB dB	Signal input of 0 dBm0, μ-law or A-law
<b>G<sub>RA</sub></b>	Receive Gain, Absolute 0°C to 85°C -40°C	-0.25 -0.35		0.25 0.35	dB dB	Measured relative to 0 dBm0, μ-law or A-law, PCM input of 0 dBm0 1020 Hz, R <sub>L</sub> = 10 kΩ

### Gain Tracking

Parameter	Description	Min	Typ	Max	Units	Test Conditions
<b>GT<sub>X</sub></b>	Transmit Gain Tracking +3 dBm0 to -40 dBm0 -40 dBm0 to -50 dBm0 -50 dBm0 to -55 dBm0	-0.10 -0.25 -0.50		0.10 0.50 0.50	dB dB dB	Tested by Sinusoidal Method, μ-law/A-law
<b>GT<sub>R</sub></b>	Receive Gain Tracking +3 dBm0 to -40 dBm0 -40 dBm0 to -50 dBm0 -50 dBm0 to -55 dBm0	-0.10 -0.25 -0.50		0.10 0.50 0.50	dB dB dB	Tested by Sinusoidal Method, μ-law/A-law

### Frequency Response

Parameter	Description	Min	Typ	Max	Units	Test Conditions
<b>G<sub>XR</sub></b>	Transmit Gain, Relative to G <sub>XA</sub> f = 50 Hz f = 60 Hz f = 300 Hz to 3400 Hz f = 3600 Hz f = 4600 Hz and above	-0.15		-40 -40 0.15 -0.1 -35	dB dB dB dB dB	
<b>G<sub>RR</sub></b>	Receive Gain, Relative to G <sub>RA</sub> f below 300 Hz f = 300 Hz to 3400 Hz f = 3600 Hz f = 4600 Hz and above	-0.15		0 0.15 -0.2 -35	dB dB dB dB	

### Group Delay

Parameter	Description	Min	Typ	Max	Units	Test Conditions
<b>D<sub>XA</sub></b>	Transmit Delay, Absolute *			340	μs	
<b>D<sub>XR</sub></b>	Transmit Delay, Relative to 1800 Hz f = 500 Hz – 600 Hz f = 600 Hz – 1000 Hz f = 1000 Hz – 2600 Hz f = 2600 Hz – 2800 Hz			280 150 80 280	μs μs μs μs	
<b>D<sub>RA</sub></b>	Receive Delay, Absolute *			260	μs	
<b>D<sub>RR</sub></b>	Receive Delay, Relative to 1800 Hz f = 500 Hz – 600 Hz f = 600 Hz – 1000 Hz f = 1000 Hz – 2600 Hz f = 2600 Hz – 2800 Hz			50 80 120 150	μs μs μs μs	

Note\*: Minimum value in transmit and receive path.



Distortion

Parameter	Description	Min	Typ	Max	Units	Test Conditions
<b>STD<sub>x</sub></b>	Transmit Signal to Total Distortion Ratio					ITU-T O.132 Sine Wave Method, Psophometric Weighted for A-law, C Message Weighted for $\mu$ -law.
	A-law :					
	Input level = 0 dBm0	36			dB	
	Input level = -30 dBm0	36			dB	
	Input level = -40 dBm0	30			dB	
	Input level = -45 dBm0	24			dB	
	$\mu$ -law :					
	Input level = 0 dBm0	36			dB	
<b>STD<sub>R</sub></b>	Receive Signal to Total Distortion Ratio					ITU-T O.132 Sine Wave Method, Psophometric Weighted for A-law; Sine Wave Method, C Message Weighted for $\mu$ -law;
	A-law :					
	Input level = 0 dBm0	36			dB	
	Input level = -30 dBm0	36			dB	
	Input level = -40 dBm0	30			dB	
	Input level = -45 dBm0	24			dB	
	$\mu$ -law :					
	Input level = 0 dBm0	36			dB	
<b>SFD<sub>x</sub></b>	Single Frequency Distortion, Transmit			-42	dBm0	200 Hz - 3400 Hz, 0 dBm0 input, output any other single frequency $\leq$ 3400 Hz
	Single Frequency Distortion, Receive			-42	dBm0	200 Hz - 3400 Hz, 0 dBm0 input, output any other single frequency $\leq$ 3400 Hz
<b>IMD</b>	Intermodulation Distortion			-42	dBm0	Transmit or receive, two frequencies in the range (300 Hz– 3400 Hz) at -6 dBm0

Noise

Parameter	Description	Min	Typ	Max	Units	Test Conditions
<b>N<sub>x</sub>C</b>	Transmit Noise, C Message Weighted for $\mu$ -law			16	dBmC0	
<b>N<sub>x</sub>P</b>	Transmit Noise, Psophometric Weighted for A-law			-68	dBm0p	
<b>N<sub>R</sub>C</b>	Receive Noise, C Message Weighted for $\mu$ -law			12	dBmC0	
<b>N<sub>R</sub>P</b>	Receive Noise, Psophometric Weighted for A-law			-78	dBm0p	
<b>N<sub>RS</sub></b>	Noise, Single Frequency f = 0 kHz – 100 kHz			-53	dBm0	IIN = 0 A, tested at VOUT
<b>PSR<sub>x</sub></b>	Power Supply Rejection Transmit f = 300 Hz – 3.4 kHz	40			dB	VDD = 5.0 VDC + 100 mVrms
	f = 3.4 kHz – 20 kHz	25			dB	
<b>PSR<sub>R</sub></b>	Power Supply Rejection Receive f = 300 Hz – 3.4 kHz	40			dB	PCM code is positive one LSB, VDD = 5.0 VDC + 100 mVrms
	f = 3.4 kHz – 20 kHz	25			dB	
<b>SOS</b>	Spurious Out-of-Band Signals at VOUT Relative to Input PCM code applied:					0 dBm0, 300 Hz – 3400 Hz input
	4600 Hz – 20 kHz			-40	dB	
	20 kHz – 50 kHz			-30	dB	

### Interchannel Crosstalk

Parameter	Description	Min	Typ	Max	Units	Test Conditions
$XT_{X-R}$	Transmit to Receive Crosstalk		-85	-78	dB	300 Hz – 3400 Hz, 0 dBm0 signal into IIN of interfering channel. Idle PCM code into channel under test.
$XR_{R-X}$	Receive to Transmit Crosstalk		-85	-80	dB	300 Hz – 3400 Hz, 0 dBm0 PCM code into interfering channel. IIN = 0 A for channel under test.
$XT_{X-X}$	Transmit to Transmit Crosstalk		-85	-78	dB	300 Hz – 3400 Hz, 0 dBm0 signal into IIN of interfering channel. IIN = 0 A for channel under test.
$XR_{R-R}$	Receive to Receive Crosstalk		-85	-80	dB	300 Hz – 3400 Hz, 0 dBm0 PCM code into interfering channel. Idle PCM code into channel under test.

### Intrachannel Crosstalk

Parameter	Description	Min	Typ	Max	Units	Test Conditions
$XT_{X-R}$	Transmit to Receive Crosstalk		-80	-70	dB	300 Hz – 3400 Hz, 0 dBm0 signal into IIN. Idle PCM code into DR.
$XR_{R-X}$	Receive to Transmit Crosstalk		-80	-70	dB	300 Hz – 3400 Hz, 0 dBm0 PCM code into DR. IIN = 0 A.

## TIMING CHARACTERISTICS

### Clock

Parameter	Description	Min	Typ	Max	Units	Test Conditions
t1	PCLK Duty Cycle	40		60	%	PCLK=512kHz to 8.192MHz
t2	PCLK Rise and Fall Time			25	ns	PCLK=512kHz to 8.192MHz
t3	MCLK Duty Cycle	40		60	%	MCLK=2.048Hz,4.096MHz or 8.192MHz
t4	MCLK Rise and Fall Time			15	ns	MCLK=2.048Hz,4.096MHz or 8.192MHz
t5	PCLK Clock Period	244			ns	PCLK=512kHz to 8.192MHz

### Transmit

Parameter	Description	Min	Typ	Max	Units	Test Conditions
t11	Data Output Delay Time (for Short Frame Sync Mode)	5		70	ns	
t12	Data Hold Time	5		70	ns	
t13	Data Delay to High-Z	50		220 t5+70	ns	
t14	Frame sync Hold Time	50			ns	
t15	Frame sync High Setup Time	55		t5-50	ns	
t16	TSC Enable Delay Time(for Short Frame Sync Mode)	5		80	ns	
t17	TSC Disable Delay Time	50		220 t5+70	ns	
t18	Data Output Delay Time(for Long Frame Sync Mode)	5		40	ns	
t19	TSC Enable Delay Time(for Long Frame Sync Mode)	5		40	ns	
t21	Receive Data Setup Time	25			ns	
t22	Receive Data Hold Time	5			ns	

Note: Timing parameter t13 is referenced to a high-impedance state.

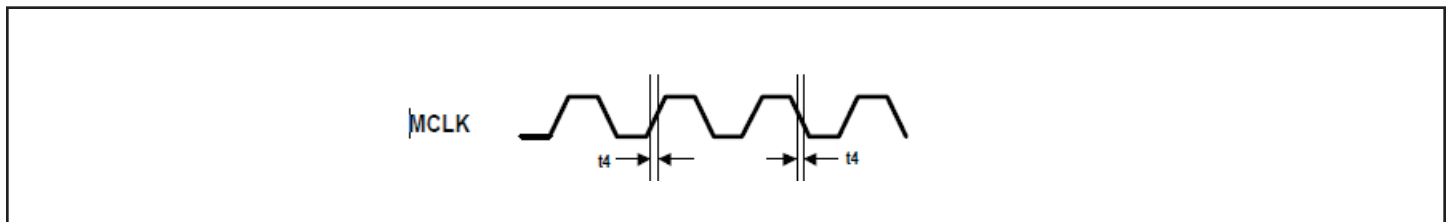

Figure 2. MCLK Timing

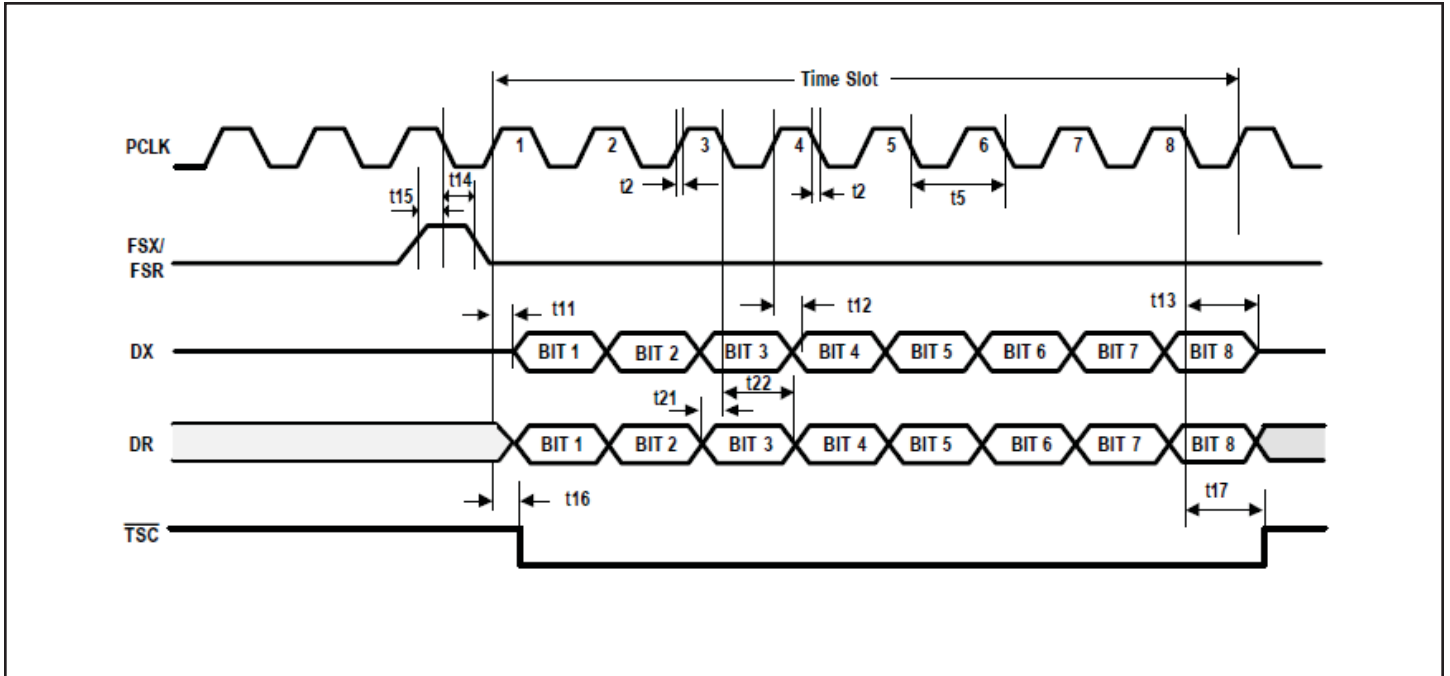

Figure 3. PCM Interface Timing for Short Frame Mode

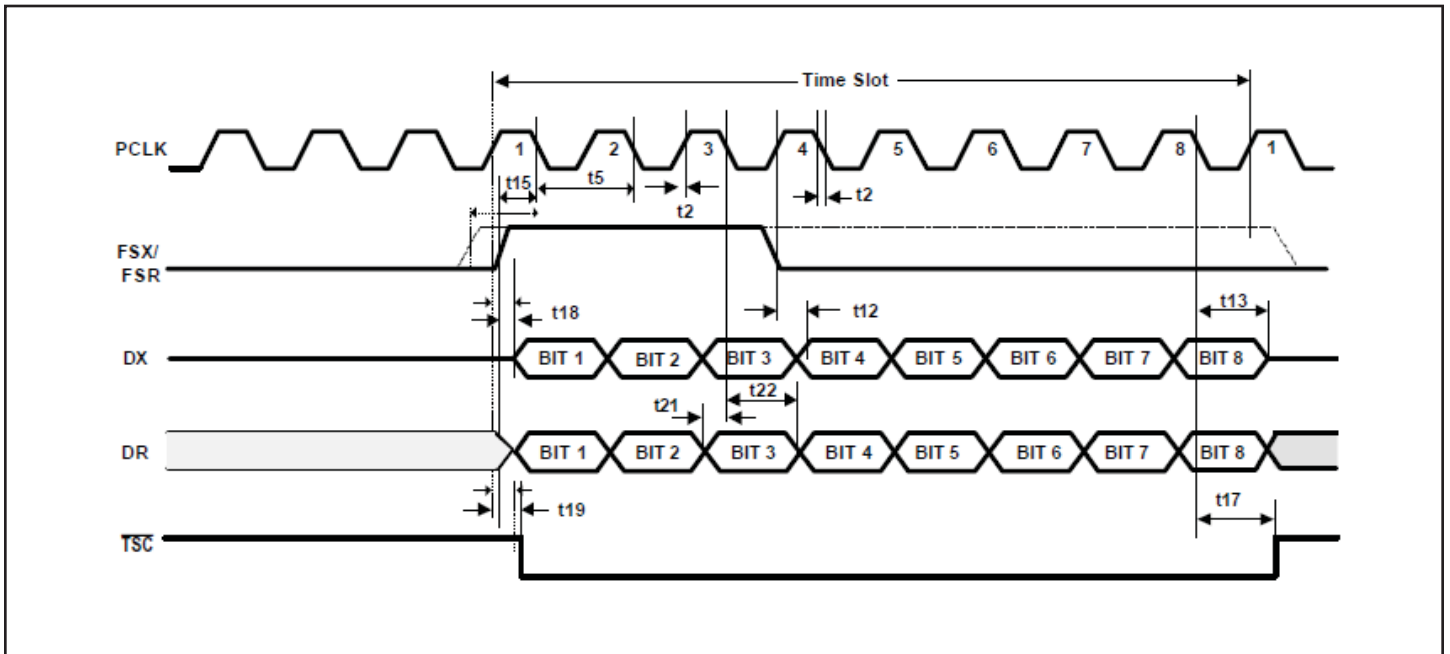
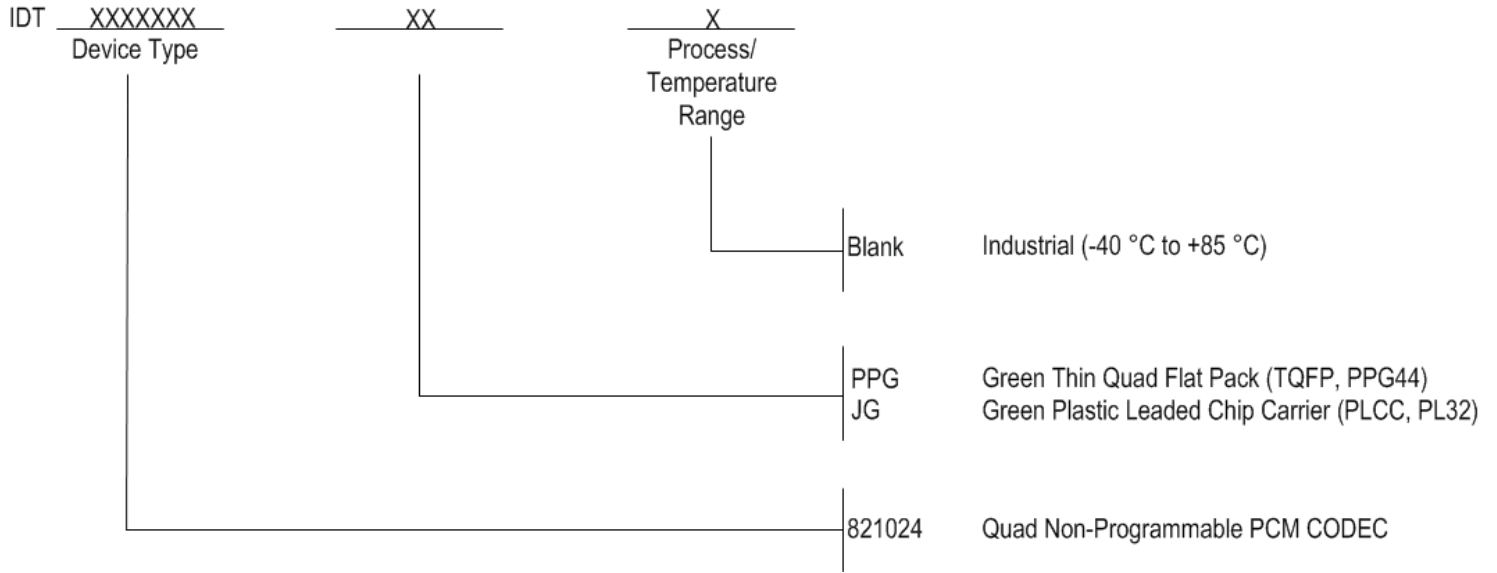

Figure 4. PCM Interface Timing for Long Frame Mode

ORDERING INFORMATION



**Data Sheet Document History**

01/16/2002	pgs. 4, 5
02/21/2002	pgs. 1-4, 13
09/10/2002	pg. 8
01/08/2003	pgs. 1, 13
04/03/2003	pg. 1
06/25/2014	821024PP package Product Discontinuation Notice - Last time buy expires 7/26/14, PDN CQ-13-01 Changed Datasheet format Added Contacts page



## IMPORTANT NOTICE AND DISCLAIMER

RENESAS ELECTRONICS CORPORATION AND ITS SUBSIDIARIES (“RENESAS”) PROVIDES TECHNICAL SPECIFICATIONS AND RELIABILITY DATA (INCLUDING DATASHEETS), DESIGN RESOURCES (INCLUDING REFERENCE DESIGNS), APPLICATION OR OTHER DESIGN ADVICE, WEB TOOLS, SAFETY INFORMATION, AND OTHER RESOURCES “AS IS” AND WITH ALL FAULTS, AND DISCLAIMS ALL WARRANTIES, EXPRESS OR IMPLIED, INCLUDING, WITHOUT LIMITATION, ANY IMPLIED WARRANTIES OF MERCHANTABILITY, FITNESS FOR A PARTICULAR PURPOSE, OR NON-INFRINGEMENT OF THIRD PARTY INTELLECTUAL PROPERTY RIGHTS.

These resources are intended for developers skilled in the art designing with Renesas products. You are solely responsible for (1) selecting the appropriate products for your application, (2) designing, validating, and testing your application, and (3) ensuring your application meets applicable standards, and any other safety, security, or other requirements. These resources are subject to change without notice. Renesas grants you permission to use these resources only for development of an application that uses Renesas products. Other reproduction or use of these resources is strictly prohibited. No license is granted to any other Renesas intellectual property or to any third party intellectual property. Renesas disclaims responsibility for, and you will fully indemnify Renesas and its representatives against, any claims, damages, costs, losses, or liabilities arising out of your use of these resources. Renesas' products are provided only subject to Renesas' Terms and Conditions of Sale or other applicable terms agreed to in writing. No use of any Renesas resources expands or otherwise alters any applicable warranties or warranty disclaimers for these products.

(Rev.1.0 Mar 2020)

### Corporate Headquarters

TOYOSU FORESIA, 3-2-24 Toyosu,  
Koto-ku, Tokyo 135-0061, Japan  
[www.renesas.com](http://www.renesas.com)

### Contact Information

For further information on a product, technology, the most up-to-date version of a document, or your nearest sales office, please visit:  
[www.renesas.com/contact/](http://www.renesas.com/contact/)

### Trademarks

Renesas and the Renesas logo are trademarks of Renesas Electronics Corporation. All trademarks and registered trademarks are the property of their respective owners.