

General Description

The 810251I is a high performance, low jitter/low phase noise VCXO. The 810251I uses a low frequency and low cost pullable crystal to achieve jitter attenuation for synchronous Ethernet applications. The 810251I can take an input of either 25MHz or 125MHz and produce a single LVCMOS output of 25MHz.

The device is packaged in a small 16 lead TSSOP package and is ideal for use on space constrained boards typically encountered in most synchronous ethernet applications.

Applications

- Synchronous Ethernet v0.39a
- End equipment compliant with Std IEEE 802.039a

Features

- One single-ended output (LVCMOS or LVTTTL levels), output Impedance: 15Ω
- Phase jitter attenuation by the VCXO-PLL using a 25MHz pullable external crystal (XTAL)
- Input frequencies: 25MHz or 125MHz
- Output frequency: 25MHz
- PLL loop bandwidth adjustable by external components
- 25MHz or 125MHz auto input frequency detect
- Full 3.3V or 2.5V supply voltage
- -40°C to 85°C ambient operating temperature
- Available in lead-free (RoHS 6) package

Block Diagram

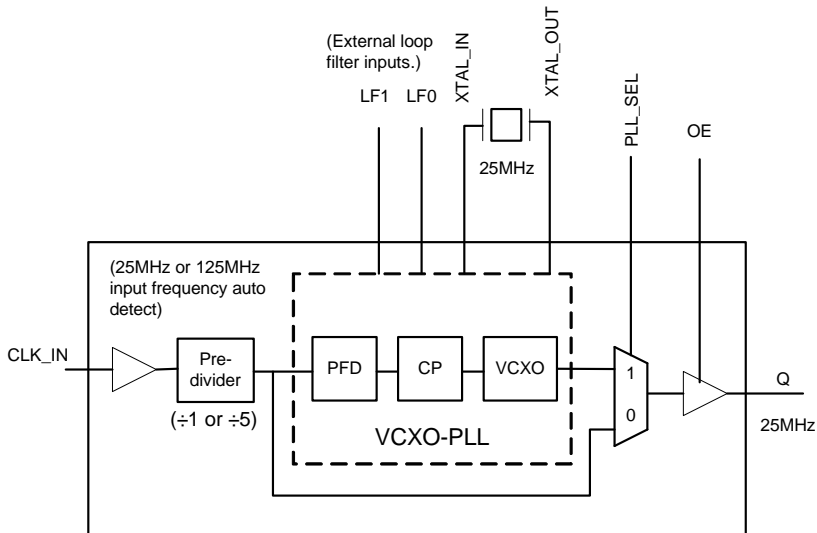

Pin Assignment

PLL_SEL	1	16	CLK_IN
GND	2	15	V _{DD}
Reserved	3	14	LF1
Q	4	13	LF0
V _{DDO}	5	12	GND
OE	6	11	XTAL_IN
V _{DDA}	7	10	XTAL_OUT
V _{DD}	8	9	GND

810251I

16-Lead TSSOP
4.4mm x 5.0mm x 0.925mm
package body
G Package
Top View

Table 1. Pin Descriptions

Number	Name	Type		Description
1	PLL_SEL	Input	Pullup	When logic HIGH, the VCXO-PLL is enabled. When LOW, the VCXO-PLL is in bypass mode. LVCMOS/LVTTL interface levels.
2, 9, 12	GND	Power		Power supply ground.
3	Reserved	Reserved		Reserved pin. Do not connect.
4	Q	Output		Single-ended clock output. LVCMOS/ LVTTL interface levels.
5	V _{DDO}	Power		Output power supply pin.
6	OE	Input	Pullup	Output enable pin for Q output. LVCMOS/LVTTL interface levels.
7	V _{DDA}	Power		Analog supply pin.
8, 15	V _{DD}	Power		Core supply pins.
10, 11	XTAL_OUT, XTAL_IN	Input		VCXO crystal oscillator interface. XTAL_IN is the input. XTAL_OUT is the output.
13, 14	LF0, LF1	Analog Input/ Output		Loop filter connection node pins.
16	CLK_IN	Input	Pulldown	Single-ended clock input. LVCMOS/LVTTL interface levels.

NOTE: *Pullup* and *Pulldown* refer to internal input resistors. See Table 2, *Pin Characteristics*, for typical values.

Table 2. Pin Characteristics

Symbol	Parameter	Test Conditions	Minimum	Typical	Maximum	Units
C _{IN}	Input Capacitance			4		pF
C _{PD}	Power Dissipation Capacitance	V _{DD} , V _{DDO} = 3.465V		8		pF
		V _{DD} , V _{DDO} = 2.625V		5		pF
R _{PULLUP}	Input Pullup Resistor			51		kΩ
R _{PULLDOWN}	Input Pulldown Resistor			51		kΩ
R _{OUT}	Output Impedance	V _{DDO} = 3.3V±5%		15		Ω
		V _{DDO} = 2.5V±5%		20		Ω

Absolute Maximum Ratings

NOTE: Stresses beyond those listed under *Absolute Maximum Ratings* may cause permanent damage to the device. These ratings are stress specifications only. Functional operation of product at these conditions or any conditions beyond those listed in the *DC Characteristics* or *AC Characteristics* is not implied. Exposure to absolute maximum rating conditions for extended periods may affect product reliability.

Item	Rating
Supply Voltage, V_{DD}	4.6V
Inputs, V_I	-0.5V to $V_{DD} + 0.5V$
Outputs, V_O	-0.5V to $V_{DD} + 0.5V$
Package Thermal Impedance, θ_{JA}	92.4°C/W (0 mps)
Storage Temperature, T_{STG}	-65°C to 150°C

DC Electrical Characteristics

Table 3A. Power Supply DC Characteristics, $V_{DD} = V_{DDO} = 3.3V \pm 5\%$, $T_A = -40^\circ\text{C}$ to 85°C

Symbol	Parameter	Test Conditions	Minimum	Typical	Maximum	Units
V_{DD}	Core Supply Voltage		3.135	3.3	3.465	V
V_{DDA}	Analog Supply Voltage		$V_{DD} - 0.07$	3.3	V_{DD}	V
V_{DDO}	Output Supply Voltage		3.135	3.3	3.465	V
I_{DD}	Power Supply Current				40	mA
I_{DDA}	Analog Supply Current				7	mA
I_{DDO}	Output Supply Current	No Load			5	mA

Table 3B. Power Supply DC Characteristics, $V_{DD} = V_{DDO} = 2.5V \pm 5\%$, $T_A = -40^\circ\text{C}$ to 85°C

Symbol	Parameter	Test Conditions	Minimum	Typical	Maximum	Units
V_{DD}	Core Supply Voltage		2.375	2.5	2.625	V
V_{DDA}	Analog Supply Voltage		$V_{DD} - 0.07$	2.5	V_{DD}	V
V_{DDO}	Output Supply Voltage		2.375	2.5	2.625	V
I_{DD}	Power Supply Current				35	mA
I_{DDA}	Analog Supply Current				7	mA
I_{DDO}	Output Supply Current	No Load			5	mA

Table 3C. LVCMOS/LVTTL DC Characteristics, $V_{DD} = V_{DDO} = 3.3V \pm 5\%$ or $2.5V \pm 5\%$, $T_A = -40^{\circ}C$ to $85^{\circ}C$

Symbol	Parameter		Test Conditions	Minimum	Typical	Maximum	Units
V_{IH}	Input High Voltage		$V_{DD} = 3.465V$	2		$V_{DD} + 0.3$	V
			$V_{DD} = 2.625V$	1.7		$V_{DD} + 0.3$	V
V_{IL}	Input Low Voltage		$V_{DD} = 3.465V$	-0.3		0.8	V
			$V_{DD} = 2.625V$	-0.3		0.7	V
I_{IH}	Input High Current	CLK_IN	$V_{DD} = V_{IN} = 3.465V$ or $2.625V$			150	μA
		OE, PLL_SEL	$V_{DD} = V_{IN} = 3.465V$ or $2.625V$			5	μA
I_{IL}	Input Low Current	CLK_IN	$V_{DD} = 3.465V$ or $2.625V$, $V_{IN} = 0V$	-5			μA
		OE, PLL_SEL	$V_{DD} = 3.465V$ or $2.625V$, $V_{IN} = 0V$	-150			μA
V_{OH}	Output High Voltage; NOTE 1		$V_{DDO} = 3.3V \pm 5\%$	2.6			V
			$V_{DDO} = 2.5V \pm 5\%$	1.8			V
V_{OL}	Output Low Voltage; NOTE 1		$V_{DDO} = 3.3V \pm 5\%$			0.6	V
			$V_{DDO} = 2.5V \pm 5\%$			0.5	V

NOTE 1: Outputs terminated with 50Ω to $V_{DDO}/2$. See Parameter Measurement Information section. *Load Test Circuit diagrams.*

AC Electrical Characteristics

Table 4A. AC Characteristics, $V_{DD} = V_{DDO} = 3.3V \pm 5\%$, $T_A = -40^{\circ}C$ to $85^{\circ}C$

Symbol	Parameter	Test Conditions	Minimum	Typical	Maximum	Units
f_{REF}	Input Reference Frequency			25		MHz
				125		MHz
f_{VCO}	VCXO-PLL Frequency			25		MHz
f_{OUT}	Output Frequency			25		MHz
$t_{JIT(CC)}$	Cycle-to-Cycle Jitter; NOTE 1				45	ps
$t_{jit(\theta)}$	RMS Phase Jitter (Random); NOTE 2	$f_{OUT} = 25MHz$, Integration Range: 1kHz – 1MHz		0.22		ps
$t_{JIT(PER)}$	Period jitter				5	ps
t_R / t_F	Output Rise/Fall Time	20% to 80%	500		1200	ps
odc	Output Duty Cycle; NOTE 3		48		52	%
odc	Output Duty Cycle; NOTE 4		45		55	%

NOTE: Electrical parameters are guaranteed over the specified ambient operating temperature range, which is established when device is mounted in a test socket with maintained transverse airflow greater than 500 lpm. Device will meet specifications after thermal equilibrium has been reached under these conditions.

NOTE: Characterized using a 616Hz bandwidth filter.

NOTE 1: This parameter is defined in accordance with JEDEC Standard 65.

NOTE 2: Please refer to the Phase Noise Plot.

NOTE 3: Specified with the VCXO-PLL free running high.

NOTE 4: Specified with the VCXO-PLL locked.

Table 4B. AC Characteristics, $V_{DD} = V_{DDO} = 2.5V \pm 5\%$, $T_A = -40^{\circ}C$ to $85^{\circ}C$

Symbol	Parameter	Test Conditions	Minimum	Typical	Maximum	Units
f_{REF}	Input Reference Frequency			25		MHz
				125		MHz
f_{VCO}	VCXO-PLL Frequency			25		MHz
f_{OUT}	Output Frequency			25		MHz
$t_{JIT(CC)}$	Cycle-to-Cycle Jitter; NOTE 1				35	ps
t_{jit}	RMS Phase Jitter (Random); NOTE 2	$f_{OUT} = 25MHz$, Integration Range: 1kHz – 1MHz		0.24		ps
$t_{JIT(PER)}$	Period jitter				10	ps
t_R / t_F	Output Rise/Fall Time	20% to 80%	700		2200	ps
odc	Output Duty Cycle; NOTE 3		48		52	%
odc	Output Duty Cycle; NOTE 4		44		56	%

NOTE: Electrical parameters are guaranteed over the specified ambient operating temperature range, which is established when device is mounted in a test socket with maintained transverse airflow greater than 500 lpm. Device will meet specifications after thermal equilibrium has been reached under these conditions.

NOTE: Characterized using a 616Hz bandwidth filter.

NOTE 1: This parameter is defined in accordance with JEDEC Standard 65.

NOTE 2: Please refer to the Phase Noise Plot.

NOTE 3: Specified with the VCXO-PLL free running high.

NOTE 4: Specified with the VCXO-PLL locked.

Typical Phase Noise at 25MHz (3.3V)

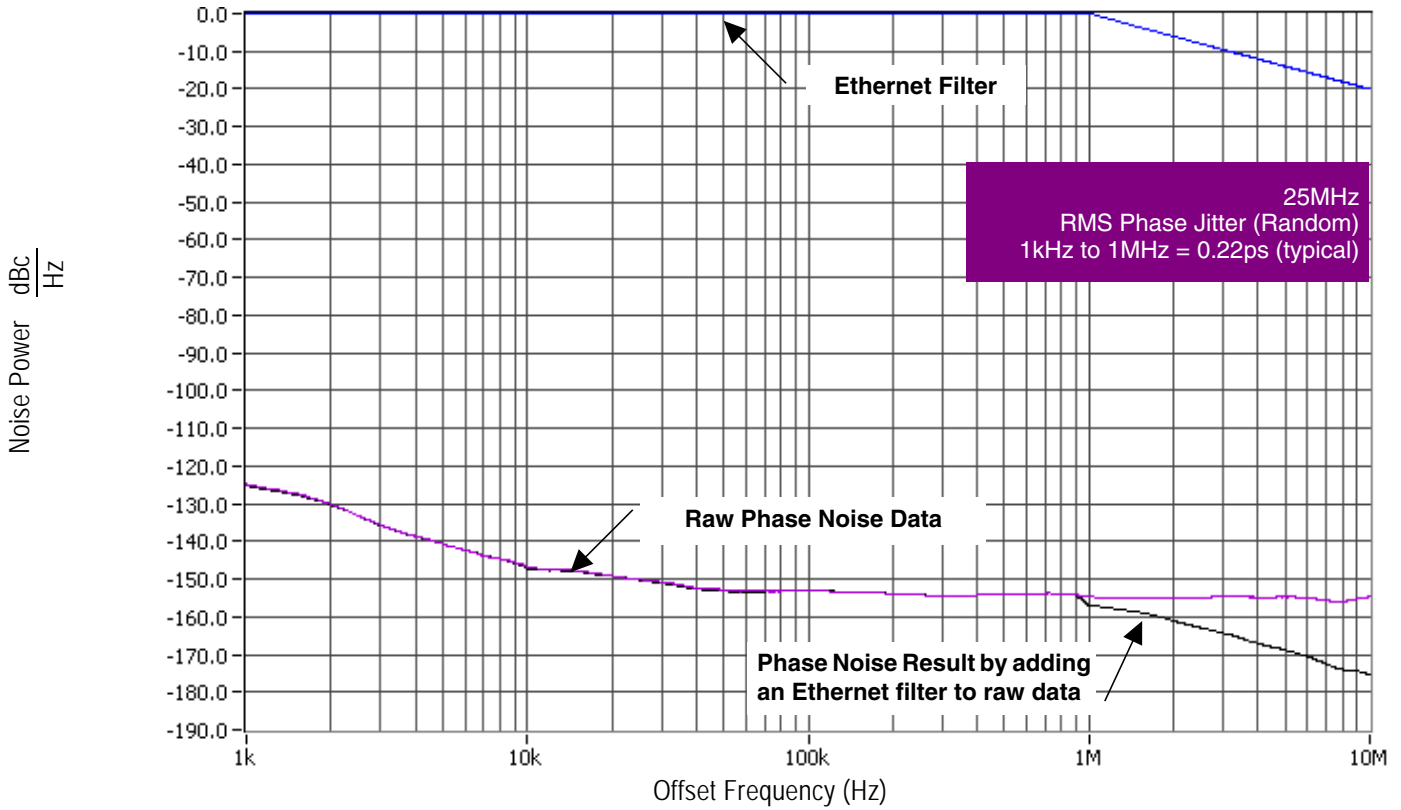

Typical Phase Noise at 25MHz (2.5V)

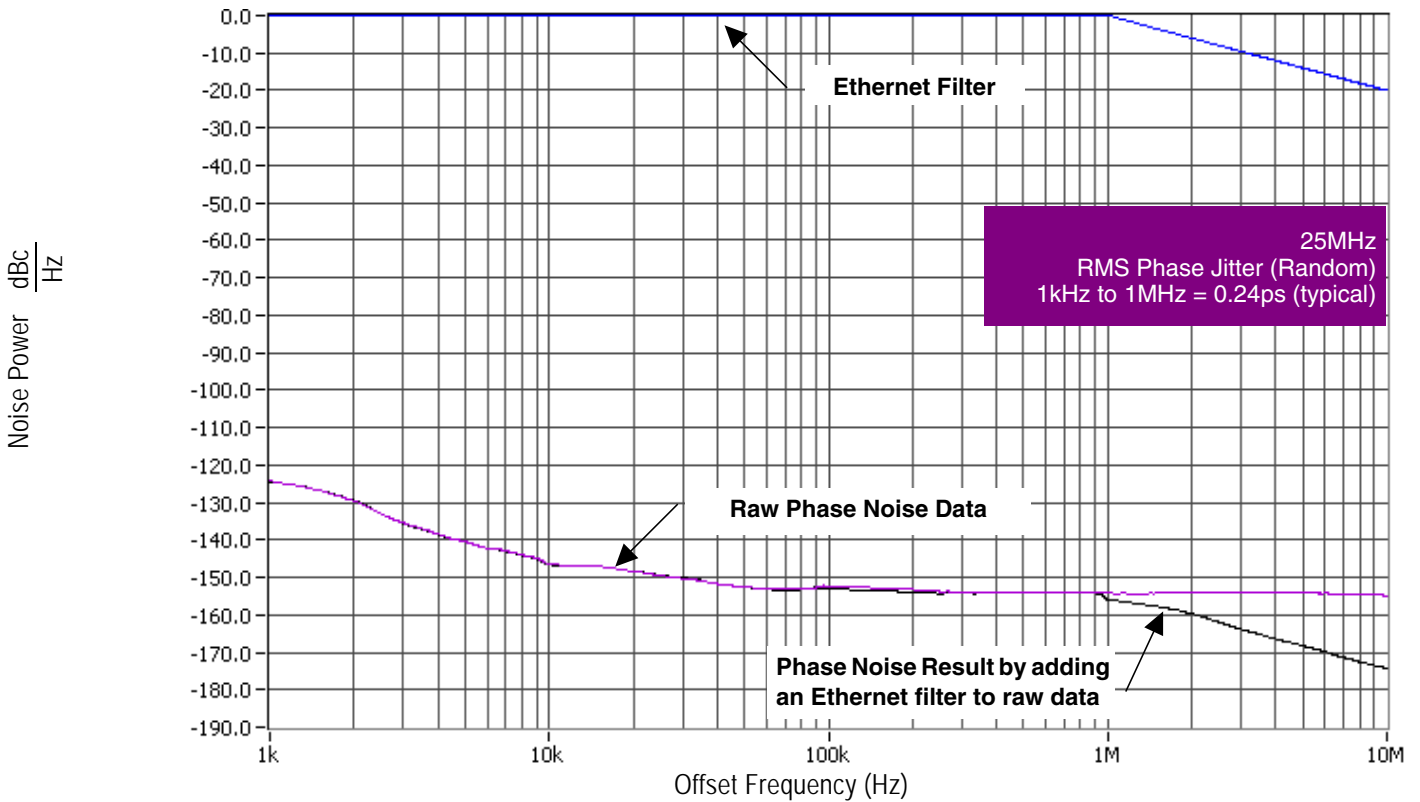

Parameter Measurement Information

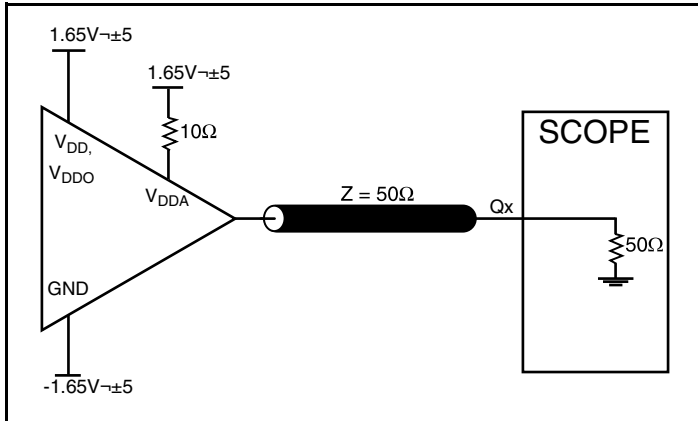

3.3V Core/3.3V LVCMOS Output Load AC Test Circuit

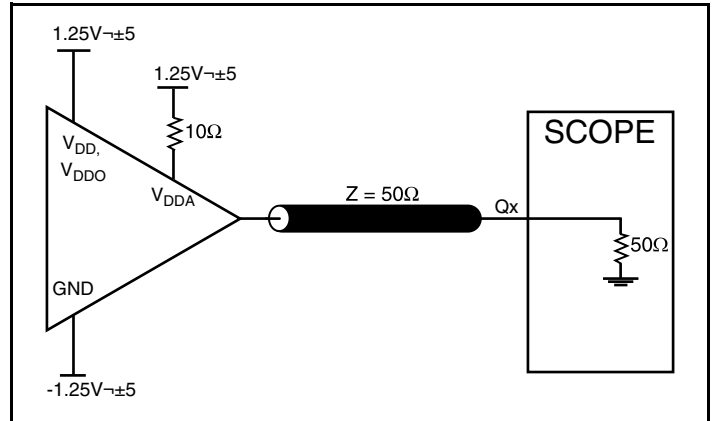

2.5V Core/2.5V LVCMOS Output Load AC Test Circuit

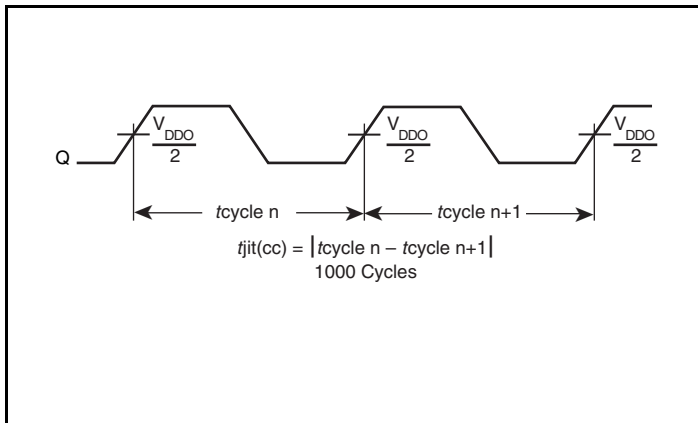

Cycle-to-Cycle Jitter

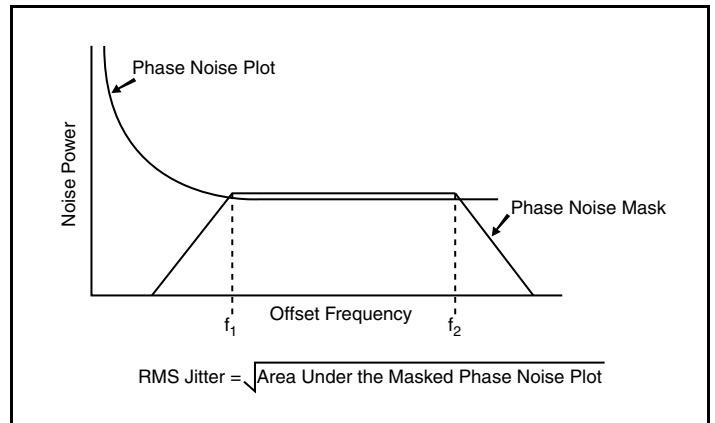

RMS Phase Jitter

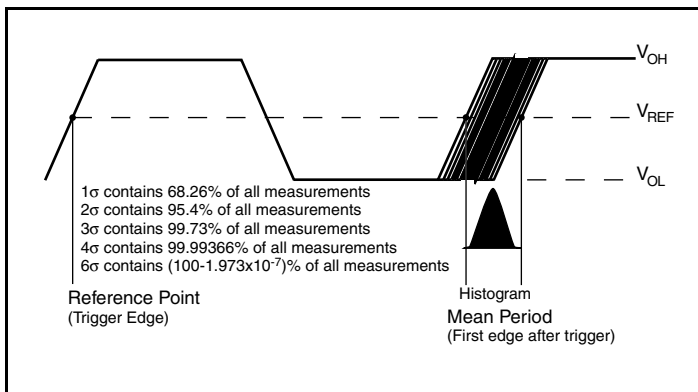

Period Jitter

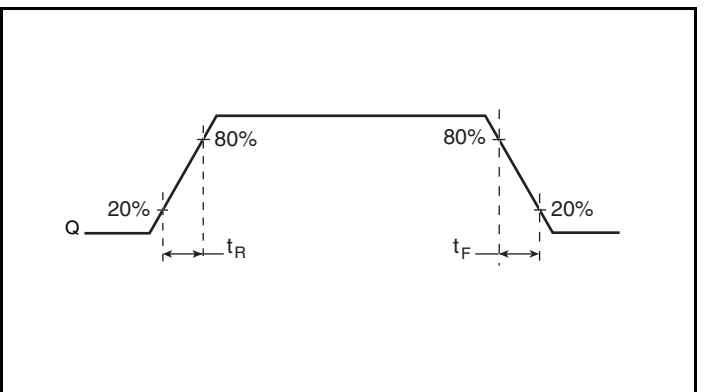

Output Rise/Fall Time

Parameter Measurement Information, continued

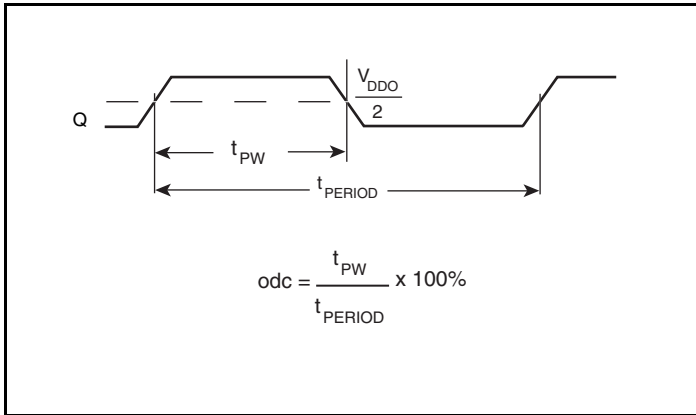

Output Duty Cycle/Pulse Width/Period

Application Information

Recommendations for Unused Input Pins

Inputs:

LVC MOS Control Pins

All control pins have internal pull-ups or pull-downs; additional resistance is not required but can be added for additional protection. A 1kΩ resistor can be used.

Schematic Example

Figure 1 shows an example of the 810251I application schematic. In this example, the device is operated either at $V_{DD} = 3.3V$ or $2.5V$. The decoupling capacitors should be located as close as possible to the power pin. The input is driven by an LVCMOS driver. An optional

3-pole filter can also be used for additional spur reduction. It is recommended that the loop filter components be laid out for the 3-pole option. This will also allow the 2-pole filter to be used.

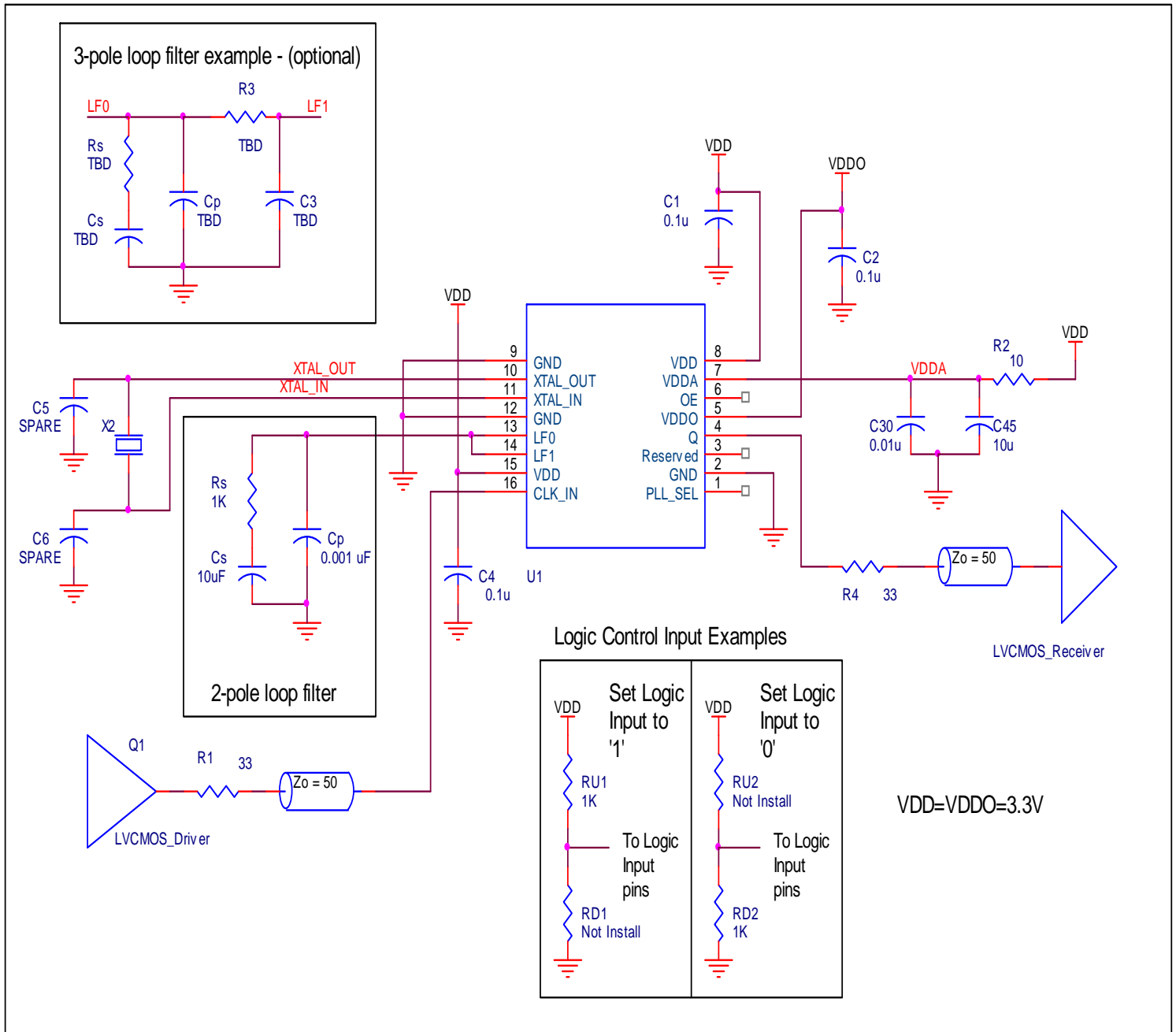

Figure 1. P.C. 810251I Schematic Example

VCXO-PLL EXTERNAL COMPONENTS

Choosing the correct external components and having a proper printed circuit board (PCB) layout is a key task for quality operation of the VCXO-PLL. In choosing a crystal, special precaution must be taken with the package and load capacitance (C_L). In addition, frequency, accuracy and temperature range must also be considered. Since the pulling range of a crystal also varies with the package, it is recommended that a metal-canned package like HC49 be used. Generally, a metal-canned package has a larger pulling range than a surface mounted device (SMD). For crystal selection information, refer to the *VCXO Crystal Selection Application Note*.

The crystal's load capacitance C_L characteristic determines its resonating frequency and is closely related to the VCXO tuning range. The total external capacitance seen by the crystal when installed on a board is the sum of the stray board capacitance, IC package lead capacitance, internal varactor capacitance and any installed tuning capacitors (C_{TUNE}).

If the crystal C_L is greater than the total external capacitance, the VCXO will oscillate at a higher frequency than the crystal specification. If the crystal C_L is lower than the total external capacitance, the VCXO will oscillate at a lower frequency than the crystal specification. In either case, the absolute tuning range is reduced. The correct value of C_L is dependant on the characteristics of the VCXO. The recommended C_L in the *Crystal Parameter Table* balances the tuning range by centering the tuning curve.

VCXO Characteristics Table

Symbol	Parameter	Typical	Units
k_{VCXO}	VCXO Gain	15000	Hz/V
C_{V_LOW}	Low Varactor Capacitance	9.8	pF
C_{V_HIGH}	High Varactor Capacitance	22.7	pF

VCXO-PLL Loop Bandwidth Selection Table

Bandwidth	Crystal Frequency (MHz)	R_S (k Ω)	C_S (μ F)	C_P (μ F)
246Hz (Low)	25	0.4	10	0.01
616Hz (Mid)	25	1.0	10	0.001
1000Hz (High)	25	1.65	10	0.001

Crystal Characteristics

Symbol	Parameter	Test Conditions	Minimum	Typical	Maximum	Units
	Mode of Oscillation		Fundamental			
f_N	Frequency			25		MHz
f_T	Frequency Tolerance				± 20	ppm
f_S	Frequency Stability				± 20	ppm
	Operating Temperature Range		-40		+85	$^{\circ}$ C
C_L	Load Capacitance			10		pF
C_O	Shunt Capacitance			4		pF
C_O / C_1	Pullability Ratio			220	240	
ESR	Equivalent Series Resistance				20	Ω
	Drive Level				1	mW
	Aging @ 25 $^{\circ}$ C				± 3 per year	ppm

The frequency of oscillation in the third overtone mode is not necessarily at exactly three times the fundamental frequency. The mechanical properties of the quartz element dictate the position of the overtones relative to the fundamental. The oscillator circuit may excite both the fundamental and overtone modes simultaneously. This will cause a nonlinearity in the tuning curve. This potential problem is why VCXO crystals are required to be tested for absence of any activity inside a ± 200 ppm window at three times the fundamental frequency. Refer to F_{L_3OVT} and $F_{L_3OVT_spurs}$ in the crystal Characteristics table.

The crystal and external loop filter components should be kept as close as possible to the device. Loop filter and crystal traces should be kept short and separated from each other. Other signal traces should be kept separate and not run underneath the device, loop filter or crystal components.

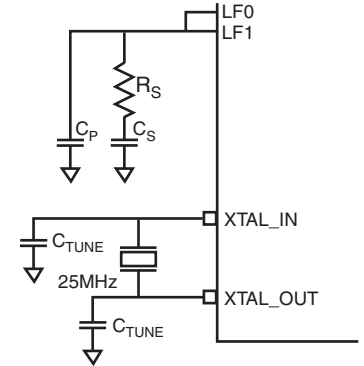

Power Considerations

This section provides information on power dissipation and junction temperature for the 8102511. Equations and example calculations are also provided.

1. Power Dissipation.

The total power dissipation for the 8102511 is the sum of the core power plus the analog power plus the power dissipated in the load(s). The following is the power dissipation for $V_{DD} = 3.3V + 5\% = 3.465V$, which gives worst case results.

- Power (core)_{MAX} = $V_{DD_MAX} * (I_{DD} + I_{DDA} + I_{DDO}) = 3.465V * (40mA + 7mA + 5mA) = \mathbf{180.18mW}$
- Output Impedance R_{OUT} Power Dissipation due to Loading 50Ω to $V_{DD}/2$
Output Current $I_{OUT} = V_{DD_MAX} / [2 * (50\Omega + R_{OUT})] = 3.465V / [2 * (50\Omega + 15\Omega)] = \mathbf{26.7mA}$
- Power Dissipation on the R_{OUT} per LVCMOS output
Power (R_{OUT}) = $R_{OUT} * (I_{OUT})^2 = 15\Omega * (26.7mA)^2 = \mathbf{10.7mW}$ per output

Dynamic Power Dissipation at 25MHz

$$\text{Power (25MHz)} = C_{PD} * \text{Frequency} * (V_{DD})^2 = 8pF * 25MHz * (3.465V)^2 = \mathbf{2.4mW}$$
 per output

Total Power Dissipation

- **Total Power**
= Power (core)_{MAX} + Power (R_{OUT}) + Power (25MHz)
= 180.18mW + 10.7mW + 2.4mW
= **193.28mW**

2. Junction Temperature.

Junction temperature, T_j , is the temperature at the junction of the bond wire and bond pad and it directly affects the reliability of the device. The maximum recommended junction temperature is 125°C. Limiting the internal transistor junction temperature, T_j , to 125°C ensures that the bond wire and bond pad temperature remains below 125°C.

The equation for T_j is as follows: $T_j = \theta_{JA} * Pd_{total} + T_A$

T_j = Junction Temperature

θ_{JA} = Junction-to-Ambient Thermal Resistance

Pd_{total} = Total Device Power Dissipation (example calculation is in section 1 above)

T_A = Ambient Temperature

In order to calculate junction temperature, the appropriate junction-to-ambient thermal resistance θ_{JA} must be used. Assuming no air flow and a multi-layer board, the appropriate value is 92.4°C/W per Table 5 below.

Therefore, T_j for an ambient temperature of 85°C with all outputs switching is:

$$85^\circ\text{C} + 0.193\text{W} * 92.4^\circ\text{C/W} = 102.8^\circ\text{C}.$$
 This is well below the limit of 125°C.

This calculation is only an example. T_j will obviously vary depending on the number of loaded outputs, supply voltage, air flow and the type of board (multi-layer).

Table 5. Thermal Resistance θ_{JA} for 16 Lead TSSOP, Forced Convection

Meters per Second	θ_{JA} by Velocity		
	0	1	2.5
Multi-Layer PCB, JEDEC Standard Test Boards	92.4°C/W	88.0°C/W	85.9°C/W

Reliability Information

Table 6. θ_{JA} vs. Air Flow Table for a 16 Lead TSSOP

θ_{JA} vs. Air Flow			
Meters per Second	0	1	2.5
Multi-Layer PCB, JEDEC Standard Test Boards	92.4°C/W	88.0°C/W	85.9°C/W

Transistor Count

The transistor count for 810251I: 937

Package Outline and Package Dimensions

Package Outline - G Suffix for 16 Lead TSSOP

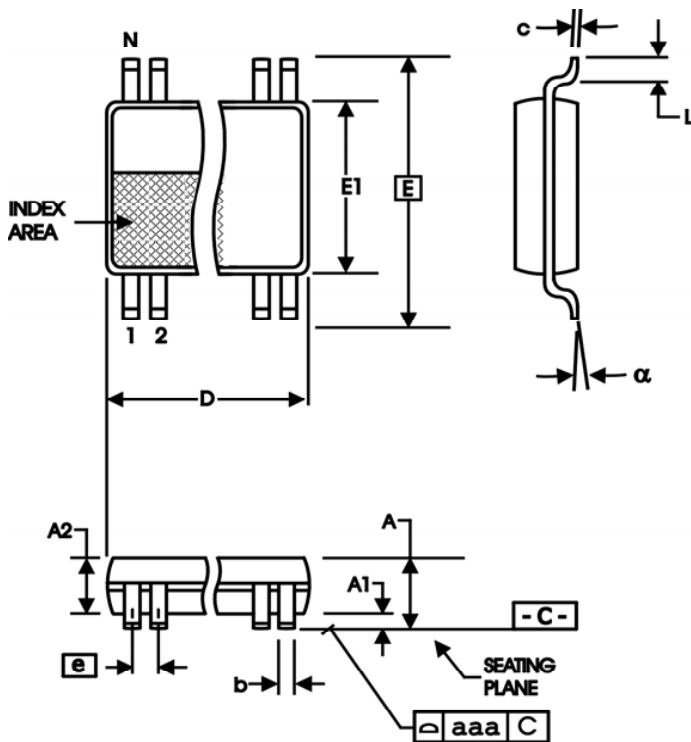

Table 7. Package Dimensions for 16 Lead TSSOP

All Dimensions in Millimeters		
Symbol	Minimum	Maximum
N	16	
A		1.20
A1	0.5	0.15
A2	0.80	1.05
b	0.19	0.30
c	0.09	0.20
D	4.90	5.10
E	6.40 Basic	
E1	4.30	4.50
e	0.65 Basic	
L	0.45	0.75
α	0°	8°
aaa		0.10

Reference Document: JEDEC Publication 95, MO-153

Ordering Information

Table 8. Ordering Information

Part/Order Number	Marking	Package	Shipping Packaging	Temperature
810251AGILF	10251AIL	16 Lead "Lead-Free" TSSOP	Tube	-40°C to 85°C
810251AGILFT	10251AIL	16 Lead "Lead-Free" TSSOP	Tape & Reel	-40°C to 85°C

Revision History Sheet

Rev	Table	Page	Description of Change	Date
A	T8	1	Updated Figure 1, Schematic layout.	7/28/09
		10	VCXO-PLL External Components section, reworded second from last paragraph "The frequency of oscillation in the third overtone mode....".	
		14	Changed marking from 810251AL to 10251AL. Changed datasheet header/footer format.	
B	T4A	1	Features List: deleted 'Absolute pull range is ± 50 ppm (using the internal oscillator)'	7/17/2012
	T4B	4	3.3V AC Characteristics Table - Added additional odc row with specs of 45min and 55max. Added Notes 3 & 4.	
		5	2.5V AC Characteristics Table - Added additional odc row with specs of 44min and 56max. Added Notes 3 & 4. HiPerClock references have been deleted throughout the datasheet.	
B	T4A	4	Added 'high' to Note 3.	10/5/2012
	T4B	5	Added 'high' to Note 3.	
	T8	13	Deleted quantity from Tape and Reel.	
B			Removed ICS from the part number where needed. Updated data sheet header and footer.	3/3/16

IMPORTANT NOTICE AND DISCLAIMER

RENESAS ELECTRONICS CORPORATION AND ITS SUBSIDIARIES (“RENESAS”) PROVIDES TECHNICAL SPECIFICATIONS AND RELIABILITY DATA (INCLUDING DATASHEETS), DESIGN RESOURCES (INCLUDING REFERENCE DESIGNS), APPLICATION OR OTHER DESIGN ADVICE, WEB TOOLS, SAFETY INFORMATION, AND OTHER RESOURCES “AS IS” AND WITH ALL FAULTS, AND DISCLAIMS ALL WARRANTIES, EXPRESS OR IMPLIED, INCLUDING, WITHOUT LIMITATION, ANY IMPLIED WARRANTIES OF MERCHANTABILITY, FITNESS FOR A PARTICULAR PURPOSE, OR NON-INFRINGEMENT OF THIRD-PARTY INTELLECTUAL PROPERTY RIGHTS.

These resources are intended for developers who are designing with Renesas products. You are solely responsible for (1) selecting the appropriate products for your application, (2) designing, validating, and testing your application, and (3) ensuring your application meets applicable standards, and any other safety, security, or other requirements. These resources are subject to change without notice. Renesas grants you permission to use these resources only to develop an application that uses Renesas products. Other reproduction or use of these resources is strictly prohibited. No license is granted to any other Renesas intellectual property or to any third-party intellectual property. Renesas disclaims responsibility for, and you will fully indemnify Renesas and its representatives against, any claims, damages, costs, losses, or liabilities arising from your use of these resources. Renesas' products are provided only subject to Renesas' Terms and Conditions of Sale or other applicable terms agreed to in writing. No use of any Renesas resources expands or otherwise alters any applicable warranties or warranty disclaimers for these products.

(Disclaimer Rev.1.01)

Corporate Headquarters

TOYOSU FORESIA, 3-2-24 Toyosu,
Koto-ku, Tokyo 135-0061, Japan
www.renesas.com

Trademarks

Renesas and the Renesas logo are trademarks of Renesas Electronics Corporation. All trademarks and registered trademarks are the property of their respective owners.

Contact Information

For further information on a product, technology, the most up-to-date version of a document, or your nearest sales office, please visit www.renesas.com/contact-us/.