

FEATURES:

- 0.5 MICRON CMOS Technology
- ESD > 2000V per MIL-STD-883, Method 3015; > 200V using machine model (C = 200pF, R = 0)
- V_{CC} = 3.3V ±0.3V, Normal Range
- V_{CC} = 2.7V to 3.6V, Extended Range
- CMOS power levels (0.4μW typ. static)
- Rail-to-Rail output swing for increased noise margin
- Available in QSOP and TSSOP packages

DESCRIPTION:

The FCT3245/A octal transceivers are built using advanced dual metal CMOS technology. These high-speed, low-power transceivers are ideal for asynchronous communication between two buses (A and B). The direction control pin (DIR) controls the direction of data flow. The output enable pin (\overline{OE}) overrides the direction control and disables both ports. All inputs are designed with hysteresis for improved noise margin.

The FCT3245/A has series current limiting resistors. These offer low ground bounce, minimal undershoot, and controlled output fall times—reducing the need for external series terminating resistors.

FUNCTIONAL BLOCK DIAGRAM

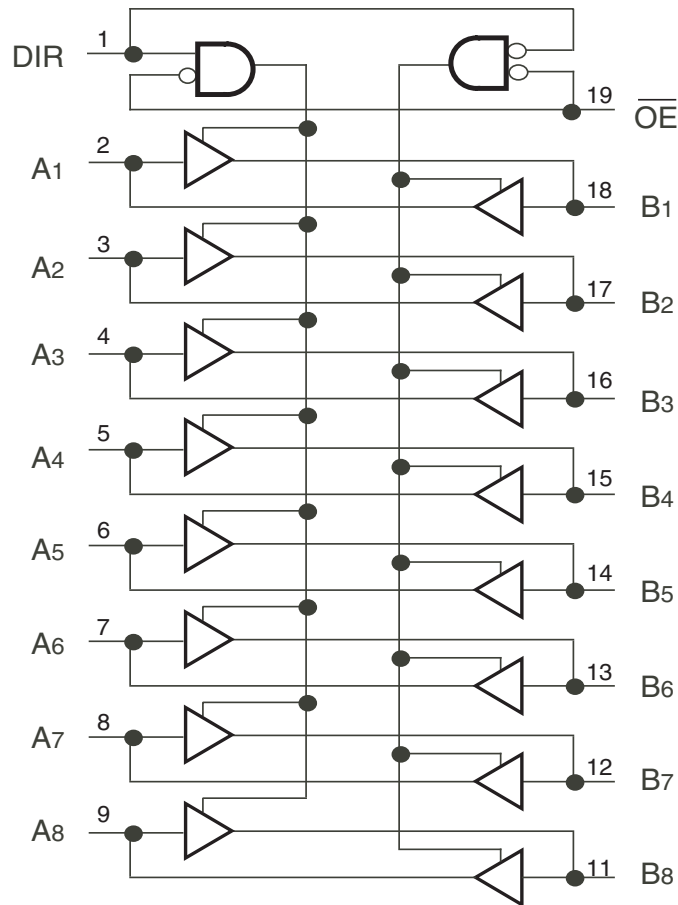

PIN CONFIGURATION

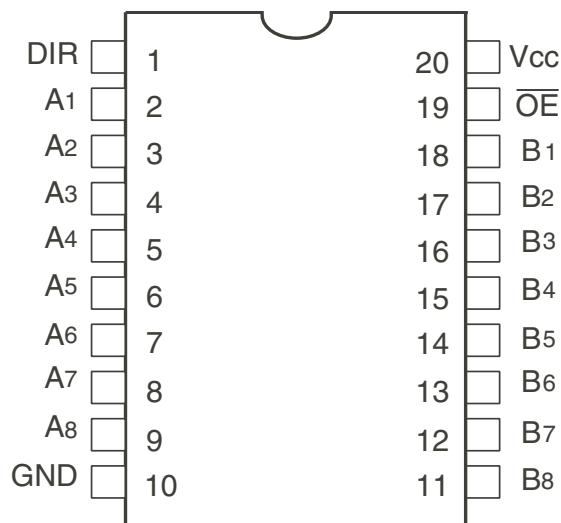

QSOP/TSSOP
TOP VIEW

ABSOLUTE MAXIMUM RATINGS⁽¹⁾

Symbol	Description	Max	Unit
V _{TERM} ⁽²⁾	Terminal Voltage with Respect to GND	-0.5 to +4.6	V
V _{TERM} ⁽³⁾	Terminal Voltage with Respect to GND	-0.5 to +7	V
V _{TERM} ⁽⁴⁾	Terminal Voltage with Respect to GND	-0.5 to V _{CC} +0.5	V
T _{STG}	Storage Temperature	-65 to +150	°C
I _{OUT}	DC Output Current	-60 to +60	mA

NOTES:

- Stresses greater than those listed under ABSOLUTE MAXIMUM RATINGS may cause permanent damage to the device. This is a stress rating only and functional operation of the device at these or any other conditions above those indicated in the operational sections of this specification is not implied. Exposure to absolute maximum rating conditions for extended periods may affect reliability.
- V_{CC} terminals.
- Input terminals.
- Outputs and I/O terminals.

CAPACITANCE (T_A = +25°C, F = 1.0MHz)

Symbol	Parameter ⁽¹⁾	Conditions	Typ.	Max.	Unit
C _{IN}	Input Capacitance	V _{IN} = 0V	3.5	6	pF
C _{OUT}	Output Capacitance	V _{OUT} = 0V	4	8	pF

NOTE:

- This parameter is measured at characterization but not tested.

PIN DESCRIPTION

Pin Names	Description
\overline{OE}	3-State Output Enable Inputs (Active LOW)
DIR	Direction Control Output
A x	Side A Inputs or 3-State Outputs
B x	Side B Inputs or 3-State Outputs

FUNCTION TABLE⁽¹⁾

Inputs		Outputs
\overline{OE}	DIR	
L	L	Bus B Data to Bus A
L	H	Bus A Data to Bus B
H	X	High Z State

NOTE:

- H = HIGH Voltage Level
X = Don't Care
L = LOW Voltage Level
Z = High Impedance

DC ELECTRICAL CHARACTERISTICS OVER OPERATING RANGE

Following Conditions Apply Unless Otherwise Specified:

Industrial: $T_A = -40^{\circ}\text{C}$ to $+85^{\circ}\text{C}$, $V_{CC} = 2.7\text{V}$ to 3.6V

Symbol	Parameter	Test Conditions ⁽¹⁾		Min.	Typ. ⁽²⁾	Max.	Unit	
V _{IH}	Input HIGH Level (Input pins)	Guaranteed Logic HIGH Level		2	—	5.5	V	
	Input HIGH Level (I/O pins)			2	—	V _{CC} +0.5		
V _{IL}	Input LOW Level (Input and I/O pins)	Guaranteed Logic LOW Level		-0.5	—	0.8	V	
I _{IH}	Input HIGH Current (Input pins)	V _{CC} = Max.	V _I = 5.5V	—	—	±1	μA	
	Input HIGH Current (I/O pins)		V _I = V _{CC}	—	—	±1		
I _{IL}	Input LOW Current (Input pins)		V _I = GND	—	—	±1		
	Input LOW Current (I/O pins)		V _I = GND	—	—	±1		
I _{OZH}	High Impedance Output Current (3-State Output pins)	V _{CC} = Max.	V _O = V _{CC}	—	—	±1	μA	
			V _O = GND	—	—	±1		
V _{IK}	Clamp Diode Voltage	V _{CC} = Min., I _{IH} = -18mA		—	-0.7	-1.2	V	
I _{ODH}	Output HIGH Current	V _{CC} = 3.3V, V _{IN} = V _{IH} or V _{IL} , V _O = 1.5V ⁽³⁾		-36	-60	-110	mA	
I _{ODL}	Output LOW Current	V _{CC} = 3.3V, V _{IN} = V _{IH} or V _{IL} , V _O = 1.5V ⁽³⁾		50	90	200	mA	
V _{OH}	Output HIGH Voltage	V _{CC} = Min.	I _{OH} = -0.1mA	V _{CC} -0.2	—	—	V	
		V _{IN} = V _{IH} or V _{IL}	I _{OH} = -3mA	2.4	3	—		
			V _{CC} = 3V	I _{OH} = -8mA	2.4 ⁽⁵⁾	3		—
V _{OL}	Output LOW Voltage	V _{CC} = Min.	I _{OL} = 0.1mA	—	—	0.2	V	
			V _{IN} = V _{IH} or V _{IL}	I _{OL} = 16mA	—	0.2		0.4
				I _{OL} = 24mA	—	0.3		0.55
		V _{CC} = 3V	I _{OL} = 24mA	—	0.3	0.5		
I _{OS}	Short Circuit Current ⁽⁴⁾	V _{CC} = Max., V _O = GND ⁽³⁾		-60	-135	-240	mA	
V _H	Input Hysteresis	—		—	150	—	mV	
I _{CC1} I _{CC2} I _{CC3}	Quiescent Power Supply Current	V _{CC} = Max., V _{IN} = GND or V _{CC}		—	0.1	10	μA	

NOTES:

1. For conditions shown as Min. or Max., use appropriate value specified under Electrical Characteristics for the applicable device type.
2. Typical values are at V_{CC} = 3.3V, +25°C ambient and maximum loading.
3. Not more than one output should be tested at one time. Duration of the test should not exceed one second.
4. This parameter is guaranteed but not tested.
5. V_{OH} = V_{CC} - 0.6V at rated current.

POWER SUPPLY CHARACTERISTICS

Symbol	Parameter	Test Conditions ⁽¹⁾		Min.	Typ. ⁽²⁾	Max.	Unit
I _{CC}	Quiescent Power Supply Current	V _{CC} = Max.	V _{IN} = V _{CC} - 0.6V	—	2	30	μA
I _{CCD}	Dynamic Power Supply Current ⁽⁴⁾	V _{CC} = Max. Outputs Open \overline{OE} = DIR = GND One Input Toggling 50% Duty Cycle	V _{IN} = V _{CC} V _{IN} = GND	—	60	85	μA/ MHz
I _C	Total Power Supply Current ⁽⁶⁾	V _{CC} = Max. Outputs Open f _i = 10MHz 50% Duty Cycle \overline{OE} = DIR = GND One Bit Toggling	V _{IN} = V _{CC} V _{IN} = GND	—	0.6	0.9	mA
			V _{IN} = V _{CC} - 0.6V V _{IN} = GND	—	0.6	0.9	
		V _{CC} = Max. Outputs Open f _i = 2.5MHz 50% Duty Cycle \overline{OE} = DIR = GND Eight Bits Toggling	V _{IN} = V _{CC} V _{IN} = GND	—	1.2	1.7 ⁽⁵⁾	
			V _{IN} = V _{CC} - 0.6V V _{IN} = GND	—	1.2	1.8 ⁽⁵⁾	

NOTES:

- For conditions shown as Min. or Max., use appropriate value specified under Electrical Characteristics for the applicable device type.
- Typical values are at V_{CC} = 3.3V, +25°C ambient.
- Per TTL driven input. All other inputs at V_{CC} or GND.
- This parameter is not directly testable, but is derived for use in Total Power Supply Calculations.
- Values for these conditions are examples of ΔI_{CC} formula. These limits are guaranteed but not tested.
- I_C = I_{QUIESCENT} + I_{INPUTS} + I_{DYNAMIC}
 $I_C = I_{CC} + \Delta I_{CC} D_H N_T + I_{CCD} (f_{CP} N_{CP} / 2 + f_i N_i)$
 I_{CC} = Quiescent Current (I_{CC}, I_{CCH}, and I_{CCZ})
 ΔI_{CC} = Power Supply Current for a TTL High Input
 D_H = Duty Cycle for TTL Inputs High
 N_T = Number of TTL Inputs at D_H
 I_{CCD} = Dynamic Current caused by an Input Transition Pair (HLH or LHL)
 f_{CP} = Clock Frequency for register devices (zero for non-register devices)
 N_{CP} = Number of clock inputs at f_{CP}
 f_i = Input Frequency
 N_i = Number of Inputs at f_i

SWITCHING CHARACTERISTICS OVER OPERATING RANGE⁽¹⁾

Symbol	Parameter	Condition ⁽²⁾	74FCT3245		74FCT3245A		Unit										
			Min. ⁽³⁾	Max.	Min. ⁽³⁾	Max.											
t _{PLH}	Propagation Delay	C _L = 50pF R _L = 500Ω	1.5	7	1.5	4.6	ns										
t _{PHL}	A to B, B to A																
t _{PZH}	Output Enable Time							1.5	9.5	1.5	6.2	ns					
t _{PZL}	\overline{OE} to A or B																
t _{PHZ}	Output Disable Time												1.5	7.5	1.5	5	ns
t _{PLZ}	\overline{OE} to A or B																
t _{PZH}	Output Enable Time	1.5	9.5	1.5	6.2	ns											
t _{PZL}	DIR to A or B ⁽⁴⁾																
t _{PHZ}	Output Disable Time						1.5	7.5	1.5	5	ns						
t _{PLZ}	DIR to A or B ⁽⁴⁾																

NOTES:

- Propagation Delays and Enable/Disable times are with V_{CC} = 3.3V ±0.3V, Normal Range. For V_{CC} = 2.7V to 3.6V, Extended Range, all Propagation Delays and Enable/Disable times should be degraded by 20%.
- See test circuit and waveforms.
- Minimum limits are guaranteed but not tested on Propagation Delays.
- This parameter is guaranteed but not tested.

TEST CIRCUITS AND WAVEFORMS

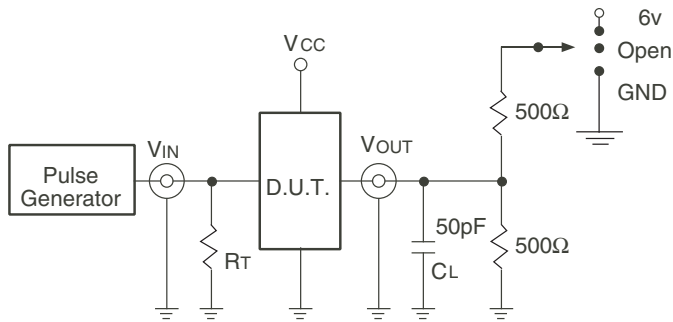

Test Circuits for All Outputs

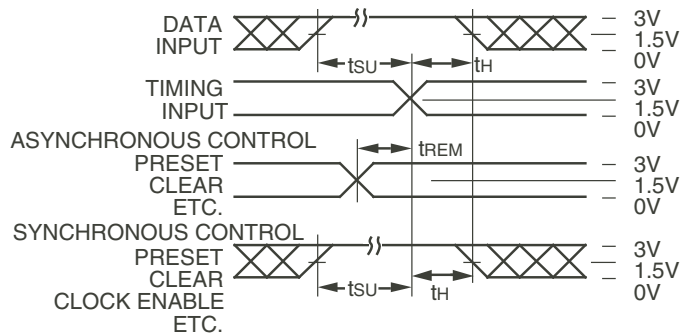

Set-Up, Hold, and Release Times

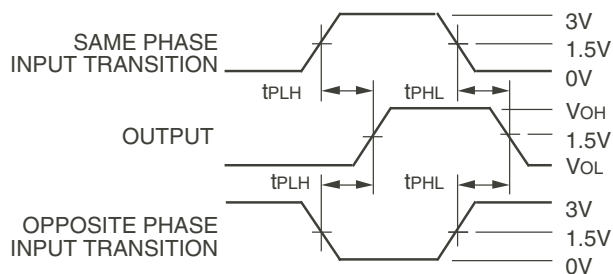

Propagation Delay

SWITCH POSITION

Test	Switch
Open Drain Disable Low Enable Low	6V
Disable High Enable High	GND
All Other Tests	Open

DEFINITIONS:

CL = Load capacitance: includes jig and probe capacitance.
RT = Termination resistance: should be equal to ZOUT of the Pulse Generator.

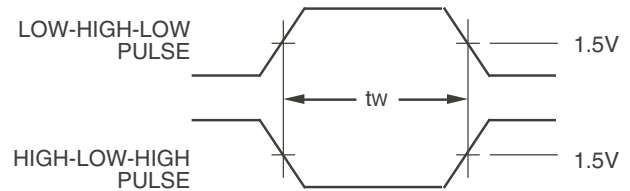

Pulse Width

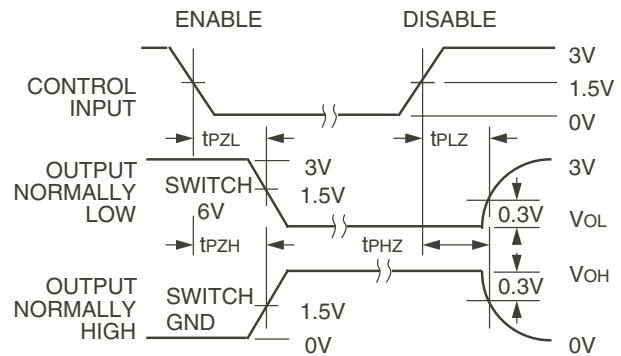

Enable and Disable Times

NOTES:

1. Diagram shown for input Control Enable-LOW and input Control Disable-HIGH.
2. Pulse Generator for All Pulses: Rate $\leq 1.0\text{MHz}$; $Z_o \leq 50\Omega$; $t_r \leq 2.5\text{ns}$; $t_f \leq 2.5\text{ns}$.
3. If Vcc is below 3V, input voltage swings should be adjusted not to exceed Vcc.

ORDERING INFORMATION

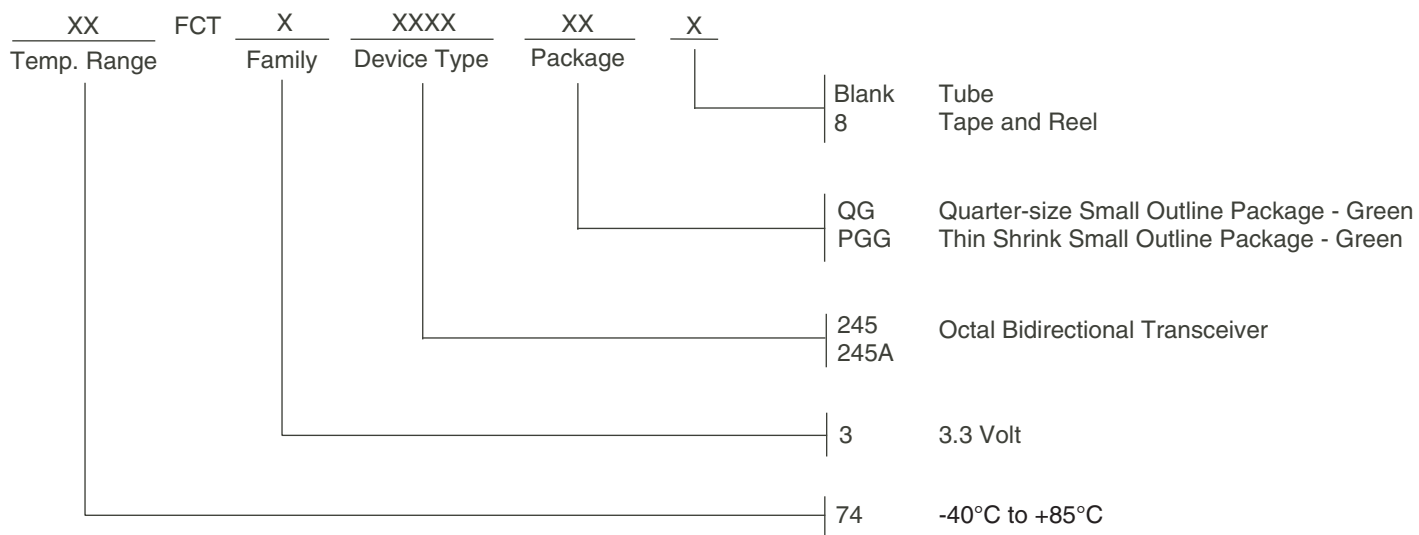

Datasheet Document History

10/03/2009	Pg. 6	Updated the ordering information by removing the "IDT" notation and non RoHS part.
05/10/2018	Pg. 6	Updated the ordering information by adding Tape and Reel.

IMPORTANT NOTICE AND DISCLAIMER

RENESAS ELECTRONICS CORPORATION AND ITS SUBSIDIARIES (“RENESAS”) PROVIDES TECHNICAL SPECIFICATIONS AND RELIABILITY DATA (INCLUDING DATASHEETS), DESIGN RESOURCES (INCLUDING REFERENCE DESIGNS), APPLICATION OR OTHER DESIGN ADVICE, WEB TOOLS, SAFETY INFORMATION, AND OTHER RESOURCES “AS IS” AND WITH ALL FAULTS, AND DISCLAIMS ALL WARRANTIES, EXPRESS OR IMPLIED, INCLUDING, WITHOUT LIMITATION, ANY IMPLIED WARRANTIES OF MERCHANTABILITY, FITNESS FOR A PARTICULAR PURPOSE, OR NON-INFRINGEMENT OF THIRD PARTY INTELLECTUAL PROPERTY RIGHTS.

These resources are intended for developers skilled in the art designing with Renesas products. You are solely responsible for (1) selecting the appropriate products for your application, (2) designing, validating, and testing your application, and (3) ensuring your application meets applicable standards, and any other safety, security, or other requirements. These resources are subject to change without notice. Renesas grants you permission to use these resources only for development of an application that uses Renesas products. Other reproduction or use of these resources is strictly prohibited. No license is granted to any other Renesas intellectual property or to any third party intellectual property. Renesas disclaims responsibility for, and you will fully indemnify Renesas and its representatives against, any claims, damages, costs, losses, or liabilities arising out of your use of these resources. Renesas' products are provided only subject to Renesas' Terms and Conditions of Sale or other applicable terms agreed to in writing. No use of any Renesas resources expands or otherwise alters any applicable warranties or warranty disclaimers for these products.

(Rev.1.0 Mar 2020)

Corporate Headquarters

TOYOSU FORESIA, 3-2-24 Toyosu,
Koto-ku, Tokyo 135-0061, Japan
www.renesas.com

Contact Information

For further information on a product, technology, the most up-to-date version of a document, or your nearest sales office, please visit:
www.renesas.com/contact/

Trademarks

Renesas and the Renesas logo are trademarks of Renesas Electronics Corporation. All trademarks and registered trademarks are the property of their respective owners.