

## Description

The ICS621 is a low skew, single input to four output, clock buffer. The device operates from a single 1.2 to 1.8 volt supply and has a 3.3 volt tolerant input, making it ideal for level translation.

IDT makes many non-PLL and PLL based low skew output devices as well as Zero Delay Buffers to synchronize clocks. Contact us for all of your clocking needs.

## Features

- Low skew outputs (150 ps)
- Packaged in 8-pin SOIC or 8-pin DFN (2x2mm)
- RoHS 5 or RoHS 6 (lead-free) package
- Low power CMOS technology
- Operating voltages of 1.2 V to 1.8 V
- Output Enable pin tri-states outputs
- 3.3 V tolerant input clock
- Industrial or commercial temperature ranges

## Block Diagram

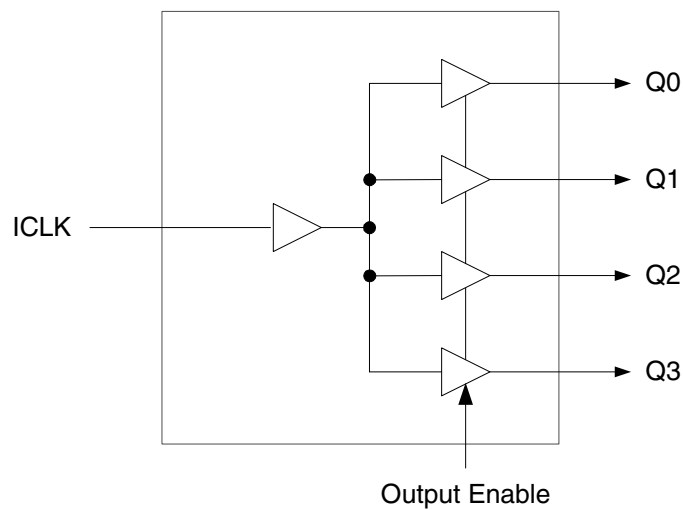

## Pin Assignment (8-pin SOIC)

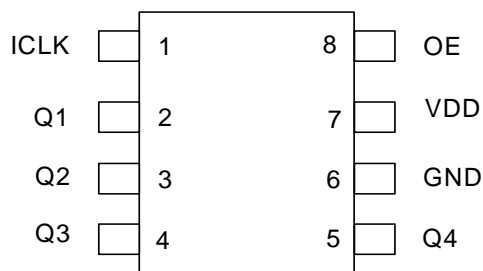

## Pin Assignment (8-pin DFN)

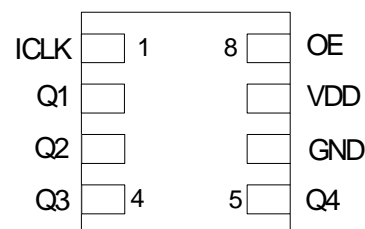

## Pin Descriptions

Pin Number	Pin Name	Pin Type	Pin Description
1	ICLK	Input	Clock Input. 3.3 V tolerant input.
2	Q1	Output	Clock Output 1.
3	Q2	Output	Clock Output 2.
4	Q3	Output	Clock Output 3.
5	Q4	Output	Clock Output 4.
6	GND	Power	Connect to ground.
7	VDD	Power	Connect to +1.2 V or +1.8 V.
8	OE	Input	Output Enable. Tri-states outputs when low. Connect to VDD for normal operation.

## External Components

A minimum number of external components are required for proper operation. A decoupling capacitor of 0.01  $\mu\text{F}$  should be connected between VDD on pin 7 and GND on pin 6, as close to the device as possible. A 33  $\Omega$  series terminating resistor may be used on each clock output if the trace is longer than 1 inch.

To achieve the low output skew that the ICS621 is capable of, careful attention must be paid to board layout. Essentially, all four outputs must have identical terminations, identical loads and identical trace geometries. If they do not, the output skew will be degraded. For example, using a 30 $\Omega$  series termination on one output (with 33 $\Omega$  on the others) will cause at least 15 ps of skew.

## Absolute Maximum Ratings

Stresses above the ratings listed below can cause permanent damage to the ICS621. These ratings, which are standard values for IDT commercially rated parts, are stress ratings only. Functional operation of the device at these or any other conditions above those indicated in the operational sections of the specifications is not implied. Exposure to absolute maximum rating conditions for extended periods can affect product reliability. Electrical parameters are guaranteed only over the recommended operating temperature range.

Item	Rating
Supply Voltage, VDD	5 V
Output Enable and All Outputs	-0.5 V to VDD+0.5 V
ICLK	-0.5 V to 3.6 V (VDD > 0V)
Ambient Operating Temperature (industrial)	-40 to +85 °C
Ambient Operating Temperature (commercial)	0 to +70 °C
Storage Temperature	-65 to +150° C
Junction Temperature	125° C
Soldering Temperature	260° C

## Recommended Operation Conditions

Parameter	Min.	Typ.	Max.	Units
Ambient Operating Temperature (industrial)	-40		+85	°C
Ambient Operating Temperature (commercial)	0		+70	°C
Power Supply Voltage (measured in respect to GND)	1.14		1.89	V

## DC Electrical Characteristics

VDD=1.2 V ±5%, Ambient temperature -40 to +85° C or 0 to +70° C, unless stated otherwise

Parameter	Symbol	Conditions	Min.	Typ.	Max.	Units
Operating Voltage	VDD		1.14		1.26	V
Input High Voltage	V <sub>IH</sub>	Note 1, ICLK, OE	0.65VDD		3.6	V
Input Low Voltage	V <sub>IL</sub>	Note 1, ICLK, OE			0.35VDD	V
Output High Voltage	V <sub>OH</sub>	I <sub>OH</sub> = -2 mA	0.75VDD			V
Output Low Voltage	V <sub>OL</sub>	I <sub>OL</sub> = 2 mA			0.25VDD	V
Operating Supply Current	IDD	No load, 133 MHz		TBD		mA
Nominal Output Impedance	Z <sub>O</sub>			20		Ω
Input Capacitance	C <sub>IN</sub>	ICLK, OE pin		5		pF
Short Circuit Current	I <sub>OS</sub>			±20		mA

Notes: 1. Nominal switching threshold is VDD/2

VDD=1.5 V ±5%, Ambient temperature -40 to +85° C or 0 to +70° C, unless stated otherwise

Parameter	Symbol	Conditions	Min.	Typ.	Max.	Units
Operating Voltage	VDD		1.425		1.575	V
Input High Voltage	V <sub>IH</sub>	Note 1, ICLK, OE	0.65VDD		3.6	V
Input Low Voltage	V <sub>IL</sub>	Note 1, ICLK, OE			0.35VDD	V
Output High Voltage	V <sub>OH</sub>	I <sub>OH</sub> = -6 mA	0.75VDD			V
Output Low Voltage	V <sub>OL</sub>	I <sub>OL</sub> = 6 mA			0.25VDD	V
Operating Supply Current	IDD	No load, 133 MHz		25		mA
Nominal Output Impedance	Z <sub>O</sub>			20		Ω
Input Capacitance	C <sub>IN</sub>	ICLK, OE pin		5		pF
Short Circuit Current	I <sub>OS</sub>			±28		mA

Notes: 1. Nominal switching threshold is VDD/2

VDD=1.8 V ±5%, Ambient temperature -40 to +85° C or 0 to +70° C, unless stated otherwise

Parameter	Symbol	Conditions	Min.	Typ.	Max.	Units
Operating Voltage	VDD		1.71		1.89	V
Input High Voltage, ICLK	V <sub>IH</sub>	Note 1, ICLK, OE	0.65VDD		3.6	V
Input Low Voltage, ICLK	V <sub>IL</sub>	Note 1, ICLK, OE			0.35VDD	V
Output High Voltage	V <sub>OH</sub>	I <sub>OH</sub> = -8 mA	1.35			V
Output Low Voltage	V <sub>OL</sub>	I <sub>OL</sub> = 8 mA			0.45	V
Operating Supply Current	IDD	No load, 133 MHz		50		mA
Nominal Output Impedance	Z <sub>O</sub>			20		Ω
Input Capacitance	C <sub>IN</sub>	ICLK, OE pin		5		pF
Short Circuit Current	I <sub>OS</sub>			±50		mA

Notes: 1. Nominal switching threshold is VDD/2

## AC Electrical Characteristics

VDD = 1.2 V ±5%, Ambient Temperature -40 to +85°C or 0 to +70°C, unless stated otherwise

Parameter	Symbol	Conditions	Min.	Typ.	Max.	Units
Input Frequency			0		100	MHz
Output Rise Time	t <sub>OR</sub>	20% to 80%, Note 3		1.0	1.5	ns
Output Fall Time	t <sub>OF</sub>	80% to 20%, Note 3		1.0	1.5	ns
Propagation Delay	Note 1		2.2	3	5	ns
Output to Output Skew	Note 2	Rising edges at VDD/2		0	±150	ps

VDD = 1.5 V ±5%, Ambient Temperature -40 to +85°C or 0 to +70°C, unless stated otherwise

Parameter	Symbol	Conditions	Min.	Typ.	Max.	Units
Input Frequency			0		166	MHz
Output Rise Time	t <sub>OR</sub>	20% to 80%, Note 3		1.0	1.5	ns
Output Fall Time	t <sub>OF</sub>	80% to 20%, Note 3		1.0	1.5	ns
Propagation Delay	Note 1		2.2	3	5	ns
Output to Output Skew	Note 2	Rising edges at VDD/2		0	±150	ps

VDD = 1.8 V ±5%, Ambient Temperature -40 to +85°C or 0 to +70°C, unless stated otherwise

Parameter	Symbol	Conditions	Min.	Typ.	Max.	Units
Input Frequency			0		200	MHz
Output Rise Time	t <sub>OR</sub>	20% to 80%, Note 3		1.0	1.5	ns
Output Fall Time	t <sub>OF</sub>	80% to 20%, Note 3		1.0	1.5	ns
Propagation Delay	Note 1		2.2	3	5	ns
Output to Output Skew	Note 2	Rising edges at VDD/2		0	±150	ps

- Notes: 1. With rail to rail input clock  
 2. Between any 2 outputs with equal loading.  
 3. Measured with a 15 pF load.

## Thermal Characteristics

Parameter	Symbol	Conditions	Min.	Typ.	Max.	Units
Thermal Resistance Junction to Ambient	θ <sub>JA</sub>	Still air		150		°C/W
	θ <sub>JA</sub>	1 m/s air flow		140		°C/W
	θ <sub>JA</sub>	3 m/s air flow		120		°C/W
Thermal Resistance Junction to Case	θ <sub>JC</sub>			40		°C/W
Case Temperature					120	°C
Thermal Resistance Junction to Top of Case	Ψ <sub>JT</sub>	Still air		20		°C/W

### Package Outline and Package Dimensions (8-pin DFN 2x2mm, 0.5mm pitch)

Package dimensions are kept current with JEDEC Publication No. 95,

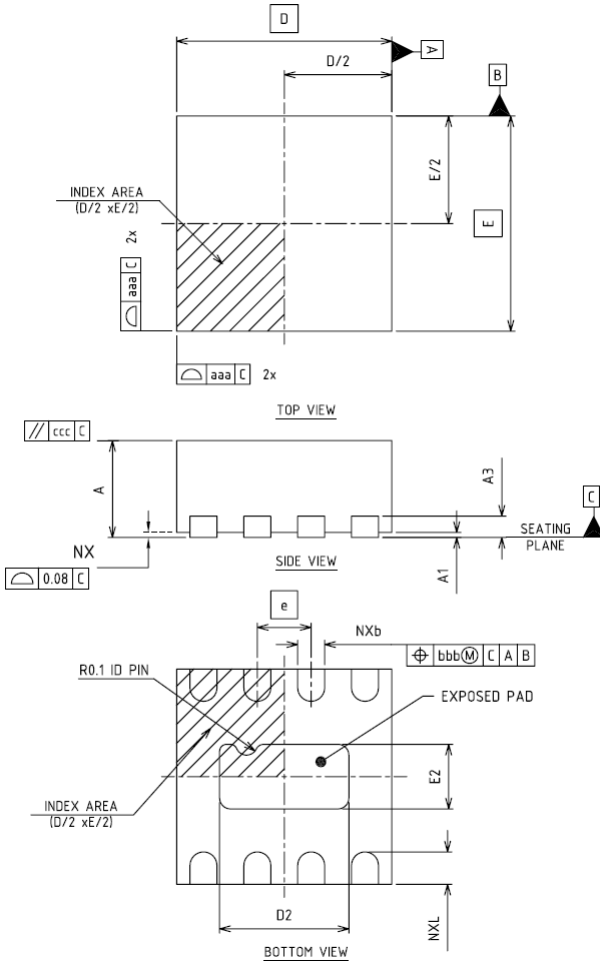

Symbol	Millimeters	
	Min	Max
A	0.80	1.00
A1	0	0.05
A3	0.20 Reference	
b	0.20	0.30
N	8	
N <sub>D</sub>	4	
N <sub>E</sub>	0	
D	2.00 BASIC	
E	2.00 BASIC	
e	0.50 BASIC	
D2	1.05	1.25
E2	0.45	0.65
L	0.20	0.40
aaa	0.15	
bbb	0.10	
ccc	0.10	

### Package Outline and Package Dimensions (8-pin SOIC, 150 Mil. Narrow Body)

Package dimensions are kept current with JEDEC Publication No. 95

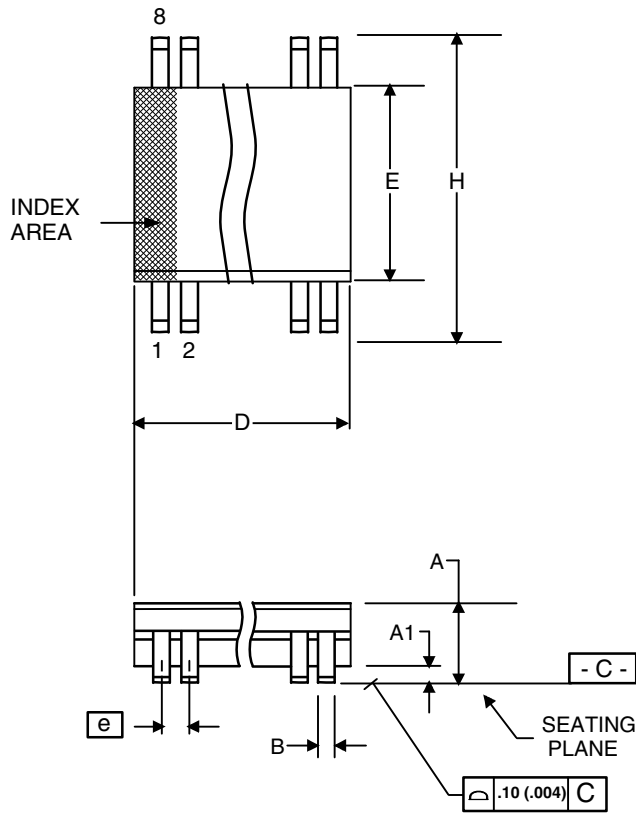

Symbol	Millimeters		Inches*	
	Min	Max	Min	Max
A	1.35	1.75	.0532	.0688
A1	0.10	0.25	.0040	.0098
B	0.33	0.51	.013	.020
C	0.19	0.25	.0075	.0098
D	4.80	5.00	.1890	.1968
E	3.80	4.00	.1497	.1574
e	1.27 BASIC		0.050 BASIC	
H	5.80	6.20	.2284	.2440
h	0.25	0.50	.010	.020
L	0.40	1.27	.016	.050
α	0°	8°	0°	8°

\*For reference only. Controlling dimensions in mm.

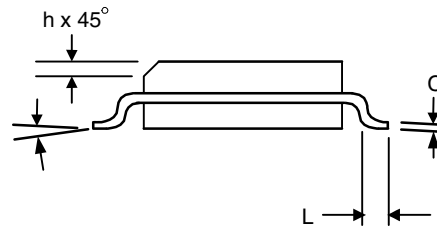

## Ordering Information

Part / Order Number	Marking	Shipping Packaging	Package	Temperature
621MILF	621MILF	Tubes	8-pin SOIC	-40 to +85° C
621MILFT	621MILF	Tape and Reel	8-pin SOIC	-40 to +85° C
621MLF	621MLF	Tubes	8-pin SOIC	0 to +70° C
621MLFT	621MLF	Tape and Reel	8-pin SOIC	0 to +70° C
621NLFT	1NL	Tape and Reel	8-pin DFN	0 to +70° C
621NILFT	1IL	Tape and Reel	8-pin DFN	-40 to +85° C

**“LF” suffix to the part number are the Pb-Free configuration and are RoHS compliant.**

While the information presented herein has been checked for both accuracy and reliability, Integrated Device Technology (IDT) result from its use. No other circuits, patents, or licenses are implied. This product is intended for use in normal commercial applications. Any other applications such as those requiring extended temperature range, high reliability, or other extraordinary environmental requirements are not recommended without additional processing by IDT. IDT reserves the right to change any circuitry or specifications without notice. IDT does not authorize or warrant any IDT product for use in life support devices or critical medical instruments.



## Revision History

Rev.	Originator	Date	Description of Change
A	S. Sharma	06/08/06	New device/datasheet; Preliminary release.
B	S. Sharma	03/09/07	Removed Tape and Reel part number from DFN package ordering info.
C		05/27/08	Removed "Preliminary" and updated part ordering info.
D	R.Willner	08/01/08	Correct VIH values to reflect 3.3 V tolerant clock input
E		10/27/09	Added EOL note for non-green parts
F		05/13/10	Removed EOL note and non-green parts
G	K.B.	05/13/10	Corrected DFN topmark.

ICS621

LOW SKEW 1 TO 4 CLOCK BUFFER

FAN OUT BUFFER

## IMPORTANT NOTICE AND DISCLAIMER

RENESAS ELECTRONICS CORPORATION AND ITS SUBSIDIARIES (“RENESAS”) PROVIDES TECHNICAL SPECIFICATIONS AND RELIABILITY DATA (INCLUDING DATASHEETS), DESIGN RESOURCES (INCLUDING REFERENCE DESIGNS), APPLICATION OR OTHER DESIGN ADVICE, WEB TOOLS, SAFETY INFORMATION, AND OTHER RESOURCES “AS IS” AND WITH ALL FAULTS, AND DISCLAIMS ALL WARRANTIES, EXPRESS OR IMPLIED, INCLUDING, WITHOUT LIMITATION, ANY IMPLIED WARRANTIES OF MERCHANTABILITY, FITNESS FOR A PARTICULAR PURPOSE, OR NON-INFRINGEMENT OF THIRD PARTY INTELLECTUAL PROPERTY RIGHTS.

These resources are intended for developers skilled in the art designing with Renesas products. You are solely responsible for (1) selecting the appropriate products for your application, (2) designing, validating, and testing your application, and (3) ensuring your application meets applicable standards, and any other safety, security, or other requirements. These resources are subject to change without notice. Renesas grants you permission to use these resources only for development of an application that uses Renesas products. Other reproduction or use of these resources is strictly prohibited. No license is granted to any other Renesas intellectual property or to any third party intellectual property. Renesas disclaims responsibility for, and you will fully indemnify Renesas and its representatives against, any claims, damages, costs, losses, or liabilities arising out of your use of these resources. Renesas' products are provided only subject to Renesas' Terms and Conditions of Sale or other applicable terms agreed to in writing. No use of any Renesas resources expands or otherwise alters any applicable warranties or warranty disclaimers for these products.

(Rev.1.0 Mar 2020)

### Corporate Headquarters

TOYOSU FORESIA, 3-2-24 Toyosu,  
Koto-ku, Tokyo 135-0061, Japan  
[www.renesas.com](http://www.renesas.com)

### Contact Information

For further information on a product, technology, the most up-to-date version of a document, or your nearest sales office, please visit:  
[www.renesas.com/contact/](http://www.renesas.com/contact/)

### Trademarks

Renesas and the Renesas logo are trademarks of Renesas Electronics Corporation. All trademarks and registered trademarks are the property of their respective owners.