

FEATURES:

- Advanced, low power CMOS process
- 5V tolerant inputs
- Low skew outputs (<250ps)
- Input/Output frequency up to 160MHz
- Non-inverting output clock
- Ideal for networking clocks
- Operating voltage of 3V
- Output enable mode tri-states outputs
- Lead-free packaging available
- Available in SOIC package

DESCRIPTION:

The 5V551 clock driver is built using advanced CMOS technology. This low skew clock driver offers 1:4 fanout. The fanout from a single input reduces loading on the preceding driver and provides an efficient clock distribution network. The 5V551 offers low capacitance inputs. Typical applications are clock and signal distribution.

FUNCTIONAL BLOCK DIAGRAM

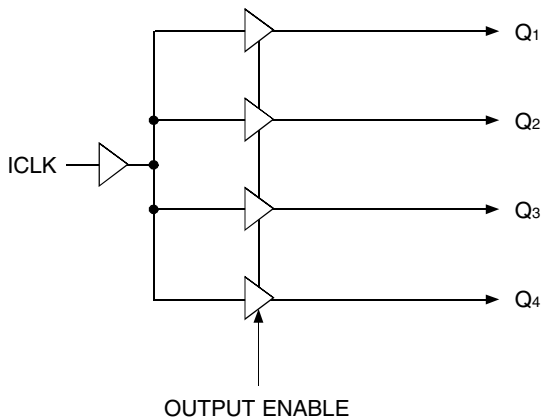

PIN CONFIGURATION

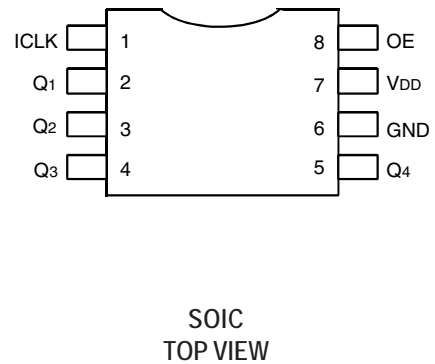

ABSOLUTE MAXIMUM RATINGS⁽¹⁾

Symbol	Description	Max.	Unit
V _{DD}	Supply Voltage	-0.5 to +4.6	V
V _{TERM}	All Inputs	-0.5 to +7	V
	All Outputs	-0.5 to V _{DD} + 0.5	
T _A	Ambient Operating Temp	-40 to +85	°C
T _{STG}	Storage Temperature	-65 to +150	°C
T _J	Junction Temperature	150	°C
T _{SOLDER}	Soldering Temperature	260	°C

NOTE:

- Stresses greater than those listed under ABSOLUTE MAXIMUM RATINGS may cause permanent damage to the device. This is a stress rating only and functional operation of the device at these or any other conditions above those indicated in the operational sections of this specification is not implied. Exposure to absolute maximum rating conditions for extended periods may affect reliability.

PIN DESCRIPTION

Name	Type	Description
ICLK	Input	Clock Input, internal pull-up resistor
Q _n	Output	Clock Outputs
GND	PWR	Connect to Ground
V _{DD}	PWR	Connect to 3.3V
OE	Input	Output Enable. Tri-states outputs when LOW. Internal pull-up resistor.

EXTERNAL COMPONENTS

A minimum number of external components are required for proper operation. A decoupling capacitor of 0.01µF should be connected between V_{DD} on pin 7 and GND on pin 6, as close to the device as possible. A 33Ω series terminating resistor may be used on each clock output if the trace is longer than one inch.

RECOMMENDED OPERATING RANGE

Symbol	Description	Min.	Typ.	Max.	Unit
T _A	Ambient Operating Temperature	-40	—	+85	°C
V _{DD}	Power Supply Voltage (measured in respect to GND)	3	—	3.6	V

DC ELECTRICAL CHARACTERISTICS OVER OPERATING RANGE

Following Conditions Apply Unless Otherwise Specified

T_A = -40°C to +85°C, V_{DD} = 3.3V ± 5%

Symbol	Parameter	Test Conditions	Min.	Typ.	Max.	Unit
V _{DD}	Operating Voltage		3.15	—	3.45	V
V _{IH}	Input HIGH Voltage, ICLK ⁽¹⁾		V _{DD} /2 + 0.7	—	—	V
V _{IL}	Input LOW Voltage, ICLK ⁽¹⁾		—	—	V _{DD} /2 - 0.7	V
V _{IH}	Input HIGH Voltage, OE		2	—	—	V
V _{IL}	Input LOW Voltage, OE		—	—	0.8	V
V _{OH}	Output HIGH Voltage	I _{OH} = -25mA	2.4	—	—	V
V _{OL}	Output LOW Voltage	I _{OL} = 25mA	—	—	0.4	V
V _{OH}	Output HIGH Voltage (CMOS)	I _{OH} = -12mA	V _{DD} - 0.4	—	—	V
I _{DD}	Operating Supply Current	No Load, 135MHz	—	18	—	mA
Z _o	Nominal Output Impedance		—	20	—	Ω
R _{PU}	Internal Pull-Up Resistor	ICLK, OE _x = 0V	—	350	—	kΩ
C _{IN}	Input Capacitance	OE Pin	—	5	—	pF
		ICLK	—	3	—	
I _{OS}	Short Circuit Current		—	±90	—	mA

NOTE:

- Nominal switching threshold is V_{DD}/2.

AC ELECTRICAL CHARACTERISTICS OVER OPERATING RANGE

Following Conditions Apply Unless Otherwise Specified

$T_A = -40^\circ\text{C}$ to $+85^\circ\text{C}$, $V_{DD} = 3.3\text{V} \pm 5\%$

Symbol	Parameter	Test Conditions	Min.	Typ.	Max.	Unit
F_{IN}	Input Frequency		0	—	160	MHz
F_{OUT}	Output Frequency ⁽¹⁾	15pF load	—	—	160	MHz
t_{OR}	Output Clock Rise Time	0.8V to 2V	—	—	1.5	ns
t_{OF}	Output Clock Fall Time	2V to 0.8V	—	—	1.5	ns
t_{PD}	Propagation Delay ⁽²⁾	135MHz	2	4	8	ns
$t_{sk(o)}$	Output to Output Skew ⁽³⁾	Rising edges at $V_{DD}/2$	—	—	250	ps

NOTES:

1. With external series resistor of 33Ω positioned close to each output pin.
2. With rail-to-rail input clock.
3. Between any two outputs with equal loading.
4. Duty cycle on outputs will match incoming clock duty cycle. Consult IDT for tight duty cycle clock generators.

TEST CIRCUIT

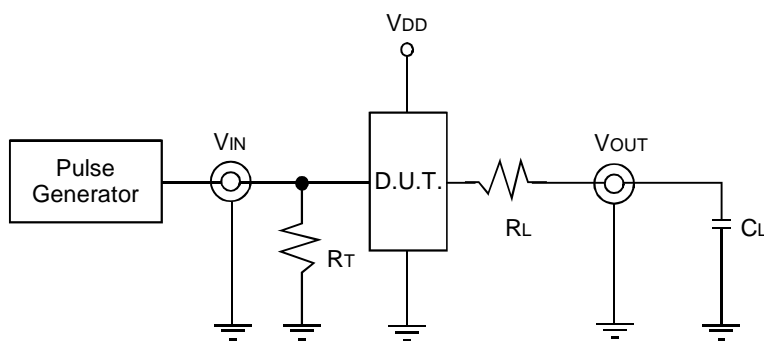

TEST CONDITIONS

Symbol	$V_{DD} = 3.3\text{V} \pm 5\%$	Unit
C_L	15	pF
R_T	Z_{out} of pulse generator	Ω
R_L	33	Ω
t_r/t_f	1 (0V to 3V or 3V to 0V)	ns

DEFINITIONS:

C_L = Load capacitance: includes jig and probe capacitance.

R_T = Termination resistance: should be equal to the Z_{out} of the pulse generator.

t_r/t_f = Rise/Fall time of the input stimulus from the pulse generator.

ORDERING INFORMATION

<u>Part Number</u>	<u>Shipping Package</u>	<u>Package</u>	<u>Temperature</u>
5V551DCGI	Tubes	8SOIC	-40 to +85°C
5V551DCGI8	Tape and Reel	8SOIC	-40 to +85°C

IMPORTANT NOTICE AND DISCLAIMER

RENESAS ELECTRONICS CORPORATION AND ITS SUBSIDIARIES (“RENESAS”) PROVIDES TECHNICAL SPECIFICATIONS AND RELIABILITY DATA (INCLUDING DATASHEETS), DESIGN RESOURCES (INCLUDING REFERENCE DESIGNS), APPLICATION OR OTHER DESIGN ADVICE, WEB TOOLS, SAFETY INFORMATION, AND OTHER RESOURCES “AS IS” AND WITH ALL FAULTS, AND DISCLAIMS ALL WARRANTIES, EXPRESS OR IMPLIED, INCLUDING, WITHOUT LIMITATION, ANY IMPLIED WARRANTIES OF MERCHANTABILITY, FITNESS FOR A PARTICULAR PURPOSE, OR NON-INFRINGEMENT OF THIRD-PARTY INTELLECTUAL PROPERTY RIGHTS.

These resources are intended for developers who are designing with Renesas products. You are solely responsible for (1) selecting the appropriate products for your application, (2) designing, validating, and testing your application, and (3) ensuring your application meets applicable standards, and any other safety, security, or other requirements. These resources are subject to change without notice. Renesas grants you permission to use these resources only to develop an application that uses Renesas products. Other reproduction or use of these resources is strictly prohibited. No license is granted to any other Renesas intellectual property or to any third-party intellectual property. Renesas disclaims responsibility for, and you will fully indemnify Renesas and its representatives against, any claims, damages, costs, losses, or liabilities arising from your use of these resources. Renesas' products are provided only subject to Renesas' Terms and Conditions of Sale or other applicable terms agreed to in writing. No use of any Renesas resources expands or otherwise alters any applicable warranties or warranty disclaimers for these products.

(Disclaimer Rev.1.01 Jan 2024)

Corporate Headquarters

TOYOSU FORESIA, 3-2-24 Toyosu,
Koto-ku, Tokyo 135-0061, Japan
www.renesas.com

Trademarks

Renesas and the Renesas logo are trademarks of Renesas Electronics Corporation. All trademarks and registered trademarks are the property of their respective owners.

Contact Information

For further information on a product, technology, the most up-to-date version of a document, or your nearest sales office, please visit www.renesas.com/contact-us/.