

Description

The 5L2503 MicroClock programmable clock generator is intended for low-power, consumer, wearable and smart devices.

The 5L2503 device is a 3 PLL architecture design. Each PLL is individually programmable, allowing up to 3 unique frequency outputs. The 5L2503 has built-in unique features such as Proactive Power Saving (PPS) to deliver better system level power management.

An internal OTP memory allows the user to store the configuration in the device without programming after power-up, and then can be reprogrammed again through the I²C interface.

The device has programmable VCO and PLL source selection allowing the user to do power-performance optimization based on the application requirements. A low-power 32.768kHz clock is supported with only less than 2µA current consumption for system RTC reference clock needs.

Typical Applications

- SmartDevice
- Handheld
- Wearable applications
- Consumer application crystal replacements

Block Diagram

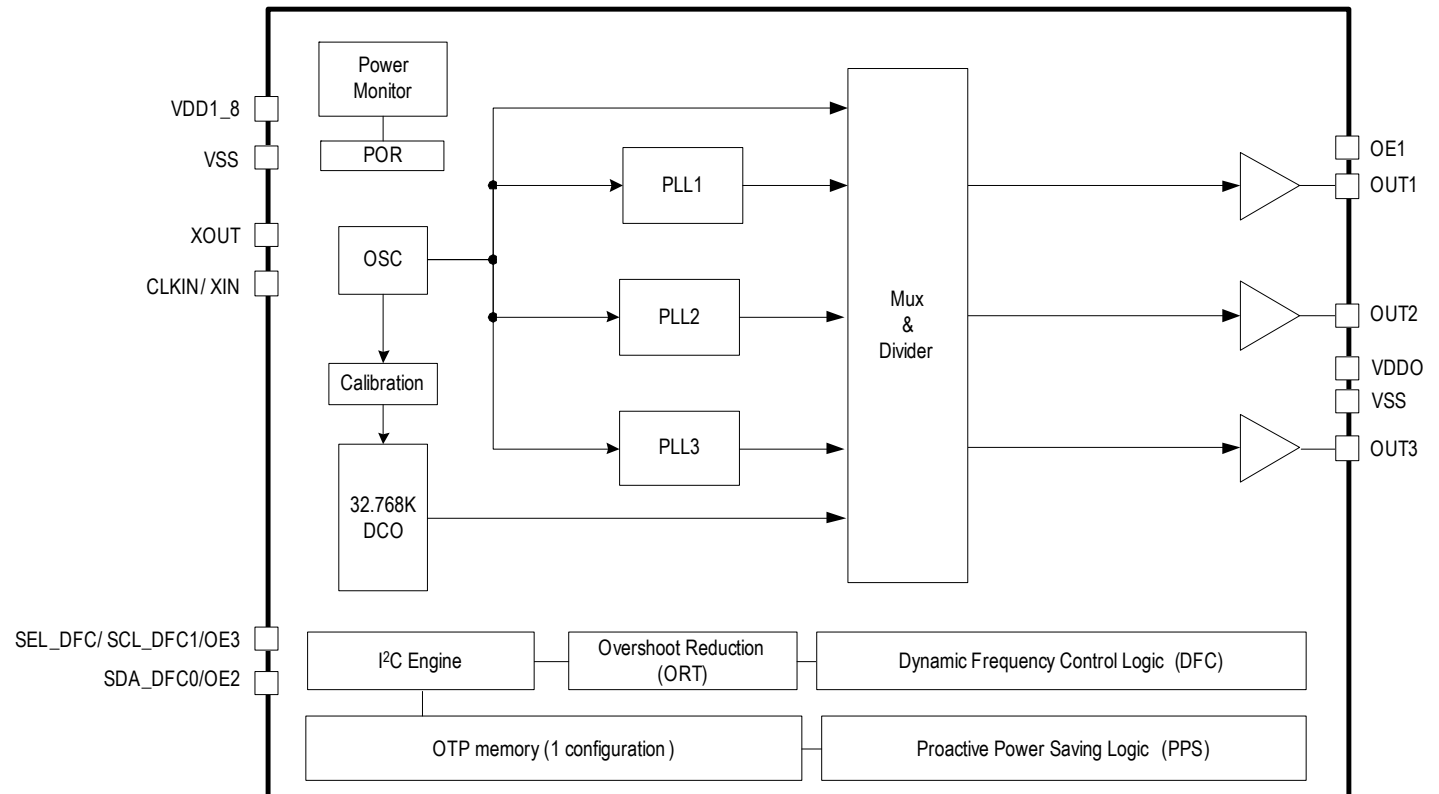

Features

- Configurable OE1 pin function as OE, PPS or DFC control function
- Proactive Power Saving (PPS) features save power during the end device power down mode
- Dynamic Frequency Control (DFC) feature allows programming up to 4 difference frequencies switch dynamically
- Spread spectrum clock support to lower system EMI
- I²C Interface

Output Features

- 3 LVCMOS outputs: 1MHz–125MHz
- Low Power 32.768kHz clock supported
- Wireless clock crystal integration and fan out directly

Key Specifications

- 2µA operation for RTC clock 32.768kHz output
- 2.5 × 2.5 mm 12-DFN small form factor package

Pin Assignments

Figure 1. Pin Assignments for 2.5 × 2.5 mm 12-DFN – Top View

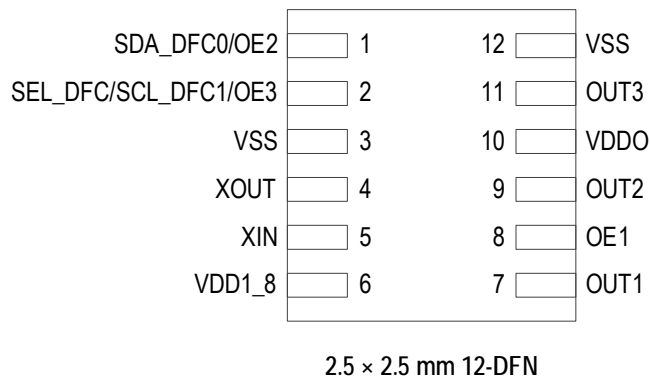

Pin Descriptions

Table 1. Pin Descriptions

Number	Name	Type	Description
1	SDA_DFC0/OE2	I/O	I ² C data pin; can be DFC0 function by OTP programming or selected by SEL_DFC at power-on default. Output enable pin for OUT2.
2	SEL_DFC/SCL_DFC1/OE3	Input	I ² C clock pin; can be DFC1 function by OTP programming selected by SEL_DFC at power-on default. Output enable pin for OUT3.
3	V _{SS}	Power	Ground pin.
4	XOUT	I/O	Crystal oscillator interface output.
5	XIN	Input	Crystal oscillator interface input or clock input pin (CLKIN).
6	V _{DD1_8}	Power	1.8V power rail.
7	OUT1	Output	1.8V LVCMOS clock output.
8	OE1	Input	Output enable control 1.
9	OUT2	Output	1.8V LVCMOS clock output.
10	V _{DDO}	Power	1.8V output clock power supply pin; supports OUT2/3.
11	OUT3	Output	1.8V LVCMOS clock output.
12	V _{SS}	Power	Ground pin.
	EPAD	Power	Connect to ground pad.

Power Group

Table 2. Power Group

Power Supply	SE	DIV	MUX	PLL	DCO	XTAL
V _{DD0}	OUT2/OUT3			V		
V _{DD1_8}	OUT1	V	V		V	V

Output Source Selection Register Settings

Table 3. OUT3 Source

OUT3 Source	B35b7	B35b6
Divider 3 (DIV3)	0	0
Divider 5 (DIV5)	0	1
Divider 1 (DIV1)	1	0
32.768kHz DCO	1	1

Table 4. OUT2 Source

OUT2 Source	B35b5	B35b4
Divider 3 (DIV3)	0	0
Divider 5 (DIV5)	0	1
Divider 1 (DIV1)	1	0
32.768kHz DCO	1	1

Table 5. OUT1 Source

OUT1 source	B35b3	B35b2
Divider 3 (DIV3)	0	0
Divider 5 (DIV5)	0	1
Divider 1 (DIV1)	1	0
32.768kHz DCO	1	1

Table 6. DIV1 Source

DIV1 source	B35b1	B35b0
PLL1	0	0
DIV4 seed	1	X

Device Features and Functions

DFC – Dynamic Frequency Control

- OTP programmable—4 different feedback fractional dividers (4 VCO frequencies) that apply to PLL2.
- ORT (overshoot reduction) function will be applied automatically during the VCO frequency change.
- Smooth frequency incremental or decremental from current VCO to targeted VCO base on DFC hardware pins selection.

Figure 2. DFC Function Block Diagram

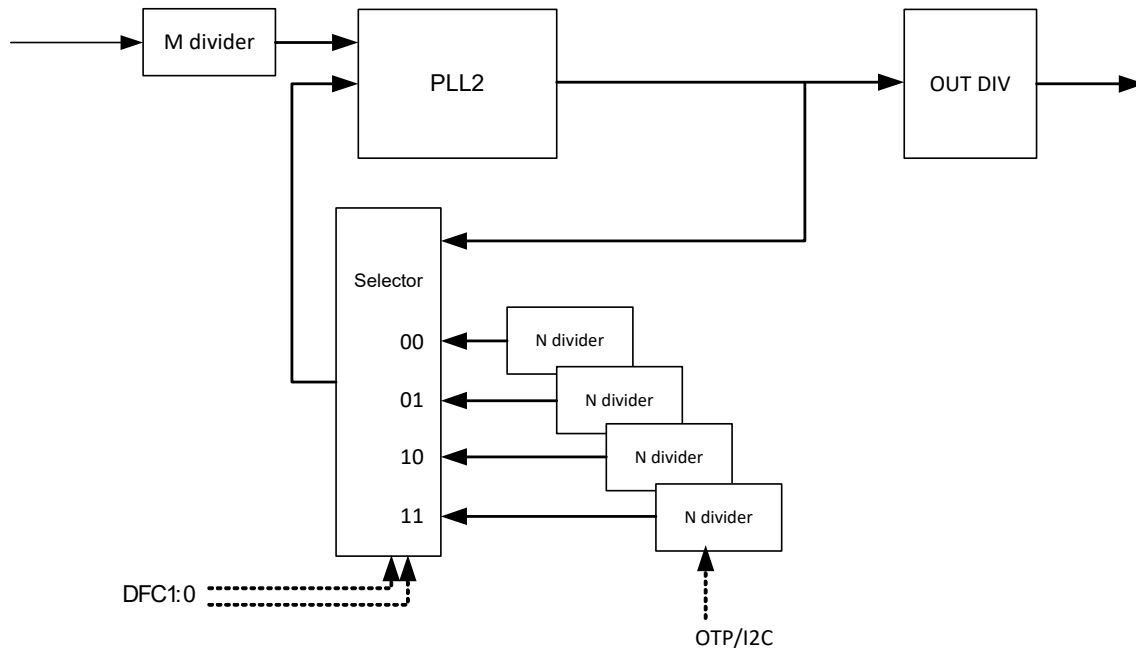

Table 7. DFC Function Priority

DFC Mode	OE Pin	DFC_EN bit (W32[4])	OE1_fun_sel	I ² C Pins	SCL_DFC1	SDA_DFC0	DFC[1:0]	Notes
Off	OE In *	0	00 or 01 or 10 *	Active (SCL = 1 at POR)	SCL input	SDA I/O	Not applicable	DFC disable
On	DFC0 In	1	11	Active	SCL input	SDA I/O	DFC0 = OE	One pin DFC via OE1
On	OE In *	1	00 or 01 or 10 *	Inactive (SCL= 0 at POR)	DFC1	DFC0	DFC1 = SCL_DFC1	I ² C pin as DFC control pins
On	OE In *	1	00 or 01 or 10 *	Active (SCL = 1 at POR)	SCL input	SDA I/O	W30[1:0]	I ² C control DFC mode

* See OE Pin Function table.

DFC Function Programming

- Register B63b3:2 select DFC00–DFC11 configuration.
- Byte16–19 are the register for PLL2 VCO setting. Based on B63b3:2 configuration selection, the data write to B16–19 will be stored in selected configuration OTP memory.
- Refer to *DFC Function Priority* table; select proper control pin(s) to activate DFC function.
- Note the DFC function can also be controlled by I²C access.

PPS – Proactive Power Saving Function

PPS Proactive Power Saving is an IDT patented unique design for the clock generator that proactively detects end device power-down state and then switches output clocks between normal operation clock frequency and low power mode 32kHz clock that only consumes < 5µA current. The system could save power when the device goes into power-down or sleep mode. The PPS function diagram is shown below.

Figure 3. PPS Function Block Diagram

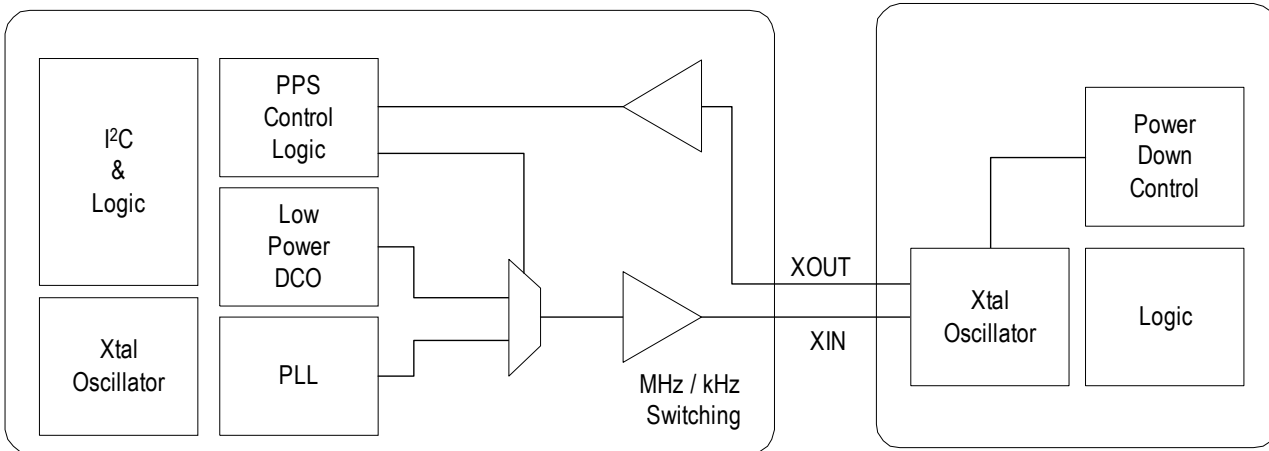
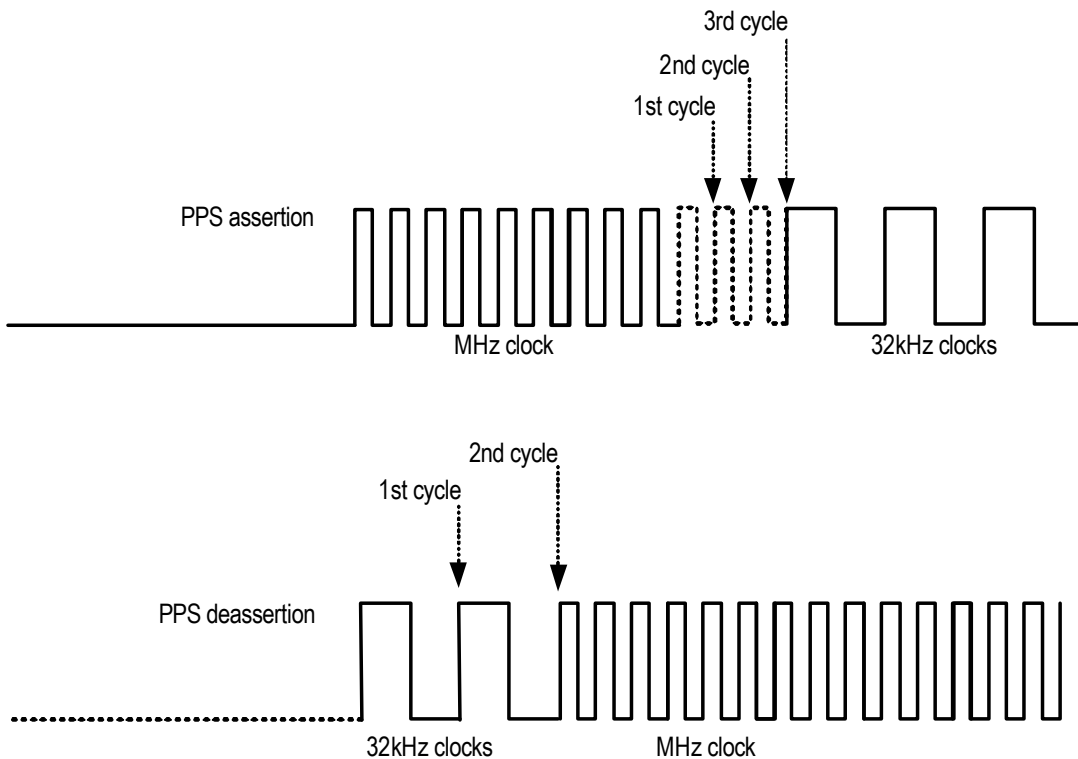

Figure 4. PPS Assertion/Deassertion Timing Chart



PPS Function Programming

- Refer to OE_pin_function_table to have proper PPS function selected for OE pin(s); note that register default is set to Output Enable (OE) function for OE pins.

Input Pin Function

The input pins in 5L2503 have multiple functions. The OE1 pin can be configured as output enable control (OE) or chip power-down control (PD#) or Proactive Power Saving function (PPS). Furthermore, the OE1 pin can be configured as a single or two-pin Dynamic Frequency Control (DFC).

SCL/SDA are also multiple function pins. The two pins can be configured as output enable control (OE), or I²C interface or Dynamic Frequency Control (DFC) functions by programming and hardware pin latch.

Table 8. OE1 Pin Function

Function	Byte30	
	bit6	bit5
OUT1 output enable/disable	0	0
Global Power Down (PD#)	0	1
OUT1 Proactive Power Saving Input (OUT1 PPS)	1	0
DFC0	1	1

Table 9. SDA/SCL Function

SEL_DFC (latched)	Enable OE2/3 B36<2>	DFC_EN B32<4>	OE1 Funsel B30<6:5>	Function of SCL/SDA
0	0	0	00, 01, 10	N/A
0	0	1	00, 01, 10	SCL = DFC1, SDA = DFC0
0	1	X	00, 01, 10	SCL = OE3, SDA = OE2
1	X	X	00, 01, 10	SCL, SDA

Spread Spectrum

The 5L2503 supports spread spectrum clocks from PLL1. PLL1 has built-in analog spread spectrum; PLL2 and PLL3 use seed clock from PLL1.

ORT – VCO Overshoot Reduction Technology

The 5L2503 supports innovate the VCO overshoot reduction technology to prevent the output clock frequency spike when the device is change frequency on the fly or doing DFC (Dynamic Frequency Control) function. The VCO frequency change are under control instead of freerun to targeted frequency.

PLL Features and Descriptions

Table 10. Output Divider 1

Output Divider Bits <1:0>	Output Divider Bits <3:2>			
	00	01	10	11
00	1	2	4	8
01	4	8	16	32
10	5	10	20	40
11	6	12	24	48

Table 11. Output Dividers 2, 3, and 5

Output Divider Bits <1:0>	Output Divider Bits <3:2>			
	00	01	10	11
00	1	2	4	5
01	3	6	12	15
10	5	10	20	25
11	10	20	40	50

Table 12. Output Divider 4

Output Divider Bits <1:0>	Output Divider Bits <3:2>			
	00	01	10	11
00	1	2	4	8
01	4	8	16	32
10	5	10	20	40
11	6	12	24	48

Output Clock Test Conditions

LVC MOS Output Test Conditions

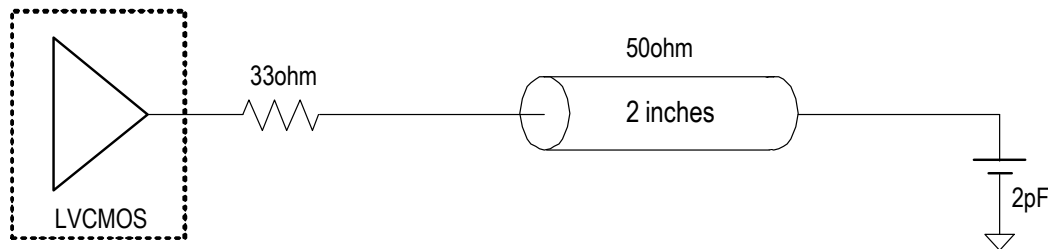

Absolute Maximum Ratings

The absolute maximum ratings are stress ratings only. Stresses greater than those listed below can cause permanent damage to the device. Functional operation of the 5L2503 at absolute maximum ratings is not implied. Exposure to absolute maximum rating conditions may affect device reliability.

Table 13: Absolute Maximum Ratings

Item	Rating
Supply Voltage, V_{DD1_8} , V_{DDOUTx}	1.89V
Inputs	
Other Inputs	-0.5V to V_{DD1_8}/V_{DDOUTx}
Outputs, V_{DDOUTx} (LVCMOS)	-0.5V to $V_{DDOUTx} + 0.5V$
Outputs, IO (SDA)	10mA
Package Thermal Impedance, θ_{JA}	42°C/W (0 mps)
Package Thermal Impedance, θ_{JC}	41.8°C/W (0 mps)
Storage Temperature, T_{STG}	-65°C to 150°C
ESD Human Body Model	2000V
Junction Temperature	125°C

Recommended Operating Conditions

Table 14: Recommended Operating Conditions

Symbol	Parameter	Minimum	Typical	Maximum	Units
V_{DDOUTx}	Power supply voltage for supporting 1.8V output and all other outputs.	1.71	1.8	1.89	V
V_{DD1_8}	Power supply voltage for core logic functions.	1.71	1.8	1.89	V
T_A	Operating temperature, ambient.	-40		85	°C
C_{LOAD_OUT}	Maximum load capacitance (1.8V LVCMOS only).		5		pF
t_{PU}	Power up time for all V_{DDs} to reach minimum specified voltage (power ramps must be monotonic).	0.05		3	ms

Input Capacitance, LVCMOS Output Impedance, and Internal Pull-down Resistance ($T_A = +25\text{ }^\circ\text{C}$)

Table 15: Input Capacitance, LVCMOS Output Impedance, and Internal Pull-down Resistance

Symbol	Parameter	Minimum	Typical	Maximum	Units
C_{IN}	Input Capacitance (OE, SDA, SCL)		3	7	pF
Pull-down Resistor	OE		150		k Ω
R_{OUT}	LVCMOS Output Driver Impedance ($V_{DDOUTx} = 1.8V$)		17		

Recommended Crystal Characteristics

Table 16: Crystal Characteristics

Parameter	Minimum	Typical	Maximum	Units
Mode of Oscillation	Fundamental			
Frequency	8		48	MHz
Frequency Tolerance	-20		20	ppm
Equivalent Series Resistance (ESR)		10	100	Ω
Shunt Capacitance		2	7	pF
Load Capacitance (C_L)	6	8	10	pF
Maximum Crystal Drive Level			100	μW

DC Electrical Characteristics

Table 17: DC Electrical Characteristics

Symbol	Parameter	Conditions	Minimum	Typical	Maximum	Units
I_{DD}	Operation Supply Current	$V_{DD} = V_{DDO} = V_{DD1.8} = 1.8V$; OUT1 = 12MHz, OUT3 = 26MHz, OUT2 off, no load.		2.0		mA
		$V_{DD} = V_{DDO} = V_{DD1.8} = 1.8V$; OUT1 = 12MHz, OUT3 = 26MHz, OUT2 off, with load.		3.5		mA
		$V_{DD} = V_{DDO} = V_{DD1.8} = 1.8V$; OUT1 = 26MHz, OUT3 = 26MHz, OUT2 = 32kHz, no load.		1.8		mA
		$V_{DD} = V_{DDO} = V_{DD1.8} = 1.8V$; OUT1 = 26MHz, OUT3 = 26MHz, OUT2 = 32kHz, with load.		3.8		mA
I_{DDPD}	Power Down Current	PD asserted with $V_{DD1.8}$ and V_{DDO} ON, I ² C programming, 32k running.		390		μA
$I_{DDSUSPEND}$	Power Suspend Current	$V_{DDO}OUT2$ OFF and only $V_{DDO}OUT1$ and $V_{DD1.8}$ ON, I ² C programming, 32k running.		1.6	2.0	μA

¹ Single CMOS driver active.

² OUT1–3 current measured with 0.5 inches transmission line and no load.

DC Electrical Characteristics for 1.8V LVCMOS

$V_{DD} = 1.8V \pm 5\%$, $V_{DDOUTx} = 1.8V \pm 5\%$, $T_A = -40^\circ C$ to $85^\circ C$.

Table 18: DC Electrical Characteristics for 1.8V LVCMOS

Symbol	Parameter	Conditions	Minimum	Typical	Maximum	Units
V_{OH}	Output High Voltage	$I_{OH} = -8mA$.	$0.7 \times V_{DDOUTx}$		V_{DDOUTx}	V
V_{OL}	Output Low Voltage	$I_{OL} = 8mA$.			$0.25 \times V_{DDOUTx}$	V
I_{OZDD}	Output Leakage Current	Tri-state outputs, $V_{DDOUTx} = 1.89V$.			3	μA
V_{IH}	Input High Voltage	Single-ended inputs – OE1, SDA, SCL.	$0.65 \times V_{DDOUTx}$		$V_{DDOUTx} + 0.3$	V
V_{IL}	Input Low Voltage	Single-ended inputs – OE1, SDA, SCL.	GND - 0.3		$0.35 \times V_{DDOUTx}$	V
I_{IN}	Input Leakage Current	OE1	-1		5	μA

AC Electrical Characteristics

$V_{DD1,8} = 1.8V \pm 5\%$, $V_{DDO} = 1.8V \pm 5\%$, $T_A = -40^\circ C$ to $85^\circ C$; spread spectrum = off.

Table 19. AC Electrical Characteristics

Symbol	Parameter	Conditions	Minimum	Typical	Maximum	Units
f_{IN}^1	Input Frequency	Input frequency limit when using a crystal.	8		48	MHz
		Input frequency limit when using LVCMOS connected to XIN.	1		125	MHz
f_{OUT}	Output Frequency	Single-ended clock output limit (LVCMOS).	1		125	MHz
t1	Output Duty Cycle	LVCMOS clock < 120MHz.	45		55	%
t2	Rise/Fall Time	Single-ended LVCMOS output clock rise and fall time, 20% to 80% of $V_{DDO} 1.8V$.		1.0		ns

Table 19. AC Electrical Characteristics (Cont.)

Symbol	Parameter	Conditions	Minimum	Typical	Maximum	Units
t3	Clock Jitter	Cycle-to-cycle jitter (peak-to-peak), multiple output frequencies switching, differential outputs (1.8V nominal output voltage). OUT1 = 25MHz. OUT2 = 100MHz. OUT3 = 125MHz.		50	200	ps
	Clock Jitter	Cycle-to-cycle jitter (peak-to-peak), multiple output frequencies switching, differential outputs (1.8V nominal output voltage). OUT1 = 24MHz. OUT2 = 32.768kHz. OUT3 = 26MHz.		50	200	ps
	Clock Jitter	Cycle-to-cycle jitter (peak-to-peak), multiple output frequencies switching, differential outputs (1.8V nominal output voltage). OUT1 = 32.768kHz. OUT2 = 26MHz. OUT3 = 26MHz.		50	200	ps
t5 ²	Lock Time	PLL lock time from power-up.			20	ms
t6	Lock Time	32.768kHz clock low-power, power-up time.		10	100	ms
t6 ³	Lock Time	PLL lock time from shutdown mode.		0.1	2	ms

¹ Practical lower frequency is determined by loop filter settings.

² Includes loading the configuration bits from OTP to PLL registers. It does not include OTP programming/write time.

³ Actual PLL lock time depends on the loop configuration.

I²C Bus Characteristics

Table 20. I²C Bus DC Characteristics

Symbol	Parameter	Conditions	Minimum	Typical	Maximum	Units
V _{IH}	Input High Level		0.7 × V _{DD1_8}			V
V _{IL}	Input Low Level				0.3 × V _{DD1_8}	V
V _{HYS}	Hysteresis of Inputs		0.05 × V _{DD1_8}			V
I _{IN}	Input Leakage Current				±1	μA
V _{OL}	Output Low Voltage	I _{OL} = 3mA.			0.4	V

Table 21. I²C Bus AC Characteristics

Symbol	Parameter	Conditions	Minimum	Typical	Maximum	Units
F _{SCLK}	Serial Clock Frequency (SCL)			100	400	kHz
t _{BUF}	Bus Free-time between STOP and START		1.3			μs
t _{SU:START}	Setup Time, START		0.6			μs
t _{HD:START}	Hold Time, START		0.6			μs
t _{SU:DATA}	Setup Time, Data Input (SDA)		100			μs
t _{HD:DATA}	Hold Time, Data Input (SDA) 1		0			μs
t _{OVD}	Output Data Valid from Clock				0.9	μs
C _B	Capacitive Load for each Bus Line				400	pF
t _R	Rise Time, Data and Clock (SDA, SCL)		20 + 0.1 × C _B		300	ns
t _F	Fall Time, Data and Clock (SDA, SCL)		20 + 0.1 × C _B		300	ns
t _{HIGH}	High Time, Clock (SCL)		0.6			μs
t _{LOW}	Low Time, Clock (SCL)		1.3			μs
t _{SU:STOP}	Setup Time, STOP		0.6			μs

¹ A device must internally provide a hold time of at least 300ns for the SDA signal (referred to the V_{IH(MIN)} of the SCL signal) to bridge the undefined region of the falling edge of SCL.

Spread Spectrum Generation Specifications

Table 22: Spread Spectrum Generation Specifications

Symbol	Parameter	Description	Minimum	Typical	Maximum	Units
f _{OUT}	Output Frequency	Output frequency range.	1		125	MHz
f _{MOD}	Modulation Frequency	Modulation frequency.	30 to 63			kHz
f _{SPREAD}	Spread Value	Amount of spread value (programmable) – down spread.	-0.5% to -2%			%f _{OUT}
% tolerance	Spread% Value	Variation of spread range.		15		%

General I²C Serial Interface Information

How to Write

- Controller (host) sends a start bit
- Controller (host) sends the write address
- IDT clock will acknowledge
- Controller (host) sends the beginning byte location = N
- IDT clock will acknowledge
- Controller (host) sends the byte count = X
- IDT clock will acknowledge
- Controller (host) starts sending Byte N through Byte N+X-1
- IDT clock will acknowledge each byte one at a time
- Controller (host) sends a stop bit

Index Block Write Operation			
Controller (Host)		IDT (Slave/Receiver)	
T	starT bit		
Slave Address			
WR	WRite		
		ACK	
Beginning Byte = N			
		ACK	
Data Byte Count = X			
		ACK	
Beginning Byte N		X Byte	
			ACK
O			O
O			O
O			O
Byte N + X - 1			
		ACK	
P	stoP bit		

How to Read

- Controller (host) will send a start bit
- Controller (host) sends the write address
- IDT clock will acknowledge
- Controller (host) sends the beginning byte location = N
- IDT clock will acknowledge
- Controller (host) will send a separate start bit
- Controller (host) sends the read address
- IDT clock will acknowledge
- IDT clock will send the data byte count = X
- IDT clock sends Byte N+X-1
- IDT clock sends Byte 0 through Byte X (if X_(H) was written to Byte 8)
- Controller (host) will need to acknowledge each byte
- Controller (host) will send a not acknowledge bit
- Controller (host) will send a stop bit

Index Block Read Operation		
Controller (Host)		IDT (Slave/Receiver)
T	starT bit	
Slave Address		
WR	WRite	
		ACK
Beginning Byte = N		
		ACK
RT	Repeat starT	
Slave Address		
RD	ReaD	
		ACK
		Data Byte Count=X
ACK		
ACK		Beginning Byte N
		O
O		O
O		O
O		
		Byte N + X - 1
N	Not acknowledge	
P	stoP bit	

Byte 0: General Control

Byte 00h	Name	Control Function	Type	0	1	PWD
Bit 7	OTP_Burned	OTP memory programming indication	R/W	OTP memory non-programmed	OTP memory programmed	0
Bit 6	I2C_addr[1]	I ² C address select bit 1	R/W	00: D0 / 01: D2 10: D4 / 11: D6		0
Bit 5	I2C_addr[0]	I ² C address select bit 0	R/W			0
Bit 4	PLL1_SSEN	PLL1 Spread Spectrum enable	R/W	disable	enable	0
Bit 3	Reserved					0
Bit 2	PLL3_refin_sel	PLL3 source selection	R/W	Xtal	Seed (DIV2)	0
Bit 1	Reserved					0
Bit 0	OTP_protect	OTP memory protection	R/W	read/write	write locked	0

Byte 1: Dash Code ID (optional)

Byte 01h	Name	Control Function	Type	0	1	PWD
Bit 7	DashCode ID[7]	Dash code ID	R/W	—	—	0
Bit 6	DashCode ID[6]	Dash code ID	R/W	—	—	0
Bit 5	DashCode ID[5]	Dash code ID	R/W	—	—	0
Bit 4	DashCode ID[4]	Dash code ID	R/W	—	—	0
Bit 3	DashCode ID[3]	Dash code ID	R/W	—	—	0
Bit 2	DashCode ID[2]	Dash code ID	R/W	—	—	0
Bit 1	DashCode ID[1]	Dash code ID	R/W	—	—	0
Bit 0	DashCode ID[0]	Dash code ID	R/W	—	—	0

Byte 2: Crystal Cap Setting

Byte 02h	Name	Control Function	Type	0	1	PWD
Bit 7	Reserved					0
Bit 6	Reserved					0
Bit 5	Reserved					0
Bit 4	Reserved					1
Bit 3	Reserved					0
Bit 2	Reserved					0
Bit 1	Reserved					0
Bit 0	Reserved					0

Byte 3: PLL3 M Divider

Byte 03h	Name	Control Function	Type	0	1	PWD
Bit 7	PLL3_MDIV1	PLL3 source clock divider	R/W	disable M DIV1	bypadd divider (/1)	0
Bit 6	PLL3_MDIV2	PLL3 source clock divider	R/W	disable M DIV2	bypadd divider (/2)	0
Bit 5	PLL3 M_DIV[5]	PLL3 reference integer divider	R/W	3–64, default 26		0
Bit 4	PLL3 M_DIV[4]	PLL3 reference integer divider	R/W			1
Bit 3	PLL3 M_DIV[3]	PLL3 reference integer divider	R/W			1
Bit 2	PLL3 M_DIV[2]	PLL3 reference integer divider	R/W			0
Bit 1	PLL3 M_DIV[1]	PLL3 reference integer divider	R/W			1
Bit 0	PLL3 M_DIV[0]	PLL3 reference integer divider	R/W			0

Byte 4: PLL3 N Divider

Byte 04h	Name	Control Function	Type	0	1	PWD
Bit 7	PLL3 N_DIV[7]	PLL3 VCO feedback integer divider bit7	R/W	12–2048, default VCO setting is 480MHz		1
Bit 6	PLL3 N_DIV[6]	PLL3 VCO feedback integer divider bit6	R/W			1
Bit 5	PLL3 N_DIV[5]	PLL3 VCO feedback integer divider bit5	R/W			1
Bit 4	PLL3 N_DIV[4]	PLL3 VCO feedback integer divider bit4	R/W			0
Bit 3	PLL3 N_DIV[3]	PLL3 VCO feedback integer divider bit3	R/W			0
Bit 2	PLL3 N_DIV[2]	PLL3 VCO feedback integer divider bit2	R/W			0
Bit 1	PLL3 N_DIV[1]	PLL3 VCO feedback integer divider bit1	R/W			0
Bit 0	PLL3 N_DIV[0]	PLL3 VCO feedback integer divider bit0	R/W			0

Byte 5: PLL3 Loop Filter Setting and N Divider 10:8

Byte 05h	Name	Control Function	Type	0	1	PWD
Bit 7	PLL3_R100K	PLL3 Loop filter resister 100kohm	R/W	bypass	plus 100kohm	0
Bit 6	PLL3_R50K	PLL3 Loop filter resister 50kohm	R/W	bypass	plus 50kohm	0
Bit 5	PLL3_R25K	PLL3 Loop filter resister 25kohm	R/W	bypass	plus 25kohm	0
Bit 4	PLL3_R12.5K	PLL3 Loop filter resister 12.5kohm	R/W	bypass	plus 12.5kohm	1
Bit 3	PLL3_R6K	PLL3 Loop filter resister 6kohm	R/W	bypass	only 6kohm applied	0
Bit 2	PLL3 N_DIV[10]	PLL3 VCO feedback integer divider bit10	R/W	12–2048, default VCO setting is 480MHz		0
Bit 1	PLL3 N_DIV[9]	PLL3 VCO feedback integer divider bit9	R/W			0
Bit 0	PLL3 N_DIV[8]	PLL3 VCO feedback integer divider bit8	R/W			1

Byte 6: PLL3 Charge Pump Control

Byte 06h	Name	Control Function	Type	0	1	PWD
Bit 7	OUTDIV 3 Source	Output divider 3 source clock selection	R/W	PLL2	PLL3	0
Bit 6	PLL3_CP_8X	PLL3 charge pump control	R/W	—	x8	1
Bit 5	PLL3_CP_4X	PLL3 charge pump control	R/W	—	x4	1
Bit 4	PLL3_CP_2X	PLL3 charge pump control	R/W	—	x2	0
Bit 3	PLL3_CP_1X	PLL3 charge pump control	R/W	—	x1	1
Bit 2	PLL3_CP_/24	PLL3 charge pump control	R/W	—	/24	1
Bit 1	PLL3_CP_/3	PLL3 charge pump control	R/W	—	/3	0
Bit 0	PLL3_SIREF	PLL3 SiRef current selection	R/W	10μA	20μA	0

Formula: $(i_{Ref} (10\mu A) \times (1 + SIREF) \times (1 \times 1X + 2 \times 2X + 4 \times 4X + 8 \times 8X + 16 \times 16X)) / ((24 \times /24) + (3 \times /3))$

Byte 7: PLL1 Control and OUTDIV5 Divider

Byte 07h	Name	Control Function	Type	0	1	PWD
Bit 7	PLL1_MDIV_Doubler	PLL1 reference clock doubler	R/W	disable	enable	0
Bit 6	PLL1_SIREF	PLL1 SiRef current selection	R/W	10.8μA	21.6μA	0
Bit 5	PLL1_EN_CH2	PLL1 output Channel 2 control	R/W	disable	enable	1
Bit 4	PLL1_EN_3rdpole	PLL1 3rd Pole control	R/W	disable	enable	0
Bit 3	OUTDIV5[3]	Output divider 5 control bit 3	R/W	DIV5[3:2] = 1,2,4,5; DIV5[1:0] = 1,3,5,10; Default Divider = 1 x 10 = 10		0
Bit 2	OUTDIV5[2]	Output divider 5 control bit 2	R/W			0
Bit 1	OUTDIV5[1]	Output divider 5 control bit 1	R/W			1
Bit 0	OUTDIV5[0]	Output divider 5 control bit 0	R/W			1

Byte 8: PLL1 M Divider

Byte 08h	Name	Control Function	Type	0	1	PWD
Bit 7	PLL1_MDIV1	PLL3 VCO reference clock divider 1	R/W	disable M DIV1	bypass divider (/1)	0
Bit 6	PLL1_MDIV2	PLL3 VCO reference clock divider 2	R/W	disable M DIV2	bypass divider (/2)	0
Bit 5	PLL1 M_DIV[5]	PLL1 reference clock divider control bit 5	R/W	3–64, default is 26		0
Bit 4	PLL1 M_DIV[4]	PLL1 reference clock divider control bit 4	R/W			1
Bit 3	PLL1 M_DIV[3]	PLL1 reference clock divider control bit 3	R/W			1
Bit 2	PLL1 M_DIV[2]	PLL1 reference clock divider control bit 2	R/W			0
Bit 1	PLL1 M_DIV[1]	PLL1 reference clock divider control bit 1	R/W			1
Bit 0	PLL1 M_DIV[0]	PLL1 reference clock divider control bit 0	R/W			0

Byte 9: PLL1 VCO N Divider

Byte 09h	Name	Control Function	Type	0	1	PWD
Bit 7	PLL1 N_DIV[7]	PLL1 VCO feedback divider control bit 7	R/W	12–2048, default is 600		0
Bit 6	PLL1 N_DIV[6]	PLL1 VCO feedback divider control bit 6	R/W			1
Bit 5	PLL1 N_DIV[5]	PLL1 VCO feedback divider control bit 5	R/W			0
Bit 4	PLL1 N_DIV[4]	PLL1 VCO feedback divider control bit 4	R/W			1
Bit 3	PLL1 N_DIV[3]	PLL1 VCO feedback divider control bit 3	R/W			1
Bit 2	PLL1 N_DIV[2]	PLL1 VCO feedback divider control bit 2	R/W			0
Bit 1	PLL1 N_DIV[1]	PLL1 VCO feedback divider control bit 1	R/W			0
Bit 0	PLL1 N_DIV[0]	PLL1 VCO feedback divider control bit 0	R/W			0

Byte 10: PLL Loop Filter and N Divider

Byte 0Ah	Name	Control Function	Type	0	1	PWD
Bit 7	PLL1_R100K	PLL1 Loop filter resister 100kohm	R/W	bypass	plus 100kohm	1
Bit 6	PLL1_R50K	PLL1 Loop filter resister 50kohm	R/W	bypass	plus 50kohm	0
Bit 5	PLL1_R25K	PLL1 Loop filter resister 25kohm	R/W	bypass	plus 25kohm	1
Bit 4	PLL1_R12.5K	PLL1 Loop filter resister 12.5kohm	R/W	bypass	plus 12.5kohm	1
Bit 3	PLL1_R1.0K	PLL1 Loop filter resister 1kohm	R/W	bypass	only 1.0kohm applied	0
Bit 2	PLL1 N_DIV[10]	PLL1 VCO feedback integer divider bit10	R/W	12–2048, default is 600		0
Bit 1	PLL1 N_DIV[9]	PLL1 VCO feedback integer divider bit9	R/W			1
Bit 0	PLL1 N_DIV[8]	PLL1 VCO feedback integer divider bit8	R/W			0

Byte 11: PLL1 Charge Pump

Byte 0Bh	Name	Control Function	Type	0	1	PWD
Bit 7	PLL1_CP_32X	PLL1 charge pump control	R/W	—	x32	0
Bit 6	PLL1_CP_16X	PLL1 charge pump control	R/W	—	x16	0
Bit 5	PLL1_CP_8X	PLL1 charge pump control	R/W	—	x8	0
Bit 4	PLL1_CP_4X	PLL1 charge pump control	R/W	—	x4	0
Bit 3	PLL1_CP_2X	PLL1 charge pump control	R/W	—	x2	0
Bit 2	PLL1_CP_1X	PLL1 charge pump control	R/W	—	x1	1
Bit 1	PLL1_CP_/24	PLL1 charge pump control	R/W	—	/24	1
Bit 0	PLL1_CP_/3	PLL1 charge pump control	R/W	—	/3	0

Byte 12: PLL1 Spread Spectrum Control

Byte 0Ch	Name	Control Function	Type	0	1	PWD
Bit 7	PLL1_SS_REFDIV[23]	PLL1 spread spectrum control - Ref divider 23	R/W	—	—	0
Bit 6	PLL1_SS_REFDIV[6]	PLL1 spread spectrum control - Ref divider 6	R/W	—	—	0
Bit 5	PLL1_SS_REFDIV[5]	PLL1 spread spectrum control - Ref divider 5	R/W	—	—	0
Bit 4	PLL1_SS_REFDIV[4]	PLL1 spread spectrum control - Ref divider 4	R/W	—	—	0
Bit 3	PLL1_SS_REFDIV[3]	PLL1 spread spectrum control - Ref divider 3	R/W	—	—	0
Bit 2	PLL1_SS_REFDIV[2]	PLL1 spread spectrum control - Ref divider 2	R/W	—	—	0
Bit 1	PLL1_SS_REFDIV[1]	PLL1 spread spectrum control - Ref divider 1	R/W	—	—	0
Bit 0	PLL1_SS_REFDIV[0]	PLL1 spread spectrum control - Ref divider 0	R/W	—	—	0

Byte 13: PLL1 Spread Spectrum Control

Byte 0Dh	Name	Control Function	Type	0	1	PWD
Bit 7	PLL1_SS_FBDIV[7]	PLL1 spread spectrum - feedback divider 7	R/W	—	—	0
Bit 6	PLL1_SS_FBDIV[6]	PLL1 spread spectrum - feedback divider 6	R/W	—	—	0
Bit 5	PLL1_SS_FBDIV[5]	PLL1 spread spectrum - feedback divider 5	R/W	—	—	0
Bit 4	PLL1_SS_FBDIV[4]	PLL1 spread spectrum - feedback divider 4	R/W	—	—	0
Bit 3	PLL1_SS_FBDIV[3]	PLL1 spread spectrum - feedback divider 3	R/W	—	—	0
Bit 2	PLL1_SS_FBDIV[2]	PLL1 spread spectrum - feedback divider 2	R/W	—	—	0
Bit 1	PLL1_SS_FBDIV[1]	PLL1 spread spectrum - feedback divider 1	R/W	—	—	0
Bit 0	PLL1_SS_FBDIV[0]	PLL1 spread spectrum - feedback divider 0	R/W	—	—	0

Byte 14: PLL1 Spread Spectrum Control

Byte 0Eh	Name	Control Function	Type	0	1	PWD
Bit 7	PLL1_SS_FBDIV[15]	PLL1 spread spectrum - feedback divider 15	R/W	—	—	0
Bit 6	PLL1_SS_FBDIV[14]	PLL1 spread spectrum - feedback divider 14	R/W	—	—	0
Bit 5	PLL1_SS_FBDIV[13]	PLL1 spread spectrum - feedback divider 13	R/W	—	—	0
Bit 4	PLL1_SS_FBDIV[12]	PLL1 spread spectrum - feedback divider 12	R/W	—	—	0
Bit 3	PLL1_SS_FBDIV[11]	PLL1 spread spectrum - feedback divider 11	R/W	—	—	0
Bit 2	PLL1_SS_FBDIV[10]	PLL1 spread spectrum - feedback divider 10	R/W	—	—	0
Bit 1	PLL1_SS_FBDIV[09]	PLL1 spread spectrum - feedback divider 9	R/W	—	—	0
Bit 0	PLL1_SS_FBDIV[08]	PLL1 spread spectrum - feedback divider 8	R/W	—	—	0

Byte 15: Output Divider1 Control

Byte 0Fh	Name	Control Function	Type	0	1	PWD
Bit 7	OUTDIV1[3]	Output divider1 control bit 3	R/W	DIV1[3:2] = 1,2,4,8; DIV1[1:0] = 1,4,5,6; Default Divider = 1 x 1 = 1		0
Bit 6	OUTDIV1[2]	Output divider1 control bit 2	R/W			0
Bit 5	OUTDIV1[1]	Output divider1 control bit 1	R/W			0
Bit 4	OUTDIV1[0]	Output divider1 control bit 0	R/W			0
Bit 3	OUTDIV2[3]	Output divider2 control bit 3	R/W	DIV2[3:2] = 1,2,4,5; DIV2[1:0] = 1,3,5,10; Default Divider = 1 x 10 = 10		0
Bit 2	OUTDIV2[2]	Output divider2 control bit 2	R/W			0
Bit 1	OUTDIV2[1]	Output divider2 control bit 1	R/W			1
Bit 0	OUTDIV2[0]	Output divider2 control bit 0	R/W			1

Byte 16: PLL2 Integer Feedback Divide

Byte 10h	Name	Control Function	Type	0	1	PWD
Bit 7		Reserved				0
Bit 6		Reserved				0
Bit 5		Reserved				0
Bit 4		Reserved				0
Bit 3		Reserved				0
Bit 2	PLL2_FB_INT[10]	PLL2 feedback integer divider 10	R/W	—	—	0
Bit 1	PLL2_FB_INT[9]	PLL2 feedback integer divider 9	R/W	—	—	0
Bit 0	PLL2_FB_INT[8]	PLL2 feedback integer divider 8	R/W	—	—	0

Byte 17: PLL2 Integer Feedback Divider

Byte 11h	Name	Control Function	Type	0	1	PWD
Bit 7	PLL2_FB_INT_DIV[7]	PLL2 feedback integer divider 7	R/W	—	—	0
Bit 6	PLL2_FB_INT_DIV[6]	PLL2 feedback integer divider 6	R/W	—	—	0
Bit 5	PLL2_FB_INT_DIV[5]	PLL2 feedback integer divider 5	R/W	—	—	1
Bit 4	PLL2_FB_INT_DIV[4]	PLL2 feedback integer divider 4	R/W	—	—	1
Bit 3	PLL2_FB_INT_DIV[3]	PLL2 feedback integer divider 3	R/W	—	—	1
Bit 2	PLL2_FB_INT_DIV[2]	PLL2 feedback integer divider 2	R/W	—	—	1
Bit 1	PLL2_FB_INT_DIV[1]	PLL2 feedback integer divider 1	R/W	—	—	0
Bit 0	PLL2_FB_INT_DIV[0]	PLL2 feedback integer divider 0	R/W	—	—	0

Byte 18: PLL2 Fractional Feedback Divider

Byte 12h	Name	Control Function	Type	0	1	PWD
Bit 7	PLL2_FB_FRC_DIV[7]	PLL2 feedback fractional divider 7	R/W	—	—	0
Bit 6	PLL2_FB_FRC_DIV[6]	PLL2 feedback fractional divider 6	R/W	—	—	0
Bit 5	PLL2_FB_FRC_DIV[5]	PLL2 feedback fractional divider 5	R/W	—	—	0
Bit 4	PLL2_FB_FRC_DIV[4]	PLL2 feedback fractional divider 4	R/W	—	—	0
Bit 3	PLL2_FB_FRC_DIV[3]	PLL2 feedback fractional divider 3	R/W	—	—	0
Bit 2	PLL2_FB_FRC_DIV[2]	PLL2 feedback fractional divider 2	R/W	—	—	0
Bit 1	PLL2_FB_FRC_DIV[1]	PLL2 feedback fractional divider 1	R/W	—	—	0
Bit 0	PLL2_FB_FRC_DIV[0]	PLL2 feedback fractional divider 0	R/W	—	—	0

Byte 19: PLL2 Fractional Feedback Divider

Byte 13h	Name	Control Function	Type	0	1	PWD
Bit 7	PLL2_FB_FRC_DIV[15]	PLL2 feedback fractional divider 15	R/W	—	—	0
Bit 6	PLL2_FB_FRC_DIV[14]	PLL2 feedback fractional divider 14	R/W	—	—	0
Bit 5	PLL2_FB_FRC_DIV[13]	PLL2 feedback fractional divider 13	R/W	—	—	0
Bit 4	PLL2_FB_FRC_DIV[12]	PLL2 feedback fractional divider 12	R/W	—	—	0
Bit 3	PLL2_FB_FRC_DIV[11]	PLL2 feedback fractional divider 11	R/W	—	—	0
Bit 2	PLL2_FB_FRC_DIV[10]	PLL2 feedback fractional divider 10	R/W	—	—	0
Bit 1	PLL2_FB_FRC_DIV[9]	PLL2 feedback fractional divider 9	R/W	—	—	0
Bit 0	PLL2_FB_FRC_DIV[8]	PLL2 feedback fractional divider 8	R/W	—	—	0

Byte 20: PLL2 Spread Spectrum Control

Byte 14h	Name	Control Function	Type	0	1	PWD
Bit 7	PLL2_STEP[7]	PLL2 spread step size control bit 7	R/W	—	—	0
Bit 6	PLL2_STEP[6]	PLL2 spread step size control bit 6	R/W	—	—	0
Bit 5	PLL2_STEP[5]	PLL2 spread step size control bit 5	R/W	—	—	0
Bit 4	PLL2_STEP[4]	PLL2 spread step size control bit 4	R/W	—	—	0
Bit 3	PLL2_STEP[3]	PLL2 spread step size control bit 3	R/W	—	—	0
Bit 2	PLL2_STEP[2]	PLL2 spread step size control bit 2	R/W	—	—	0
Bit 1	PLL2_STEP[1]	PLL2 spread step size control bit 1	R/W	—	—	0
Bit 0	PLL2_STEP[0]	PLL2 spread step size control bit 0	R/W	—	—	0

Byte 21: PLL2 Spread Spectrum Control

Byte 15h	Name	Control Function	Type	0	1	PWD
Bit 7	PLL2_STEP[15]	PLL2 spread step size control bit 15	R/W	—	—	0
Bit 6	PLL2_STEP[14]	PLL2 spread step size control bit 14	R/W	—	—	0
Bit 5	PLL2_STEP[13]	PLL2 spread step size control bit 13	R/W	—	—	0
Bit 4	PLL2_STEP[12]	PLL2 spread step size control bit 12	R/W	—	—	0
Bit 3	PLL2_STEP[11]	PLL2 spread step size control bit 11	R/W	—	—	0
Bit 2	PLL2_STEP[10]	PLL2 spread step size control bit 10	R/W	—	—	0
Bit 1	PLL2_STEP[9]	PLL2 spread step size control bit 9	R/W	—	—	0
Bit 0	PLL2_STEP[8]	PLL2 spread step size control bit 8	R/W	—	—	0

Byte 22: PLL2 Spread Spectrum Control

Byte 16h	Name	Control Function	Type	0	1	PWD
Bit 7	PLL2_STEP_DELTA[7]	PLL2 spread step size control delta bit 7	R/W	—	—	0
Bit 6	PLL2_STEP_DELTA[6]	PLL2 spread step size control delta bit 6	R/W	—	—	0
Bit 5	PLL2_STEP_DELTA[5]	PLL2 spread step size control delta bit 5	R/W	—	—	0
Bit 4	PLL2_STEP_DELTA[4]	PLL2 spread step size control delta bit 4	R/W	—	—	0
Bit 3	PLL2_STEP_DELTA[3]	PLL2 spread step size control delta bit 3	R/W	—	—	0
Bit 2	PLL2_STEP_DELTA[2]	PLL2 spread step size control delta bit 2	R/W	—	—	0
Bit 1	PLL2_STEP_DELTA[1]	PLL2 spread step size control delta bit 1	R/W	—	—	0
Bit 0	PLL2_STEP_DELTA[0]	PLL2 spread step size control delta bit 0	R/W	—	—	0

Byte 23: PLL2 Period Control

Byte 17h	Name	Control Function	Type	0	1	PWD
Bit 7	PLL2_PERIOD[7]	PLL2 period control bit 7	R/W	—	—	0
Bit 6	PLL2_PERIOD[6]	PLL2 period control bit 6	R/W	—	—	0
Bit 5	PLL2_PERIOD[5]	PLL2 period control bit 5	R/W	—	—	0
Bit 4	PLL2_PERIOD[4]	PLL2 period control bit 4	R/W	—	—	0
Bit 3	PLL2_PERIOD[3]	PLL2 period control bit 3	R/W	—	—	0
Bit 2	PLL2_PERIOD[2]	PLL2 period control bit 2	R/W	—	—	0
Bit 1	PLL2_PERIOD[1]	PLL2 period control bit 1	R/W	—	—	0
Bit 0	PLL2_PERIOD[0]	PLL2 period control bit 0	R/W	—	—	0

Byte 24: PLL2 Control Register

Byte 18h	Name	Control Function	Type	0	1	PWD
Bit 7	PLL2_PERIOD[9]	PLL2 period control bit 9	R/W	—	—	0
Bit 6	PLL2_PERIOD[8]	PLL2 period control bit 8	R/W	—	—	0
Bit 5	PLL2_SSEN	PLL2 spread spectrum enable	R/W	disable	enable	0
Bit 4	PLL2_R100K	PLL2 loop filter resister 100kohm	—	bypass	plus 100kohm	0
Bit 3	PLL2_R50K	PLL2 loop filter resister 50kohm	—	bypass	plus 50kohm	1
Bit 2	PLL2_R25K	PLL2 loop filter resister 25kohm	—	bypass	plus 25kohm	1
Bit 1	PLL2_R12.5K	PLL2 loop filter resister 12.5kohm	—	bypass	plus 12.5kohm	1
Bit 0	PLL2_R6K	PLL2 loop filter resister 6kohm	—	bypass	only 6kohm applied	0

Byte 25: PLL2 Charge Pump Control

Byte 19h	Name	Control Function	Type	0	1	PWD
Bit 7	PLL2_CP_16X	PLL2 charge pump control	R/W	—	x16	0
Bit 6	PLL2_CP_8X	PLL2 charge pump control	R/W	—	x8	0
Bit 5	PLL2_CP_4X	PLL2 charge pump control	R/W	—	x4	0
Bit 4	PLL2_CP_2X	PLL2 charge pump control	R/W	—	x2	1
Bit 3	PLL2_CP_1X	PLL2 charge pump control	R/W	—	x1	0
Bit 2	PLL2_CP_/24	PLL2 charge pump control	R/W	—	/24	1
Bit 1	PLL2_CP_/3	PLL2 charge pump control	R/W	—	/3	0
Bit 0	PLL2_SIREF	PLL2 SiRef current selection	R/W	10 μ A	20 μ A	0

Byte 26: PLL2 M Divider Setting

Byte 1Ah	Name	Control Function	Type	0	1	PWD
Bit 7	PLL2_MDIV_Doubler	PLL2 reference divider - doubler	R/W	disable	enable	0
Bit 6	PLL2_MDIV1	PLL2 reference divider 1	R/W	disable M DIV1	bypadd divider (/1)	0
Bit 5	PLL2_MDIV2	PLL2 reference divider 2	R/W	disable M DIV2	bypadd divider (/2)	0
Bit 4	PLL2_MDIV[4]	PLL2 reference divider control bit 4	R/W	3–64, default is 26		1
Bit 3	PLL2_MDIV[3]	PLL2 reference divider control bit 3	R/W			1
Bit 2	PLL2_MDIV[2]	PLL2 reference divider control bit 2	R/W			0
Bit 1	PLL2_MDIV[1]	PLL2 reference divider control bit 1	R/W			1
Bit 0	PLL2_MDIV[0]	PLL2 reference divider control bit 0	R/W			0

Byte 27: Output Divider 4

Byte 1Bh	Name	Control Function	Type	0	1	PWD
Bit 7	OUTDIV3[3]	Out divider 4 control bit 7	R/W	DIV3[3:2] = 1,2,4,5; DIV3[1:0] = 1,3,5,10; Default Divider = 1 x 5 = 5		0
Bit 6	OUTDIV3[2]	Out divider 4 control bit 6	R/W			0
Bit 5	OUTDIV3[1]	Out divider 4 control bit 5	R/W			1
Bit 4	OUTDIV3[0]	Out divider 4 control bit 4	R/W			0
Bit 3	OUTDIV4[3]	Out divider 4 control bit 3	R/W	DIV4[3:2] = 1,2,4,8; DIV4[1:0] = 1,3,5,10; Default Divider = 1 x 10 = 10		0
Bit 2	OUTDIV4[2]	Out divider 4 control bit 2	R/W			0
Bit 1	OUTDIV4[1]	Out divider 4 control bit 1	R/W			1
Bit 0	OUTDIV4[0]	Out divider 4 control bit 0	R/W			1

Byte 28: PLL Operation Control Register

Byte 1Ch	Name	Control Function	Type	0	1	PWD
Bit 7	PLL2_HRS_EN	PLL2 spread high resolution selection enable	R/W	normal	enable (shift 4 bits)	0
Bit 6	PLL2_refin_sel	PLL2 reference clock source select	R/W	Xtal	DIV2	0
Bit 5	PLL3_PDB	PLL3 power down	R/W	power down	running	0
Bit 4	PLL3_LCKBYPSSB	PLL3 lock bypass	R/W	bypass lock	lock	0
Bit 3	PLL2_PDB	PLL2 power down	R/W	power down	running	1
Bit 2	PLL2_LCKBYPSSB	PLL2 lock bypass	R/W	bypass lock	lock	1
Bit 1	PLL1_PDB	PLL1 power down	R/W	power down	running	0
Bit 0	PLL1_LCKBYPSSB	PLL1 lock bypass	R/W	bypass lock	lock	0

Byte 29: Output Control

Byte 1Dh	Name	Control Function	Type	0	1	PWD
Bit 7		Reserved				0
Bit 6		Reserved				0
Bit 5		Reserved				1
Bit 4		Reserved				1
Bit 3		Reserved				0
Bit 2	VDD1_SEL	VDD1_SEL	R/W	1.8V	1.2V	0
Bit 1		Reserved				0
Bit 0		Reserved				0

Byte 30: OE and DFC Control

Byte 1Eh	Name	Control Function	Type	0	1	PWD
Bit 7	OUT1_EN	OUT1 output enable control	R/W	disable	enable	1
Bit 6	OE1_fun_sel[1]	OE1 pin function selection bit 1	R/W	11:DFC0 01: PD#	10: OUT_PPS 00: OUT1 OE	0
Bit 5	OE1_fun_sel[0]	OE1 pin function selection bit 0	R/W			0
Bit 4	Reserved					1
Bit 3	Reserved					1
Bit 2	Reserved					0
Bit 1	DFC_SW_Sel[1]	DFC frequency select bit 1	R/W	00: N0 01: N1 10:N2 11:N3		0
Bit 0	DFC_SW_Sel[0]	DFC frequency select bit 0	R/W			0

Byte 31: Control Register

Byte 1Fh	Name	Control Function	Type	0	1	PWD
Bit 7	OUT2 free run_b	OUT2 free run_b	R/W	freerun	stoppable	1
Bit 6	Reserved					0
Bit 5	Reserved					0
Bit 4	Reserved					0
Bit 3	Reserved					0
Bit 2	PLL2_3rd_EN_CFG	PLL2 3rd order control	R/W	1st order	3rd order	1
Bit 1	OUTDIV5 source	OUTDIV5 source	R/W	PLL3	DIV4seed	0
Bit 0	PLL2_EN_3rdpole	PLL2 3rd pole control	R/W	disable	enable	0

Byte 32: Control Register

Byte 20h	Name	Control Function	Type	0	1	PWD
Bit 7	Reserved					1
Bit 6	OUT2_fun_sel	OUT2 pin function selection	R/W	OE1pin controlled	OE1pin not controlled	1
Bit 5	Reserved					0
Bit 4	DFC_EN	DFC function control	R/W	disable	enable	0
Bit 3	Reserved					0
Bit 2	Reserved					0
Bit 1	Reserved					0
Bit 0	Reserved					0

Byte 33: OUT3 Control Register

Byte 21h	Name	Control Function	Type	0	1	PWD
Bit 7	OUT3 free run_b	OUT3 free run_b	R/W	freerun	stoppable	1
Bit 6		Reserved				0
Bit 5		Reserved				0
Bit 4		Reserved				0
Bit 3		Reserved				0
Bit 2		Reserved				0
Bit 1		Reserved				0
Bit 0		Reserved				0

Byte 34: Control Register

Byte 22h	Name	Control Function	Type	0	1	PWD
Bit 7		Reserved				1
Bit 6		Reserved				1
Bit 5		Reserved				1
Bit 4		Reserved				1
Bit 3		Reserved				0
Bit 2		Reserved				1
Bit 1		Reserved				0
Bit 0		Reserved				0

Byte 35: Control Register

Byte 23h	Name	Control Function	Type	0	1	PWD
Bit 7	OUT3 muxsel1	OUT3 muxsel1	R/W	00: DIV3 01: DIV5 10: DIV1 11: CLK_32K		1
Bit 6	OUT3 muxsel0	OUT3 muxsel0	R/W			0
Bit 5	OUT2 muxsel1	OUT2 muxsel1	R/W	00: DIV3 01: DIV5 10: DIV1 11: CLK_32K		0
Bit 4	OUT2 muxsel0	OUT2 muxsel0	R/W			0
Bit 3	OUT1 muxsel1	OUT1 muxsel1	R/W	00: DIV3 01: DIV5 10: DIV1 11: CLK_32K		1
Bit 2	OUT1 muxsel0	OUT1 muxsel0	R/W			1
Bit 1	DIV1 muxsel1	DIV1 muxsel1	R/W	00: PLL1 01: REF 1x: DIV4outseed		0
Bit 0	DIV1 muxsel0	DIV1 muxsel0	R/W			1

Byte 36: OUT1 and DIV4 control

Byte 24h	Name	Control Function	Type	0	1	PWD
Bit 7	I2C_PDB	Chip power down control bit	R/W	power down	normal	1
Bit 6	Ref_free_run	Reference clock output (OUT2/OUT3)	R/W	stop	freerun	0
Bit 5	free_run_output_config	clocks free run control	R/W	OUT2 free run	OUT2/3 free run	0
Bit 4	Reserved					1
Bit 3	OUT1_Freerun_b	OUT1 free run_b	R/W	freerun	stoppable	1
Bit 2	Enable OE2/3	Enable OE2/OE3 function	R/W	disable	enable	0
Bit 1	DIV4 muxsel1	DIV4 muxsel1	R/W	00: PLL2_CH2 01: PLL3_CH2 10: DIV3seed 11: DIV5seed		1
Bit 0	DIV4 muxsel0	DIV4 muxsel0	R/W			1

Package Drawings

Figure 5. NVG12, 2.5 × 2.5 mm 12-DFN Package Drawing – Page 1

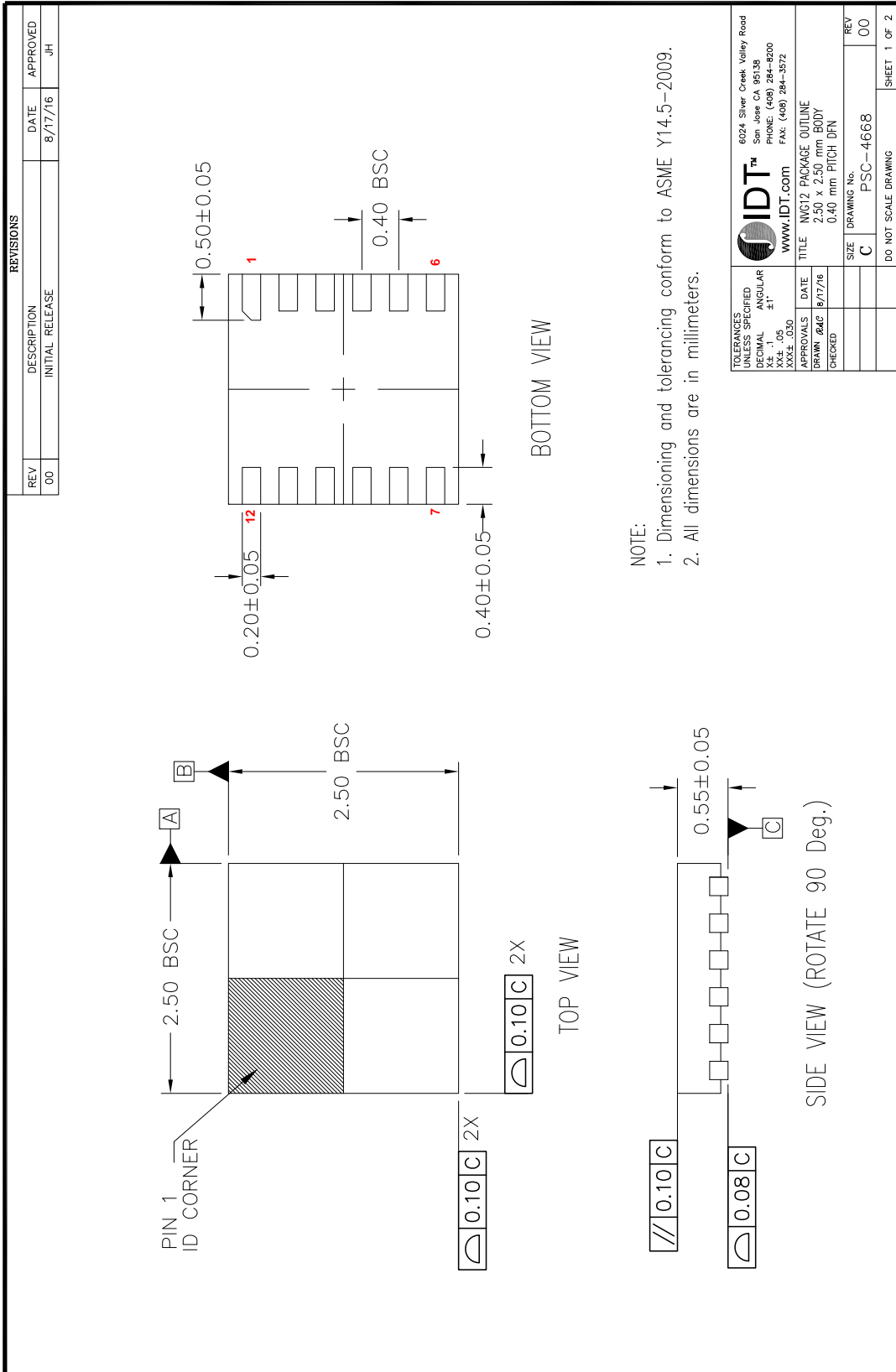
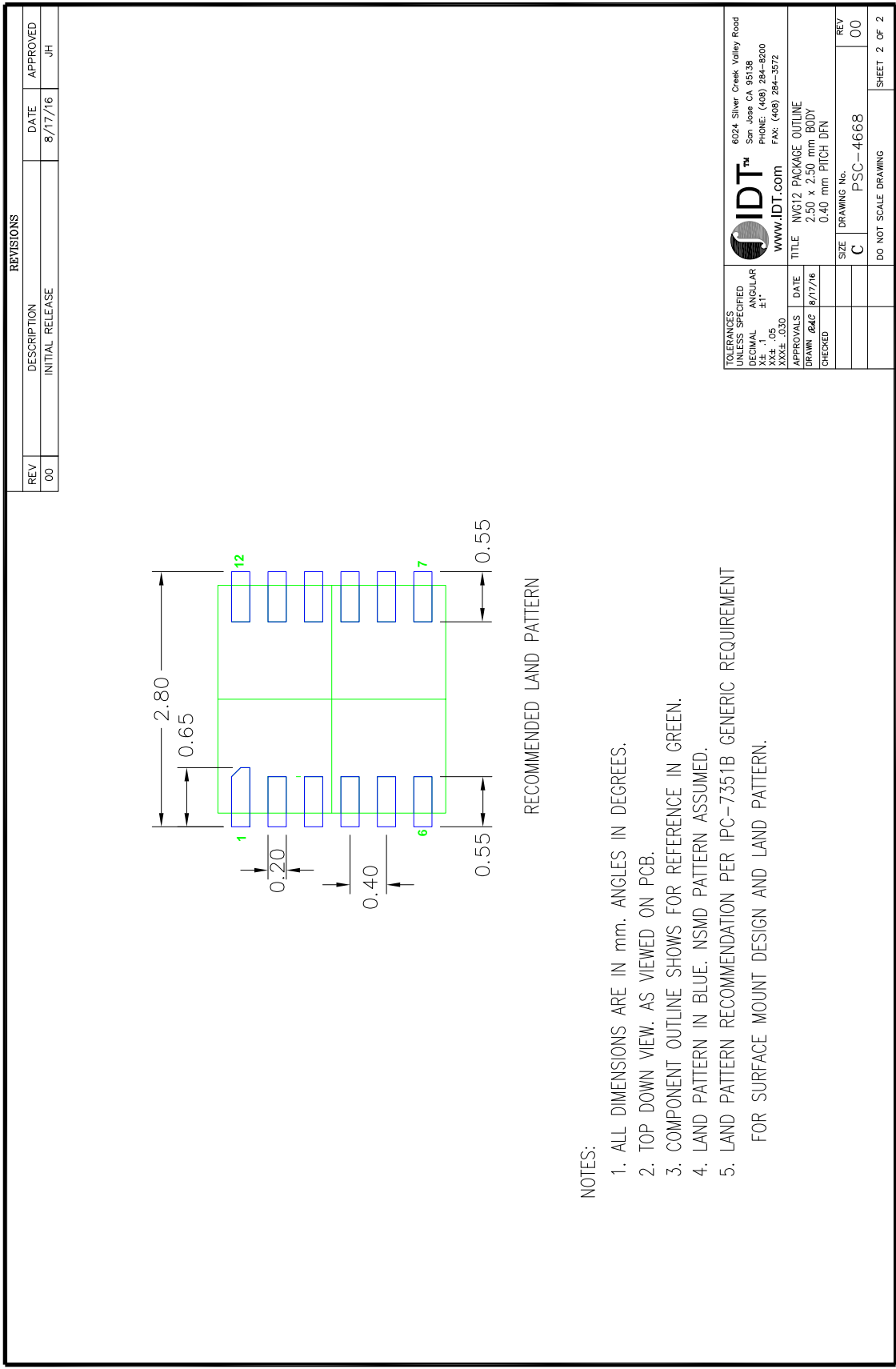
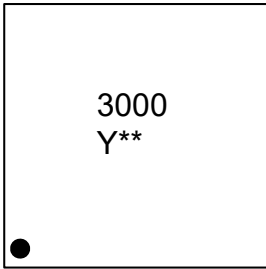

Figure 6. NVG12, 2.5 x 2.5 mm 12-DFN Package Drawing – Page 2



Marking Diagram



1. Line 1 is the truncated part number.
2. "000" denotes dash code.
3. "Y" is the last digit of the year that the part was assembled.
4. "***" denotes sequential lot number.

Ordering Information

Orderable Part Number	Package	Shipping Packaging	Temperature
5L2503-000NVGI	2.5 × 2.5 mm, 0.40mm pitch 12-DFN	Tray	-40° to +85°C
5L2503-000NVGI8	2.5 × 2.5 mm, 0.40mm pitch 12-DFN	Reel	-40° to +85°C

Revision History

Revision Date	Description of Change
October 24, 2017	Initial release.

IMPORTANT NOTICE AND DISCLAIMER

RENESAS ELECTRONICS CORPORATION AND ITS SUBSIDIARIES (“RENESAS”) PROVIDES TECHNICAL SPECIFICATIONS AND RELIABILITY DATA (INCLUDING DATASHEETS), DESIGN RESOURCES (INCLUDING REFERENCE DESIGNS), APPLICATION OR OTHER DESIGN ADVICE, WEB TOOLS, SAFETY INFORMATION, AND OTHER RESOURCES “AS IS” AND WITH ALL FAULTS, AND DISCLAIMS ALL WARRANTIES, EXPRESS OR IMPLIED, INCLUDING, WITHOUT LIMITATION, ANY IMPLIED WARRANTIES OF MERCHANTABILITY, FITNESS FOR A PARTICULAR PURPOSE, OR NON-INFRINGEMENT OF THIRD PARTY INTELLECTUAL PROPERTY RIGHTS.

These resources are intended for developers skilled in the art designing with Renesas products. You are solely responsible for (1) selecting the appropriate products for your application, (2) designing, validating, and testing your application, and (3) ensuring your application meets applicable standards, and any other safety, security, or other requirements. These resources are subject to change without notice. Renesas grants you permission to use these resources only for development of an application that uses Renesas products. Other reproduction or use of these resources is strictly prohibited. No license is granted to any other Renesas intellectual property or to any third party intellectual property. Renesas disclaims responsibility for, and you will fully indemnify Renesas and its representatives against, any claims, damages, costs, losses, or liabilities arising out of your use of these resources. Renesas' products are provided only subject to Renesas' Terms and Conditions of Sale or other applicable terms agreed to in writing. No use of any Renesas resources expands or otherwise alters any applicable warranties or warranty disclaimers for these products.

(Disclaimer Rev.1.0 Mar 2020)

Corporate Headquarters

TOYOSU FORESIA, 3-2-24 Toyosu,
Koto-ku, Tokyo 135-0061, Japan
www.renesas.com

Contact Information

For further information on a product, technology, the most up-to-date version of a document, or your nearest sales office, please visit:
www.renesas.com/contact/

Trademarks

Renesas and the Renesas logo are trademarks of Renesas Electronics Corporation. All trademarks and registered trademarks are the property of their respective owners.