

Description

The ICS558-01 accepts a high speed input of either PECL or CMOS, integrates a divider of 1, 2, 3, or 4, and provides four CMOS low skew outputs. The chip also has output enables so that one, three, or all four outputs can be tri-stated.

The ICS558-01 is a member of the IDT Clock Blocks™ family of clock generation, synchronization, and distribution devices.

Features

- 16-pin TSSOP package
- Pb (lead) free package
- Selectable PECL or CMOS inputs
- Operates up to 250 MHz
- Works as a voltage translator
- Four low skew (<250 ps) outputs
- Selectable internal divider
- Operating input voltages of 3.3 V or 5.0 V
- Operating output voltages of 2.5 V, 3.3 V or 5.0 V
- Ideal for IA64 designs

Block Diagram

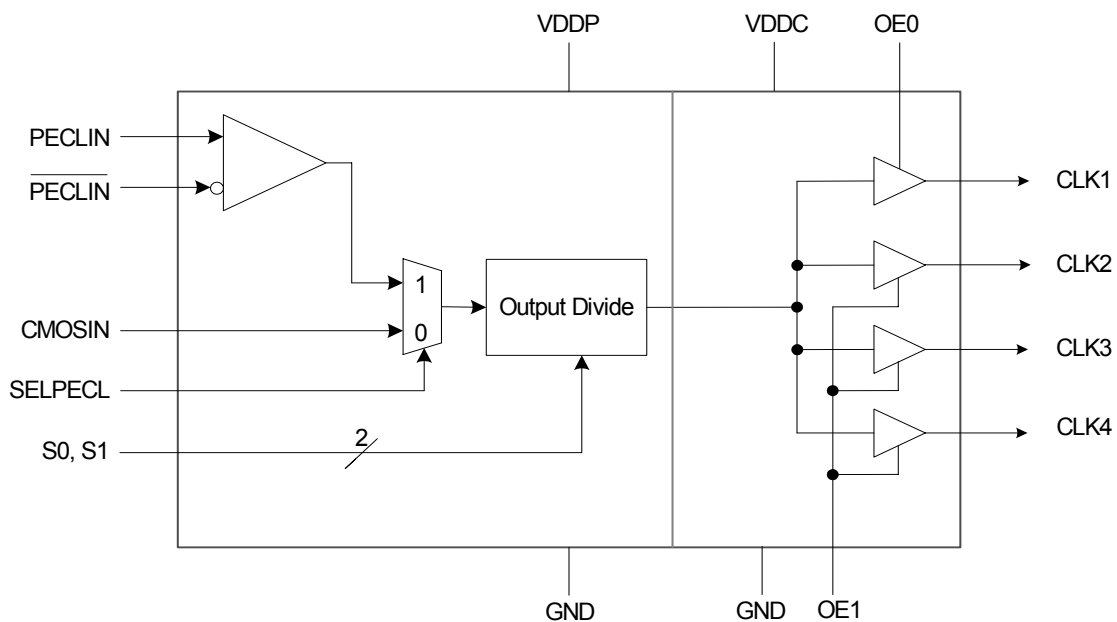

Pin Assignment

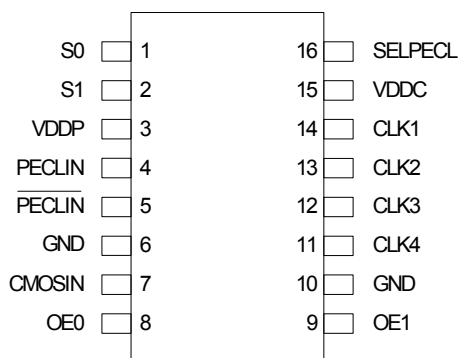

16-pin 173 Mill (0.65mm) TSSOP

Input Clock Selection

SELPECL	Input
0	CMOSIN
1	PECLIN

Tri-State Table

OE1	OE0	CLK 1	CLK 2, 3, 4
0	0	Tri-state	Tri-state
0	1	Clock ON	Tri-state
1	0	Tri-state	Clock ON
1	1	Clock ON	Clock ON

Output Divide Selection

S1	S0	Output Divide
0	0	/1
0	1	/2
1	0	/3
1	1	/4

Pin Descriptions

Pin Number	Pin Name	Pin Type	Pin Description
1	S0	Input	Select 0 for output divider. See table above. Internal pull-up to VDDP.
2	S1	Input	Select 1 for output divider. See table above. Internal pull-up to VDDP.
3	VDDP	Power	Connect to +3.3 V or +5 V. Decouple to pin 6.
4	PECLIN	Clock Input	PECL input. Connect to ground if not used.
5	$\overline{\text{PECLIN}}$	Clock Input	Complimentary PECL input. Connect to ground if not used.
6	GND	Power	Connect to ground.
7	CMOSIN	Clock Input	CMOS input. Connect to ground if not used.
8	OE0	Input	Output Enable 0. See table above. Internal pull-up to VDDP.
9	OE1	Input	Output Enable 1. See table above. Internal pull-up to VDDP.
10	GND	Power	Connect to ground.
11	CLK4	Output	Low skew clock output.
12	CLK3	Output	Low skew clock output.
13	CLK2	Output	Low skew clock output.
14	CLK1	Output	Low skew clock output.
15	VDDC	Power	Connect to +2.5 V, +3.3 V, or +5 V. Decouple to pin 10.
16	SELPECL	Input	Selects PECL or CMOS input. See table above. Internal pull-up to VDDP.

External Components

The ICS558-01 requires two 0.01 μF capacitors between VDDP and GND, and VDDC and GND—one on each side of the chip. These must be close to the chip to minimize lead inductance. Series termination resistors of 33 Ω can be used on the outputs (these also must be close to the chip).

Absolute Maximum Ratings

Stresses above the ratings listed below can cause permanent damage to the ICS558-01. These ratings, which are standard values for IDT commercially rated parts, are stress ratings only. Functional operation of the device at these or any other conditions above those indicated in the operational sections of the specifications is not implied. Exposure to absolute maximum rating conditions for extended periods can affect product reliability. Electrical parameters are guaranteed only over the recommended operating temperature range.

Item	Rating
Supply Voltage; VDDP, VDDC (referenced to ground)	7.0 V
Inputs and Clock Outputs (referenced to ground)	-0.5 V to VDD+0.5 V
Ambient Operating Temperature	0 to +70 °C
Storage Temperature	-65 to +150 °C
Soldering Temperature (maximum of 10 seconds)	260 °C

DC Electrical Characteristics

VDDP = VDDC = 3.3V (unless stated otherwise), Ambient temperature 0 to +70 °C

Parameter	Symbol	Conditions	Min.	Typ.	Max.	Units
Operating Voltage, VDDP		VDDP \geq VDDC	3.0		5.5	V
Operating Voltage, VDDC		VDDP \geq VDDC	2.375		VDDP	V
Input High Voltage, CMOSIN	V _{IH}		(VDDP/2)+ 1			V
Input Low Voltage, CMOSIN	V _{IL}				(VDDP/2)- 1	V
Input High Voltage	V _{IH}	non-clock pins	VDDP-0.5		VDDP	V
Input Low Voltage	V _{IL}	non-clock pins			0.5	V
Common Mode Range, PECLIN		VDDP=5 V	VDDP-3.7		VDDP-0.6	V
Common Mode Range, PECLIN		VDDP=3.3 V	VDDP-2.0		VDDP-0.6	V
Peak-to-Peak Input Voltage, PECLIN			0.3		1.0	V
Output High Voltage	V _{OH}	VDDC = 5 V, I _{OH} = -24 mA	VDDC-0.4			V
Output Low Voltage	V _{OL}	VDDC = 5 V, I _{OL} = 24 mA			0.4	V
Output High Voltage	V _{OH}	VDDC = 3.3 V, I _{OH} = -18 mA	VDDC-0.4			V
Output Low Voltage	V _{OL}	VDDC = 3.3 V, I _{OL} = 18 mA			0.4	V

Parameter	Symbol	Conditions	Min.	Typ.	Max.	Units
Output High Voltage	V_{OH}	VDDC = 2.5 V, $I_{OH} = -8$ mA	VDDC-0.4			V
Output Low Voltage	V_{OL}	VDDC = 2.5 V $I_{OL} = 8$ mA			0.4	V
Operating Supply Current	IDDP	No load, 100 MHz input		22		mA
Operating Supply Current	IDDC	No load, 100 MHz input		18		mA
Short Circuit Current				+70		mA
On-chip pull-up resistor	R_{PU}			250		k Ω
Input Capacitance	C_{IN}			4		pF

AC Electrical Characteristics

VDDP = VDDC = 3.3 V (unless stated otherwise), Ambient Temperature 0 to +70 °C

Parameter	Symbol	Conditions	Min.	Typ.	Max.	Units
Input Frequency			0		250	MHz
Output Rise Time	t_{OR}				800	ps
Output Fall Time	t_{OF}				750	ps
Skew, between any output clocks		(Assumes identically loaded outputs with identical rise times, measured at VDDC/2)		0	250	ps
Propagation Delay		/1		5.0		ns
		/2		6.0		ns
		/3				ns
		/4		7.0		ns
Output Clock Duty Cycle for /2 and /4			45	50	55	%
Output Clock Duty Cycle for /1 and /3			45	50	55	%

Thermal Characteristics (16-pin TSSOP)

Parameter	Symbol	Conditions	Min.	Typ.	Max.	Units
Thermal Resistance Junction to Ambient	θ_{JA}	Still air		78		°C/W
	θ_{JA}	1 m/s air flow		70		°C/W
	θ_{JA}	3 m/s air flow		68		°C/W
Thermal Resistance Junction to Case	θ_{JC}			37		°C/W

Package Outline and Package Dimensions (16-pin TSSOP, 4.40 mm Body, 0.65 mm Pitch)

Package dimensions are kept current with JEDEC Publication No. 95, MO-153

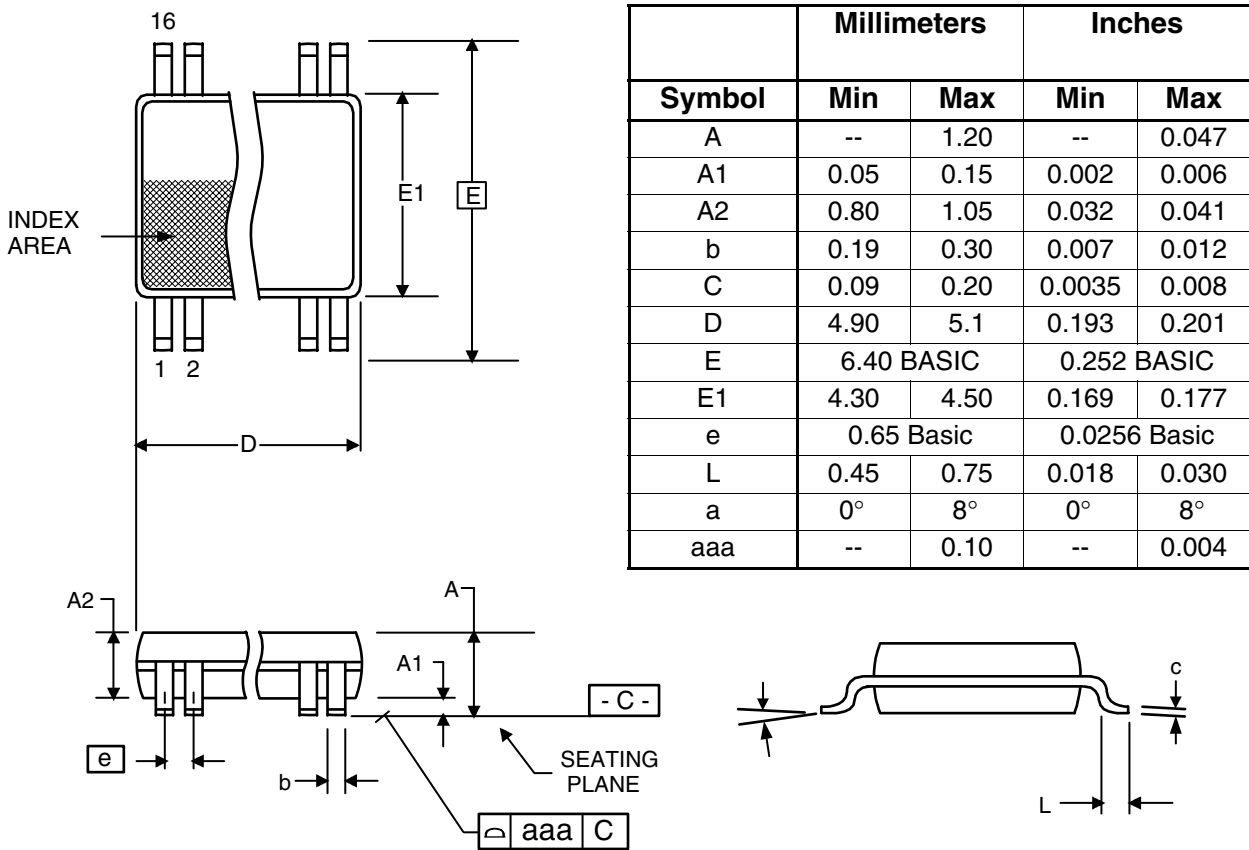

Ordering Information

Part / Order Number	Marking	Shipping Packaging	Package	Temperature
558G-01LF	558G-01LF	Tubes	16-pin TSSOP	0 to +70° C
558G-01LFT	558G-01LF	Tape and Reel	16-pin TSSOP	0 to +70° C

"LF" suffix to the part number are the Pb-Free configuration and are RoHS compliant.

While the information presented herein has been checked for both accuracy and reliability, Integrated Device Technology (IDT) assumes no responsibility for either its use or for the infringement of any patents or other rights of third parties, which would result from its use. No other circuits, patents, or licenses are implied. This product is intended for use in normal commercial applications. Any other applications such as those requiring extended temperature range, high reliability, or other extraordinary environmental requirements are not recommended without additional processing by IDT. IDT reserves the right to change any circuitry or specifications without notice. IDT does not authorize or warrant any IDT product for use in life support devices or critical medical instruments.

IMPORTANT NOTICE AND DISCLAIMER

RENESAS ELECTRONICS CORPORATION AND ITS SUBSIDIARIES (“RENESAS”) PROVIDES TECHNICAL SPECIFICATIONS AND RELIABILITY DATA (INCLUDING DATASHEETS), DESIGN RESOURCES (INCLUDING REFERENCE DESIGNS), APPLICATION OR OTHER DESIGN ADVICE, WEB TOOLS, SAFETY INFORMATION, AND OTHER RESOURCES “AS IS” AND WITH ALL FAULTS, AND DISCLAIMS ALL WARRANTIES, EXPRESS OR IMPLIED, INCLUDING, WITHOUT LIMITATION, ANY IMPLIED WARRANTIES OF MERCHANTABILITY, FITNESS FOR A PARTICULAR PURPOSE, OR NON-INFRINGEMENT OF THIRD-PARTY INTELLECTUAL PROPERTY RIGHTS.

These resources are intended for developers who are designing with Renesas products. You are solely responsible for (1) selecting the appropriate products for your application, (2) designing, validating, and testing your application, and (3) ensuring your application meets applicable standards, and any other safety, security, or other requirements. These resources are subject to change without notice. Renesas grants you permission to use these resources only to develop an application that uses Renesas products. Other reproduction or use of these resources is strictly prohibited. No license is granted to any other Renesas intellectual property or to any third-party intellectual property. Renesas disclaims responsibility for, and you will fully indemnify Renesas and its representatives against, any claims, damages, costs, losses, or liabilities arising from your use of these resources. Renesas' products are provided only subject to Renesas' Terms and Conditions of Sale or other applicable terms agreed to in writing. No use of any Renesas resources expands or otherwise alters any applicable warranties or warranty disclaimers for these products.

(Disclaimer Rev.1.01 Jan 2024)

Corporate Headquarters

TOYOSU FORESIA, 3-2-24 Toyosu,
Koto-ku, Tokyo 135-0061, Japan
www.renesas.com

Trademarks

Renesas and the Renesas logo are trademarks of Renesas Electronics Corporation. All trademarks and registered trademarks are the property of their respective owners.

Contact Information

For further information on a product, technology, the most up-to-date version of a document, or your nearest sales office, please visit www.renesas.com/contact-us/.