

Description

The ICS342 is a low cost, dual-output, field programmable clock synthesizer. The ICS342 can generate two output frequencies from 250 kHz to 200 MHz, using up to two independently configurable PLLs. The outputs may employ Spread Spectrum techniques to reduce system electro-magnetic interference (EMI).

Using IDT's VersaClock™ software to configure the PLL and output, the ICS342 contains a One-Time Programmable (OTP) ROM to allow field programmability. Programming features include 2 selectable configuration registers. Using Phase-Locked Loop (PLL) techniques, the device runs from a standard fundamental mode, inexpensive crystal, or clock. It can replace multiple crystals and oscillators, saving board space and cost.

The device also has a power down feature that tri-states the clock outputs and turns off the PLLs when the $\overline{\text{PDTS}}$ pin is taken low.

The ICS342 is also available in factory programmed custom versions for high-volume applications.

Features

- 8-pin SOIC package (Pb-free)
- Highly accurate frequency generation
 - M/N Multiplier PLL: $M = 1 \dots 2048$, $N = 1 \dots 1024$
- Output clock frequencies up to 200 MHz
- Two ROM locations for frequency and spread selection
- Spread spectrum capability for lower system EMI
 - Center or Down Spread up to 4% total
 - Selectable 32 kHz or 120 kHz modulation
- Input crystal frequency from 5 to 27 MHz
- Input clock frequency from 2 to 50 MHz
- Operating voltage of 3.3 V
- Advanced, low power CMOS process
- For one output clock, use the ICS341. For three output clocks, see the ICS343. For more than three outputs, see the ICS345 or ICS348.

Block Diagram

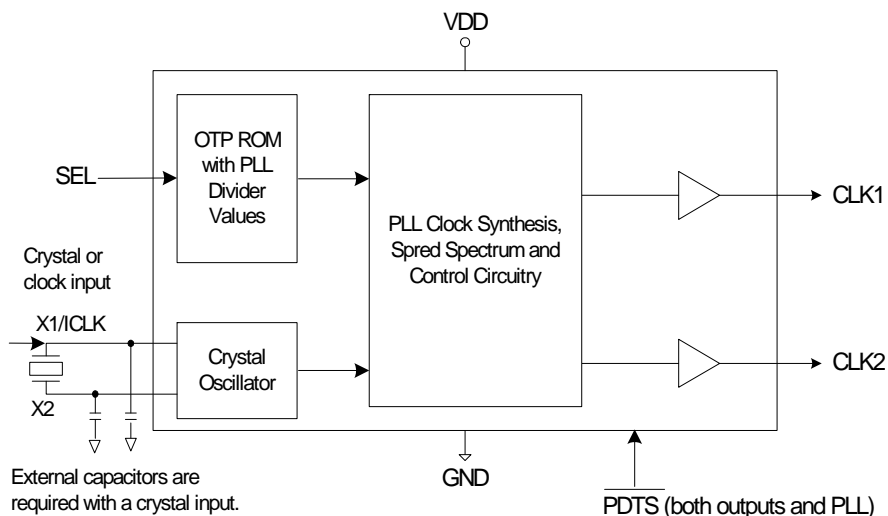

Pin Assignment

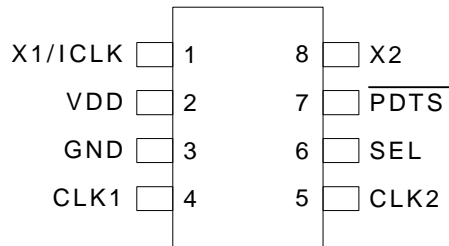

8-pin (150 mil) SOIC

Output Clock Selection Table

SEL	CLK1 (MHz)	CLK2 (MHz)	Spread Percentage
0	User Configurable	User Configurable	User Configurable
1	User Configurable	User Configurable	User Configurable

Pin Description

Pin Number	Pin Name	Pin Type	Pin Description
1	X1/ICLK	XI	Connect this pin to a crystal or external clock input.
2	VDD	Power	Connect to +3.3 V.
3	GND	Power	Connect to ground.
4	CLK1	Output	Clock output. Weak internal pull-down when tri-state.
5	CLK2	Output	Clock output. Weak internal pull-down when tri-state.
6	SEL	Input	Select for frequency selection on CLK1 and CLK2. Internal pull-up resistor.
7	P̄DTS	Input	Powers down entire chip. Tri-states CLK outputs when low. Internal pull-up resistor.
8	X2	XO	Connect this pin to a crystal, or float for clock input.

External Components

Series Termination Resistor

Clock output traces over one inch should use series termination. To series terminate a 50Ω trace (a commonly used trace impedance), place a 33Ω resistor in series with the clock line, as close to the clock output pin as possible. The nominal impedance of the clock output is 20Ω.

Decoupling Capacitor

As with any high-performance mixed-signal IC, the ICS342 must be isolated from system power supply noise to perform optimally.

A decoupling capacitor of 0.01μF must be connected between VDD and the PCB ground plane.

Crystal Load Capacitors

The device crystal connections should include pads for small capacitors from X1 to ground and from X2 to ground. These capacitors are used to adjust the stray capacitance of the board to match the nominally required crystal load capacitance. Because load capacitance can only be increased in this trimming process, it is important to keep stray capacitance to a minimum by using very short PCB traces (and no vias) between the crystal and device. Crystal

capacitors must be connected from each of the pins X1 and X2 to ground.

The value (in pF) of these crystal caps should equal $(C_L - 6 \text{ pF})^2$. In this equation, C_L = crystal load capacitance in pF. Example: For a crystal with a 16 pF load capacitance, each crystal capacitor would be 20 pF $[(16-6) \times 2] = 20$.

PCB Layout Recommendations

For optimum device performance and lowest output phase noise, the following guidelines should be observed.

1) The 0.01μF decoupling capacitor should be mounted on the component side of the board as close to the VDD pin as possible. No vias should be used between the decoupling capacitor and VDD pin. The PCB trace to VDD pin should be kept as short as possible, as should the PCB trace to the ground via. Distance of the ferrite bead and bulk decoupling from the device is less critical.

2) The external crystal should be mounted just next to the device with short traces. The X1 and X2 traces should not be routed next to each other with minimum spaces, instead they should be separated and away from other traces.

3) To minimize EMI, the 33Ω series termination resistor (if needed) should be placed close to the clock output.

4) An optimum layout is one with all components on the same side of the board, minimizing vias through other signal layers. Other signal traces should be routed away from the ICS342. This includes signal traces just underneath the device, or on layers adjacent to the ground plane layer used by the device.

ICS342 Configuration Capabilities

The architecture of the ICS342 allows the user to easily configure the device to a wide range of output frequencies, for a given input reference frequency.

The frequency multiplier PLL provides a high degree of precision. The M/N values (the multiplier/divide values available to generate the target VCO frequency) can be set within the range of M = 1 to 2048 and N = 1 to 1024.

The ICS342 also provides separate output divide values, from 2 through 20, to allow the two output clock banks to support widely differing frequency values from the same PLL.

Each output frequency can be represented as:

$$\text{OutputFreq} = \frac{\text{REFFreq}}{\text{OutputDivide}} \cdot \frac{M}{N}$$

IDT VersaClock Software

IDT applies years of PLL optimization experience into a user friendly software that accepts the user's target reference clock and output frequencies and generates the lowest jitter, lowest power configuration, with only a press of a button. The user does not need to have prior PLL experience or determine the optimal VCO frequency to support multiple output frequencies.

VersaClock software quickly evaluates accessible VCO frequencies with available output divide values and provides an easy to understand, bar code rating for the target output frequencies. The user may evaluate output accuracy, performance trade-off scenarios in seconds.

Spread Spectrum Modulation

The ICS342 utilizes frequency modulation (FM) to distribute energy over a range of frequencies. By modulating the output clock frequencies, the device effectively lowers energy across a broader range of frequencies; thus, lowering a system's electromagnetic interference (EMI). The modulation rate is the time from transitioning from a minimum frequency to a maximum frequency and then back to the minimum.

Spread Spectrum Modulation can be applied as either "center spread" or "down spread". During center spread modulation, the deviation from the target frequency is equal in the positive and negative directions. The effective average frequency is equal to the target frequency. In applications where the clock is driving a component with a maximum frequency rating, down spread should be applied. In this case, the maximum frequency, including modulation, is the target frequency. The effective average frequency is less than the target frequency.

The ICS342 operates in both center spread and down spread modes. For center spread, the frequency can be modulated between +/- 0.125% to +/-2.0%. For down spread, the frequency can be modulated between -0.25% to -4.0%.

Both output frequency banks will utilize identical spread spectrum percentage deviations and modulation rates, if a common VCO frequency can be identified.

Spread Spectrum Modulation Rate

The spread spectrum modulation frequency applied to the output clock frequency may occur at a variety of rates. For applications requiring the driving of "down-circuit" PLLs, Zero Delay Buffers, or those adhering to PCI standards, the spread spectrum modulation rate should be set to 30-33 kHz. For other applications, a 120 kHz modulation option is available.

Using VersaClock Products with an Input Clock Source

In order to ensure proper startup with an input clock rather than a crystal, the supply voltage must be within the operating range (3.3V ±10%) and the input signal must be stable and free from glitching. The input clock must provide pulses of at least 20ns, and no more than 500ns, for at least 160 clock cycles without any interruptions to the clock or power during this period. It may take up to 4ms for output frequencies to reach their target frequency values.

An alternative method is to have the $\overline{\text{PDT\textsubscript{S}}}$ pin asserted low while power supplies and clock sources stabilize. Once the power supply and input clock source are constant and within the acceptable frequency range, bring $\overline{\text{PDT\textsubscript{S}}}$ high. This approach is preferred if the clock source is derived from another PLL, or the source oscillator produces unpredictable output pulses prior to stabilization. No considerations need to be taken when using a crystal input source with VersaClock products.

Absolute Maximum Ratings

Stresses above the ratings listed below can cause permanent damage to the ICS342. These ratings, which are standard values for IDT commercially rated parts, are stress ratings only. Functional operation of the device at these or any other conditions above those indicated in the operational sections of the specifications is not implied. Exposure to absolute maximum rating conditions for extended periods can affect product reliability. Electrical parameters are guaranteed only over the recommended operating temperature range.

Parameter	Condition	Min.	Typ.	Max.	Units
Supply Voltage, VDD	Referenced to GND			7	V
Inputs	Referenced to GND	-0.5		VDD+ 0.5	V
Clock Outputs	Referenced to GND	-0.5		VDD+ 0.5	V
Storage Temperature		-65		150	°C
Soldering Temperature	Max 10 seconds			260	°C
Junction Temperature				125	°C

Recommended Operation Conditions

Parameter	Min.	Typ.	Max.	Units
Ambient Operating Temperature (ICS342M)	0		+70	°C
Ambient Operating Temperature (ICS342MI)	-40		+85	°C
Power Supply Voltage (measured in respect to GND)	+3.15	+3.3	+3.45	V
Power Supply Ramp Time			4	ms

DC Electrical Characteristics

Unless stated otherwise, $V_{DD} = 3.3V \pm 5\%$, Ambient Temperature -40 to $+85^{\circ}C$

Parameter	Symbol	Conditions	Min.	Typ.	Max.	Units
Operating Voltage	VDD		3.15	3.3	3.45	V
Operating Supply Current Input High Voltage	IDD	Configuration Dependent - See VersaClock™ Estimates				mA
		Two 33.3333 MHz outputs, PDTS = 1, no load, Note 1		13		mA
		PDTS = 0		20		μA
Input High Voltage	V _{IH}	SEL pin	2			V
Input Low Voltage	V _{IL}	SEL pin			0.4	V
Input High Voltage, \overline{PDTS}	V _{IH}		VDD-0.5			V
Input Low Voltage, \overline{PDTS}	V _{IL}				0.4	V
Input High Voltage	V _{IH}	ICLK	VDD/2+1			V
Input Low Voltage	V _{IL}	ICLK			VDD/2-1	V
Output High Voltage (CMOS High)	V _{OH}	I _{OH} = -4 mA	VDD-0.4			V
Output High Voltage	V _{OH}	I _{OH} = -12 mA	2.4			V
Output Low Voltage	V _{OL}	I _{OL} = 12mA			0.4	V
Short Circuit Current	I _{OS}			±70		mA
Nominal Output Impedance	Z _O			20		Ω
Internal pull-up resistor	R _{PUP}	SEL, \overline{PDTS} pins		250		kΩ
Internal pull-down resistor	R _{PD}	CLK output		525		kΩ
Input Capacitance	C _{IN}	Inputs		4		pF

Note 1: Example with 25 MHz crystal input with two outputs of $33.\overline{3}$ MHz, no load, and $V_{DD} = 3.3$ V.

AC Electrical Characteristics

Unless stated otherwise, $V_{DD} = 3.3V \pm 5\%$, Ambient Temperature -40 to $+85^{\circ}C$

Parameter	Symbol	Conditions	Min.	Typ.	Max.	Units
Input Frequency	F_{IN}	Fundamental Crystal	5		27	MHz
		Input Clock	2		50	MHz
Output Frequency			0.25		200	MHz
Output Rise Time	t_{OR}	20% to 80%, Note 1		1		ns
Output Fall Time	t_{OF}	80% to 20%, Note 1		1		ns
Duty Cycle		Note 2	40	49-51	60	%
Output Frequency Synthesis Error		Configuration Dependent	TBD			ppm
Power-up time		PLL lock time from power-up, Note 3		4	10	ms
		$\overline{PDT\overline{S}}$ goes high until stable CLK output, Spread Spectrum Off, Note 3		0.2	2	ms
		$\overline{PDT\overline{S}}$ goes high until stable CLK output, Spread Spectrum On, Note 3		4	7	ms
One Sigma Clock Period Jitter		Configuration Dependent		50		ps
Maximum Absolute Jitter	t_{ja}	Deviation from Mean. Configuration Dependent		± 200		ps

Note 1: Measured with 15 pF load.

Note 2: Duty Cycle is configuration dependent. Most configurations are minimum 45% and maximum 55%.

Note 3: IDT test mode output occurs for first 170 clock cycles on CLK2 for each PLL powered up. $\overline{PDT\overline{S}}$ transition high on select address change.

Thermal Characteristics

Parameter	Symbol	Conditions	Min.	Typ.	Max.	Units
Thermal Resistance Junction to Ambient	θ_{JA}	Still air		150		$^{\circ}C/W$
	θ_{JA}	1 m/s air flow		140		$^{\circ}C/W$
	θ_{JA}	3 m/s air flow		120		$^{\circ}C/W$
Thermal Resistance Junction to Case	θ_{JC}			40		$^{\circ}C/W$

Package Outline and Package Dimensions (8-pin SOIC, 150 Mil. Body)

Package dimensions are kept current with JEDEC Publication No. 95

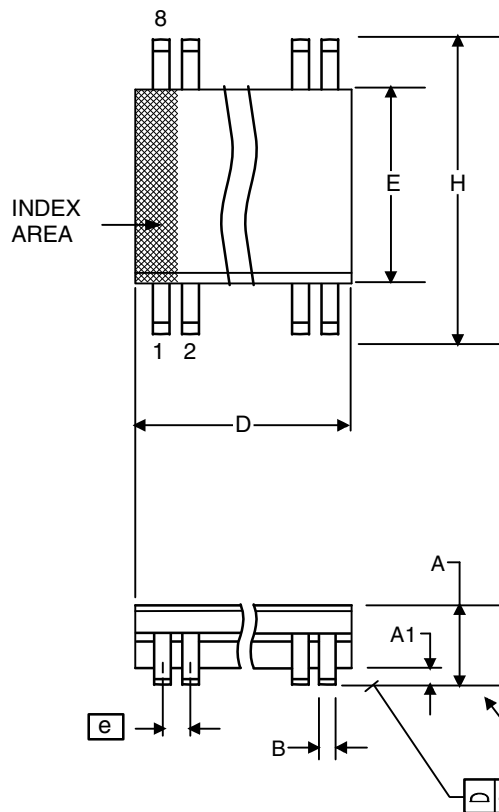

Symbol	Millimeters		Inches	
	Min	Max	Min	Max
A	1.35	1.75	.0532	.0688
A1	0.10	0.25	.0040	.0098
B	0.33	0.51	.013	.020
C	0.19	0.25	.0075	.0098
D	4.80	5.00	.1890	.1968
E	3.80	4.00	.1497	.1574
e	1.27 BASIC		0.050 BASIC	
H	5.80	6.20	.2284	.2440
h	0.25	0.50	.010	.020
L	0.40	1.27	.016	.050
α	0°	8°	0°	8°

Ordering Information

Part / Order Number	Marking	Shipping Packaging	Package	Temperature
342MPLF	342MPLF	Tubes	8-pin SOIC	0 to +70° C
342MPLFT	342MPLF	Tape and Reel	8-pin SOIC	0 to +70° C
342MIPLF	342MIPLF	Tubes	8-pin SOIC	-40 to +85° C
342MIPLFT	342MIPLF	Tape and Reel	8-pin SOIC	-40 to +85° C
342M-XXLF	342MXXLF	Tubes	8-pin SOIC	0 to +70° C
342M-XXLFT	342MXXLF	Tape and Reel	8-pin SOIC	0 to +70° C
342MI-XXLF	342MIXXL	Tubes	8-pin SOIC	-40 to +85° C
342MI-XXLFT	342MIXXL	Tape and Reel	8-pin SOIC	-40 to +85° C

"LF" suffix to the part number denotes Pb-Free configuration, RoHS compliant.

The 342M-XXLF and 342MI-XXLF are factory programmed versions of the 342MPLF and 342MIPLF. A unique "-XX" suffix is assigned by the factory for each custom configuration, and a separate data sheet is kept on file. For more information on custom part numbers programmed at the factory, please contact your local IDT sales and marketing representative.

While the information presented herein has been checked for both accuracy and reliability, IDT assumes no responsibility for either its use or for the infringement of any patents or other rights of third parties, which would result from its use. No other circuits, patents, or licenses are implied. This product is intended for use in normal commercial applications. Any other applications such as those requiring extended temperature range, high reliability, or other extraordinary environmental requirements are not recommended without additional processing by IDT. IDT reserves the right to change any circuitry or specifications without notice. ICS does not authorize or warrant any IDT product for use in life support devices or critical medical instruments.

Revision History

Rev.	Date	Originator	Description of Change
N	09/06/13	S. Zheng	Added brief applications section/verbiage "Using VersaClock Products with an Input Clock Source" on page 3.

ICS342

FIELD PROGRAMMABLE DUAL OUTPUT SS VERSACLOCK SYNTHESIZER

EPROM CLOCK SYNTHESIZER

IMPORTANT NOTICE AND DISCLAIMER

RENESAS ELECTRONICS CORPORATION AND ITS SUBSIDIARIES (“RENESAS”) PROVIDES TECHNICAL SPECIFICATIONS AND RELIABILITY DATA (INCLUDING DATASHEETS), DESIGN RESOURCES (INCLUDING REFERENCE DESIGNS), APPLICATION OR OTHER DESIGN ADVICE, WEB TOOLS, SAFETY INFORMATION, AND OTHER RESOURCES “AS IS” AND WITH ALL FAULTS, AND DISCLAIMS ALL WARRANTIES, EXPRESS OR IMPLIED, INCLUDING, WITHOUT LIMITATION, ANY IMPLIED WARRANTIES OF MERCHANTABILITY, FITNESS FOR A PARTICULAR PURPOSE, OR NON-INFRINGEMENT OF THIRD PARTY INTELLECTUAL PROPERTY RIGHTS.

These resources are intended for developers skilled in the art designing with Renesas products. You are solely responsible for (1) selecting the appropriate products for your application, (2) designing, validating, and testing your application, and (3) ensuring your application meets applicable standards, and any other safety, security, or other requirements. These resources are subject to change without notice. Renesas grants you permission to use these resources only for development of an application that uses Renesas products. Other reproduction or use of these resources is strictly prohibited. No license is granted to any other Renesas intellectual property or to any third party intellectual property. Renesas disclaims responsibility for, and you will fully indemnify Renesas and its representatives against, any claims, damages, costs, losses, or liabilities arising out of your use of these resources. Renesas' products are provided only subject to Renesas' Terms and Conditions of Sale or other applicable terms agreed to in writing. No use of any Renesas resources expands or otherwise alters any applicable warranties or warranty disclaimers for these products.

(Rev.1.0 Mar 2020)

Corporate Headquarters

TOYOSU FORESIA, 3-2-24 Toyosu,
Koto-ku, Tokyo 135-0061, Japan
www.renesas.com

Contact Information

For further information on a product, technology, the most up-to-date version of a document, or your nearest sales office, please visit:
www.renesas.com/contact/

Trademarks

Renesas and the Renesas logo are trademarks of Renesas Electronics Corporation. All trademarks and registered trademarks are the property of their respective owners.