

Integrated Approach to Wireless Charging Technology

Technology Gives Mobile Devices a Boost

Wireless Power technology is on the rise; in the last few years, many proprietary after-market solutions have become available for a variety of mobile devices. Industry as a whole recognized the need for a wireless power standard and adopted 'Qi' [pronounced Chee] as a universal standard to enforce common protocol and inter-operability through Wireless Power Consortium (WPC).

By Manjit Singh, Integrated Device Technology

We are beginning to see some wireless power charging pads becoming available in the market, but due to the complexity of their design, they are being sold at retail price close to \$100 US. To date, this has been cost prohibitive to major carriers such as AT&T, Verizon, and Sprint, and to OEMs that include Samsung, LG and Nokia. Such complexity and the resultant higher cost of wireless power transmitters dis-incentivized carriers and OEMs from including a charging pad as a standard 'in-box' accessory. Instead, an after-market product approach has been taken and the pricing point of the charging pad isn't very attractive to the end user. This article covers some guidelines and tips for engineers designing a WPC compliant wireless power transmitter that is cost competitive and low in terms of complexity.

Introduction

In today's age of infotainment, portable mobile devices such as smart phones, tablets and eBook readers, are using the stored energy in their batteries at such high rates that recharging the battery in middle of the day has become a necessity, not an option. Gone are the days when a mobile device, when fully charged, could operate for several days. User demand for audio & Video streaming, high definition gaming, GPS, and frequent web browsing, means that energy usage has outpaced the small advancements made in increasing battery energy density over the past few years.

Carrying around AC adaptors is impractical and inconvenient. As useful as they are, AC adaptors are bulky and they often come with proprietary connector types. The proliferation of mobile technology means for example a typical family of four may carry, on average, about seven mobile devices for a domestic flight. As such, carrying seven different AC adaptors is a significant burden. Not to mention the issues involved in dealing with different voltage ratings and connectors for different countries or regions. Finally, it has to be said that the aesthetics of AC adaptors are not ideal and do not complement the highly stylized portable devices they are designed for.

Wireless Power Charging, as a technology based on induction, is not a new concept; in fact it fascinated Nikola Tesla (1856 – 1943) in his heyday! What is new today is the need for wireless power charging for mobile devices whose battery size and capacity isn't keeping up with the use-model of the battery. While end-users take their lunch break, it makes sense, and is almost a necessity, that their mobile

device 'power snacks' wirelessly too. This has not happened yet because the cost of the wireless power transmitter has been prohibitive for both OEMs and infrastructure vendors. Because of the high cost of constructing a transmitter, carriers and OEMs have had to price a charging pad at around \$80 to \$100 US. This is largely due to the IC solutions currently available on the market; a typical wireless power transmitter using the available technology consists of nine ICs and more than 80 passive components.

Wireless Power Charging System

A typical wireless power charging system consists of a transmitter and receiver that are coupled inductively through two sets of coils as shown in Figure 1.



Figure 1: A wireless power charging system using IDT's IDTP9030 and IDTP9020 devices

On the transmitter side, an inverter (half-bridge in the example) converts a DC input voltage into an AC current signal. A changing AC current in the transmitter coil induces a voltage in the receiver coil following Faraday's law of induction and Biot-Savart's law.

Biot-Savart's Law dictates the amount of magnetic field generated by the transmitter coil current at a given distance or coupling; Whereas Faraday's law dictates the induced voltage on the receiver coil due time varying flux resulting from magnetic field of the transmitter coil.

The net result is that the incoming AC signal is converted into DC by a synchronous full-bridge rectifier on receiver as a loosely regulated rectified voltage. Further, this rectified voltage is converted into a tightly regulated DC voltage through a DC-DC stage (an LDO or a switching regulator).

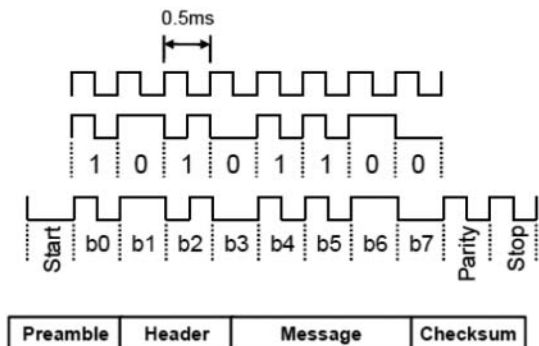

Figure 2: WPC protocol

Communication link (from RX to TX)

In the WPC communication protocol, the receiver sends communication packets through a back-scatter modulation method. The receiver modulates the load seen by the transmitter through reflected impedance to send communication bits over the same power link that exists between the two coils. A 2 KHz digital communication signal on the receiver side translates into a primary coil current/voltage having the same envelope.

Communication throughput per the WPC protocol is 2Kbps and it utilizes a differential Bi-Phase encoding scheme. Each packet has a

structure and format to it (Preamble, Header, Message, and Checksum):

Pre-amble: A stream of 1's condition the transmitter and allow it to start detecting communication packets coming from the receiver.

Header: Indicates what type of packet is the current packet and what the payload/message that is to follow after this.

Message: The actual payload/message of the packet. The size of the message is a function of the type of packet.

Checksum: At the end of each packet, the checksum byte allows the transmitter to detect errors in the packet just received.

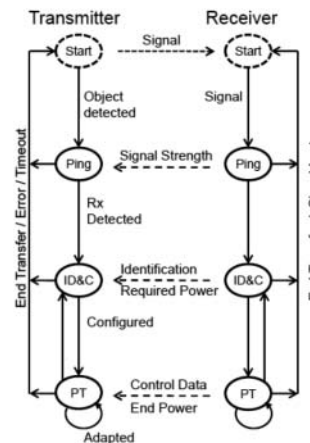

Figure 3: Control Protocol

100% of our sensors could be customized?

Absolutely.



In our changing and complex world, ABB is fully committed to support permanent improvements. That's why ABB anticipates our customers needs with different advantageous technical solution by developing sensors, keeping always in mind the best compromise between performance and cost. In order to offer customized solutions, we combine our engineering know-how with the R&D department of our customers. You have a dedicated application, we have a dedicated range. www.abb.com



Booth 11-201

ABB France
Current & Voltage Sensors Departement
e-mail: sensors.sales@fr.abb.com

Power and productivity
for a better world™



Coil Winding, Insulation and Electrical
Manufacturing Exhibition & Conference

CWIEME Berlin 2012

Messe Berlin, Berlin, Germany
26th - 28th June 2012

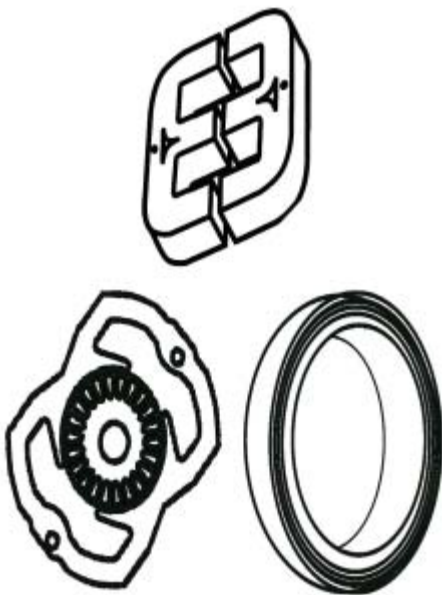

Claim your stand space
before someone else does



UK Office: PO BOX 7683,
Sturminster Newton, Dorset, DT10 9BF, UK
Telephone: +44 (0) 1258 446280 Fax: +44 (0) 1258 446355
Email: tickets@coilwinding.e7even.com

www.coilwindingexpo.com

Control Protocol

WPC has a control protocol that has four phases: Selection, Ping, ID & Configuration, and Power Transfer.

Each phase has certain required packets that the receiver must send to the transmitter to continue the power transfer. Some of the packets involved in each phase are shown in the table 1.

Header*	Packet Types	Message Size
<i>ping phase</i>		
0x01	Signal Strength	1
0x02	End Power Transfer	1
<i>identification & configuration phase</i>		
0x06	Power Control Hold-off	1
0x51	Configuration	5
0x71	Identification	7
0x81	Extended Identification	8
<i>power transfer phase</i>		
0x02	End Power Transfer	1
0x03	Control Error	1
0x04	Rectified Power	1
0x05	Charge Status	1

Table 1: Packets involved in each phase

Signal Strength Packet: Is the very first packet a receiver is required to send to indicate to the transmitter not to remove power signal. It also indicates the relative strength of the signal received by the receiver. Received signal strength can be a power, voltage, current or combination of these.

ID and Configuration Packet: Is the second packet the receiver sends to identify itself in terms of class of receiver, configuration information, any additional proprietary or optional packets to follow etc.

Control Error Packet: In power transfer state, the receiver conveys to the transmitter its power needs via control error packets. The value is a signed integer between -128 to +127. Negative values instruct the transmitter to 'decrease' the power whereas positive control error value indicates 'increase' the power.

Rectified Power Packet: In power transfer state, receiver conveys the amount of power it is delivering to the load from rectifier via this packet. It is an unsigned integer value between 0 and 100. A 0 rectified power value implies receiver isn't providing any power to the downstream load whereas 100 implies receiver is delivering full power the load.

Designing a wireless power transmitter using IDTP9030

Integrated Device Technology's IDTP9030 is the world's first single chip solution for wireless power transmitter. It seeks to offer a low cost solution with the highest level of integration. It integrates several value-add features such as Foreign Object Detection (FOD), two-way communication, and multi-mode operation. The IDTP9030, plus a few additional passive components, allows the construction of a fully functional wireless power transmitter. The IDTP9030 has a high efficiency half bridge inverter to do DC-AC conversion of input DC voltage into AC coil current. It also has an on-board modulator/demodulator block that detects, demodulates, and decodes WPC compliant communication packets. There is an embedded micro controller with RAM/ROM that executes incoming decoded packets and adjusts the operating point to adjust transmitted power to the receiver.

When configured in dual mode operation, the IDTP9030 automatically detects the type of receiver (WPC or proprietary) and adjusts its behavior based on the protocol used by the receiver.

TX-A1: 'Magnetically Guided' type transmitter Comparison

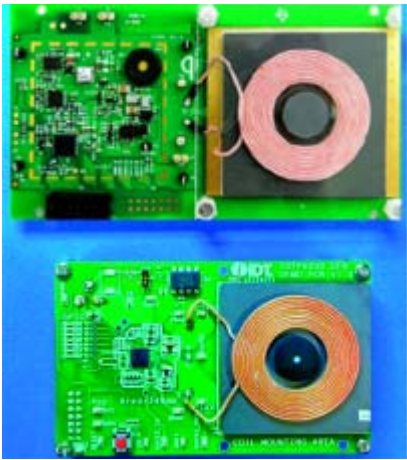

Figure 4: Typical evaluation kit (top) and one from IDT (bottom)

A typical TX-A1 transmitter manufactured with currently available ICs can be a very complex and expensive solution. Shown in Figure 4 is a comparative example between a typical evaluation kit (top) and one from IDT (bottom).

A fully functional IDTP9030 based TX-A1 type transmitter can be constructed with 30 components, including a single IC. In comparison, the same transmitter from the other evaluation board requires 90 components including five ICs. Utilizing a highly integrated transmitter IC translates to a much simpler finished design which is lower cost, has a significantly smaller footprint, and lower complexity.

This type of approach will enable carriers and their OEMs to introduce wireless charging to their end customers at lower cost and as sleek charging pads. Moreover, an ultra low cost transmitter incentivizes infrastructure vendors to rapidly design and deploy wireless charging pads into consumer end products such as furniture, tables, night lamps, and docking stations.

www.idt.com

Industry's First!

Optically Coupled I²C Bus Repeater

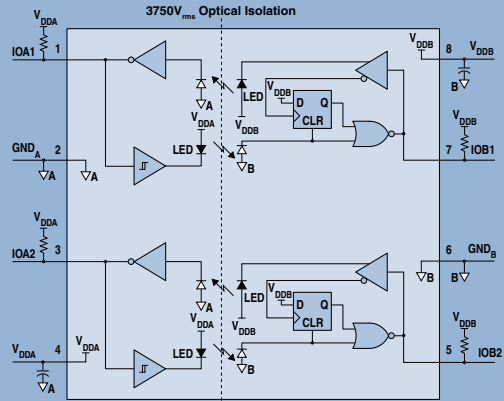

CPC5902 I²C Bus Repeater:

- Low EM and RF Generation - **No Internal Clock**
- **Bidirectionally** Buffers Both I²C Signals
- Extends and Isolates I²C Interfaces
- Supports Standard and Fast Mode I²C (400kbps)
- Isolates DC Logic Levels **No Refresh Required**
- Operates on 2.7V to 5.5V
- Glitch-Free Operation
- Translates Voltage Levels
- Immune to External EMI and RFI
- HV Isolation - Tested Above 6kV_{pk}

CPC5902 Applications:

- Power-over-Ethernet
- Power Supply High Side Interface
- Isolated Signal Monitoring and Control
- Medical Equipment
- Instrumentation
- Lighting Controls
- Motor Controls



Booth 12-401



78 Cherry Hill Drive
Beverly, MA 01915
978-524-6768

www.clare.com



www.clare.com/Products/OptBusRepBiDi.htm

TOSHIBA
Leading Innovation >>>



NUREMBERG: 8-10.5.2012, HALL 12, STAND 301

TOSHIBA DT MOS IV SUPER JUNCTION POWER MOSFETS: CHIPS WITH OPTIMISED RDS(on) x Qg AND MORE PACKAGE OPTIONS AVAILABLE

The latest generation of Toshiba's innovative family of DT MOS power MOSFETs is now available with a V_{ds} rating of 600V. The DT MOS IV makes your solutions more efficient, with easily controlled switching speed, achieved by optimising RDS(on) x Qg performance, enabling a more effective application design.

Our compact smart isolation TO-220SIS package with copper connector instead of standard wire bonds, along with the high-performance TO-3P(N) package, form the basis for the devices available, followed by TO-220 and the compact SMD DPAK package. Other compact package options will be available in the future.

Visit us today at www.toshiba-components.com/power



SCAN ME