

## Contents

1	Introduction.....	2
2	Buck Converter Operation.....	2
3	LED Current Ripple .....	4
4	Switching Frequency.....	4
5	Dimming Capability .....	5
6	Efficiency.....	5
7	AC Operation.....	6
8	Application Examples.....	7
9	Document Revision History .....	13

## List of Figures

Figure 2.1	Buck Converter LED Driver Circuit using ZLED7000 or ZLED7020 .....	2
Figure 2.2	Converter Current Wave Shapes.....	3
Figure 7.1	AC Operation of the ZLED7000 or ZLED7020 .....	6

## List of Tables

Table 8.1	Example BOM for ZLED7000 with DC Supply – High Efficiency with $I_{LED} = 150\text{ mA}$ .....	7
Table 8.2	Example BOM for ZLED7000 with DC Supply – High Frequency with $I_{LED} = 150\text{ mA}$ .....	8
Table 8.3	Example BOM for ZLED7000 with DC Supply – High Efficiency with $I_{LED} = 400\text{ mA}$ .....	8
Table 8.4	Example BOM for ZLED7000 with DC Supply – High Frequency with $I_{LED} = 400\text{ mA}$ .....	9
Table 8.5	Example BOM for ZLED7000/ZLED7020 with DC Supply – High Efficiency with $I_{LED} = 700\text{ mA}$ .....	9
Table 8.6	Example BOM for ZLED7000/ZLED7020 with DC Supply – High Frequency with $I_{LED} = 700\text{ mA}$ .....	10
Table 8.7	Example BOM for ZLED7020 with DC Supply – High Efficiency with $I_{LED} = 1\text{ A}$ .....	11
Table 8.8	Example BOM for ZLED7020 with DC Supply – High Frequency with $I_{LED} = 1\text{ A}$ .....	11
Table 8.9	Shunt Resistor Selection .....	12

## 1 Introduction

The ZLED7000 and ZLED7020 are controller ICs designed for building DC-DC converters with very few external components, especially suitable for driving LED loads with high efficiency from a DC voltage up to 40 V or a rectified AC voltage up to 28 V (if sinusoidal). The main difference between the two devices is the on-resistance and therefore the current capability of their internal power switches. The ZLED7000 is suitable for LED currents up to 700 mA, the ZLED7020 for currents up to 1.2 A. Both devices are available in a small SOT89-5 package with exposed die pad, enabling low thermal resistance from junction to ambient temperature.

## 2 Buck Converter Operation

Figure 2.1 shows a complete application circuit using the ZLED7000 or ZLED7020 in a buck converter with current control. This is the simplest way to control LEDs from a supply voltage that is higher than the forward voltage of the LED string while achieving high efficiency. When the internal switching MOSFET is turned on, current flows through shunt resistor Rshunt, the LED string, and the inductor L1, increasing almost linearly over time. When the MOSFET is switched off, the inductance drives current in the same direction, across free wheel diode D1, Rshunt, and the LED string, circulating in the free wheel loop while current decays, again almost linearly over time.

**Figure 2.1 Buck Converter LED Driver Circuit using ZLED7000 or ZLED7020**

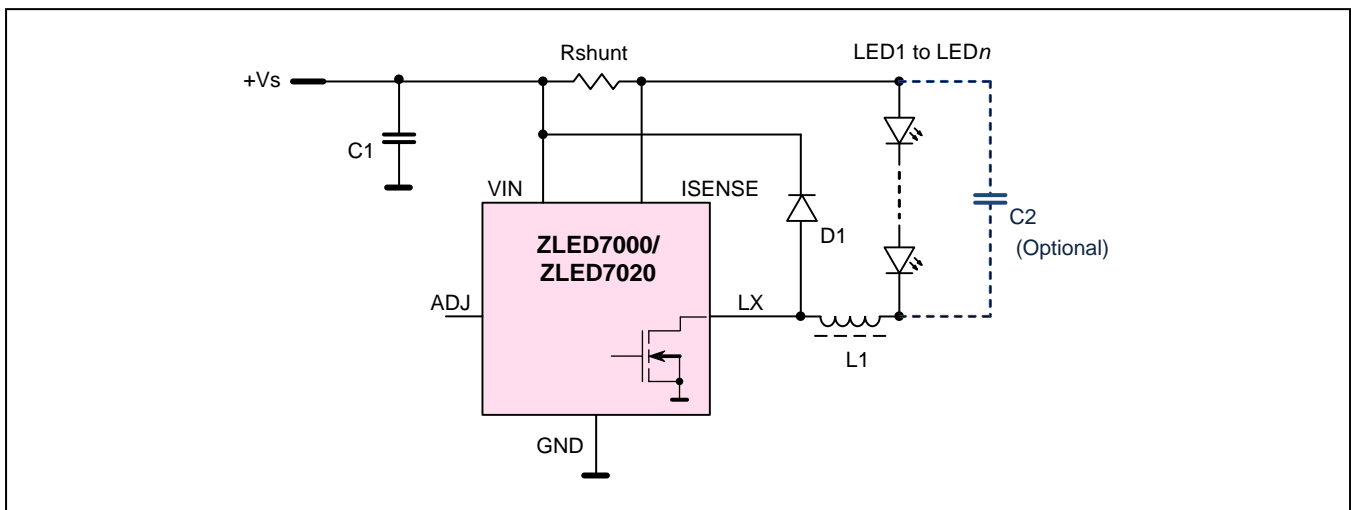

The current levels for the power transistor to turn on and off are determined by the voltage drop across Rshunt. An internal hysteresis comparator detects this voltage with an initial threshold of 95 mV (typical) with a symmetrical  $\pm 15\%$  hysteresis. The average LED current is defined as

$$I_{LEDave} = \frac{95mV}{Rshunt} \tag{1}$$

The total hysteresis is 30% of the average.

Using a high-side shunt resistor with a hysteresis comparator provides two advantages:

1. This “bang-bang” controller is fully short-circuit protected since the switching duty cycle can cover the full range from 0 to 100%.
2. Transient switching currents of the power transistor from the gate drive and drain discharge do not cause a voltage drop across the shunt resistor; consequently the blanking time after switching can be made very short and the switching frequency can be high.

Figure 2.2 shows the current waveform in the inductor L1 (and the shunt resistor Rshunt) for normal operation and for the output short-circuit condition. As long as the LED string’s forward voltage  $V_{LED}$  is significantly higher than the forward voltage of the free wheel diode D1, the switching duty cycle can be approximated by

$$d = \frac{t_{ON}}{(t_{ON} + t_{OFF})} \approx \frac{V_{LED}}{V_s} \tag{2}$$

When the output is shorted ( $V_{LED} = 0$  V), the off-time  $t_{OFF}$  is only defined by the voltage drop across D1 and the resistance of L1. In any case, the transistor will not switch on again unless the current has dropped to the lower hysteresis threshold.

**Figure 2.2 Converter Current Wave Shapes**

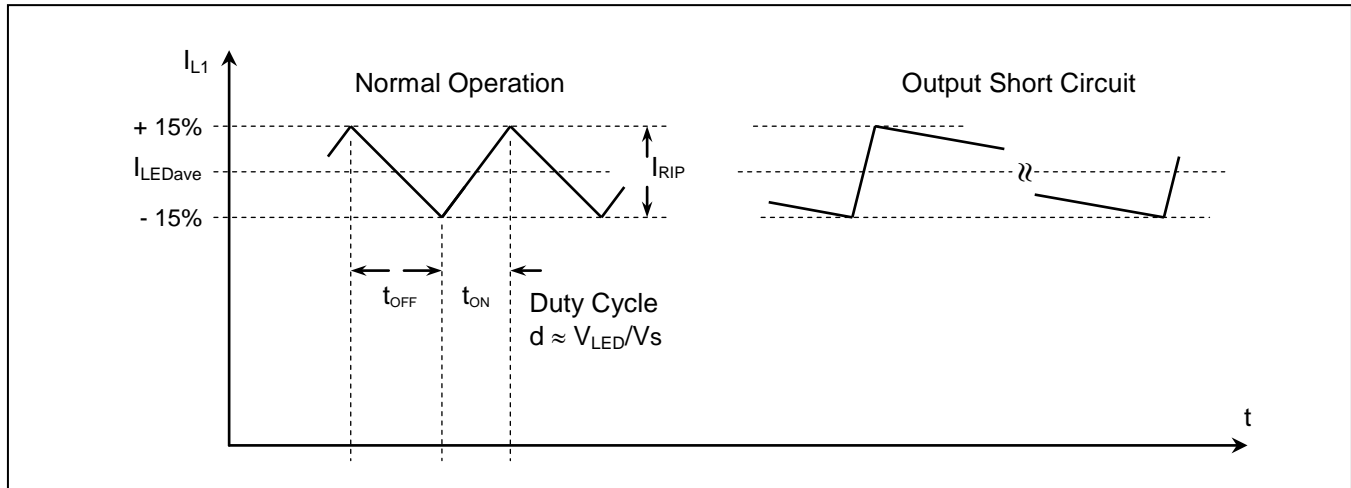

### 3 LED Current Ripple

Without any additional measures, the LEDs see a current ripple of 30% of the average current. Since power LEDs may be relatively sensitive even to periodic over-current, a capacitor C2 in parallel with the LED string is recommended, especially when the LEDs are operated near their maximum current. C2 can be estimated by

$$C2 = \frac{1}{(2\pi * f_R * n * R_{LEDdiff})} \quad (3)$$

where  $f_R$  is the same fraction of  $f_{LX}$  by which the current ripple of the LEDs should be reduced,  $R_{LEDdiff}$  is the differential resistance of a single LED at the operating current, and  $n$  is the number of LEDs in the string.

Example:

$$f_{LX} = 500 \text{ kHz}$$

Reduction of ripple current by a factor of 5 (30%  $\Rightarrow$  6%):  $f_R = f_{LX}/5 = 100 \text{ kHz}$

$n = 4$  LEDs in series

Differential resistance of a 1 W LED at 350 mA:  $R_{LEDdiff} = 1.5 \Omega$  (taken from the LED's data sheet as the tangent to the I(V) characteristic at the operating point)

To calculate the value for the C2 capacitor,

$$C2 \geq \frac{1}{(2\pi * 100\text{kHz} * 4 * 1.5\Omega)} = 265\text{nF} \quad (4)$$

Therefore, choose the standard 330 nF value for C2.

### 4 Switching Frequency

The switching frequency  $f_{LX}$  is determined by  $V_s$ ,  $V_{LED}$ ,  $I_{LEDave}$ , and  $L1$ . It can be approximated with equation (5):

$$f_{LX} = \frac{1}{(t_{ON} + t_{OFF})} \approx V_{LED} * \left( \frac{1 - \frac{V_{LED}}{V_s}}{0.3 * I_{LEDave} * L1} \right) \quad (5)$$

Actually  $f_{LX}$  is slightly lower, since equation (5) neglects voltage drops across D1 and the resistances of L1 and the internal switching transistor, but it is a reasonable approximation for getting started.

Assuming that for a given application  $V_s$ ,  $V_{LED}$ , and  $I_{LEDave}$  are pre-defined, it can be seen from equation (5) that  $f_{LX}$  is proportional to  $1/L1$ , or in other words, that a small inductance automatically results in a high switching frequency.

## 5 Dimming Capability

ZLED7000 and ZLED7020 feature two dimming modes that can be addressed via the ADJ input pin: linear dimming and PWM dimming. If left open, ADJ is internally pulled high by a 500 k $\Omega$  resistor to a voltage of approximately 1.6 V. A voltage divider with a ratio of 0.079 derives the threshold for the hysteresis comparator from the voltage on the ADJ pin. Its input is limited to 1.2 V, which means that any voltage > 1.2 V on ADJ leads to the maximum threshold of 95 mV. Providing an external voltage < 1.2 V reduces the comparator threshold accordingly. When the input voltage drops below 200 mV (typical), the output is switched off completely; above 250 mV (typical), it is turned on again (i.e., 50 mV hysteresis).

By applying a voltage between 300 mV and 1.2 V, analog dimming can be achieved in a range of 25% to 100% of the nominal current. By periodically pulling ADJ to ground or applying a digital signal to the input, PWM brightness control of the LEDs is possible. There is no specified limitation for the PWM frequency, but it should be at least 200 Hz to avoid flickering and should not exceed 10% of  $f_{LX}$  to avoid interference.

## 6 Efficiency

Efficiency is an important issue for LED drivers, and unfortunately it requires trade-offs. The ZLED7000 and ZLED7020 offer excellent features such as low operating current consumption, low switching transistor on-resistance, and fast switching to achieve high efficiency, but there are other factors that also influence this important parameter.

Static losses are caused primarily by the inductor L1 (since it conducts current continuously) and by the forward voltage of the free wheel diode D1. Losses also result from the DC resistance of the power switch. Therefore it is important to keep the RDC of L1 low as well as the  $V_f$  of D1; therefore using a Schottky diode rather than a basic silicon diode is recommended.

Dynamic losses result from the switching losses of the power transistor, reverse recovery of D1, ferrite core magnetizing of L1, and ESR (equivalent series resistance) of the bypass capacitor C1. Again, a Schottky diode is the best choice for D1. Core material and flux density of L1 must be selected properly, and C1 must be a low-ESR type capacitor.

Dynamic losses are proportional to the switching frequency  $f_{LX}$ , which means that a lower frequency can improve efficiency. On the other hand, a lower  $f_{LX}$  requires a bulkier inductor L1.

## 7 AC Operation

For operation from an AC source, a rectifier, preferably a bridge rectifier, is required as shown in Figure 7.1. If using a 50/60 Hz supply from a line voltage transformer (e.g., 12 VAC transformer for halogen lamps), an electrolytic bypass capacitor C1a is necessary to maintain the supply voltage higher than the LED string voltage for the time the AC voltage is below the LED string voltage. A ceramic capacitor C1b is recommended to absorb the switching transients. If supplied from an electronic ballast with a typical switching frequency in the range of 30 kHz to 80 kHz, the electrolytic capacitor might not be necessary; however, it depends on the type of ballast since some devices operate in this frequency range but with an output that is similar to a carrier frequency with the line power frequency as an envelope. Please note that not all electronic ballasts are able to operate non-resistive loads such as DC-DC converters with a rectifier in the supply.

**Figure 7.1 AC Operation of the ZLED7000 or ZLED7020**

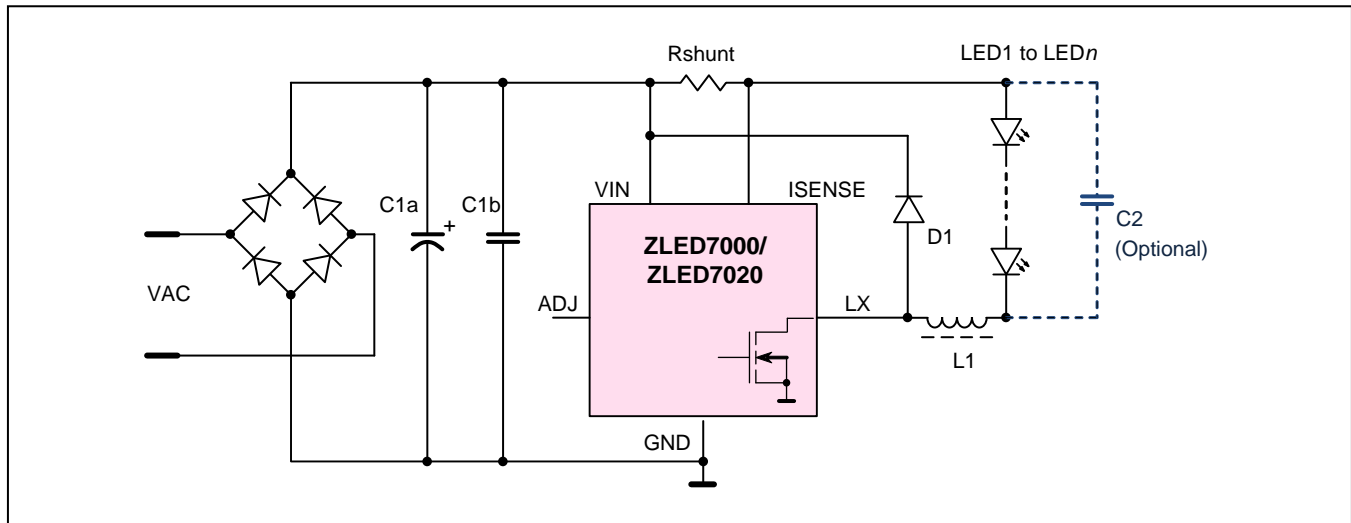

## 8 Application Examples

The following tables contain the bill of materials (BOM) for different supply voltages and LED configurations. They are split into two categories, one for high efficiency at moderate switching frequency and the other for low cost and small outline operating at high switching frequency. Efficiency examples in the tables are based on typical component values at 25°C and may serve to show the dependence on supply voltage, LED string length, and switching frequency.

**Table 8.1 Example BOM for ZLED7000 with DC Supply – High Efficiency with  $I_{LED} = 150\text{ mA}$**

$I_{LED} = 150\text{ mA}$  (0.5 W per LED), high efficiency,  $f = 90\text{ kHz}$  to  $180\text{ kHz}$

Part	12 V 1 to 2 LEDs	24 V 1 to 2 LEDs	24 V 3 to 5 LEDs	36 V <sup>1)</sup> 1 to 2 LEDs	36 V <sup>1)</sup> 3 to 5 LEDs	36 V <sup>1)</sup> 6 to 8 LEDs
L1	470 $\mu\text{H}$ , 0.5 $\Omega$ $I_{SAT} \geq 250\text{ mA}$ Wuerth Elektr. WE-PD 1210 7447709471	680 $\mu\text{H}$ , 0.7 $\Omega$ $I_{SAT} \geq 250\text{ mA}$ Wuerth Elektr. WE-PD 1210 7447709681	1 mH, 1 $\Omega$ $I_{SAT} \geq 250\text{ mA}$ Wuerth Elektr. WE-PD 1210 7447709102	680 $\mu\text{H}$ , 0.7 $\Omega$ $I_{SAT} \geq 250\text{ mA}$ Wuerth Elektr. WE-PD 1210 7447709681	1.5 mH, 2 $\Omega$ $I_{SAT} \geq 250\text{ m}$ Wuerth Elektr. WE-PD 1210 7447709152	1.5 mH, 2 $\Omega$ $I_{SAT} \geq 250\text{ mA}$ Wuerth Elektr. WE-PD 1210 7447709152
D1	Schottky 20 V, 0.5 A MBR 0520	Schottky 40 V, 0.5 A MBR 0540	Schottky 40 V, 0.5 A MBR 0540	Schottky 60 V, 1 A SS 16	Schottky 60 V, 1 A SS 16	Schottky 60 V, 1 A SS 16
Rshunt	640 m $\Omega$ (1 $\Omega$    1.8 $\Omega$ )	640 m $\Omega$ (1 $\Omega$    1.8 $\Omega$ )	640 m $\Omega$ (1 $\Omega$    1.8 $\Omega$ )	640 m $\Omega$ (1 $\Omega$    1.8 $\Omega$ )	640 m $\Omega$ (1 $\Omega$    1.8 $\Omega$ )	640 m $\Omega$ (1 $\Omega$    1.8 $\Omega$ )
C1	1 $\mu\text{F}$ , 16 V	1 $\mu\text{F}$ , 35 V	1 $\mu\text{F}$ , 35 V	1 $\mu\text{F}$ , 63 V	1 $\mu\text{F}$ , 63 V	1 $\mu\text{F}$ , 63 V
C2 <sup>2)3)</sup>	3.3 $\mu\text{F}$ ; 1 $\mu\text{F}$ , 16 V	3.3 $\mu\text{F}$ ; 1 $\mu\text{F}$ , 35 V	680 nF, 35 V	3.3 $\mu\text{F}$ ; 1 $\mu\text{F}$ , 63 V	680 nF, 63 V	330 nF, 63 V
$\eta$ <sup>3)</sup>	86%, 94%	83%, 92%	94% to 97%	79%, 87%	91% to 95%	96% to 98%
<ol style="list-style-type: none"> <li>1. 40 V is maximum supply voltage.</li> <li>2. To reduce ripple current to approx. 10% of average current.</li> <li>3. First value for 1 LED, second for 2 LEDs.</li> </ol>						

**Table 8.2 Example BOM for ZLED7000 with DC Supply – High Frequency with  $I_{LED} = 150\text{ mA}$**

$I_{LED} = 150\text{ mA}$  (0.5 W per LED), high frequency,  $f = 600\text{ kHz}$  to  $1.2\text{ MHz}$

Part	12 V 1 to 2 LEDs	24 V 1 to 2 LEDs	24 V 3 to 5 LEDs	36 V <sup>1)</sup> 1 to 2 LEDs	36 V <sup>1)</sup> 3 to 5 LEDs	36 V <sup>1)</sup> 6 to 8 LEDs
L1	47 $\mu\text{H}$ , 0.35 $\Omega$ $I_{SAT} \geq 250\text{ mA}$ Wuerth Elektr. WE-PD 7332 744778147	68 $\mu\text{H}$ , 0.45 $\Omega$ $I_{SAT} \geq 250\text{ mA}$ Wuerth Elektr. WE-PD 7332 744778168	100 $\mu\text{H}$ , 0.6 $\Omega$ $I_{SAT} \geq 250\text{ mA}$ Wuerth Elektr. WE-PD 7332 74477820	68 $\mu\text{H}$ , 0.45 $\Omega$ $I_{SAT} \geq 250\text{ mA}$ Wuerth Elektr. WE-PD 7332 744778168	120 $\mu\text{H}$ , 0.65 $\Omega$ $I_{SAT} \geq 250\text{ mA}$ Wuerth Elektr. WE-PD 7332 744778212	150 $\mu\text{H}$ , 0.75 $\Omega$ $I_{SAT} \geq 250\text{ mA}$ Wuerth Elektr. WE-PD 7332 744778215
D1	Schottky 20 V, 0.5 A MBR 0520	Schottky 40 V, 0.5 A MBR 0540	Schottky 40 V, 0.5 A MBR 0540	Schottky 60 V, 1 A SS 16	Schottky 60 V, 1 A SS 16	Schottky 60 V, 1 A SS 16
Rshunt	640 m $\Omega$ (1 $\Omega$    1.8 $\Omega$ )	640 m $\Omega$ (1 $\Omega$    1.8 $\Omega$ )	640 m $\Omega$ (1 $\Omega$    1.8 $\Omega$ )	640 m $\Omega$ (1 $\Omega$    1.8 $\Omega$ )	640 m $\Omega$ (1 $\Omega$    1.8 $\Omega$ )	640 m $\Omega$ (1 $\Omega$    1.8 $\Omega$ )
C1	1 $\mu\text{F}$ , 16 V	1 $\mu\text{F}$ , 35 V	1 $\mu\text{F}$ , 35 V	1 $\mu\text{F}$ , 63 V	1 $\mu\text{F}$ , 63 V	1 $\mu\text{F}$ , 63 V
C2 <sup>2) 3)</sup>	390 nF; 220 nF, 16 V	560 nF; 220 nF, 35 V	150 nF, 35 V	820 nF; 270 nF, 63 V	150 nF, 63 V	68 nF, 63 V
$\eta$ <sup>3)</sup>	81%, 89%	76%, 83%	87% to 91%	67%, 74%	80% to 84%	88% to 91%

1. 40 V is maximum supply voltage.  
2. To reduce ripple current to approx. 10% of average current.  
3. First value for 1 LED, second value for 2 LEDs.

**Table 8.3 Example BOM for ZLED7000 with DC Supply – High Efficiency with  $I_{LED} = 400\text{ mA}$**

$I_{LED} = 400\text{ mA}$  (1.3 W per LED), high efficiency,  $f = 90\text{ kHz}$  to  $180\text{ kHz}$

Part	12 V 1 to 2 LEDs	24 V 1 to 2 LEDs	24 V 3 to 5 LEDs	36 V <sup>1)</sup> 1 to 2 LEDs	36 V <sup>1)</sup> 3 to 5 LEDs	36 V <sup>1)</sup> 6 to 8 LEDs
L1	220 $\mu\text{H}$ , 0.3 $\Omega$ $I_{SAT} \geq 600\text{ mA}$ Wuerth Elektr. WE-PD 1280 744770222	330 $\mu\text{H}$ , 0.4 $\Omega$ $I_{SAT} \geq 600\text{ mA}$ Wuerth Elektr. WE-PD 1280 744770233	470 $\mu\text{H}$ , 0.5 $\Omega$ $I_{SAT} \geq 600\text{ mA}$ Wuerth Elektr. WE-PD 1280 744770247	330 $\mu\text{H}$ , 0.4 $\Omega$ $I_{SAT} \geq 600\text{ mA}$ Wuerth Elektr. WE-PD 1280 744770233	470 $\mu\text{H}$ , 0.5 $\Omega$ $I_{SAT} \geq 600\text{ mA}$ Wuerth Elektr. WE-PD 1280 744770247	470 $\mu\text{H}$ , 0.5 $\Omega$ $I_{SAT} \geq 600\text{ mA}$ Wuerth Elektr. WE-PD 1280 744770247
D1	Schottky 20 V, 1 A SS 12	Schottky 40 V, 1 A SS 14	Schottky 40 V, 1 A SS 14	Schottky 60 V, 1 A SS 16	Schottky 60 V, 1 A SS 16	Schottky 60 V, 1 A SS 16
Rshunt	240 m $\Omega$ (0.27    2.2 $\Omega$ )	240 m $\Omega$ (0.27    2.2 $\Omega$ )	240 m $\Omega$ (0.27    2.2 $\Omega$ )	240 m $\Omega$ (0.27    2.2 $\Omega$ )	240 m $\Omega$ (0.27    2.2 $\Omega$ )	240 m $\Omega$ (0.27    2.2 $\Omega$ )
C1	1 $\mu\text{F}$ , 16 V	1 $\mu\text{F}$ , 35 V	1 $\mu\text{F}$ , 35 V	1 $\mu\text{F}$ , 63 V	1 $\mu\text{F}$ , 63 V	1 $\mu\text{F}$ , 63 V
C2 <sup>2) 3)</sup>	4.7 $\mu\text{F}$ ; 2.2 $\mu\text{F}$ , 16 V	4.7 $\mu\text{F}$ ; 2.2 $\mu\text{F}$ , 35 V	1 $\mu\text{F}$ , 35 V	4.7 $\mu\text{F}$ ; 2.2 $\mu\text{F}$ , 63 V	1 $\mu\text{F}$ , 63 V	470 nF, 63 V
$\eta$ <sup>3)</sup>	86%, 93%	83%, 91%	93% to 96%	81%, 88%	92% to 95%	96% to 97%

1. 40 V is maximum supply voltage.  
2. To reduce ripple current to approx. 10% of average current.  
3. First value for 1 LED, second for 2 LEDs.

**Table 8.4 Example BOM for ZLED7000 with DC Supply – High Frequency with  $I_{LED} = 400\text{ mA}$**

$I_{LED} = 400\text{ mA}$  (1.3 W per LED), high frequency,  $f = 600\text{ kHz}$  to  $1.2\text{ MHz}$

Part	12 V 1 to 2 LEDs	24 V 1 to 2 LEDs	24 V 3 to 5 LEDs	36 V <sup>1)</sup> 1 to 2 LEDs	36 V <sup>1)</sup> 3 to 5 LEDs	36 V <sup>1)</sup> 6 to 8 LEDs
L1	22 $\mu\text{H}$ , 0.1 $\Omega$ $I_{SAT} \geq 600\text{ mA}$ Wuerth Elektr. WE-PD 7345 744777122	27 $\mu\text{H}$ , 0.12 $\Omega$ $I_{SAT} \geq 600\text{ mA}$ Wuerth Elektr. WE-PD 7345 744777127	39 $\mu\text{H}$ , 0.15 $\Omega$ $I_{SAT} \geq 600\text{ mA}$ Wuerth Elektr. WE-PD 7345 744777139	33 $\mu\text{H}$ , 0.14 $\Omega$ $I_{SAT} \geq 600\text{ mA}$ Wuerth Elektr. WE-PD 7345 744777133	56 $\mu\text{H}$ , 0.2 $\Omega$ $I_{SAT} \geq 600\text{ mA}$ Wuerth Elektr. WE-PD 7345 744777156	56 $\mu\text{H}$ , 0.2 $\Omega$ $I_{SAT} \geq 600\text{ mA}$ Wuerth Elektr. WE-PD 7345 744777156
D1	Schottky 20 V, 1 A SS 12	Schottky 40 V, 1 A SS 14	Schottky 40 V, 1 A SS 14	Schottky 60 V, 1 A BAT 160	Schottky 60 V, 1 A BAT 160	Schottky 60 V, 1 A BAT 160
Rshunt	240 m $\Omega$ (0.27    2.2 $\Omega$ )	240 m $\Omega$ (0.27    2.2 $\Omega$ )	240 m $\Omega$ (0.27    2.2 $\Omega$ )	240 m $\Omega$ (0.27    2.2 $\Omega$ )	240 m $\Omega$ (0.27    2.2 $\Omega$ )	240 m $\Omega$ (0.27    2.2 $\Omega$ )
C1	1 $\mu\text{F}$ , 16 V	1 $\mu\text{F}$ , 35 V	1 $\mu\text{F}$ , 35 V	1 $\mu\text{F}$ , 63 V	1 $\mu\text{F}$ , 63 V	1 $\mu\text{F}$ , 63 V
C2 <sup>2) 3)</sup>	560 nF; 270 nF, 16 V	680nF; 220 nF, 35 V	150 nF, 35 V	820nF; 270 nF, 63 V	220 nF, 63 V	100 nF, 63 V
$\eta$ <sup>3)</sup>	81%, 89%	75%, 83%	87% to 91%	72%, 79%	83% to 87%	89% to 92%

1. 40 V is maximum supply voltage.  
 2. To reduce ripple current to approx. 10% of average current.  
 3. First value for 1 LED, second for 2 LEDs.

**Table 8.5 Example BOM for ZLED7000/ZLED7020 with DC Supply – High Efficiency with  $I_{LED} = 700\text{ mA}$**

$I_{LED} = 700\text{ mA}$  (2.2 W per LED), high efficiency,  $f = 90\text{ kHz}$  to  $180\text{ kHz}$

Part	12 V 1 to 2 LEDs	24 V 1 to 2 LEDs	24 V 3 to 5 LEDs	36 V <sup>1)</sup> 1 to 2 LEDs	36 V <sup>1)</sup> 3 to 5 LEDs	36 V <sup>1)</sup> 6 to 8 LEDs
L1	100 $\mu\text{H}$ , 0.1 $\Omega$ $I_{SAT} \geq 1.1\text{ A}$ Wuerth Elektr. WE-PD 1210 7447709101	150 $\mu\text{H}$ , 0.16 $\Omega$ $I_{SAT} \geq 1.1\text{ A}$ Wuerth Elektr. WE-PD 1210 7447709151	150 $\mu\text{H}$ , 0.16 $\Omega$ $I_{SAT} \geq 1.1\text{ A}$ Wuerth Elektr. WE-PD 1210 7447709151	150 $\mu\text{H}$ , 0.16 $\Omega$ $I_{SAT} \geq 1.1\text{ A}$ Wuerth Elektr. WE-PD 1210 7447709151	270 $\mu\text{H}$ , 0.25 $\Omega$ $I_{SAT} \geq 1.1\text{ A}$ Wuerth Elektr. WE-PD 1210 7447709271	270 $\mu\text{H}$ , 0.25 $\Omega$ $I_{SAT} \geq 1.1\text{ A}$ Wuerth Elektr. WE-PD 1210 7447709271
D1	Schottky 20 V, 1 A SS 12	Schottky 40 V, 1 A SS 14	Schottky 40 V, 1 A SS 14	Schottky 60 V, 1 A SS 16	Schottky 60 V, 1 A SS 16	Schottky 60 V, 1 A SS 16
Rshunt	137 m $\Omega$ (0.15    1.6 $\Omega$ )	137 m $\Omega$ (0.15    1.6 $\Omega$ )	137 m $\Omega$ (0.15    1.6 $\Omega$ )	137 m $\Omega$ (0.15    1.6 $\Omega$ )	137 m $\Omega$ (0.15    1.6 $\Omega$ )	137 m $\Omega$ (0.15    1.6 $\Omega$ )
C1	1 $\mu\text{F}$ , 16 V	1 $\mu\text{F}$ , 35 V	1 $\mu\text{F}$ , 35 V	1 $\mu\text{F}$ , 63 V	1 $\mu\text{F}$ , 63 V	1 $\mu\text{F}$ , 63 V

Part	12 V 1 to 2 LEDs	24 V 1 to 2 LEDs	24 V 3 to 5 LEDs	36 V <sup>1)</sup> 1 to 2 LEDs	36 V <sup>1)</sup> 3 to 5 LEDs	36 V <sup>1)</sup> 6 to 8 LEDs
C2 <sup>2) 3)</sup>	3.3 $\mu$ F; 2.2 $\mu$ F, 16 V	4.7 $\mu$ F; 2.2 $\mu$ F, 35 V	820 nF, 35 V	4.7 $\mu$ F; 2.2 $\mu$ F, 63 V	1 $\mu$ F, 63 V	560nF, 63 V
$\eta$ (7000) <sup>3)</sup>	84%, 90%	83%, 89%	92% to 95%	82%, 89%	92% to 94%	95% to 96%
$\eta$ (7020) <sup>3)</sup>	86%, 92%	85%, 90%	93% to 96%	84%, 90%	93% to 95%	96% to 97%
<ol style="list-style-type: none"> <li>40 V is maximum supply voltage.</li> <li>To reduce ripple current to approx. 10% of average current.</li> <li>First value for 1 LED, second for 2 LEDs.</li> </ol>						

**Table 8.6 Example BOM for ZLED7000/ZLED7020 with DC Supply – High Frequency with  $I_{LED} = 700$  mA**  
 $I_{LED} = 700$  mA (2.2 W per LED), high frequency,  $f = 600$  kHz to 1.2 MHz

Part	12 V 1 to 2 LEDs	24 V 1 to 2 LEDs	24 V 3 to 5 LEDs	36 V <sup>1)</sup> 1 to 2 LEDs	36 V <sup>1)</sup> 3 to 5 LEDs	36 V <sup>1)</sup> 6 to 8 LEDs
L1	10 $\mu$ H, 50 m $\Omega$ $I_{SAT} \geq 1.1$ A Wuerth Elektr. WE-PD 7345 74477710	15 $\mu$ H, 70 m $\Omega$ $I_{SAT} \geq 1.1$ A Wuerth Elektr. WE-PD 7345 744777115	22 $\mu$ H, 0.1 $\Omega$ $I_{SAT} \geq 1.1$ A Wuerth Elektr. WE-PD 7345 744777122	18 $\mu$ H, 80 m $\Omega$ $I_{SAT} \geq 1.1$ A Wuerth Elektr. WE-PD 7345 744777118	33 $\mu$ H, 0.14 $\Omega$ $I_{SAT} \geq 1.1$ A Wuerth Elektr. WE-PD 7345 744777133	33 $\mu$ H, 0.14 $\Omega$ $I_{SAT} \geq 1.1$ A Wuerth Elektr. WE-PD 7345 744777133
D1	Schottky 20 V, 1 A SS 12	Schottky 40 V, 1 A SS 14	Schottky 40 V, 1 A SS 14	Schottky 60 V, 1 A SS 16	Schottky 60 V, 1 A SS 16	Schottky 60 V, 1 A SS 16
Rshunt	137 m $\Omega$ (0.15    1.6 $\Omega$ )	137 m $\Omega$ (0.15    1.6 $\Omega$ )	137 m $\Omega$ (0.15    1.6 $\Omega$ )	137 m $\Omega$ (0.15    1.6 $\Omega$ )	137 m $\Omega$ (0.15    1.6 $\Omega$ )	137 m $\Omega$ (0.15    1.6 $\Omega$ )
C1	1 $\mu$ F, 16 V	1 $\mu$ F, 35 V	1 $\mu$ F, 35 V	1 $\mu$ F, 63 V	1 $\mu$ F, 63 V	1 $\mu$ F, 63 V
C2 <sup>2) 3)</sup>	560 nF; 270 nF 16 V	680 nF; 330 nF 35 V	150 nF, 35 V	820 nF; 680 nF 63 V	220 nF, 63 V	120 nF, 63 V
$\eta$ (7000) <sup>3)</sup>	79%, 87%	75%, 82%	87% to 91%	71%, 79%	84% to 88%	90% to 92%
$\eta$ (7020) <sup>3)</sup>	81%, 89%	77%, 84%	89% to 92%	74%, 81%	85% to 89%	91% to 93%
<ol style="list-style-type: none"> <li>40 V is maximum supply voltage.</li> <li>To reduce ripple current to approx. 10% of average current.</li> <li>First value for 1 LED, second for 2 LEDs.</li> </ol>						

**Table 8.7 Example BOM for ZLED7020 with DC Supply – High Efficiency with  $I_{LED} = 1 A$**

$I_{LED} = 1 A$  (3.2 W per LED), high efficiency,  $f = 90 \text{ kHz}$  to  $180 \text{ kHz}$

Part	12 V 1 to 2 LEDs	24 V 1 to 2 LEDs	24 V 3 to 5 LEDs	36 V <sup>1)</sup> 1 to 2 LEDs	36 V <sup>1)</sup> 3 to 5 LEDs	36 V <sup>1)</sup> 6 to 8 LEDs
L1	68 $\mu\text{H}$ , 70 $\text{m}\Omega$ $I_{SAT} \geq 1.5 A$ Wuerth Elektr. WE-PD 1210 7447709680	150 $\mu\text{H}$ , 0.16 $\Omega$ $I_{SAT} \geq 1.5 A$ Wuerth Elektr. WE-PD 1210 7447709151	150 $\mu\text{H}$ , 0.16 $\Omega$ $I_{SAT} \geq 1.5 A$ Wuerth Elektr. WE-PD 1210 7447709151	220 $\mu\text{H}$ , 0.2 $\Omega$ $I_{SAT} \geq 1.5 A$ Wuerth Elektr. WE-PD 1210 7447709221	220 $\mu\text{H}$ , 0.2 $\Omega$ $I_{SAT} \geq 1.5 A$ Wuerth Elektr. WE-PD 1210 7447709221	150 $\mu\text{H}$ , 0.16 $\Omega$ $I_{SAT} \geq 1.5 A$ Wuerth Elektr. WE-PD 1210 7447709151
D1	Schottky 20 V, 2 A SS 22	Schottky 40 V, 2 A SS 24	Schottky 40 V, 2 A SS 24	Schottky 60 V, 2 A SS 26	Schottky 60 V, 2 A SS 26	Schottky 60 V, 2 A SS 26
Rshunt	137 $\text{m}\Omega$ (0.15    1.6 $\Omega$ )	137 $\text{m}\Omega$ (0.15    1.6 $\Omega$ )	137 $\text{m}\Omega$ (0.15    1.6 $\Omega$ )	137 $\text{m}\Omega$ (0.15    1.6 $\Omega$ )	137 $\text{m}\Omega$ (0.15    1.6 $\Omega$ )	137 $\text{m}\Omega$ (0.15    1.6 $\Omega$ )
C1	1 $\mu\text{F}$ , 16 V	1 $\mu\text{F}$ , 35 V	1 $\mu\text{F}$ , 35 V	1 $\mu\text{F}$ , 63 V	1 $\mu\text{F}$ , 63 V	1 $\mu\text{F}$ , 63 V
C2 <sup>2) 3)</sup>	4.7 $\mu\text{F}$ ; 2.2 $\mu\text{F}$ 16 V	5.6 $\mu\text{F}$ ; 3.3 $\mu\text{F}$ 35 V	1.5 $\mu\text{F}$ , 35 V	6.8 $\mu\text{F}$ ; 3.3 $\mu\text{F}$ 63 V	1.5 $\mu\text{F}$ , 63 V	680 nF, 63 V
$\eta$ <sup>3)</sup>	85%, 92%	84%, 91%	93% to 96%	83%, 90%	93% to 96%	96% to 97%

1. 40 V is maximum supply voltage.  
2. To reduce ripple current to approx. 10% of average current.  
3. First value for 1 LED, second for 2 LEDs.

**Table 8.8 Example BOM for ZLED7020 with DC Supply – High Frequency with  $I_{LED} = 1 A$**

$I_{LED} = 1 A$  (3.2 W per LED), high frequency,  $f = 600 \text{ kHz}$  to  $1.2 \text{ MHz}$

Part	12 V 1 to 2 LEDs	24 V 1 to 2 LEDs	24 V 3 to 5 LEDs	36 V <sup>1)</sup> 1 to 2 LEDs	36 V <sup>1)</sup> 3 to 5 LEDs	36 V <sup>1)</sup> 6 to 8 LEDs
L1	6.8 $\mu\text{H}$ , 15 $\text{m}\Omega$ $I_{SAT} \geq 1.5 A$ Wuerth Elektr. WE-PD 1260 744771006	10 $\mu\text{H}$ , 18 $\text{m}\Omega$ $I_{SAT} \geq 1.5 A$ Wuerth Elektr. WE-PD 1260 744771110	15 $\mu\text{H}$ , 25 $\text{m}\Omega$ $I_{SAT} \geq 1.5 A$ Wuerth Elektr. WE-PD 1260 744771115	12 $\mu\text{H}$ , 23 $\text{m}\Omega$ $I_{SAT} \geq 1.5 A$ Wuerth Elektr. WE-PD 1260 744771112	18 $\mu\text{H}$ , 29 $\text{m}\Omega$ $I_{SAT} \geq 1.5 A$ Wuerth Elektr. WE-PD 1260 744771118	18 $\mu\text{H}$ , 29 $\text{m}\Omega$ $I_{SAT} \geq 1.5 A$ Wuerth Elektr. WE-PD 1260 744771118
D1	Schottky 20 V, 2 A SS 22	Schottky 40 V, 2 A SS 24	Schottky 40 V, 2 A SS 24	Schottky 60 V, 2 A SS 26	Schottky 60 V, 2 A SS 26	Schottky 60 V, 2 A SS 26
Rshunt	137 $\text{m}\Omega$ (0.15    1.6 $\Omega$ )	137 $\text{m}\Omega$ (0.15    1.6 $\Omega$ )	137 $\text{m}\Omega$ (0.15    1.6 $\Omega$ )	137 $\text{m}\Omega$ (0.15    1.6 $\Omega$ )	137 $\text{m}\Omega$ (0.15    1.6 $\Omega$ )	137 $\text{m}\Omega$ (0.15    1.6 $\Omega$ )
C1	1 $\mu\text{F}$ , 16 V	1 $\mu\text{F}$ , 35 V	1 $\mu\text{F}$ , 35 V	1 $\mu\text{F}$ , 63 V	1 $\mu\text{F}$ , 63 V	1 $\mu\text{F}$ , 63 V
C2 <sup>2) 3)</sup>	680 nF; 330 nF, 16 V	680 nF; 330 nF, 35 V	220 nF, 35 V	820 nF; 330 nF, 63 V	220 nF, 63 V	120 nF, 63 V
$\eta$ <sup>3)</sup>	79%, 88%	77%, 84%	89% to 92%	74%, 80%	87% to 90%	92% to 94%

1. 40 V is maximum supply voltage.  
2. To reduce ripple current to approx. 10% of average current.  
3. First value for 1 LED, second for 2 LEDs.

**Table 8.9 Shunt Resistor Selection**

$I_{LED}$ (mA)	Rshunt (m $\Omega$ )	Equivalent Combination of 2 Resistors Connected in Parallel
75	1280	1.5 $\Omega$    9.1 $\Omega$
100	960	1 $\Omega$    24 $\Omega$
150	640	1 $\Omega$    1.8 $\Omega$
200	480	560 m $\Omega$    3.3 $\Omega$
250	384	390 m $\Omega$    24 $\Omega$
300	320	330 m $\Omega$    10 $\Omega$
350	274	330 m $\Omega$    1.6 $\Omega$
400	240	270 m $\Omega$    2.2 $\Omega$
500	192	220 m $\Omega$    1.5 $\Omega$
600	160	180 m $\Omega$    1.5 $\Omega$
700	137	150 m $\Omega$    1.6 $\Omega$
750	128	150 m $\Omega$    910 m $\Omega$
800	120	120 m $\Omega$
900	106.7	120 m $\Omega$    1 $\Omega$
1000	96	100 m $\Omega$    2.4 $\Omega$
1100	87.3	100 m $\Omega$    680 m $\Omega$
1200	80	100 m $\Omega$    390 m $\Omega$

## 9 Document Revision History

Revision	Date	Description
1.0	June 1, 2011	First release.
	April 18, 2016	Changed to IDT branding.

## IMPORTANT NOTICE AND DISCLAIMER

RENESAS ELECTRONICS CORPORATION AND ITS SUBSIDIARIES (“RENESAS”) PROVIDES TECHNICAL SPECIFICATIONS AND RELIABILITY DATA (INCLUDING DATASHEETS), DESIGN RESOURCES (INCLUDING REFERENCE DESIGNS), APPLICATION OR OTHER DESIGN ADVICE, WEB TOOLS, SAFETY INFORMATION, AND OTHER RESOURCES “AS IS” AND WITH ALL FAULTS, AND DISCLAIMS ALL WARRANTIES, EXPRESS OR IMPLIED, INCLUDING, WITHOUT LIMITATION, ANY IMPLIED WARRANTIES OF MERCHANTABILITY, FITNESS FOR A PARTICULAR PURPOSE, OR NON-INFRINGEMENT OF THIRD-PARTY INTELLECTUAL PROPERTY RIGHTS.

These resources are intended for developers who are designing with Renesas products. You are solely responsible for (1) selecting the appropriate products for your application, (2) designing, validating, and testing your application, and (3) ensuring your application meets applicable standards, and any other safety, security, or other requirements. These resources are subject to change without notice. Renesas grants you permission to use these resources only to develop an application that uses Renesas products. Other reproduction or use of these resources is strictly prohibited. No license is granted to any other Renesas intellectual property or to any third-party intellectual property. Renesas disclaims responsibility for, and you will fully indemnify Renesas and its representatives against, any claims, damages, costs, losses, or liabilities arising from your use of these resources. Renesas' products are provided only subject to Renesas' Terms and Conditions of Sale or other applicable terms agreed to in writing. No use of any Renesas resources expands or otherwise alters any applicable warranties or warranty disclaimers for these products.

(Disclaimer Rev.1.01)

### Corporate Headquarters

TOYOSU FORESIA, 3-2-24 Toyosu,  
Koto-ku, Tokyo 135-0061, Japan  
[www.renesas.com](http://www.renesas.com)

### Trademarks

Renesas and the Renesas logo are trademarks of Renesas Electronics Corporation. All trademarks and registered trademarks are the property of their respective owners.

### Contact Information

For further information on a product, technology, the most up-to-date version of a document, or your nearest sales office, please visit [www.renesas.com/contact-us/](http://www.renesas.com/contact-us/).