

RX671 Group

RX671 OTA-supported HMI sample program with touch keys and LCD

Introduction

This application note describes a sample program to realize touch function and serial LCD display using Renesas Starter Kit+ for RX671 and separately sold LCD module.

In addition, introduce the function to connect to the cloud and perform firmware updates using OTA.

The sample program described in this application note is configured using the following libraries.

LCD Display : Embedded GUI software emWin (hereinafter referred to as “emWin”)

Target Device

RX671 Group

When using this application note with other Renesas MCUs, careful evaluation is recommended after making modifications to comply with the alternate MCU.

Target Tool

Renesas Starter Kit+ for RX671

For more information on security, please refer to “Renesas MCU Firmware Update Design Policy (R01AN5548)”.

Contents

1. Outline.....	5
2. Operation Confirmation Conditions	7
3. Hardware Preparation.....	8
3.1 PMOD2 setting	8
3.2 Touch interface setting	8
3.3 Connecting to LCD module	9
4. Sample Program.....	10
4.1 Demonstration Screen Flowchart	10
4.2 Flowchart	13
4.2.1 Overall flowchart of LCD control.....	13
4.2.2 Processing of menu screen display on LCD	14
4.2.3 Processing at moving to the menu screen	15
4.2.4 Processing at touch keys operation	16
4.2.5 Processing at touch slider operation	17
4.2.6 Processing when the "1" button is touched	18
4.2.7 Processing when the "2" button is touched (1)	19
4.2.8 Processing when the "2" button is touched (2)	20
4.2.9 Processing during cooking	21
4.2.10 Overall flowchart of touch control	22
4.2.11 Processing of touch judgement	23
4.2.12 Processing of startup screen display	24
4.2.13 Processing of 5 seconds wait.....	25
4.2.14 Processing of flag clear for touch	26
4.3 Pins Used	27
4.4 Sample Program Structure	28
4.4.1 Peripheral Functions Used	28
4.4.2 Components Used.....	28
4.4.3 Peripheral Function Settings	29
4.4.4 File Structure	34
4.4.5 Variables.....	35
4.4.6 Constants	36
4.4.7 Functions	37
4.4.8 Function Specifications	38
4.4.9 ROM/RAM usage	40
5. Importing a Project.....	41
5.1 Procedure in e ² studio	41
5.2 Procedure in CS+	42

6.	Start Demonstration.....	43
6.1	Powered on Renesas Starter Kit+ for RX671 and menu screen.....	44
6.2	Menu screen.....	44
6.3	Cook setting.....	45
6.3.1	Move to mode selection screen.....	45
6.3.2	Select mode.....	45
6.3.3	Select Auto	46
6.3.4	Select Manual.....	46
6.3.4.1	Set the number of watts	47
6.3.4.2	Move the cursor.....	47
6.3.4.3	Set the number of seconds	48
6.3.4.4	Start cooking	48
6.4	Defrost setting	49
6.4.1	Move to mode selection screen.....	49
6.4.2	Select mode.....	49
6.4.3	Select Manual.....	50
6.4.3.1	Set the level of defrosting.....	50
6.4.3.2	Move the cursor.....	51
6.4.3.3	Set the number of grams.....	51
6.4.3.4	Start defrosting	52
6.4.4	Select Fish.....	52
6.4.5	Select Meat.....	53
6.5	Recipe setting.....	54
6.5.1	Move to recipe selection screen.....	54
6.5.2	Select recipe.....	54
6.5.3	Select Beef Stew	55
6.5.4	Select Garlic Shrimp.....	55
6.5.5	Select Cup Cake.....	56
6.5.5.1	Set the number of cupcakes	56
6.5.5.2	Start cooking	57
6.6	About the “1” button.....	58
6.7	About the cooking completion screen	59
6.8	Automatic LCD off function.....	59
7.	Update firmware version.....	60
8.	How to create a user program that supports OTA.....	66
8.1	AWS Preparation.....	66
8.2	Import, configurate head file and build aws_demos and boot_loader.....	66
8.3	Install the initial version of firmware	76
9.	Restriction	84

10. Reference Documents 85

Revision History 86

1. Outline

This application note describes a sample program to realize touch function and serial LCD display using Renesas Starter Kit+ for RX671 and separately sold LCD module.

The touch buttons and touch slider and LCD (240 x 320) module in Renesas Starter Kit+ for RX671 are used to control the configuration and display of the UI, which imitates a microwave oven.

The system configuration is shown below.

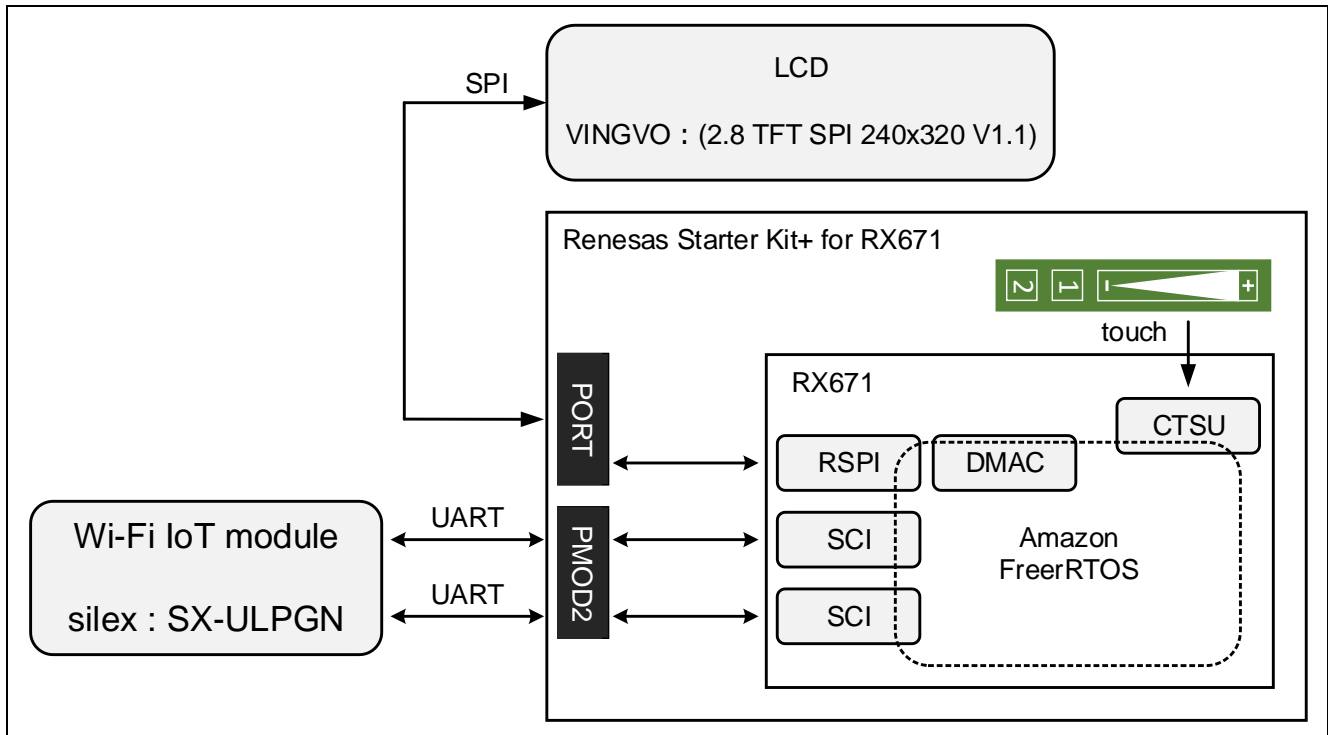

Figure 1-1 System configuration

The software configuration is shown below.

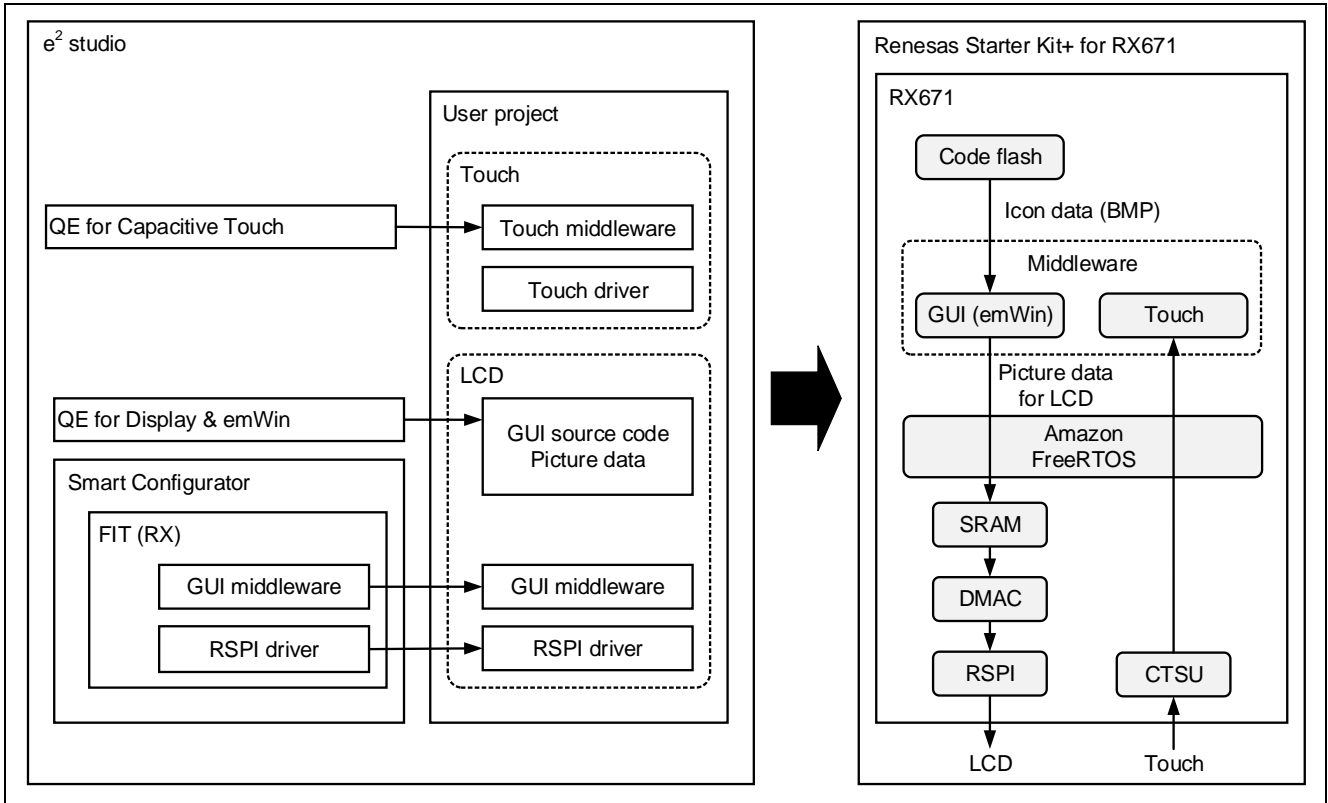

Figure 1-2 Software configuration

2. Operation Confirmation Conditions

The operation of the sample program has been confirmed under the following conditions.

Table 2-1 Operation Confirmation Conditions

Item	Contents
MCU used	R5F5671EHDFB (RX671 Group)
Operating frequency	Operating frequency (ICLK) : 120MHz Peripheral operating frequency (PCLKB) : 60MHz
Operating voltage	3.3 V
Integrated development	Renesas Electronics e ² studio Version 2023-01 (23.1.0)
C compiler	Renesas Electronics C/C++ Compiler Package for RX Family V3.05.00
	Compiler option Default settings of integrated development environment
Smart Configurator	RX 2.16.0
Board support package (r_bsp)	V7.21
Endian order	Little Endian
Operating mode	Single chip mode
Processor mode	Super visor mode
Sample code version	V1.00
Board used	Renesas Starter Kit+ for RX671 (RTK55671EHS10000BE)

Table 2-2 Operation Confirmation Conditions (LCD, Wi-Fi)

Item	Contents
LCD module	2.8 TFT SPI 240 × 320 serial port module
Wi-Fi module	Wi-Fi-Pmod-Expansion-Board (RTK00WFMX0B00000BE)

3. Hardware Preparation

3.1 PMOD2 setting

This application note uses the Wi-Fi-Pmod-Expansion-Board (RTK00WFMX0B00000BE) as a Wi-Fi module. The Wi-Fi module should be set below to connect to PMOD2 on the Renesas Starter Kit+ for RX671.

Table 3-1 PMOD2 jumper setting

Pin name	Signal	Jumper/Resistor	Setting
P12	PMOD2-IO2_MISO_RXD_SCL	J21	Pin2 - 3 short
		R152	Remove
P13	PMOD2-IO1_MOSI_TXD	J17	Pin1 - 2 short
		J18	Pin2 - 3 short
		R114	Remove
P32	PMOD2-IO6_CS1_WIFITXD	J23	Pin2 - 3 short
		R208	Remove
P33	PMOD2-IO7_CS2_WIFIRXD	J22	Pin2 - 3 short
		R189	Remove
P51	PMOD2-IO3_SCK_RTS	J19	Pin1 - 2 short
		R225	Remove

For more information on connecting the Wi-Fi module, refer to "Getting started with the Renesas Starter Kit+ for RX671 (R01QS0056)".

3.2 Touch interface setting

This application note uses a touch interface. Please set up below.

Table 3-2 Touch interface setting

Pin name	Signal	Jumper	Setting
P20	TS9	J11	Pin1 - 2 short

For details, refer to "RX671 Group Renesas Starter Kit+ for RX671 User's Manual (R20UT4879)".

3.3 Connecting to LCD module

Connect Renesas Starter Kit+ for RX671 to the LCD module as follows.

Table 3-3 Connection Table

Renesas Starter Kit+ for RX671		2.8 TFT LCD Panel (J2)		Supplement
Pin number	Pin Name	Pin Number	Pin Name	
-	-	14	T_IRQ	OPEN
-	-	13	T_DO	OPEN
-	-	12	T_DIN	OPEN
-	-	11	T_CS	OPEN
-	-	10	T_CLK	OPEN
JA2-18	MISO	9	MISO	-
9 (PMOD1)	GPIO/CS2	8	LED	-
7 (PMOD1)	SCK	7	SCK	-
JA2-17	MOSI	6	MOSI	-
10 (PMOD1)	GPIO/CS3	5	D/C	-
8 (PMOD1)	GPIO/RESET	4	RESET	-
1 (PMOD1)	CS	3	CS	-
5 (PMOD1)	GND	2	GND	-
6 (PMOD1)	3V3	1	VCC	-

Renesas Starter Kit+ for RX671		2.8 TFT LCD Panel (J4)		Supplement
Pin number	Pin Name	Pin Number	Pin Name	
-	-	1	SD_CS	OPEN
-	-	2	SD_MOSI	OPEN
-	-	3	SD_MISO	OPEN
-	-	4	SD_SCK	OPEN

4. Sample Program

4.1 Demonstration Screen Flowchart

The demonstration screen flowchart of this sample program is shown below. For detail on each screen, refer to chapter 6.

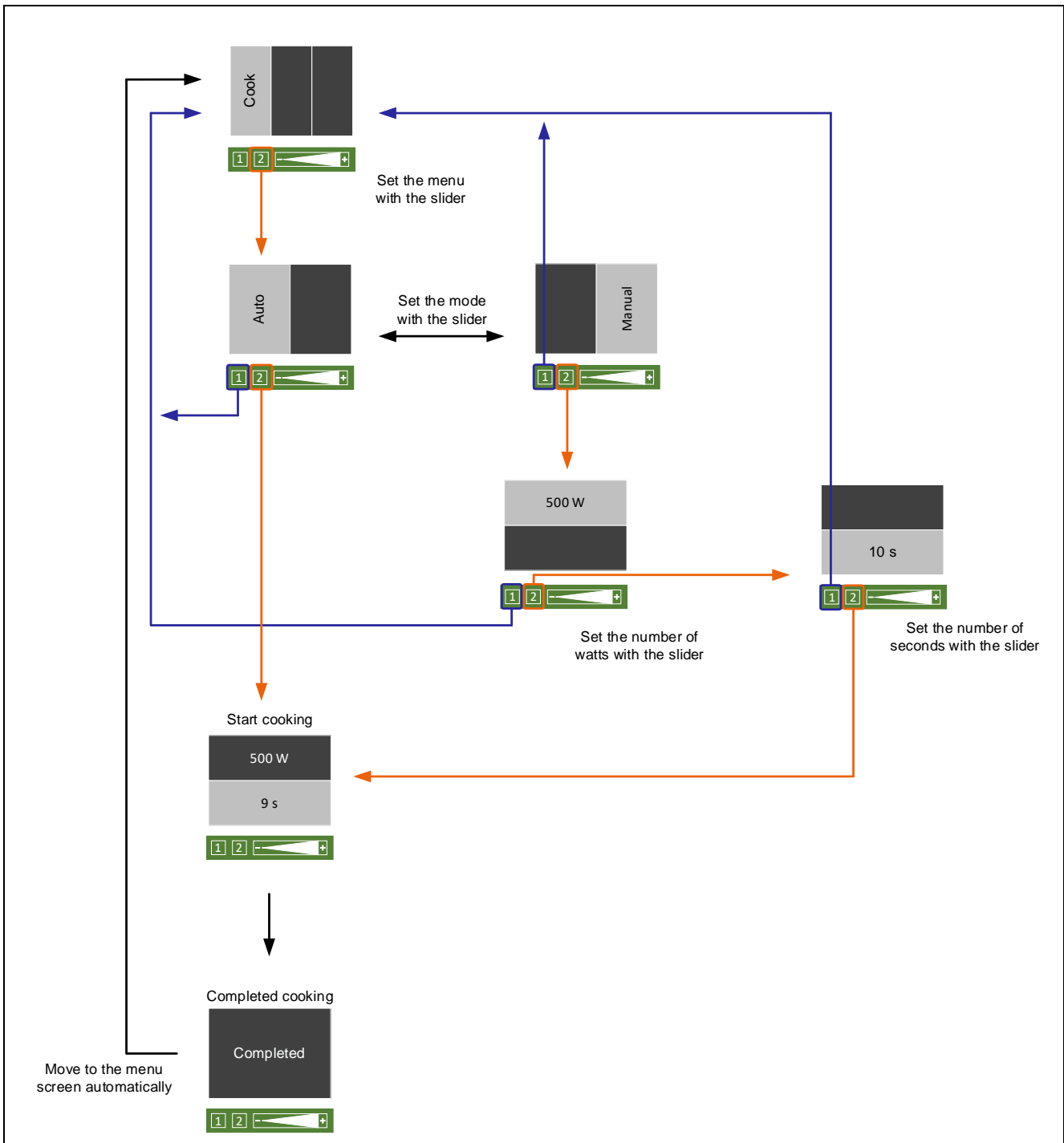

Figure 4-1 Flowchart of demonstration screen (Cook)

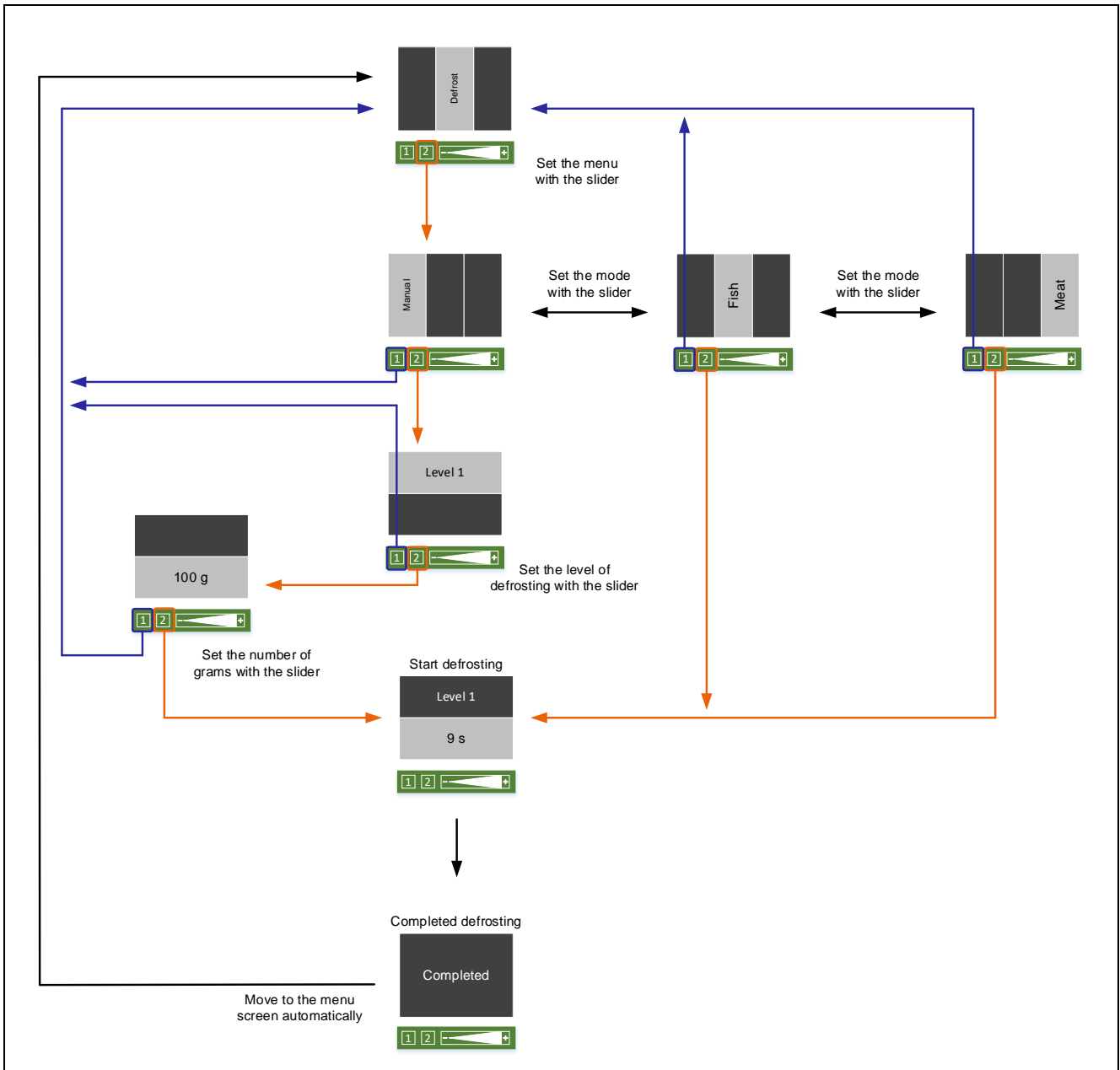

Figure 4-2 Flowchart of demonstration screen (Defrost)

Recipe mode is not available with the firmware ver.0.90.

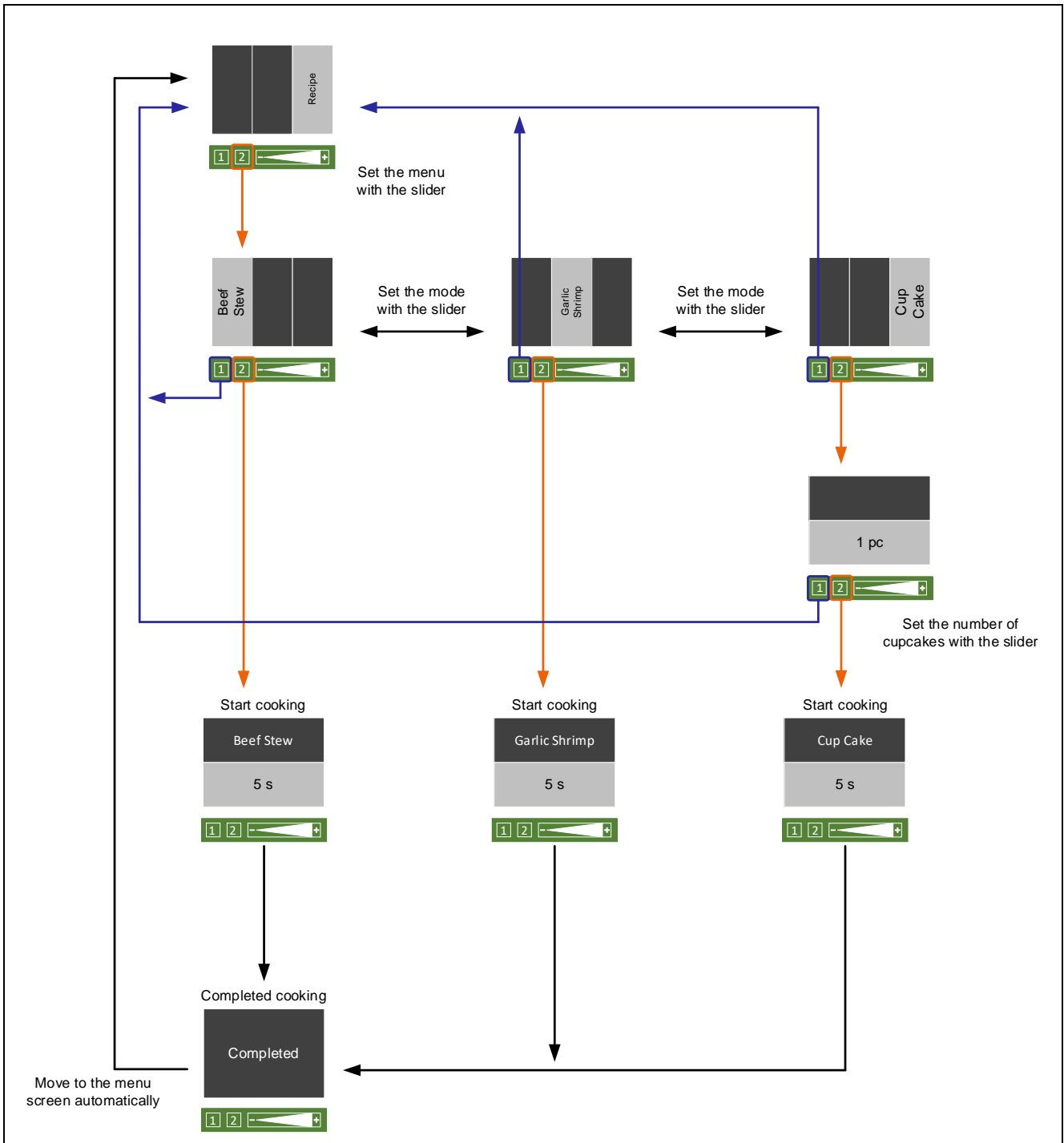

Figure 4-3 Flowchart of demonstration screen (Recipe)

4.2 Flowchart

4.2.1 Overall flowchart of LCD control

The overall flowchart of LCD control is shown below.

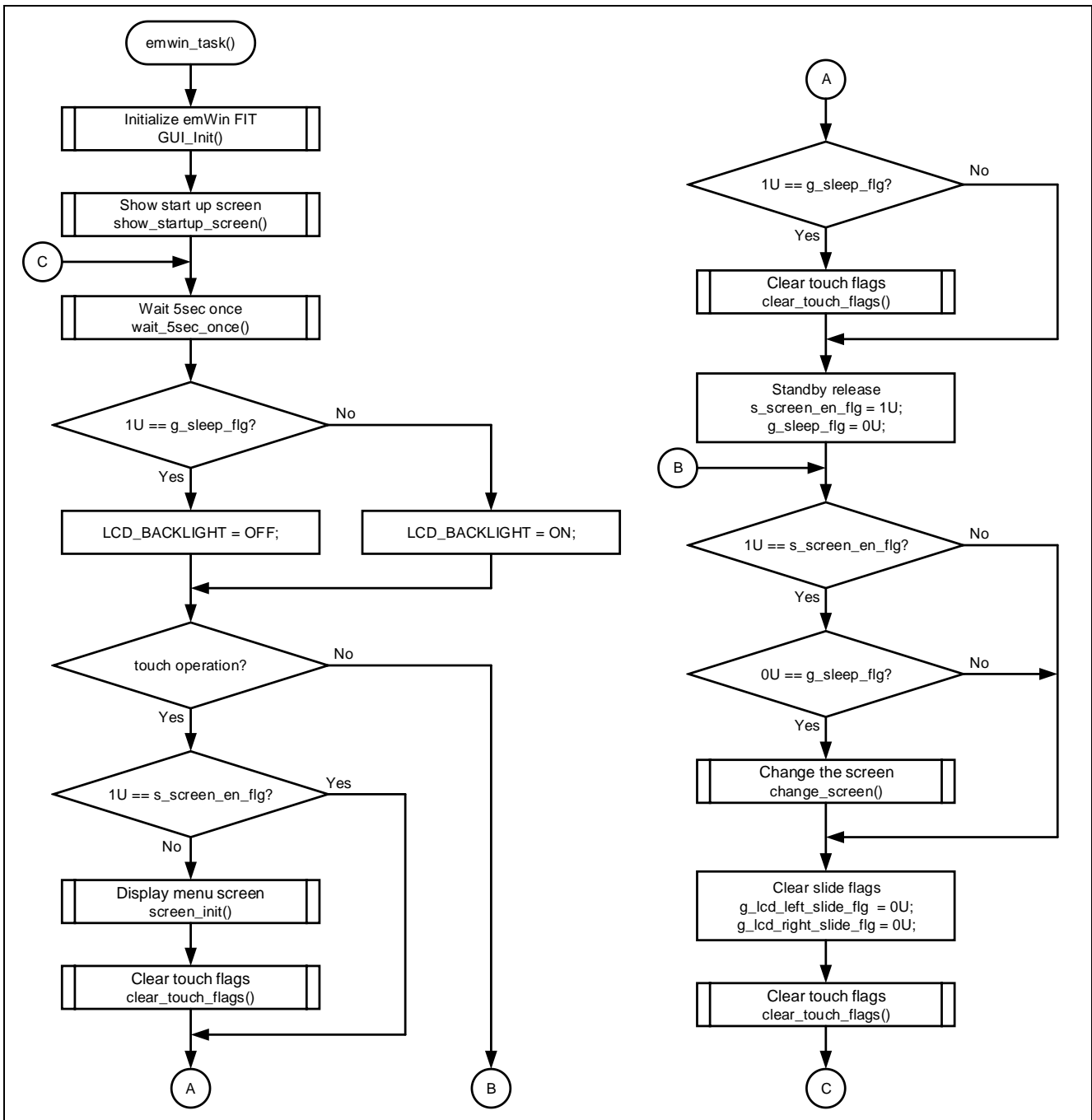

Figure 4-4 Overall flowchart of LCD control

4.2.2 Processing of menu screen display on LCD

The flowchart of menu screen display on LCD is shown below.

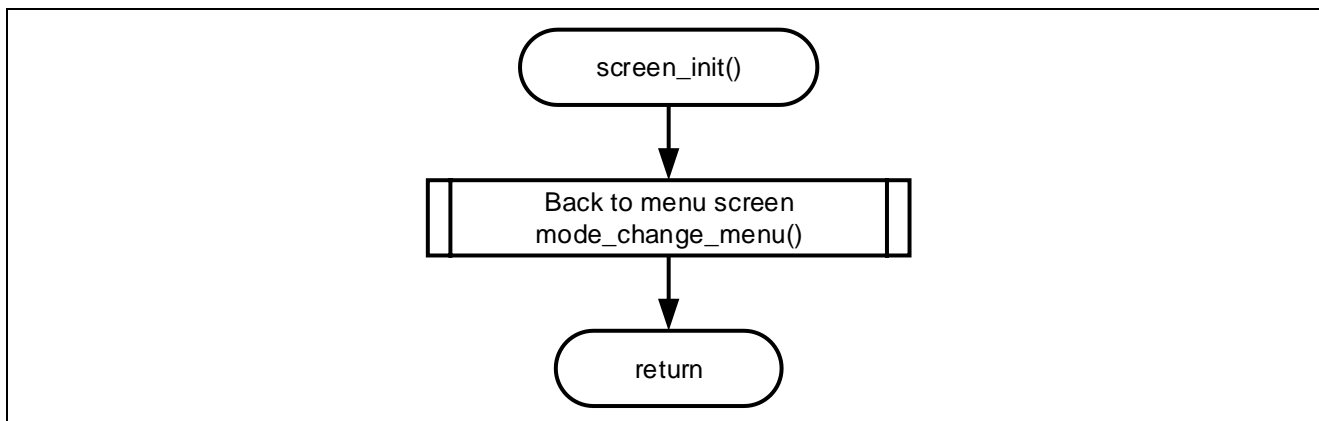

Figure 4-5 Flowchart of menu screen display on LCD

4.2.3 Processing at moving to the menu screen

The flowchart for moving to the menu screen is shown below.

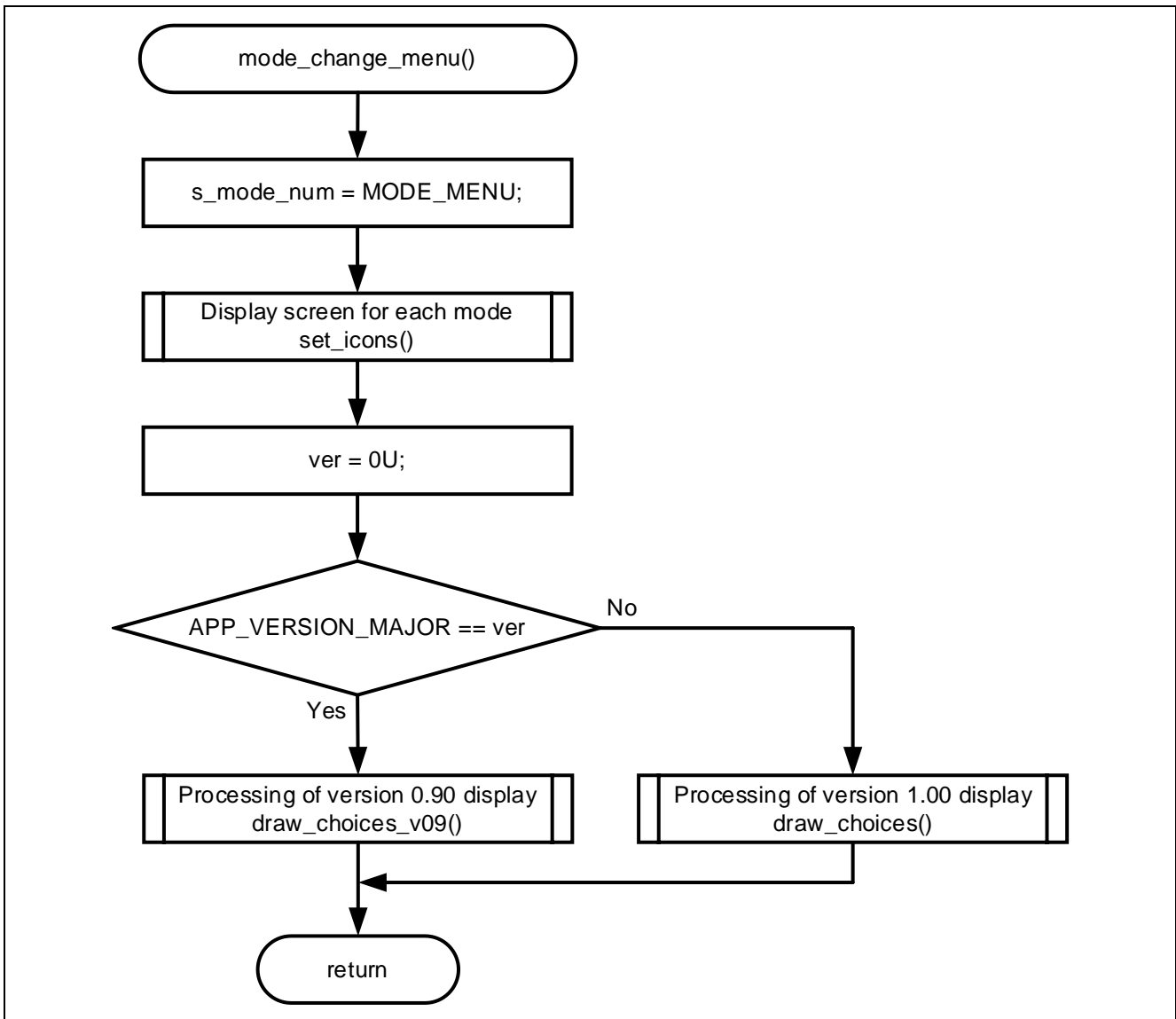

Figure 4-6 Flowchart for moving to the menu screen

4.2.4 Processing at touch keys operation

The flowchart for touch keys operation is shown below.

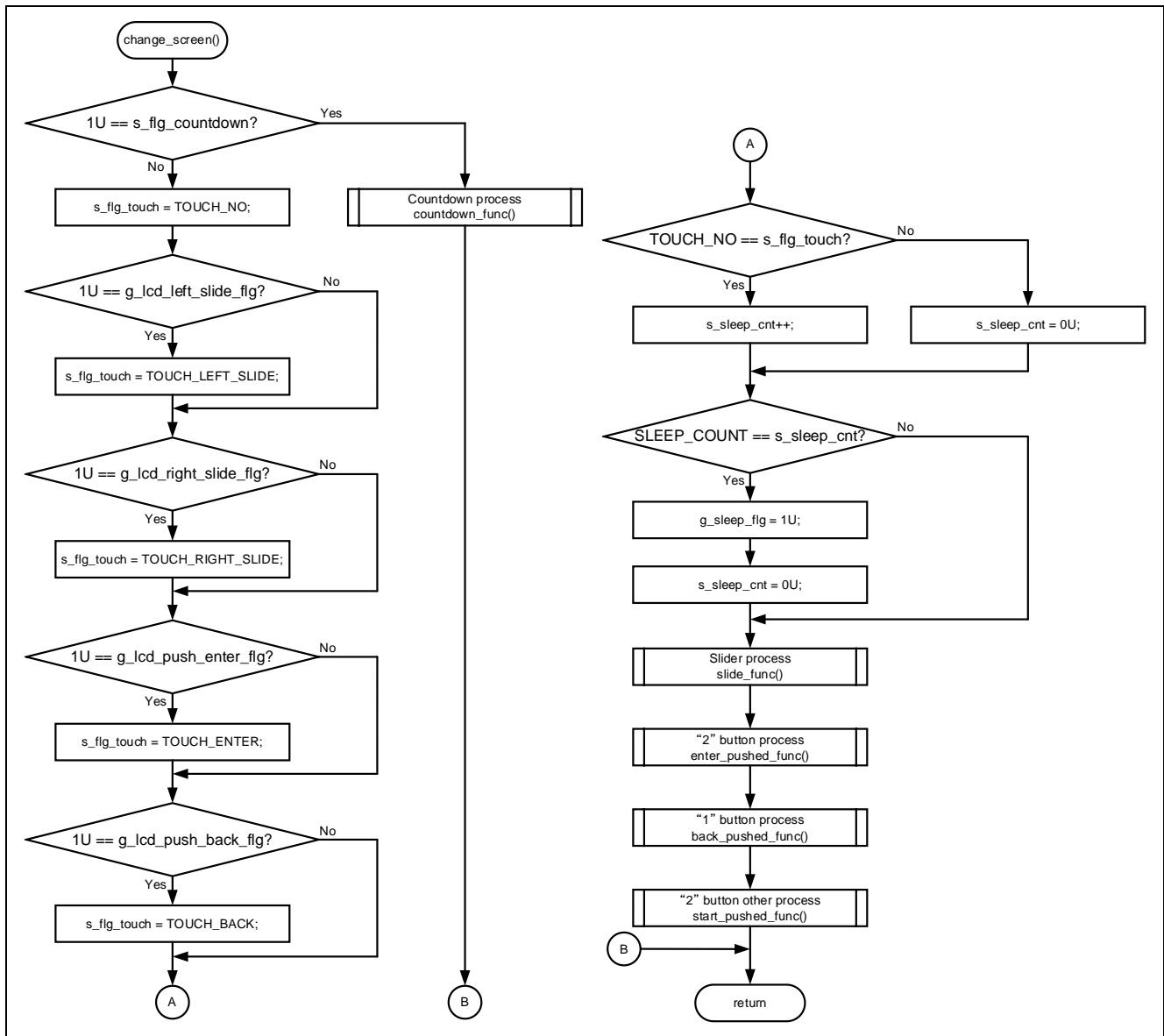

Figure 4-7 Flowchart for touch keys operation

4.2.5 Processing at touch slider operation

The flowchart for touch slider operation is shown below.

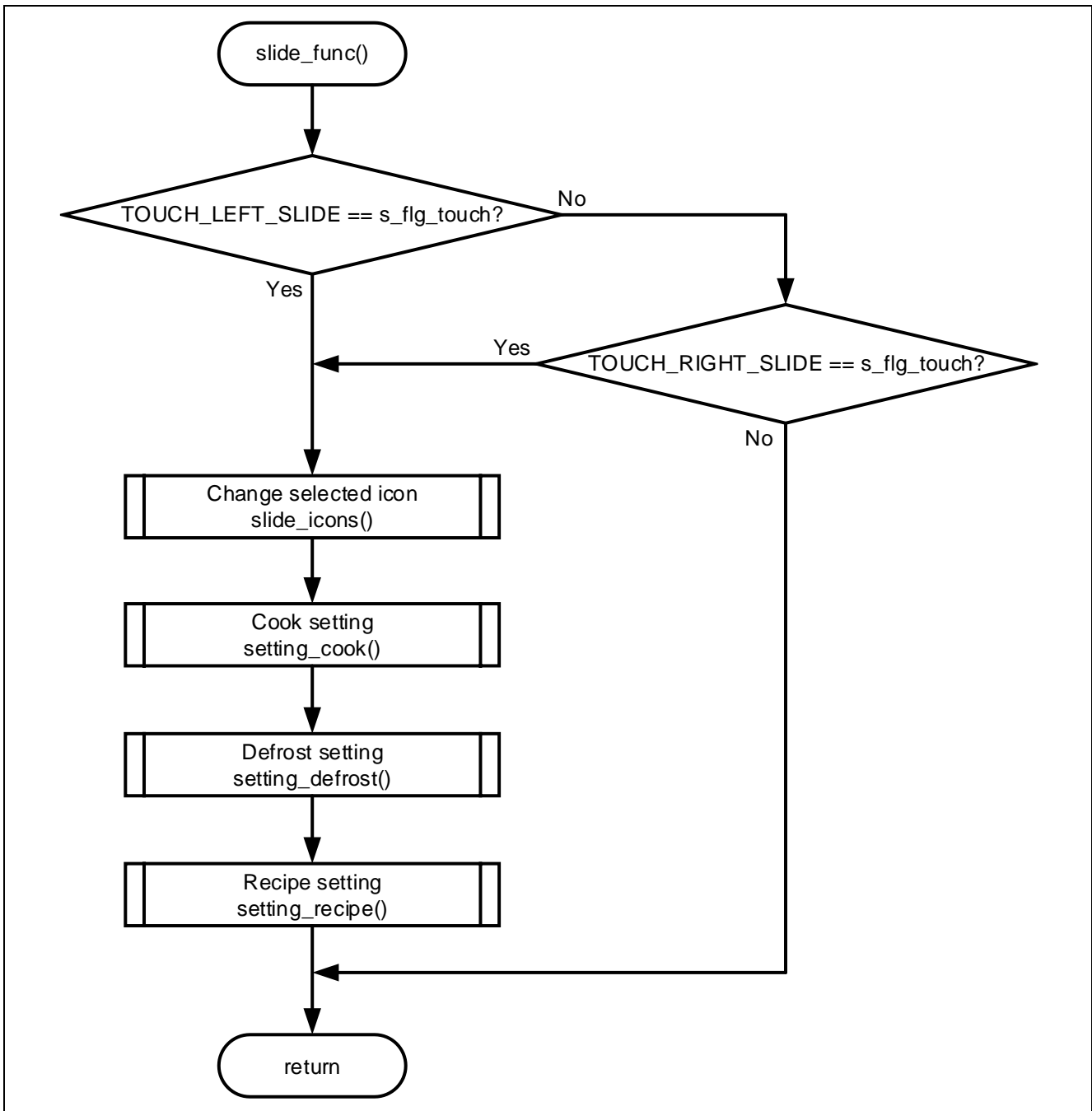

Figure 4-8 Flowchart for touch slider operation

4.2.6 Processing when the "1" button is touched

The flowchart when the "1" button is touched is shown below.

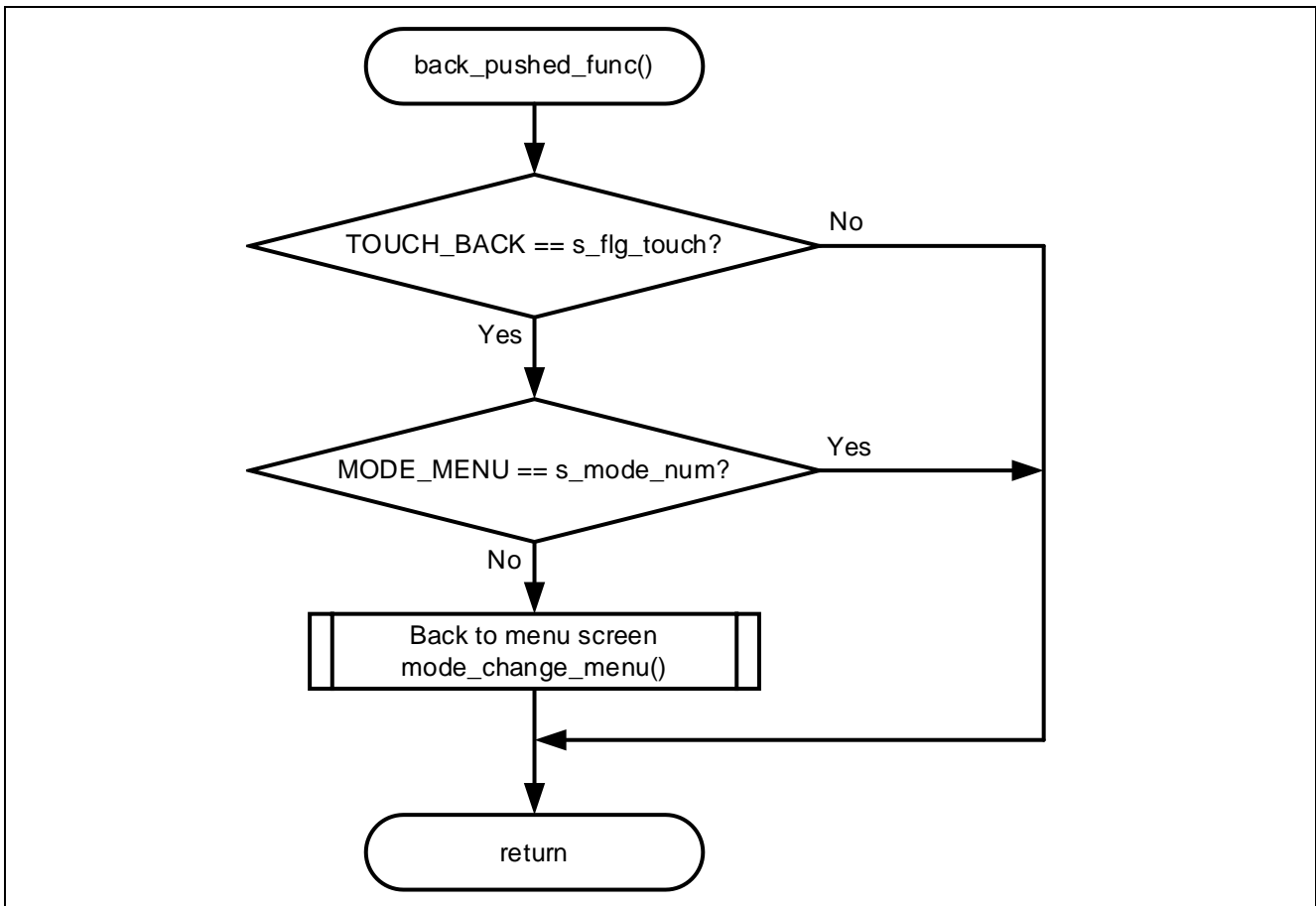

Figure 4-9 Flowchart when the "1" button is touched

4.2.7 Processing when the "2" button is touched (1)

The flowchart when the "2" button is touched is shown below.

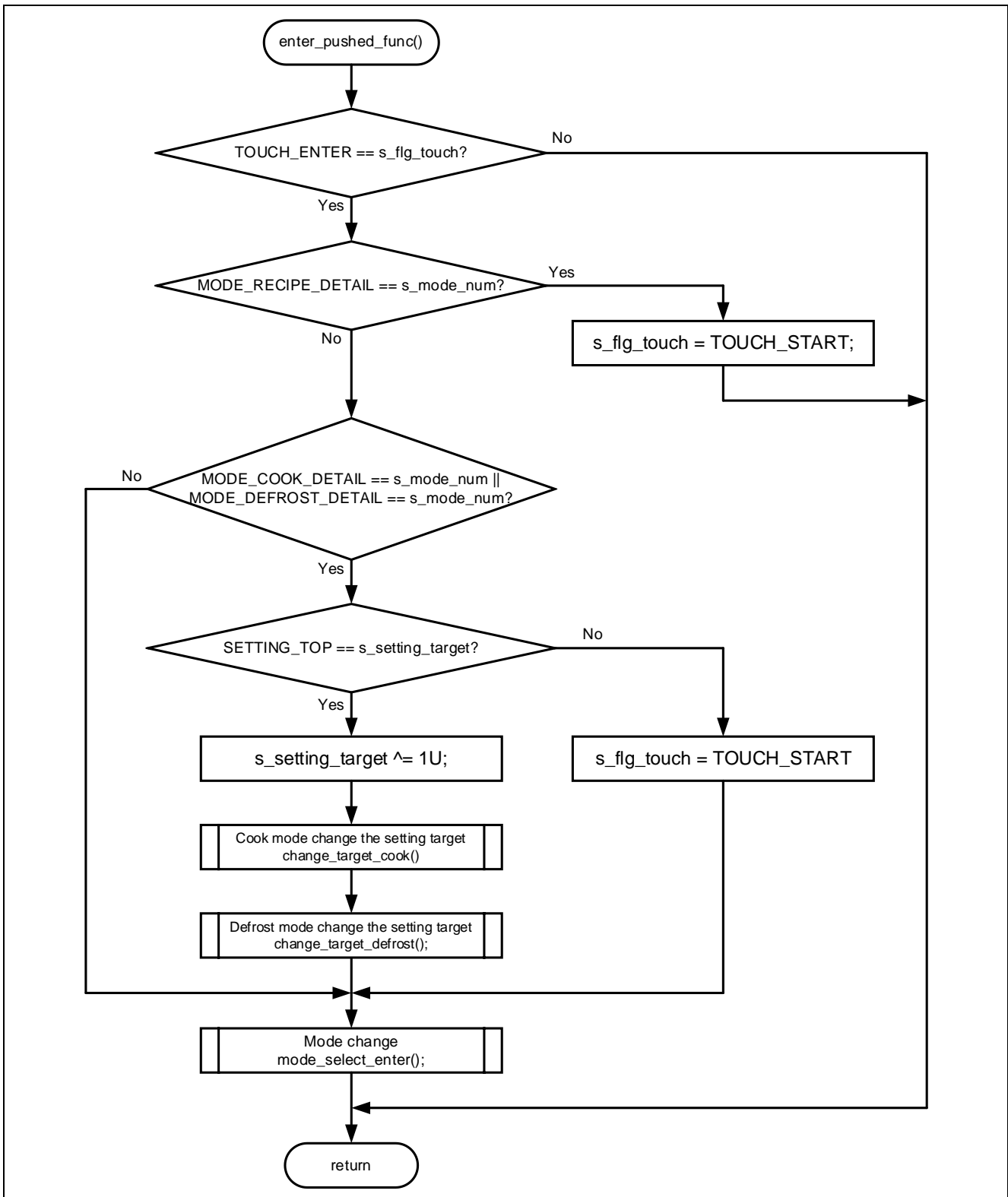

Figure 4-10 Flowchart when the "2" button is touched

4.2.8 Processing when the "2" button is touched (2)

The flowchart when the "2" button is touched is shown below.

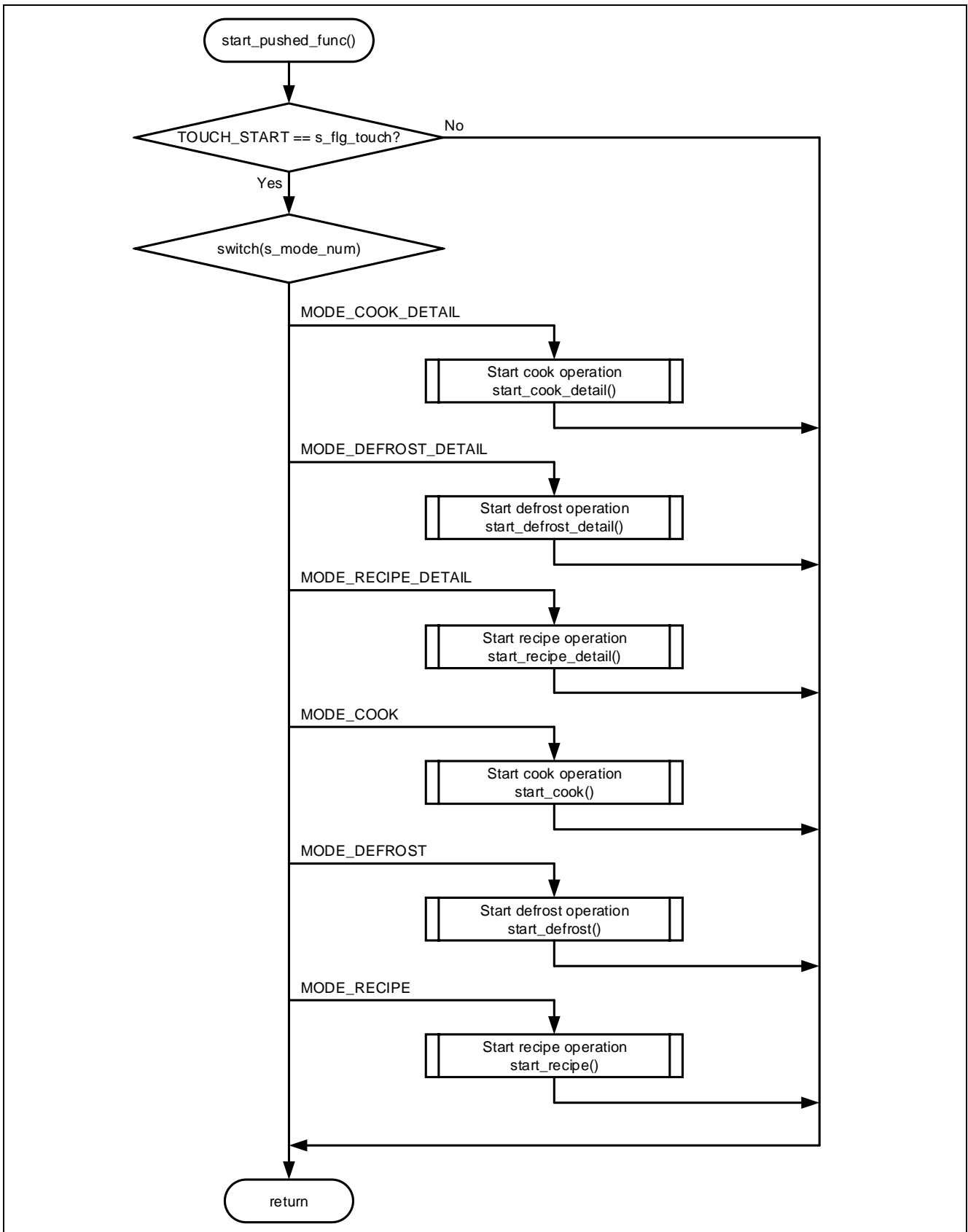

Figure 4-11 Flowchart when the "2" button is touched

4.2.9 Processing during cooking

The flowchart during cooking is shown below.

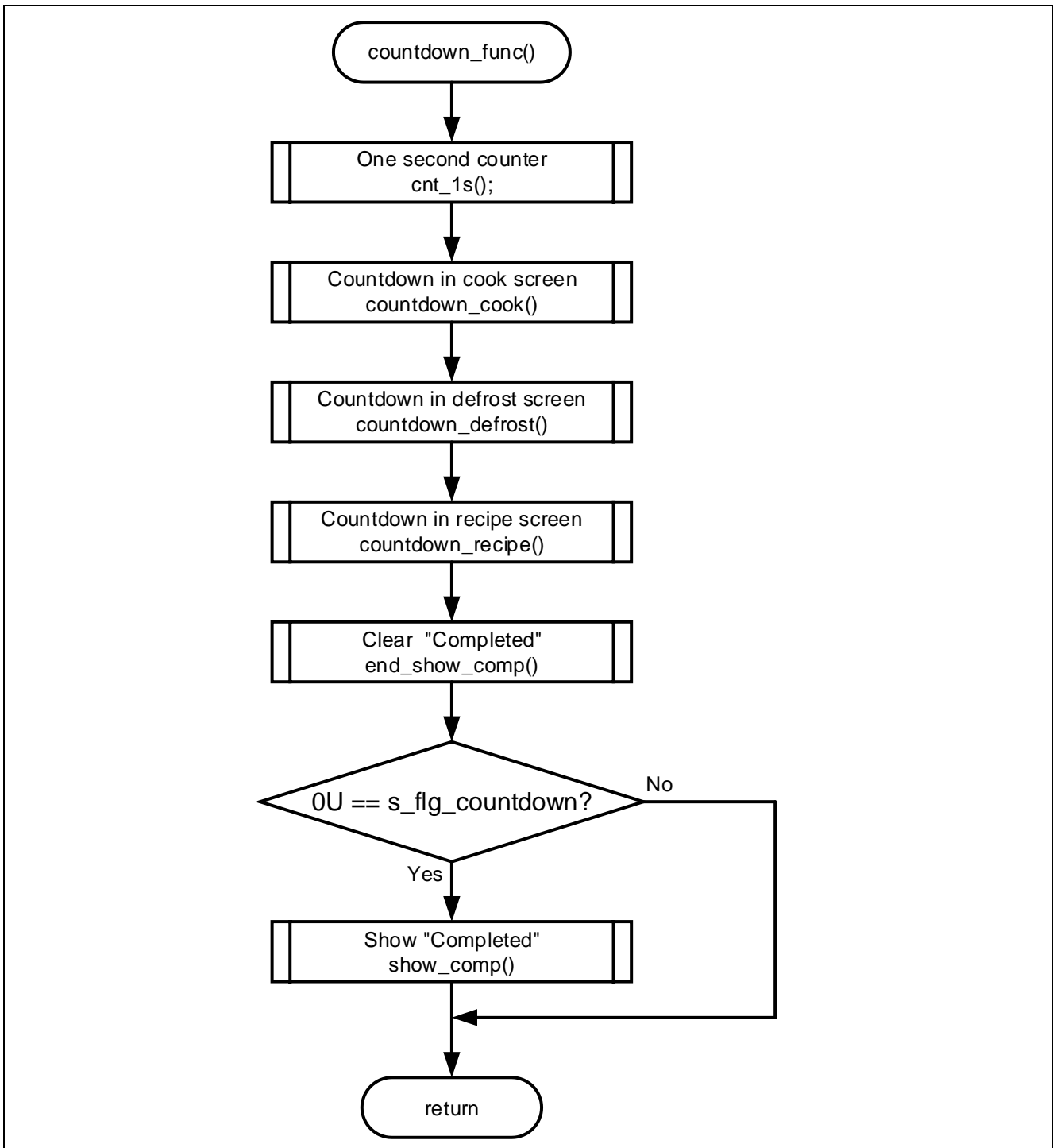

Figure 4-12 Flowchart during cooking

4.2.10 Overall flowchart of touch control

The overall flowchart of touch control is shown below.

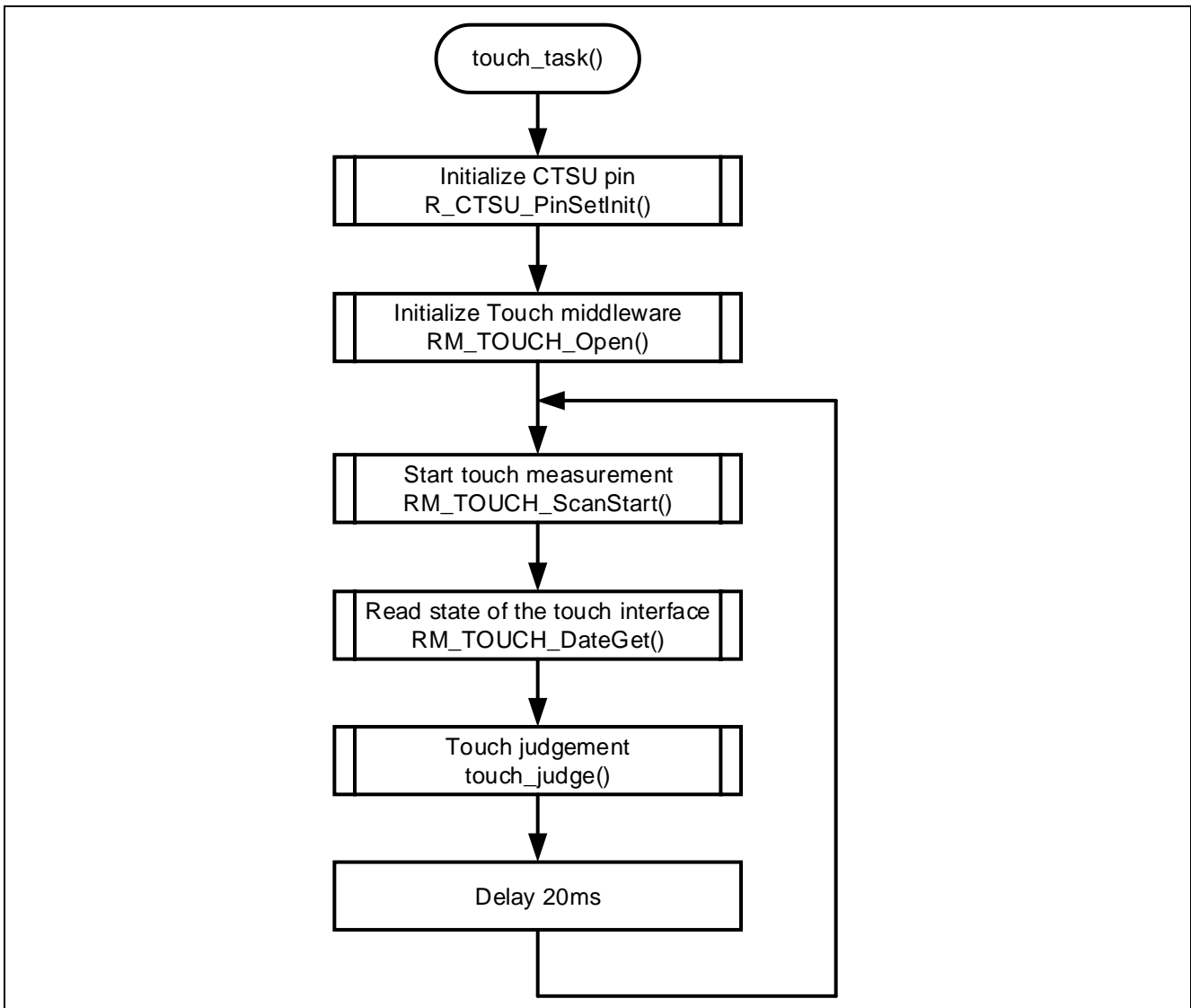

Figure 4-13 Overall flowchart of touch control

4.2.11 Processing of touch judgement

The flowchart of touch judgement is shown below.

If the left side of the touch slider is touched after touching the right side of the touch slider, the touch slider is judged to have slid to the left. The same is true on the opposite side.

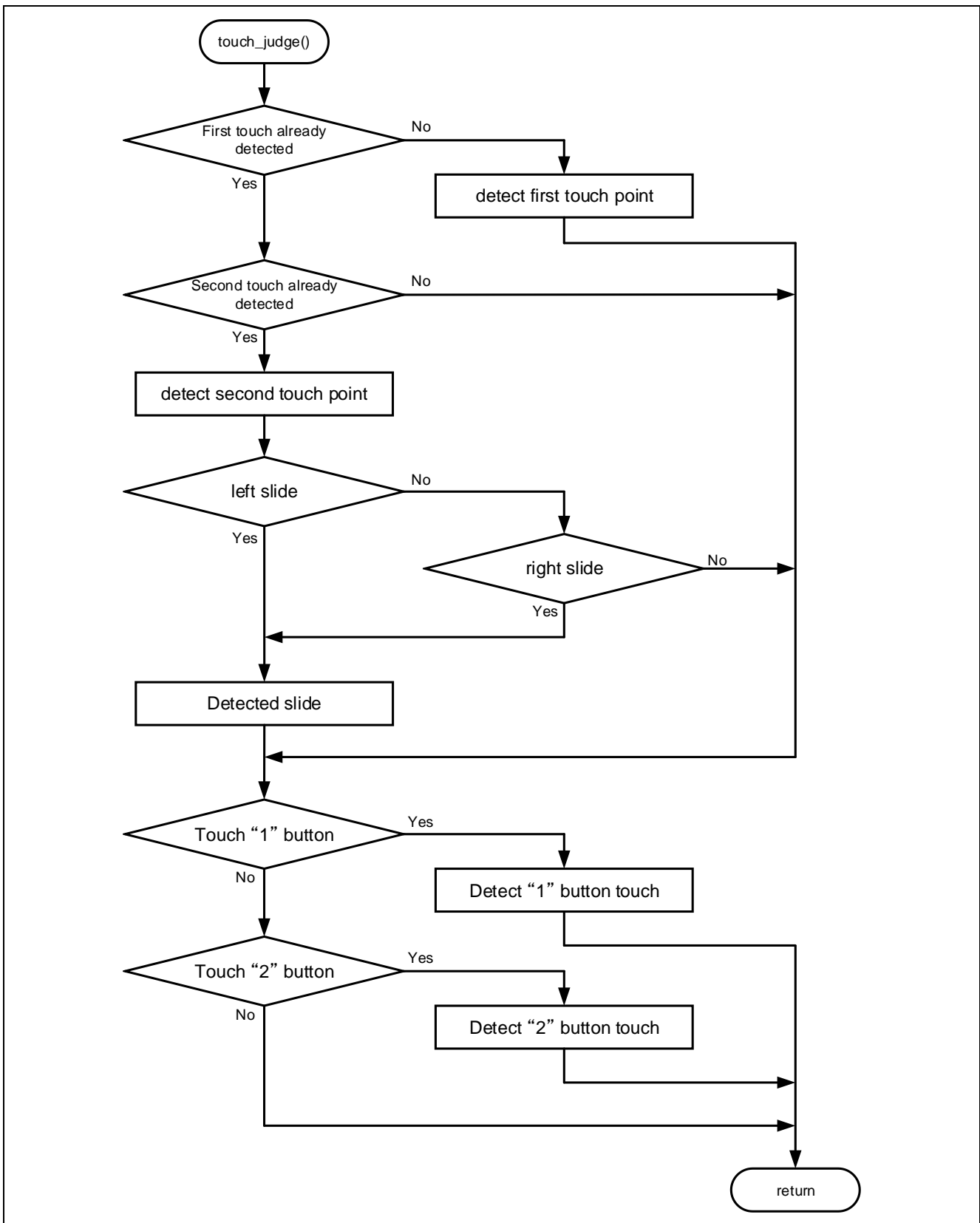

Figure 4-14 Flowchart of touch judgement

4.2.12 Processing of startup screen display

The flowchart of startup screen display is shown below.

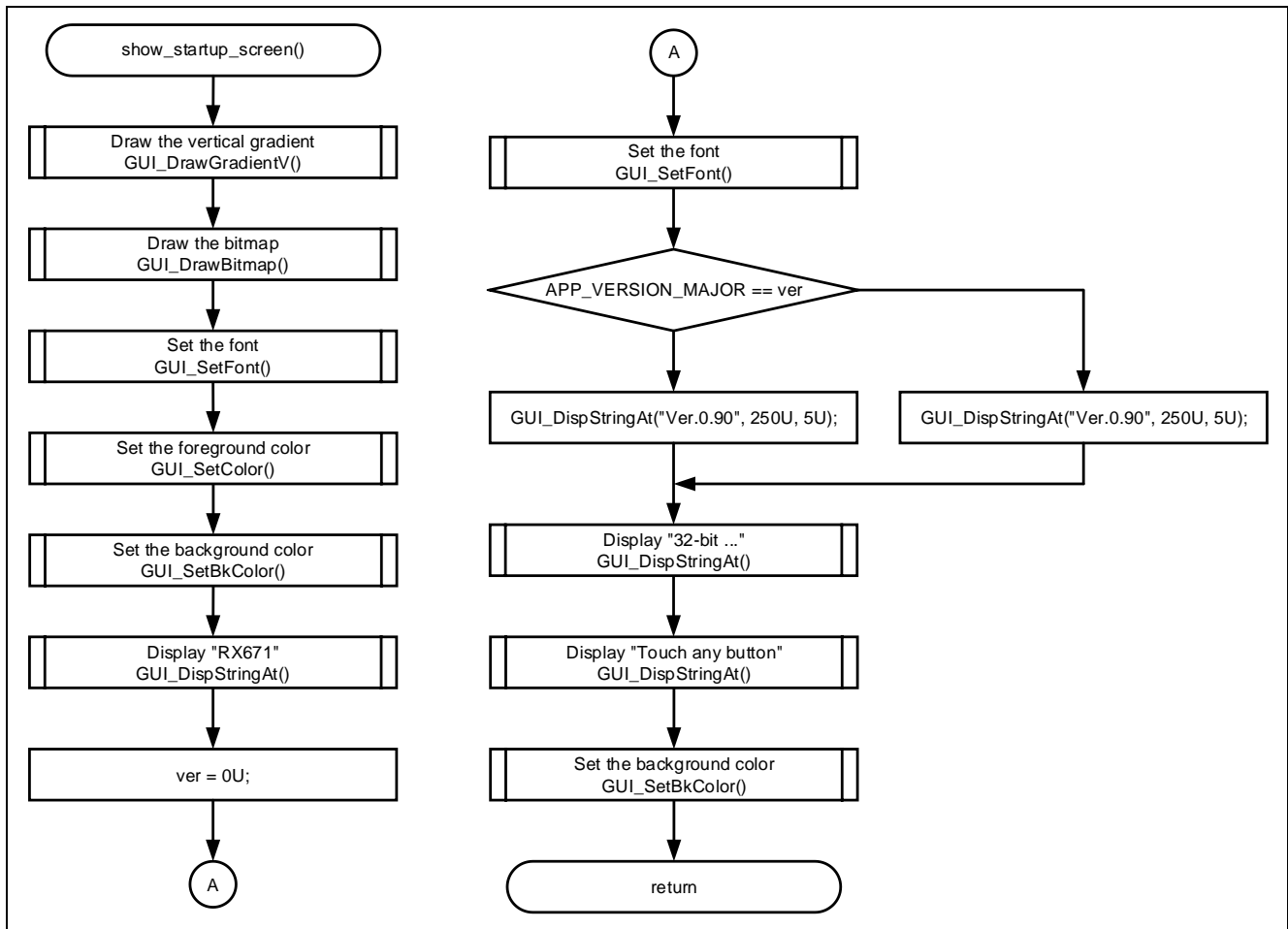

Figure 4-15 Flowchart of startup screen display

4.2.13 Processing of 5 seconds wait

The flowchart of 5 seconds wait is shown below.

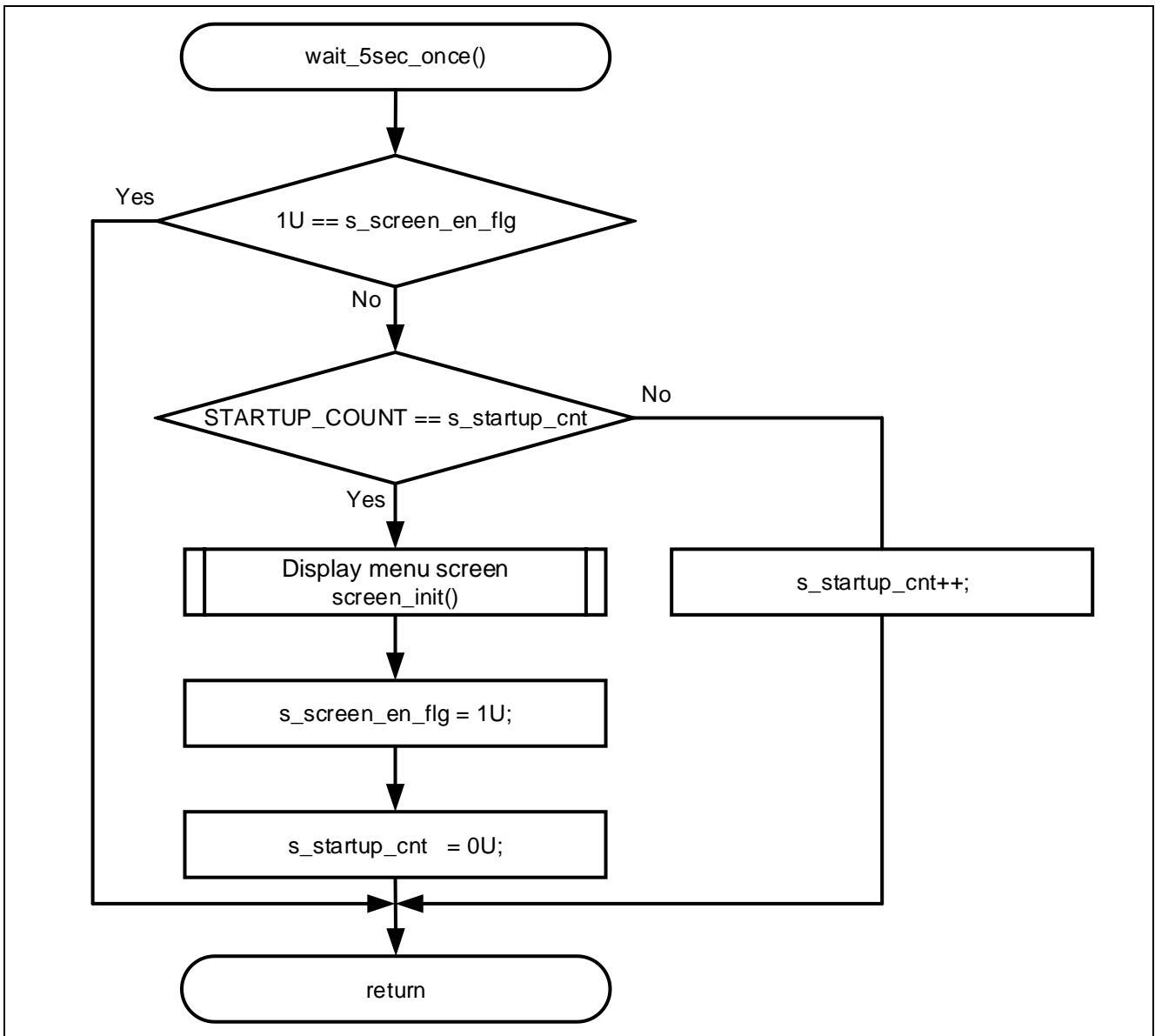

Figure 4-16 Flowchart of 5 seconds wait

4.2.14 Processing of flag clear for touch

The flowchart of flag clear for touch is shown below.

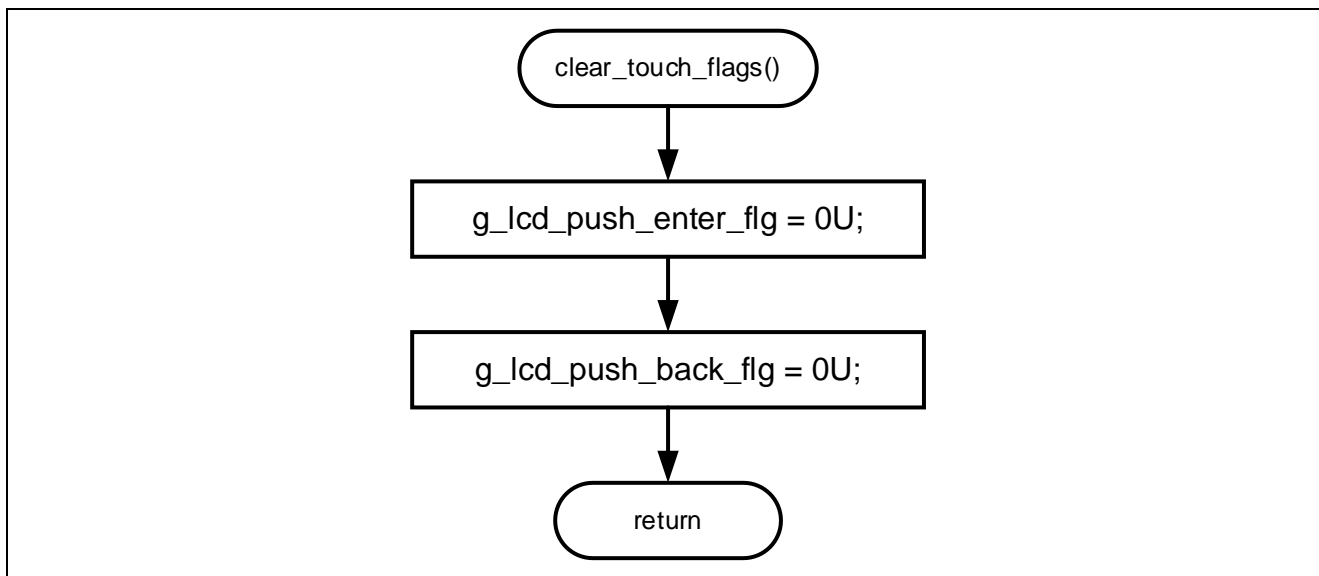

Figure 4-17 Flowchart of flag clear for touch

4.3 Pins Used

The following shows lists pins used in this sample program.

Table 4-1 List of Pins and Functions

Pin name	Input/Output	Function
P55/MISOC	Input	RSPI2 MISO pin
P54/MOSIC	Output	RSPI2 MOSI pin
P56/RSPCKC	Input/Output	RSPI2 clock pin
P33/RXD0	Input	UART0 receiving pin
P32/TXD0	Output	UART0 sending pin
P12/RXD2	Input	UART2 receiving pin
P13/TXD2	Output	UART2 sending pin
PJ5/CTS2	Input	CTS signal input pin
P86/RXD10	Input	UART10 receiving pin
P87/TXD10	Output	UART10 sending pin
P02/SCK6	Input/Output	SCI6 clock pin
P01/SMISO6	Input	SCI6 MISO pin
P00/SMOSI6	Output	SCI6 MOSI pin
PC4/TSCAP	-	TSCAP pin
P25/TS4	Input	Electrostatic capacitance measurement pin
P24/TS5	Input	Electrostatic capacitance measurement pin
P23/TS6	Input	Electrostatic capacitance measurement pin
P21/TS8	Input	Electrostatic capacitance measurement pin
P20/TS9	Input	Electrostatic capacitance measurement pin
P07/ADTRG0	Input	Trigger input pin
P40/AN000	Input	12bit A/D converter

4.4 Sample Program Structure

4.4.1 Peripheral Functions Used

The following shows lists peripheral functions used in this sample program.

Table 4-2 List of Peripheral Functions Used and Functions

Peripheral Functions	Functions
RSPI2	SPI Communication with LCD module
DMAC	Used for RAM to RSPI transfer
SCI0, SCI2, SCI10	UART communication with Wi-Fi module (2 systems)
S12AD0	Used for internal CTSU FIT
CTSU	Used for touch buttons and touch slider
CMT0	Used for internal emWin FIT
CMT2	Used for RTOS

4.4.2 Components Used

The following shows lists components used in this sample program.

Table 4-3 List of Components Used

Components	Abbreviation	Version
ADC Driver	r_s12ad_rx	5.00
AWS_device_shadow	AWS_device_shadow	1.0.110
AWS_ggd	AWS_ggd	1.0.110
AWS_mqtt	AWS_mqtt	1.0.110
AWS_secure_socket	AWS_secure_socket	1.0.110
AWS_tcp_ip	AWS_tcp_ip	1.0.110
Board Support Package	r_bsp	7.21
Byte-based circular buffer library	r_byteq	2.10
CMT driver	r_cmt_rx	5.40
CTSU QE API	r_ctsu_qe	2.20
DMAC driver	r_dmaca_rx	3.00
Flash API for RX100, RX200, RX600, and RX700	r_flash_rx	4.91
FreeRTOS_kernel	FreeRTOS_kernel	1.0.110
FreeRTOS_Object	FreeRTOS_Object	1.0.112
GPIO Driver	r_gpio_rx	4.70
Graphic Library with Graphical User Interface	r_emwin_rx	6.32.a.1.00
RSPI Driver	r_rsapi_rx	3.04
SCI Driver	r_sci_rx	4.60
Touch QE API	rm_touch_qe	2.20
Wi-Fi Module control functions for Renesas MCUs	r_wifi_sx_ulpn	1.16

4.4.3 Peripheral Function Settings

The Smart Configurator settings used in this sample program are shown below. The items and settings in each table in the Smart Configurator settings are described in the notation on the configuration screen.

Settings not listed are assumed to be default settings.

Table 4-4 Parameters of Smart Configurator (1/5)

Category	Item	Setting/Description
Smart Configurator >> Clock		The following settings are made on the "Clocks" Tab.
	VCC	3.3 (V)
	Main clock	Stopped: Unchecked.
	PLL circuit setting	Frequency Division: x1 Frequency Multiplication: x15
	HOCO clock	Operation: Checked. HOCO oscillation enabled after reset
	LOCO clock	Stopped: Unchecked.
	IWDT dedicated clock	Clock source: HOCO Flash IF clock (FCLK): 60MHz System clock (ICLK): 120MHz Peripheral module clock (PCLKA): 120MHz Peripheral module clock (PCLKB): 60MHz Peripheral module clock (PCLKC): 60MHz Peripheral module clock (PCLKD): 60MHz
Smart Configurator >> System		Debugging interfaces setting: FINE
Smart Configurator >> Components >> r_bsp		Other than the changes listed below, default settings are used.
	Heap size	0x4000
	ROM Cache Enable Register	Disabled
	Software Interrupt Unit2 (SWINT2)	Used
	Software Interrupt Task Buffer Number	8
	Initial value of the software interrupt priority	Priority level 1
	Serial terminal select	Enabled
	Channel for serial terminal	Channel 3
	Bitrate for serial terminal	115200
	Interrupt priority serial terminal	Priority level 3
	HOCO Trimming select	Disabled
Smart Configurator >> Components >> r_dmaca_rx		Default settings are used.
Smart Configurator >> Components >> r_ctsu_qe		Other than the changes listed below, default settings are used.
	TSCAP pin	Use: Checked.
	TS4 pin	Use: Checked.
	TS5 pin	Use: Checked.
	TS6 pin	Use: Checked.
	TS8 pin	Use: Checked.
	TS9 pin	Use: Checked.

Table 4-5 Parameters of Smart Configurator (2/5)

Category	Item	Setting/Description
Smart Configurator >> Components >> r_gpio_rx		Default settings are used.
Smart Configurator >> Components >> r_flash_rx		Other than the changes listed below, default settings are used.
	Enable code flash programming (FLASH_CFG_CODE_FLASH_ENABLE)	Includes code to program ROM area
	Enable BGO/Non-blocking data flash operations (FLASH_CFG_DATA_FLASH_BGO)	Enable BGO mode
	Enable BGO/Non-blocking code flash operations (FLASH_CFG_CODE_FLASH_BGO)	Enable BGO mode
	Enable code flash self-programming (FLASH_CFG_CODE_FLASH_RUN_FROM_ROM)	Programming code flash while executing from another segment in ROM
Smart Configurator >> Components >> r_rspi_rx		Other than the changes listed below, default settings are used.
	Dummy data of reception	0x00
	RSPI channel 0	Unused
	RSPI channel 2	Used
	Interrupt priority level of RSPI channel 2	Level 3
	RSPI2	Checked
	RSPCKC Pin	Use: Checked
	MOSIC Pin	Use: Checked
	MISOC Pin	Use: Checked
Smart Configurator >> Components >> r_sci_rx		Other than the changes listed below, default settings are used.
	Use SSPI (SCI_CFG_SSPI_INCLUDED)	Include
	Include software support for channel 0 (SCI_CFG_CH0_INCLUDED)	Include
	Include software support for channel 2 (SCI_CFG_CH2_INCLUDED)	Include
	Include software support for channel 10 (SCI_CFG_CH10_INCLUDED)	Include
	ASYNC mode TX queue buffer size for channel 2 (SCI_CFG_CH2_TX_BUFSIZ)	2048
	ASYNC mode TX queue buffer size for channel 10 (SCI_CFG_CH10_TX_BUFSIZ)	2048
	ASYNC mode RX queue buffer size for channel 2 (SCI_CFG_CH2_RX_BUFSIZ)	2048
	ASYNC mode RX queue buffer size for channel 10 (SCI_CFG_CH10_RX_BUFSIZ)	2048
	Resources >> SCI	
	SCI0	Checked.
	RXD0/SMISO0/SSCL0 Pin	Use: Checked.
	TXD0/SMOSI0/SSDA0 Pin	Use: Checked.
	SCI2	Checked
	RXD2/SMISO2/SSCL2 Pin	Use: Checked
	TXD2/SMOSI2/SSDA2 Pin	Use: Checked
	CTS2#/RTS2#/SS2# Pin	Use: Checked
	SCI10	Checked.
	RXD10/SMISO10/SSCL10 Pin	Use: Checked.
	TXD10/SMOSI10/SSDA10 Pin	Use: Checked.

Table 4-6 Parameters of Smart Configurator (3/5)

Category	Item	Setting/Description
Smart Configurator >> Components >> r_cmt_rx		Default settings are used.
Smart Configurator >> Components >> rm_touch_qe		Default settings are used.
Smart Configurator >> Components >> r_byteq		Default settings are used.
Smart Configurator >> Components >> r_wifi_sx_ulp gn		Other than the changes listed below, default settings are used.
	SCI Channel number for SX-ULPGN Initial Command Port for AT command communication (WIFI_CFG_SCI_CHANNEL)	2
	SCI Channel number for SX-ULPGN Second Command Port for AT command communication (WIFI_CFG_SCI_SECOND_CHANNEL)	0
	General-purpose port PDR register connected to the SX-ULPGN EN pin (WIFI_CFG_RESET_PORT)	PORT9
	Configure RTS Port No. for WIFI_CFG_SCI_CHANNEL (WIFI_CFG_RTS_PORT)	PORT5
	Configure RTS Pin No. for WIFI_CFG_SCI_CHANNEL (WIFI_CFG_RTS_PIN)	1
	Socket Receive buffer size (WIFI_CFG_SOCKETS_RECEIVE_BUFFER_SIZE)	1024
Smart Configurator >> Components >> r_emwin_rx		Other than the changes listed below, default settings are used.
	Configurations >> BasicSetting	
	Work area size for GUI	10000
	Horizontal LCD size	240
	Vertical LCD size	320
	Color depth	16 bit per pixel
	LCD orientation	ORIENTATION_CCW
	Configurations >> Select LCD Interface	
	LCD interface	LCD_IF_RSPI
	Configurations >> Select LCD Interface >> SPI Interface Setting	
	LCD interface channel number	2
	Select LCD Driver IC	LCD_DRV_IC_ILI9341
	Communication baud rate of LCD interface	30000000
	Use or unused display cache	Unuse: Unchcked
	Configurations >> Select LCD Interface >> LCD Interface Pin Setting	
	Use Display Signal Pin	Use Display Signal Pin
	Display Signal Pin	GPIO_PORT_7_PIN_2
	Use Backlight Pin	Use Backlight Pin
	Backlight Pin	GPIO_PORT_7_PIN_1
	Use Data/Command Pin	Use Data/Command Pin
	Data/Command Pin	GPIO_PORT_7_PIN_4
	Use Chip Select Pin	Use Chip Select Pin
	Chip Select Pin	GPIO_PORT_J_PIN_3
	Configurations >> Select Touch Interface	
	Use Touch function	Not use Touch function: Unchecked

Table 4-7 Parameters of Smart Configurator (4/5)

Category	Item	Setting/Description
Smart Configurator >> Components >> FreeRTOS_Kernel		Other than the changes listed below, default settings are used.
	The total amount of RAM available in the FreeRTOS heap	(size_t)(200U * 1024U)
	Tick vector	_CMT2_CMI2
Smart Configurator >> Components >> FreeRTOS_Object		Other than the changes listed below, default settings are used.
	Tasks	Initialize: kernel start Task Code: touch_task Task Name: touch_task Stack Size: 512 Task Handler: NULL Parameter: NULL Priority: 1
		Initialize: kernel start Task Code: emwin_task Task Name: emwin_task Stack Size: 512 Task Handler: NULL Parameter: NULL Priority: 1
Smart Configurator >> Components >> AWS_device_shadow		Default settings are used.
Smart Configurator >> Components >> AWS_ggd		Default settings are used.
Smart Configurator >> Components >> AWS_mqtt		Default settings are used.
Smart Configurator >> Components >> AWS_tcp_ip		Default settings are used.

Table 4-8 Parameters of Smart Configurator (5/5)

Category	Item	Setting/Description
Smart Configurator >> Pins >> Serial Communication Interface >> SCI0		Uncheck all settings except the following
	RXD0	Use: Checked. Terminal Assignment: Set P33
	TXD0	Use: Checked. Terminal Assignment: Set P32
Smart Configurator >> Pins >> Serial Communication Interface >> SCI2		Uncheck all settings except the following
	CTS2	Use: Checked. Terminal Assignment: Set PJ5
	RXD2	Use: Checked. Terminal Assignment: Set P12
	TXD2	Use: Checked. Terminal Assignment: Set P13
Smart Configurator >> Pins >> Serial Communication Interface >> SCI10		Uncheck all settings except the following
	RXD10	Use: Checked. Terminal Assignment: Set P86
	TXD10	Use: Checked. Terminal Assignment: Set P87

4.4.4 File Structure

The following shows file structure by sample program.

Table 4-9 File Structure

Folder name, File name	Outline
application_code	-
└ LCD	-
├ Resource	Folders for images and fonts
└ Source	-
├ LCD_custom_func.c	Source file for LCD related
└ LCD_custom_func.h	Header file for LCD related
renesas_code	-
├ frtos_startup	Generated folder for Amazon FreeRTOS
└ utility	
├ main_task.c	Amazon FreeRTOS main task
└ frtos_skeleton	-
├ emwin_task.c	Task for emWin control
├ task_function.h	Include file for emwin_task.c, touch_task.c
└ touch_task.c	Task for touch control
touch	-
├ touch_func.c	Source file for touch related
└ touch_func.h	Header file for touch related
qe_gen	Generated folder for QE for capacitive touch
└ main.c	Source file for main processing
config_files	Generated folder for Amazon FreeRTOS
demos	
freertos_kernel	
libraries	
QE-Touch	
vendors	Generated folder for Amazon FreeRTOS
└ renesas	-
└ boards	-
└ rx671-rsk	-
└ aws_demos	-
└ src	-
└ smc_gen	Smart Configurator generation
├ general	
├ r_cmt_rx	
├ r_config	
├ r_ctsu_qe	
├ r_dmaca_rx	
├ r_emwin_rx	
├ r_gpio_rx	
├ r_pincfg	
├ r_rsipi_rx	
└ rm_touch_qe	

4.4.5 Variables

The following shows the variables that are used in this sample program.

Table 4-10 List of variables used in the sample code

Variable name	Type	Contents
g_sleep_flg	uint8_t	Flag indicating LCD sleep state
g_button_status	uint64_t	Touch button status
g_slider_position	uint16_t	Touch position of the touch slider
g_lcd_left_slide_flg	uint8_t	Flag indicating that touch slider is slid to the left
g_lcd_right_slide_flg	uint8_t	Flag indicating that touch slider is slid to the right
g_lcd_push_enter_flg	uint8_t	Flag indicating that "2" button was touched.
g_lcd_push_back_flg	uint8_t	Flag indicating that "1" button was touched.
s_screen_en_flg	uint8_t	Flag indicating initial screen status
s_flg_countdown	uint8_t	The countdown is in progress on the LCD flag
s_flg_touch	uint8_t	Touch buttons status
s_startup_cnt	uint8_t	Counter for initial screen display time management
s_sleep_cnt	uint16_t	Counter for no-operation time management
s_mode_num	uint8_t	Mode status
s_setting_target	uint8_t	Flags indicating screen status

4.4.6 Constants

The following shows the constants that are used in this sample program.

Table 4-11 List of constants used in the sample code

Constant Name	Setting Value	Contents
LCD_BACKLIGHT	(PORT7.PODR.BIT.B1)	Pin to control LCD backlight
OFF	(0U)	Value at backlight off
ON	(1U)	Value at backlight on
TOUCH_NO	(0U)	Value at no-operation
TOUCH_LEFT_SLIDE	(4U)	Value indicating that touch slider is slid to the left
TOUCH_RIGHT_SLIDE	(3U)	Value indicating that touch slider is slid to the right
TOUCH_ENTER	(1U)	Value indicating that "2" button was touched
TOUCH_BACK	(2U)	Value at moving to the previous screen
SLEEP_COUNT	(SLEEP_TIME / DELAY_TIME)	When the counter in the program equals this value, the LCD is turned off
MODE_RECIPES_DETAIL	(6U)	Value of detail setting in Recipe mode
MODE_COOK_DETAIL	(3U)	Value of detail setting in Cook mode
MODE_DEFROST_DETAIL	(4U)	Value of detail setting in Defrost mode
MODE_COOK	(1U)	Value of start cooking in Cook mode
MODE_DEFROST	(2U)	Value of start cooking in Defrost mode
MODE_RECIPES	(5U)	Value of start cooking in Recipe mode
TOUCH_START	(5U)	Value of execution in each mode
SETTING_TOP	(0U)	Value of initial screen
MODE_MENU	(0U)	Value of mode not selected
APP_VERSION_MAJOR	(1U)	Version display
STARTUP_COUNT	(STARTUP_TIME / DELAY_TIME)	Display the initial screen until the counter in the program equals this value

4.4.7 Functions

The following shows the functions that are used in this sample program.

Table 4-12 List of functions used in the sample code

Function name	Outline
emwin_task	LCD Control
GUI_Init	Initializing emWin
screen_init	Menu screen is displayed on LCD
change_screen	LCD screen update
slide_func	Processing at touch slider operation
enter_pushed_func	Processing when "2" button is touched
back_pushed_func	Processing when "1" button is touched
start_pushed_func	Processing when "2" button is touched
countdown_func	Processing the countdown
slide_icons	Processing of cursor movement on menu screens and mode selection screens for Cook, Defrost and Recipe
setting_cook	Setting the number of watts and seconds in Cook mode
setting_defrost	Setting the level of defrosting and the number of grams in Defrost mode
setting_recipe	Setting the number of cupcakes in Recipe mode
mode_select_enter	Change the mode and display the LCD screen according to the mode
change_target_cook	Change the setting target of the detail setting screen in Cook mode
change_target_defrost	Change the setting target of the detail setting screen in Defrost mode
mode_change_menu	Move to the menu screen
start_cook	Start cooking in Cook mode
start_defrost	Start defrosting in Defrost mode
start_recipe	Start cooking in Recipe mode
countdown_cook	Processing during cooking in Cook mode
countdown_defrost	Processing during defrosting in Defrost mode
countdown_recipe	Processing during cooking in Recipe mode
touch_task	Initializing CTSU and calling the touch judgement function
touch_judge	Touch judgement
show_startup_screen	Processing of startup screen display
wait_5sec_once	Processing of 5 seconds wait
clear_touch_flags	Processing of flag clear for touch
start_cook_detail	Start of detail setting in Cook mode
start_defrost_detail	Start of detail setting in Defrost mode
start_recipe_detail	Start of detail setting in Recipe mode
cnt_1s	Processing of 1 second count
end_show_comp	Processing of cooking completion screen wait
show_comp	Processing of cooking completion screen display
set_icons	Processing of screen display for each mode
draw_choices_v09	Processing of version 0.90 display
draw_choices	Processing of version 1.00 display

4.4.8 Function Specifications

The following shows function specifications that are used in this sample program.

[Function name] emwin_task

Outline	LCD Control
Header	task_function.h
Declaration	void touch_task (void * pvParameters)
Description	Initializes emWin FIT and controls LCD.
Arguments	pvParameters
Return value	None
Remarks	None

[Function name] GUI_Init

Outline	Initializing emWin
Header	GUI.h
Declaration	void GUI_Init (void)
Description	Initializes emWin's internal data structures and variables.
Arguments	None
Return value	None
Remarks	None

[Function name] screen_init

Outline	Menu screen is displayed on LCD
Header	LCD_custom_func.h
Declaration	void screen_init (void)
Description	Menu screen is displayed on LCD.
Arguments	None
Return value	None
Remarks	None

[Function name] change_screen

Outline	LCD screen update
Header	LCD_custom_func.h
Declaration	void change_screen (void)
Description	Updates the LCD screen by touch operation.
Arguments	None
Return value	None
Remarks	None

[Function name] show_startup_screen

Outline	Processing of startup screen display
Header	LCD_custom_func.h
Declaration	void show_startup_screen (void)
Description	Performs startup screen display.
Arguments	None
Return value	None
Remarks	None

[Function name] touch_task

Outline Initializing CTSU and calling the touch judgement function
Header task_function.h
Declaration void touch_task(void * pvParameters)
Description Initializes CTSU and calls the touch judgement function
Arguments * pvParameters
Return value None
Remarks None

[Function name] touch_judge

Outline Touch judgement
Header touch_func.h
Declaration void touch_judge (uint64_t button_status, uint16_t slider_position)
Description Performs touch judgement and sets the judgement result to a flag.
Arguments button_status, slider_position
Return value None
Remarks None

4.4.9 ROM/RAM usage

ROM/RAM usage for this sample program is shown below.

Table 4-13 ROM usage

Size(KByte)	Description
550	Amazon FreeRTOS
200	LCD Graphic data
110	emWin, LCD control
15	demo program, LCD_custom_func
27	Other
Total 902KByte	MAX 1024KByte (88% Used) : 1024KByte x 2Bank

Table 4-14 RAM usage

Size(KByte)	Description
200	OS Heap area
16	Heap area
74	AWS demo program
37	AWS cloud (exp. OTA)
11	emWin
18	Other
Total 356KByte	MAX 384KByte (92.7% Used)

5. Importing a Project

The sample program is distributed in e² studio project format. This section shows how to import a project into e² studio or CS+. After importing a project, check the build and debug settings.

5.1 Procedure in e² studio

To use sample programs in e² studio, follow the steps below to import them into e² studio. In projects managed by e² studio, do not use space codes, multibyte characters, and symbols such as "\$", "#", "%" in folder names or paths to them.

(Note that depending on the version of e² studio you are using, the interface may appear somewhat different from the screenshots below.)

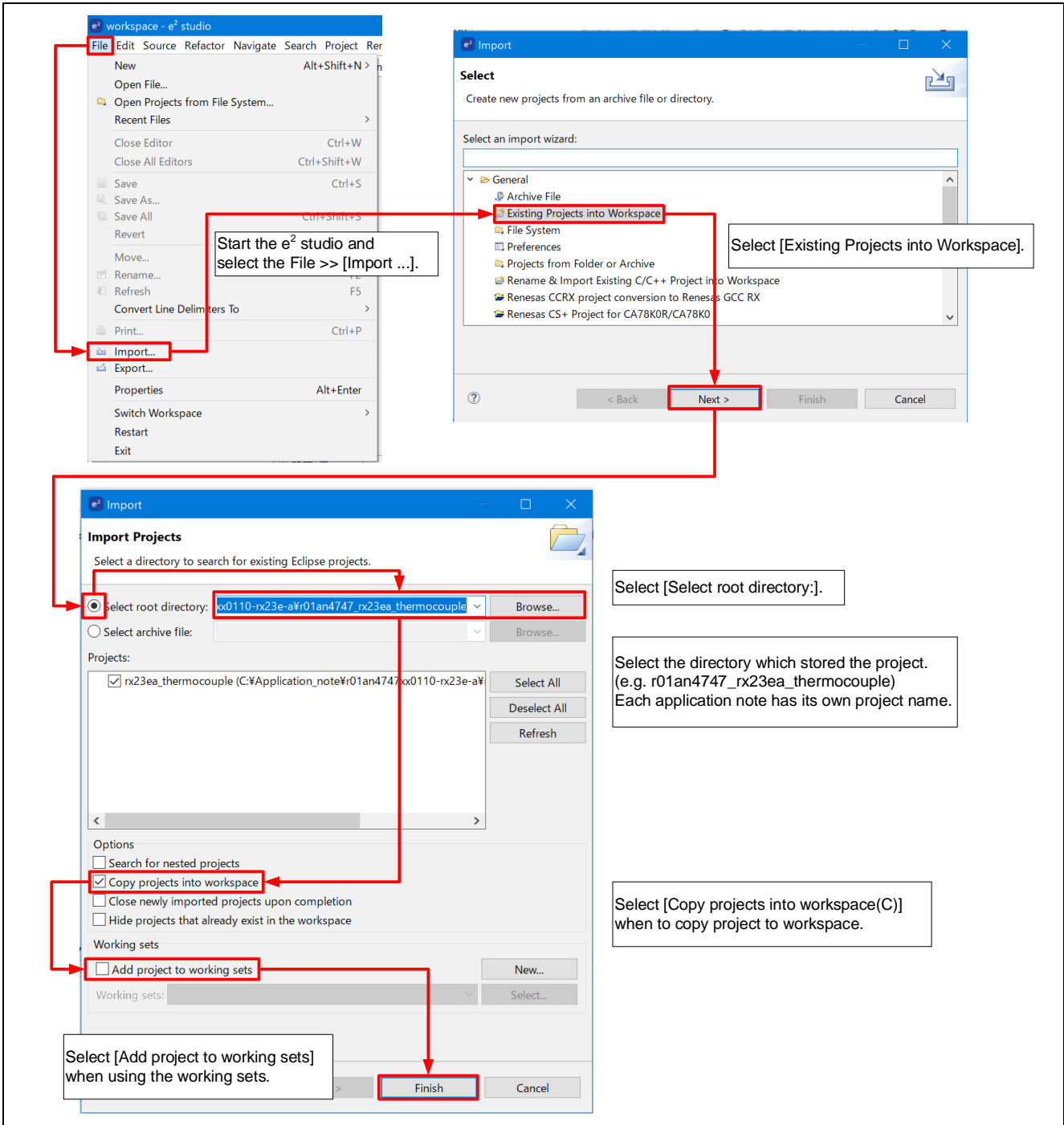

Figure 5-1 Import a Project into e² Studio

5.2 Procedure in CS+

To use sample programs in CS+, follow the steps below to import them into CS+. In projects managed by CS+, do not use space codes, multibyte characters, and symbols such as "\$", "#", "%" in folder names or paths to them.

(Note that depending on the version of CS+ you are using, the interface may appear somewhat different from the screenshots below.)

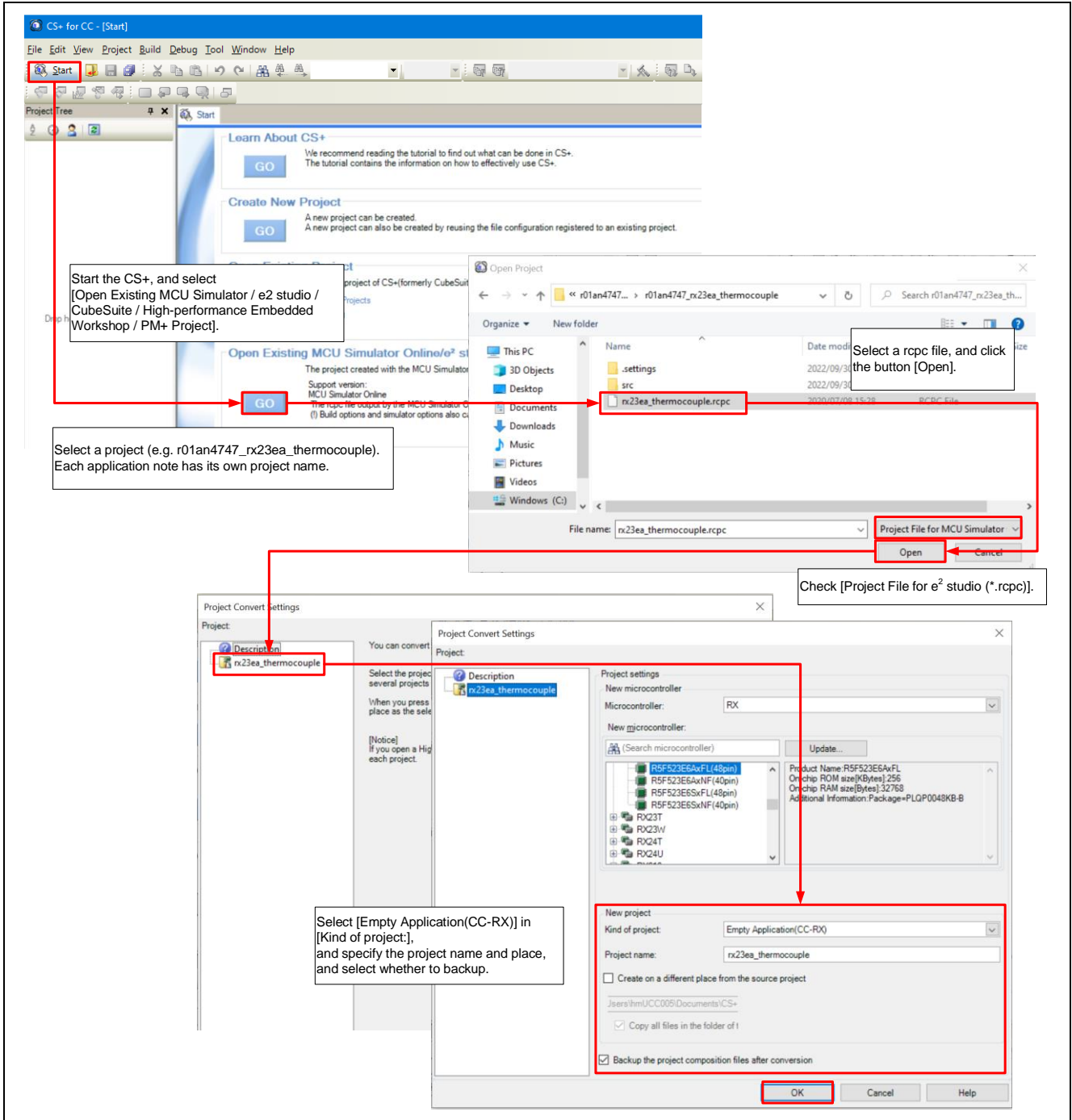

Figure 5-2 Importing a Project into CS+

6. Start Demonstration

Disconnect the E2 Emulator Lite and turn on Renesas Starter Kit+ for RX671 to start the demonstration program. This demonstration program assumes control of the display and settings of a microwave oven. Set the cooking conditions and recipe selections using the touch buttons and touch slider while checking the LCD.

Hereinafter, touch buttons are described as buttons and touch slider is described as slider.

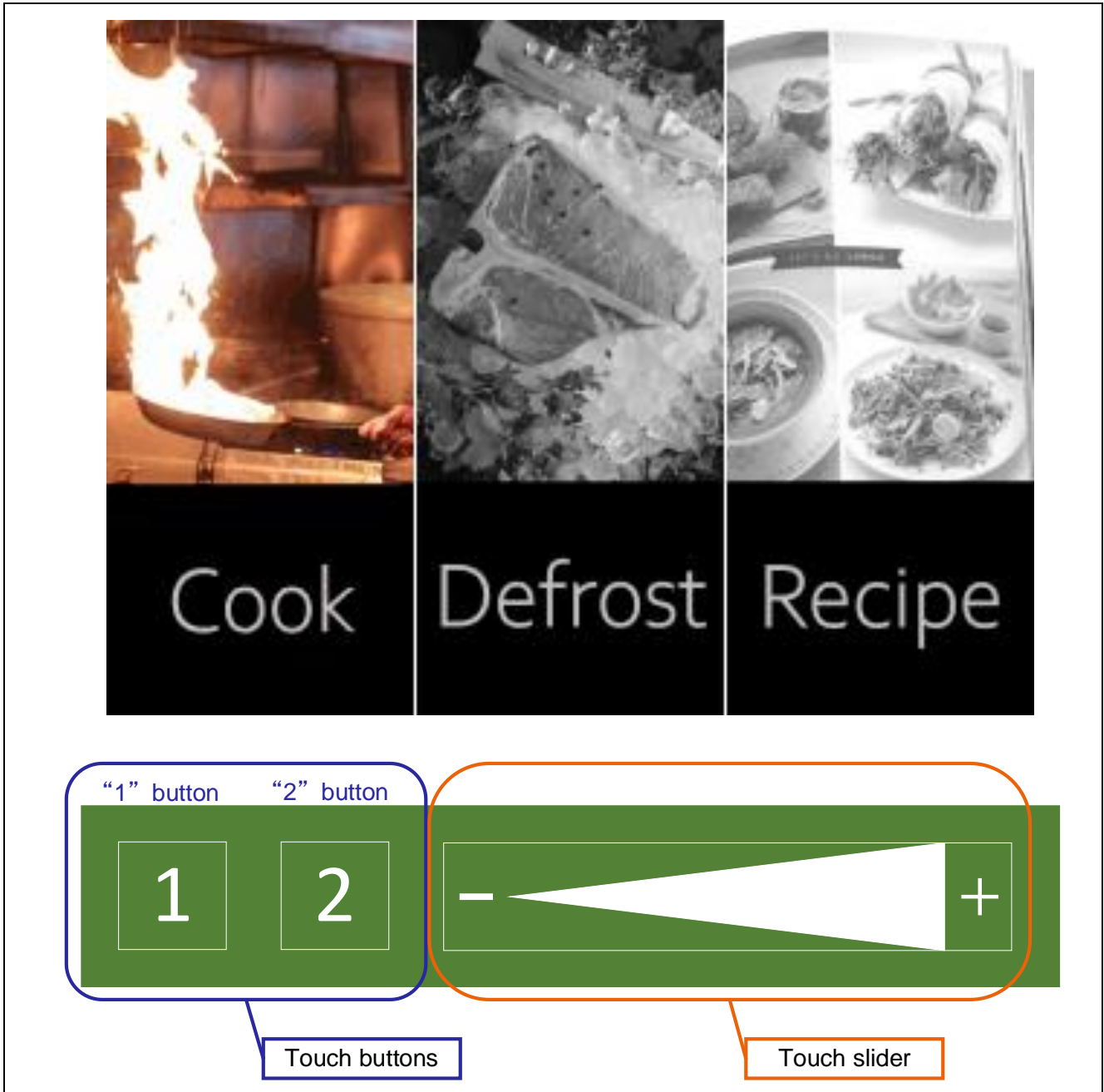

Figure 6-1 Demonstration screen and operation panel

6.1 Powered on Renesas Starter Kit+ for RX671 and menu screen

When Renesas Starter Kit+ for RX671 is powered on, the LCD panel displays the RX logo and RX671 features (initial screen) for approximately 5 seconds. When the display finishes, the sample program starts and becomes a menu screen.

And while the initial screen is displayed, can immediately move to the menu screen by touching one of the buttons.

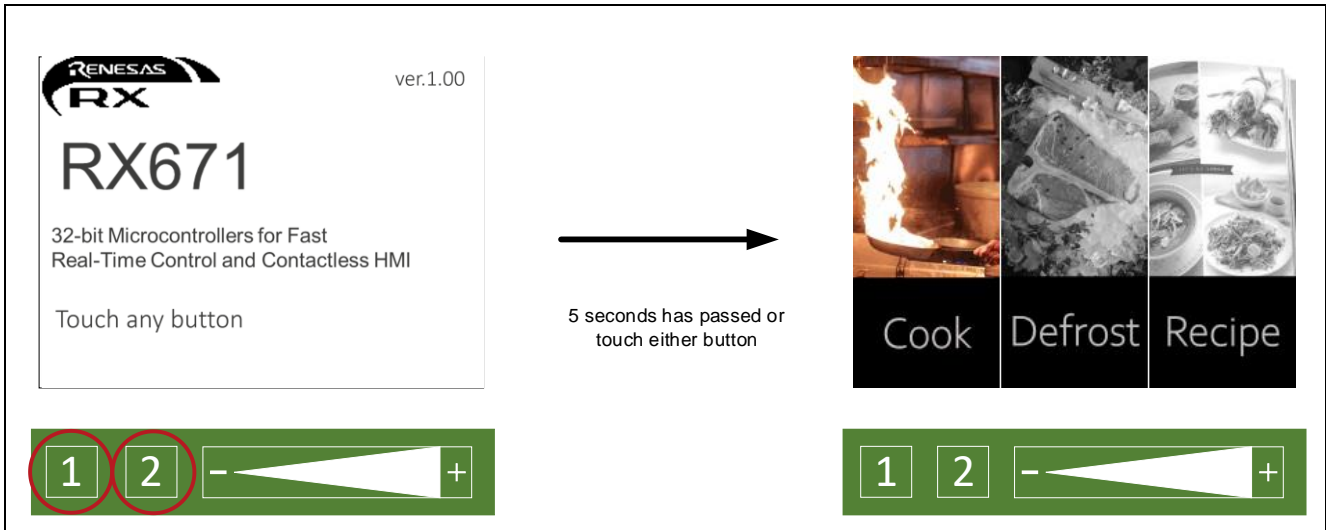

Figure 6-2 Start of the demonstration

6.2 Menu screen

"Cook", "Defrost" or "Recipe" can be selected with the slider operation on the menu screen.



Figure 6-3 How to operate the menu screen

6.3 Cook setting

6.3.1 Move to mode selection screen

While "Cook" is selected on the menu screen, touching the "2" button can move to the Cook mode selection screen.

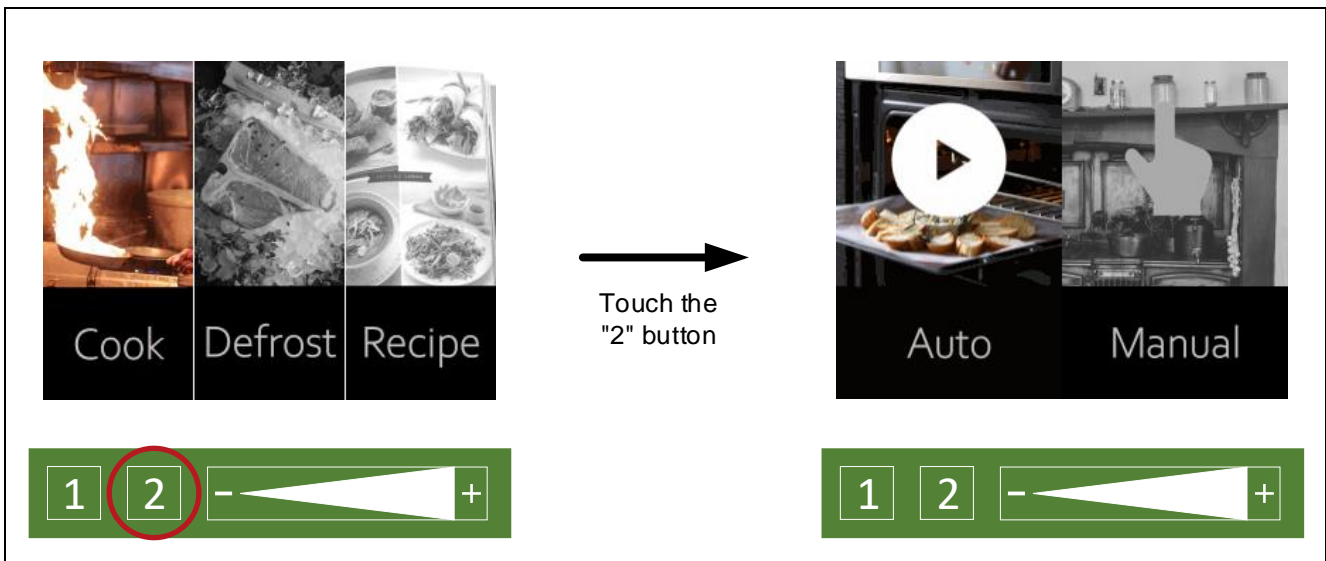

Figure 6-4 Move to the Cook mode selection screen

6.3.2 Select mode

While the Cook mode selection screen is displayed, "Auto" or "Manual" can be selected with the slider operation.

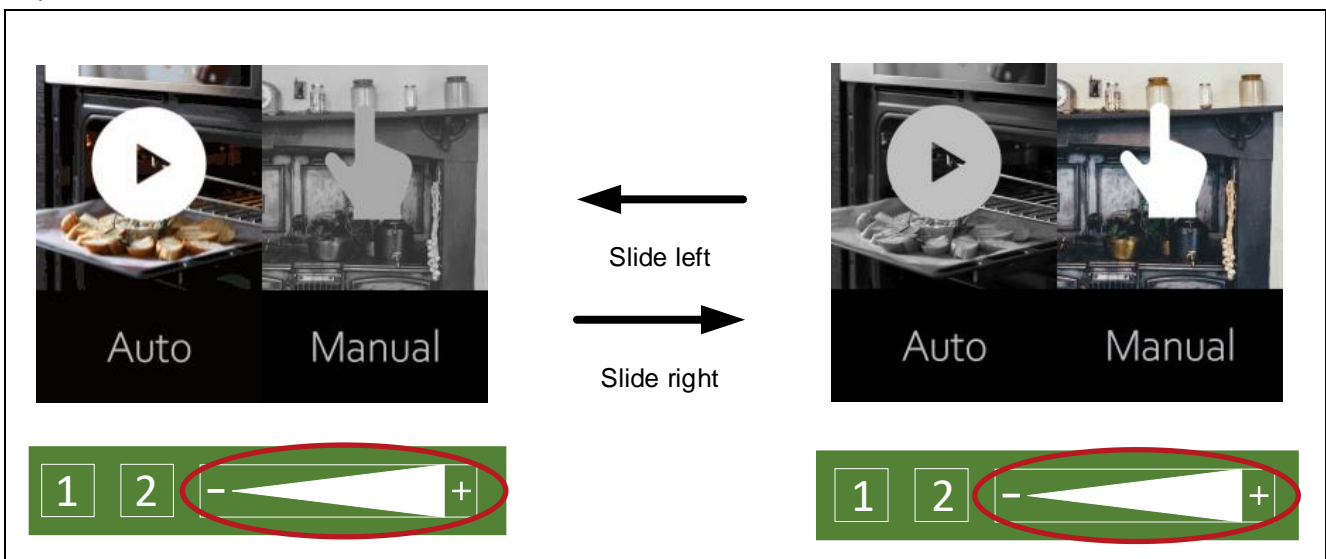

Figure 6-5 How to operate the Cook mode selection screen

6.3.3 Select Auto

While "Auto" is selected on the Cook mode selection screen, touching the "2" can start cooking.

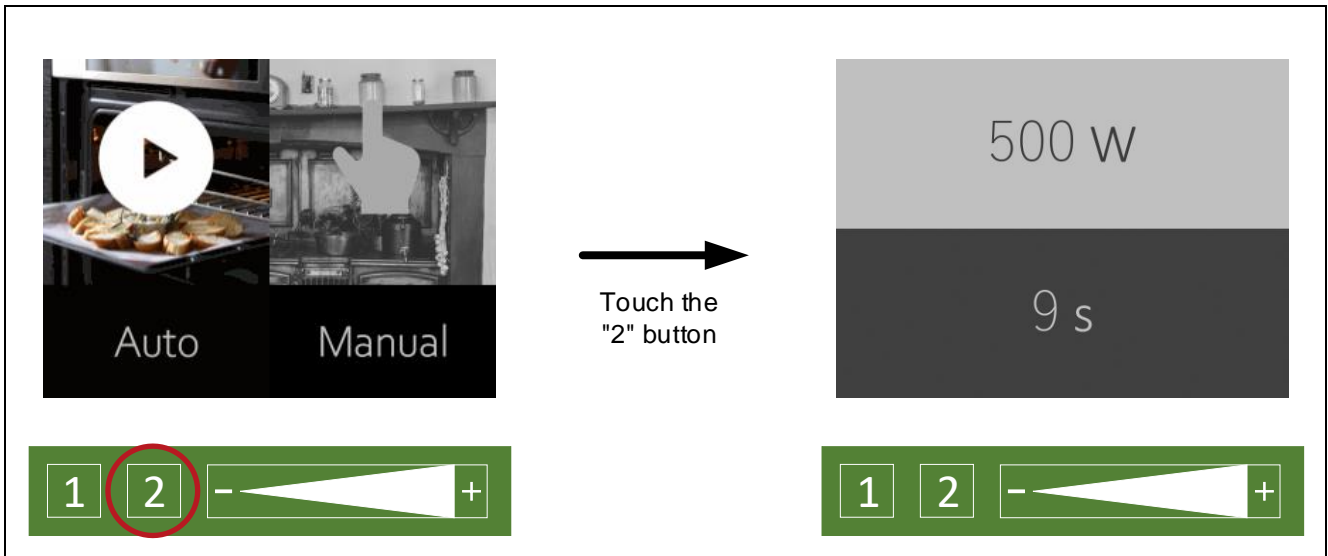

Figure 6-6 Start cooking in Auto mode

6.3.4 Select Manual

While "Manual" is selected on the Cook mode selection screen, touching the "2" button can move to the Cook detail setting screen.

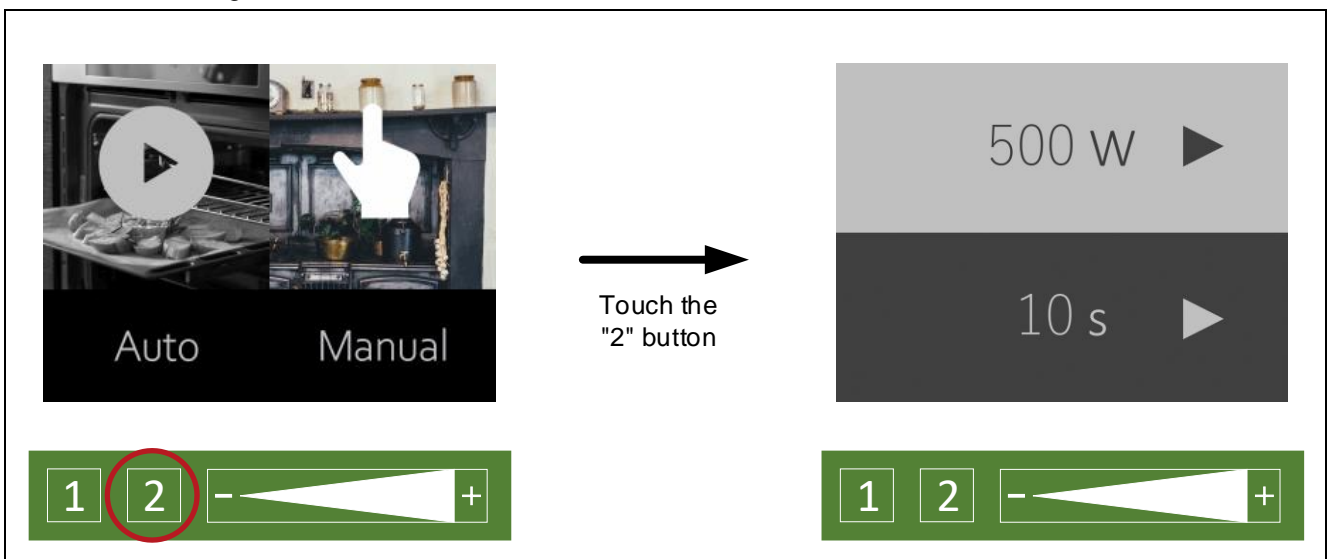

Figure 6-7 Move to the Cook detail setting screen

6.3.4.1 Set the number of watts

While the cursor is on the upper side, the number of watts can be set with the slider. "500W", "600W" and "700W" can be selected as the power level.

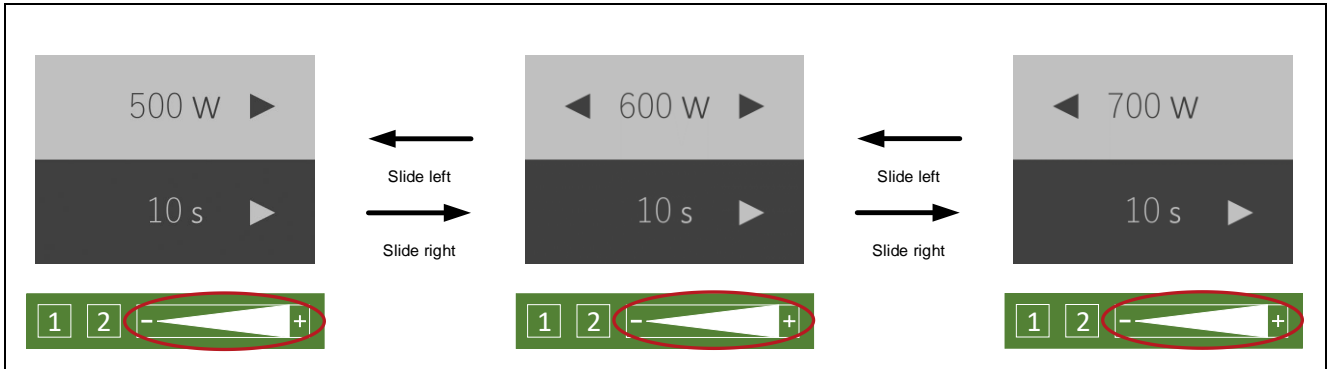

Figure 6-8 Setting the number of watts

6.3.4.2 Move the cursor

While the Cook detail setting screen is displayed, touching the "2" button can move the cursor. The item with a light-colored background is selected.

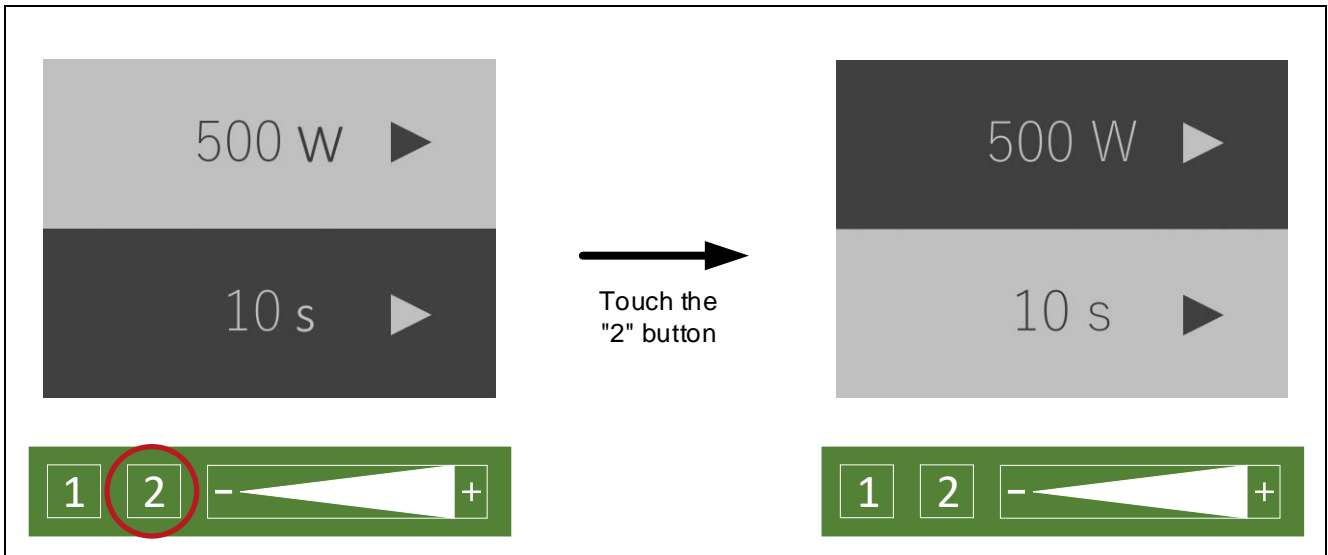

Figure 6-9 How to operate the cursor on the Cook detail setting screen

6.3.4.3 Set the number of seconds

While the cursor is on the lower side, the number of seconds can be set with the slider. "10s", "20s" and "30s" can be selected as the cooking time.

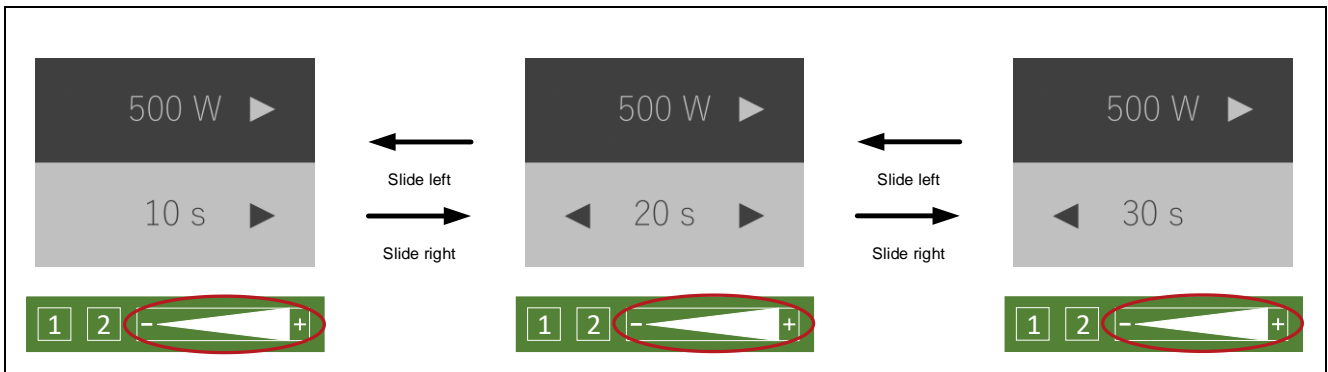

Figure 6-10 Setting the number of seconds

6.3.4.4 Start cooking

While the Cook detail setting screen is displayed and the cursor is on the lower side, touching the "2" button can start cooking.

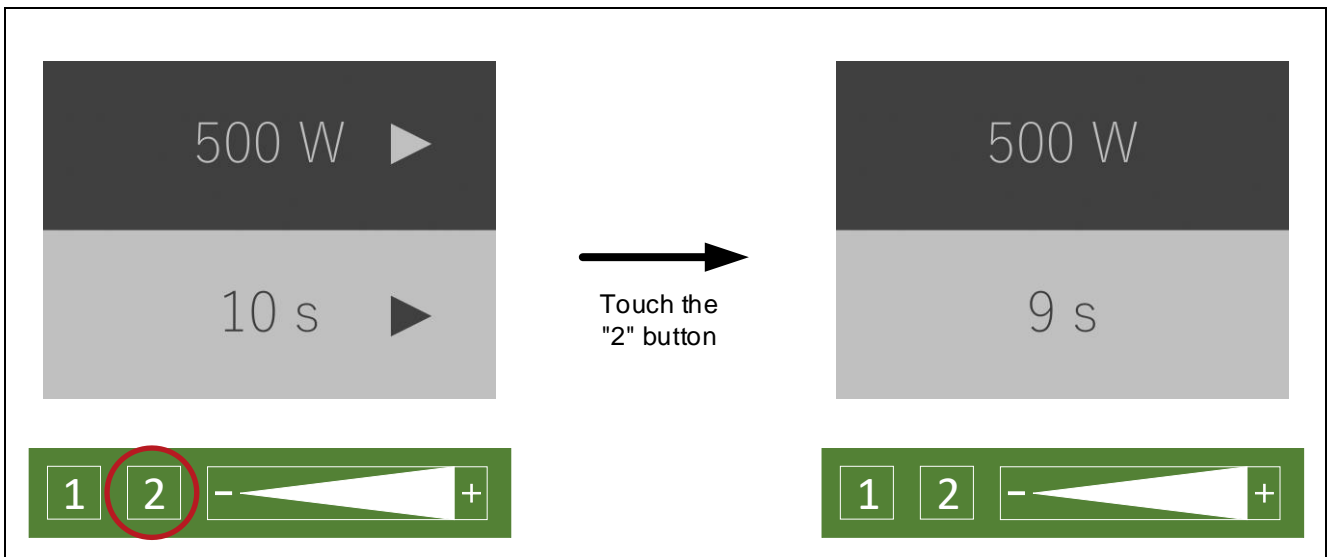

Figure 6-11 Start cooking in Manual mode

6.4 Defrost setting

6.4.1 Move to mode selection screen

While "Defrost" is selected on the menu screen, touching the "2" button can move to the Defrost mode selection screen.

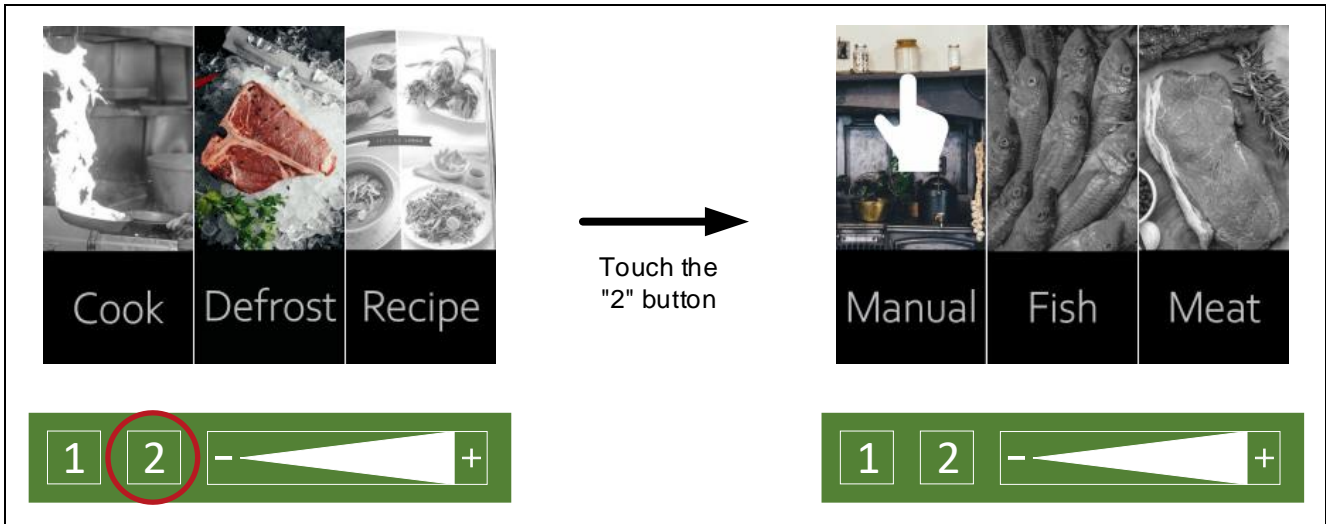

Figure 6-12 Move to the Defrost mode selection screen

6.4.2 Select mode

While the Defrost mode selection screen is displayed, "Manual", "Fish" or "Meat" can be selected with the slider operation.

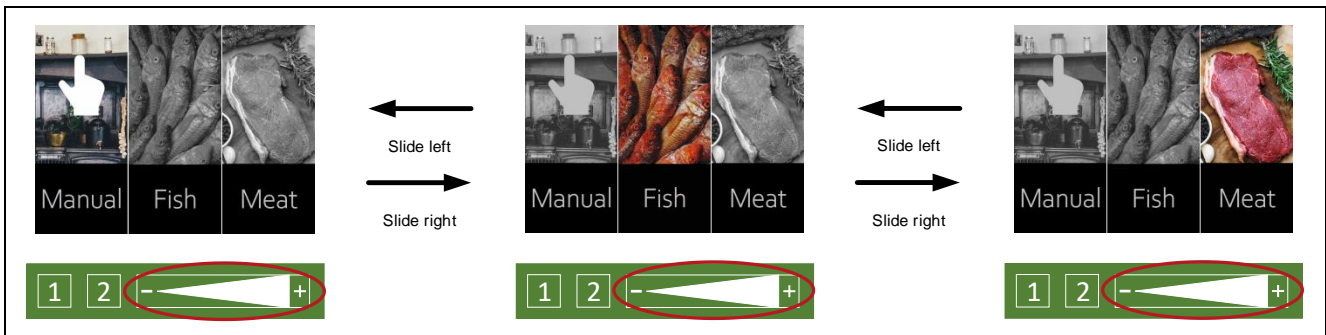

Figure 6-13 How to operate the Defrost mode selection screen

6.4.3 Select Manual

While "Manual" is selected on the Defrost mode selection screen, touching the "2" button can move to the Defrost detail setting screen.

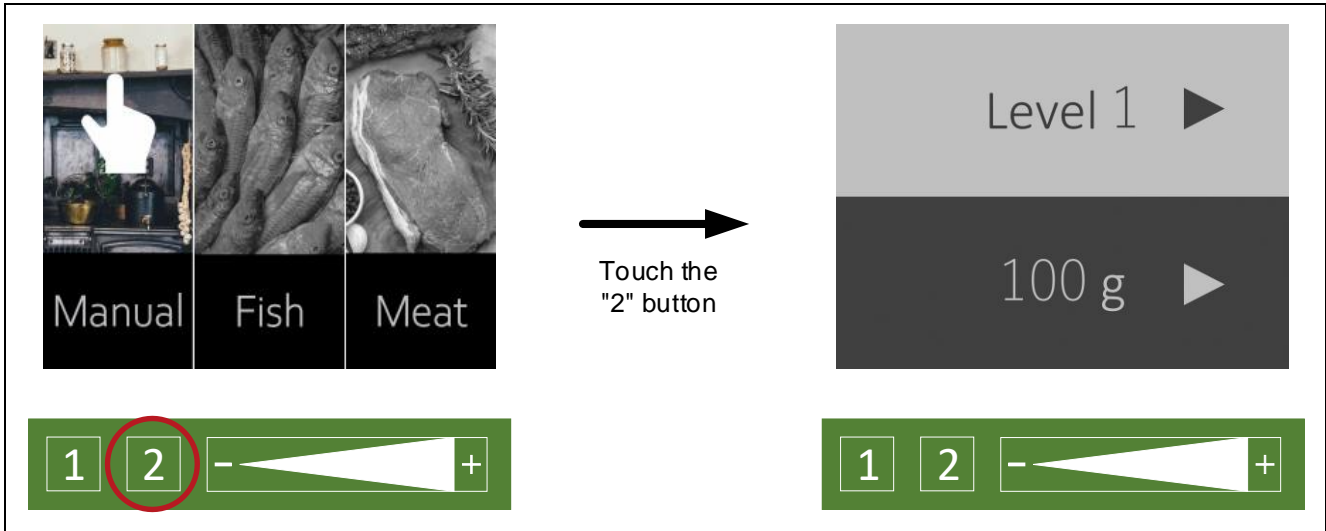

Figure 6-14 Move to the Defrost detail setting screen

6.4.3.1 Set the level of defrosting

While the cursor is on the upper side, the level of defrosting can be set with the slider. "Level1", "Level2" and "Level3" can be selected as the defrosting level.

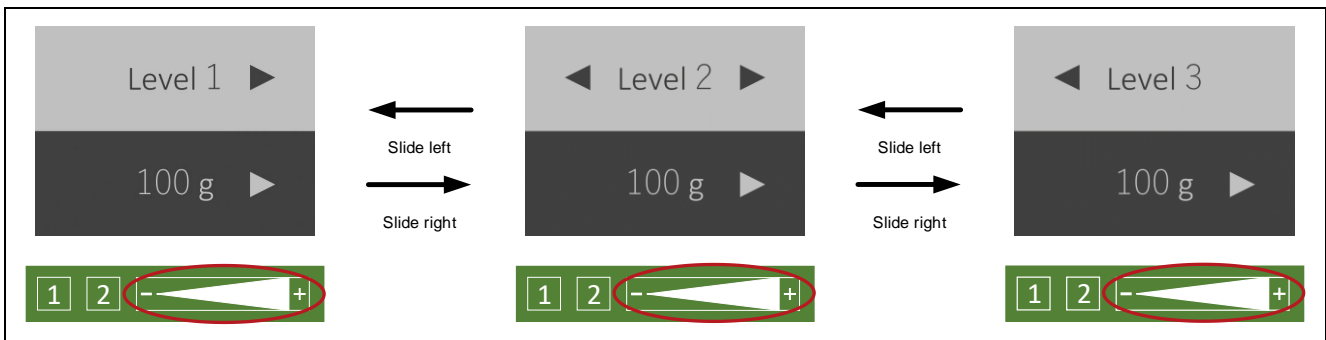

Figure 6-15 Setting the level of defrosting

6.4.3.2 Move the cursor

While the Defrost detail setting screen is displayed, touching the "2" button can move the cursor. The item with a light-colored background is selected.

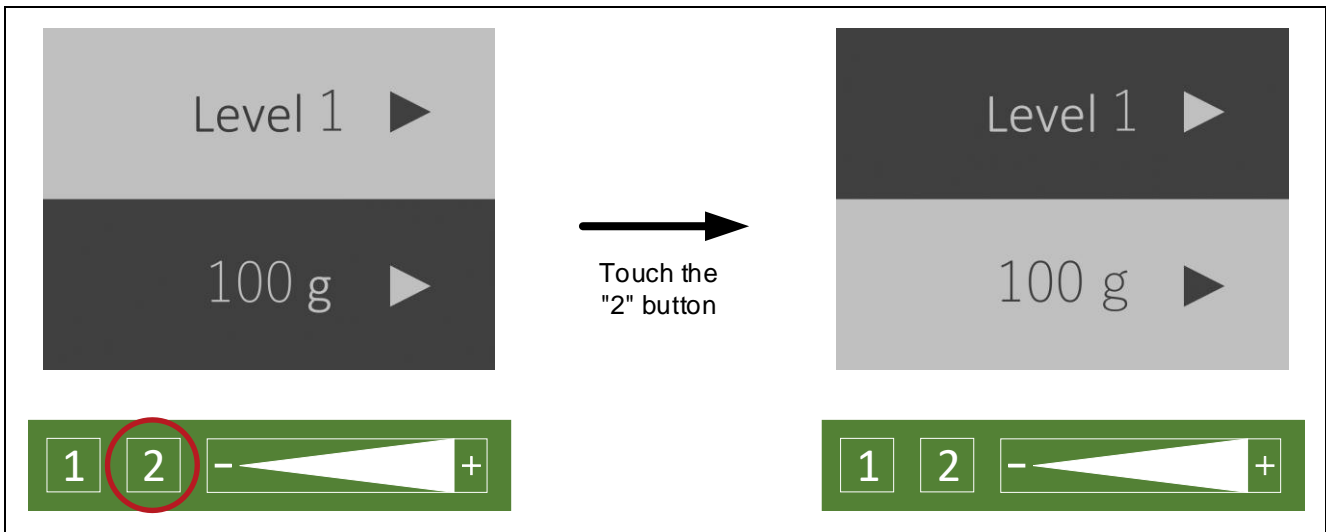

Figure 6-16 How to operate the cursor on the Defrost detail setting screen

6.4.3.3 Set the number of grams

While the cursor is on the lower side, the number of grams can be set with the slider. "100g", "200g" and "300g" can be selected as the defrosting amount.

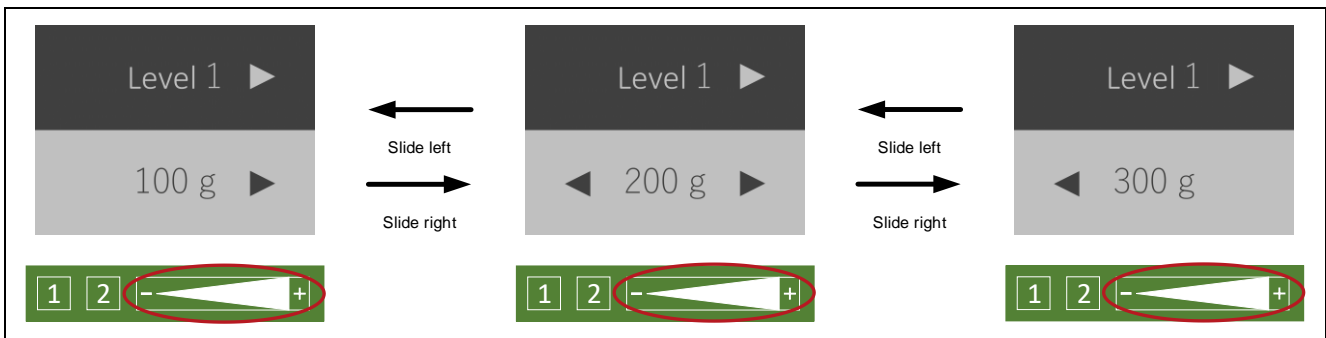

Figure 6-17 Setting the number of grams

6.4.3.4 Start defrosting

While the Defrost detail setting screen is displayed and the cursor is on the lower side, touching the "2" button can start defrosting.

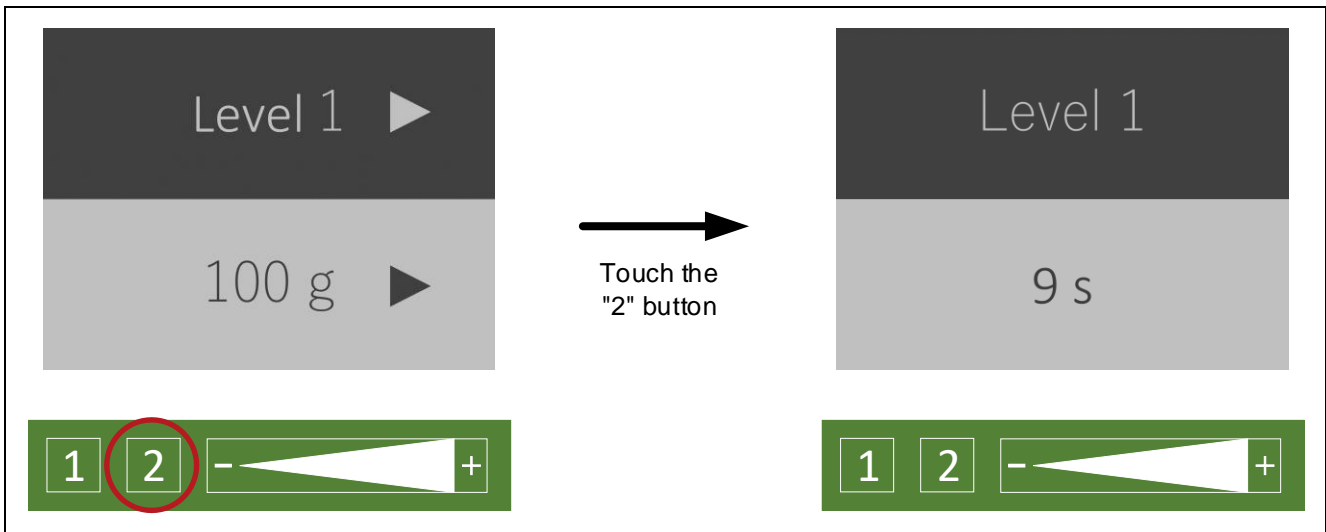

Figure 6-18 Start defrosting in Manual mode

6.4.4 Select Fish

While "Fish" is selected on the Defrost mode selection screen, touching the "2" button can start defrosting with the settings for "Fish".

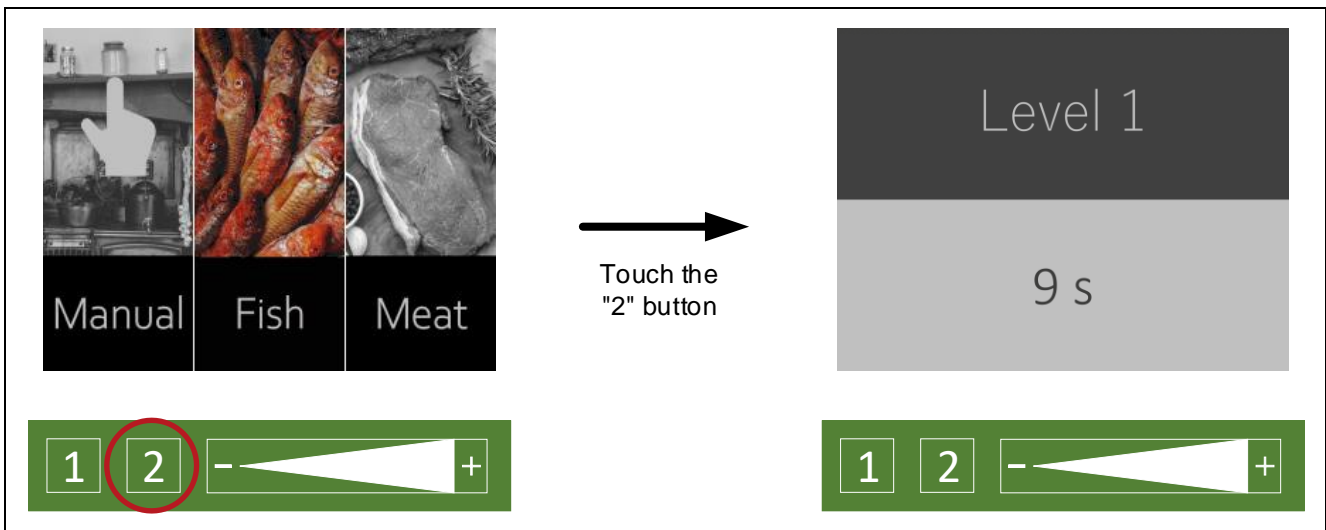

Figure 6-19 Start defrosting in Fish mode

6.4.5 Select Meat

While "Meat" is selected on the Defrost mode selection screen, touching the "2" button can start defrosting with the settings for "Meat".

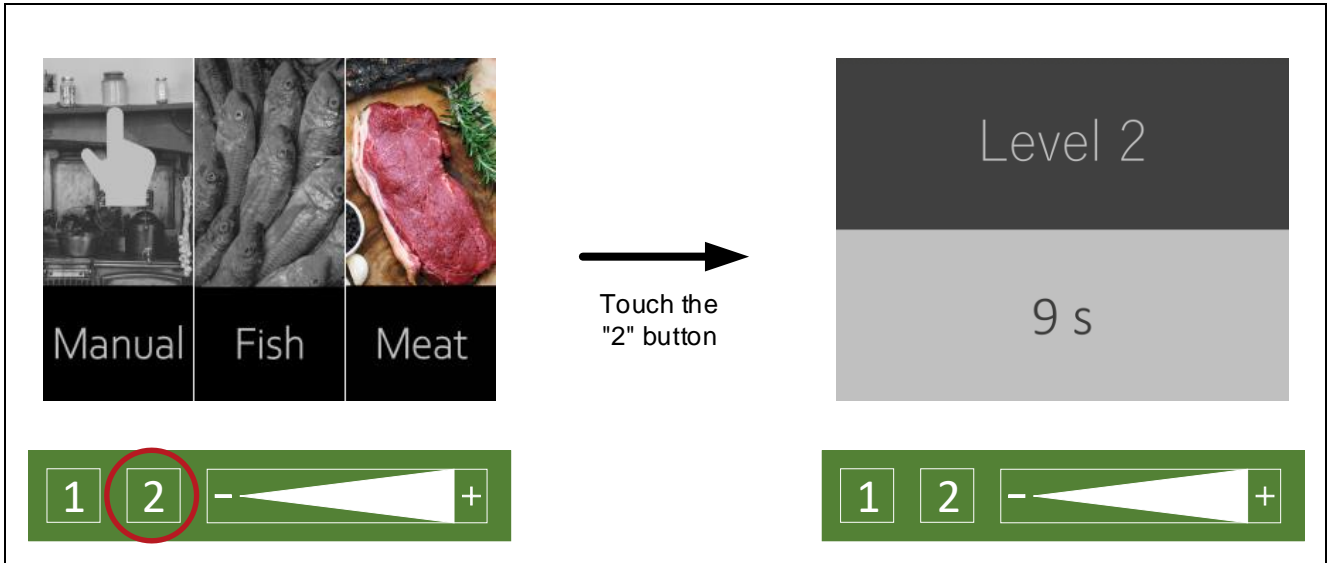

Figure 6-20 Start defrosting in Meat mode

6.5 Recipe setting

Recipe mode is not available with the firmware ver.0.90.

6.5.1 Move to recipe selection screen

While "Recipe" is selected on the menu screen, touching the "2" button can move to the Recipe selection screen.

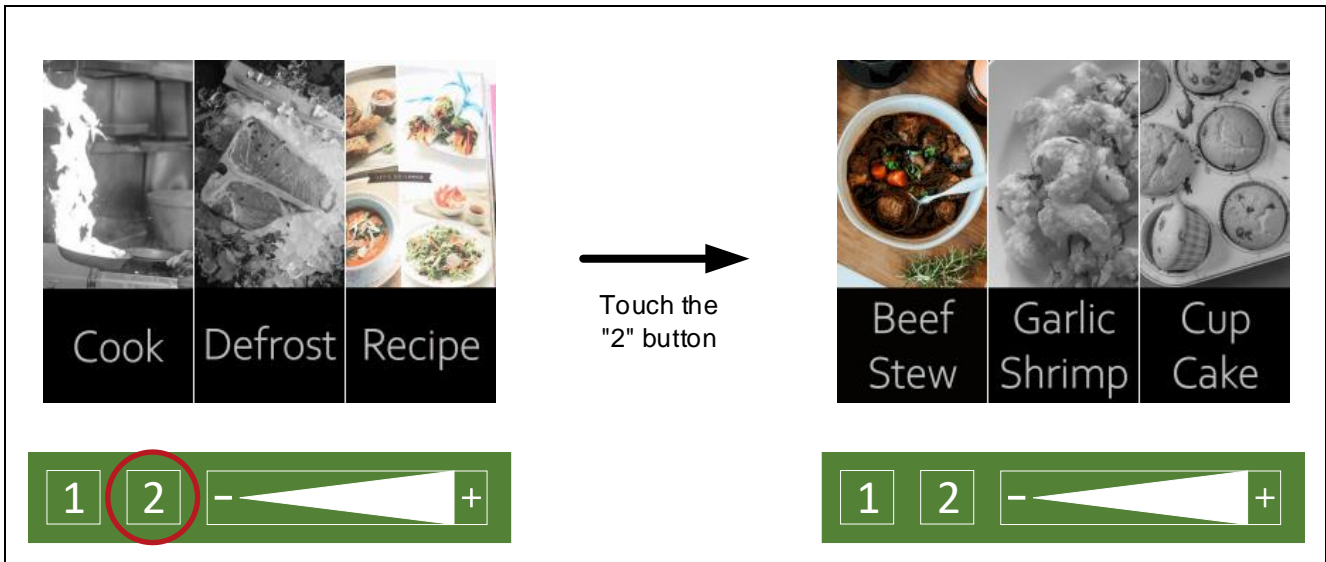

Figure 6-21 Move to the Recipe selection screen

6.5.2 Select recipe

While the Recipe selection screen is displayed, "Beef Stew", "Garlic Shrimp" or "Cup Cake" can be selected with the slider operation.

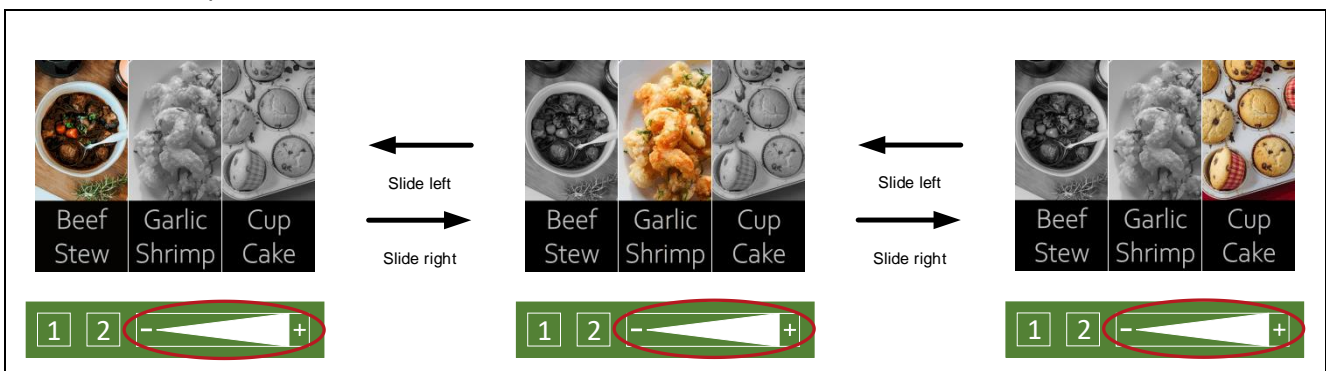

Figure 6-22 How to operate the Recipe selection screen

6.5.3 Select Beef Stew

While "Beef Stew" is selected on the Recipe selection screen, touching the "2" button can start cooking for the Settings for Beef Stew.

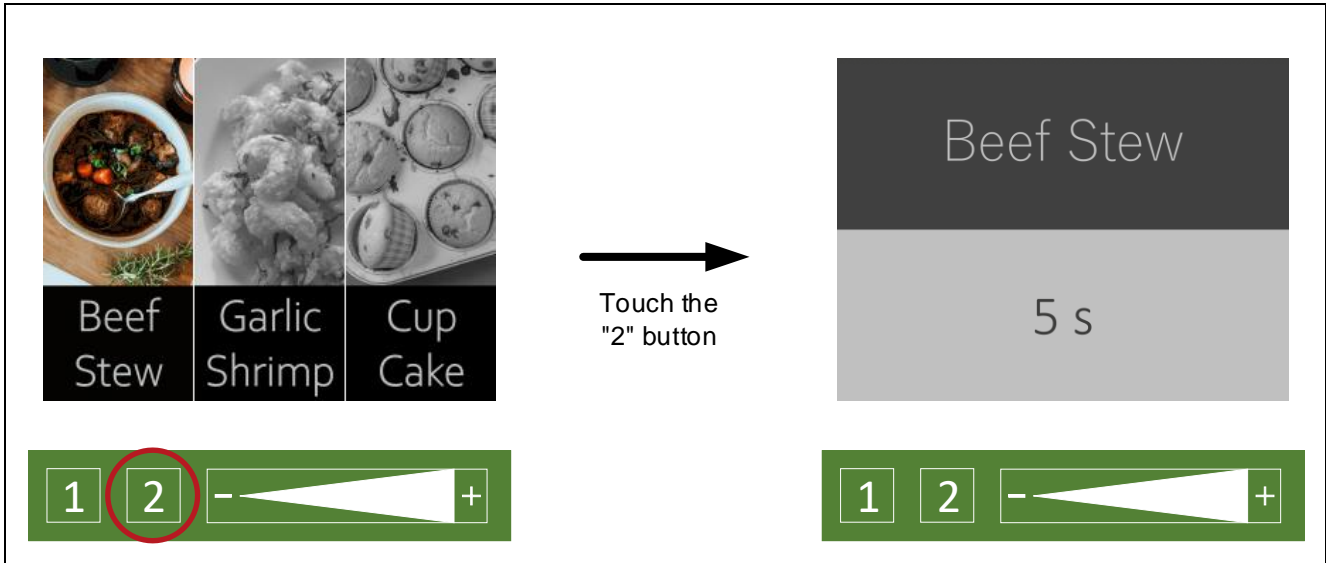

Figure 6-23 Start cooking in Beef Stew mode

6.5.4 Select Garlic Shrimp

While "Garlic Shrimp" is selected on the Recipe selection screen, touching the "2" button can start cooking for the Settings for Garlic Shrimp.

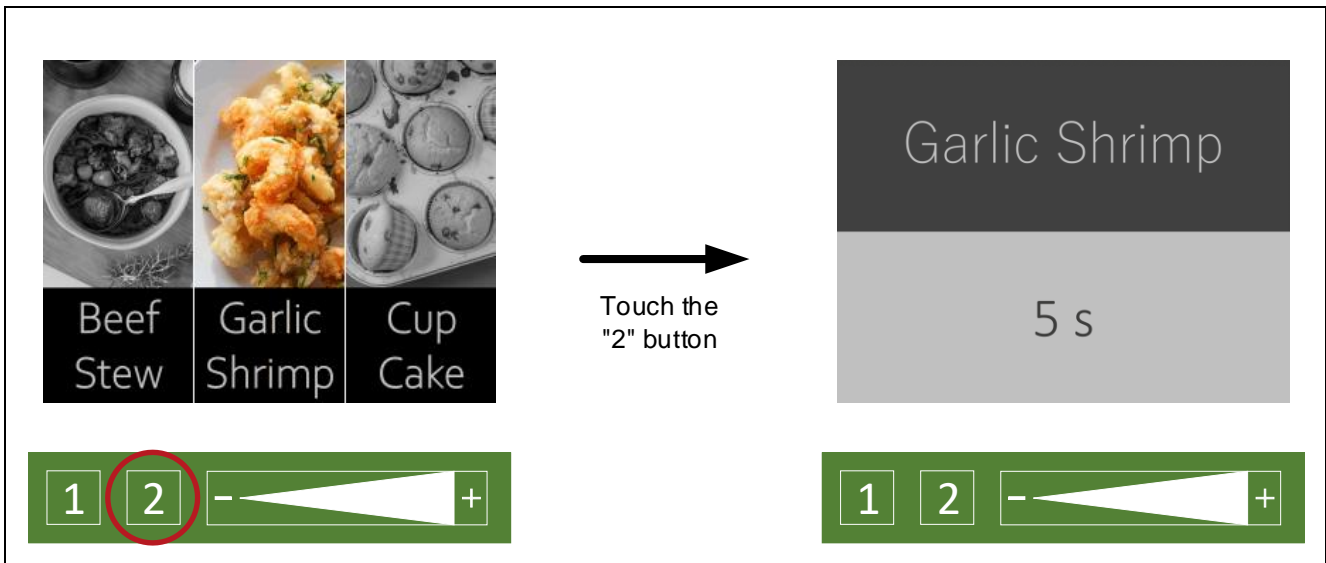

Figure 6-24 Start cooking in Garlic Shrimp mode

6.5.5 Select Cup Cake

While "Cup Cake" is selected on the Recipe selection screen, touching the "2" button can start cooking for the Settings for Cup Cake.

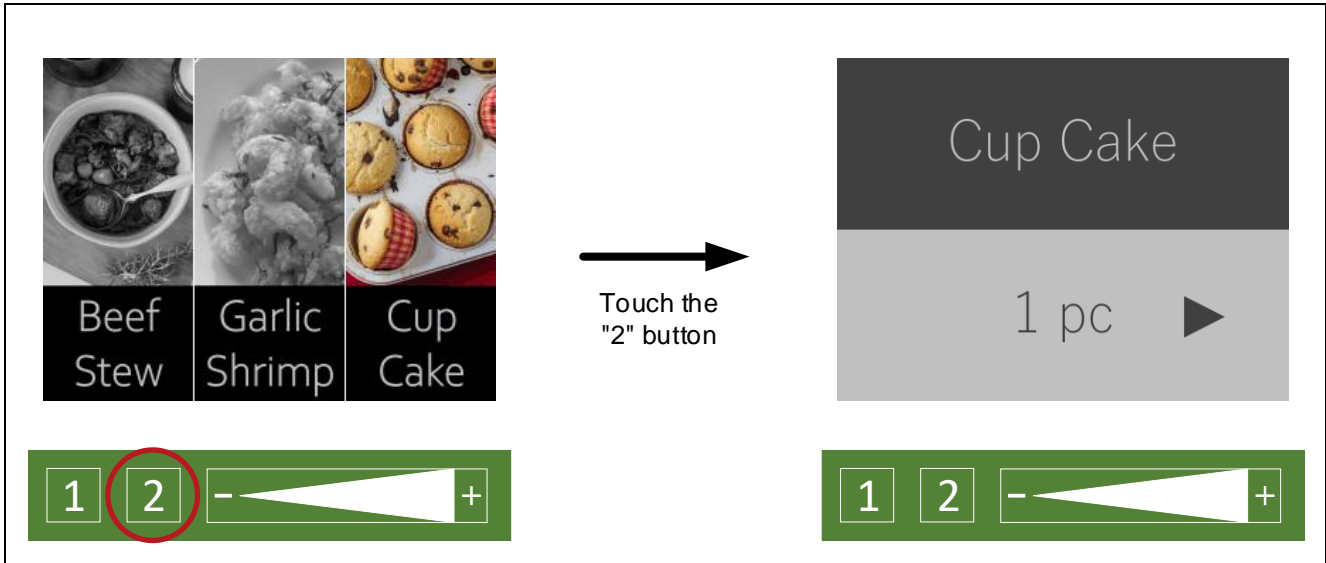

Figure 6-25 Move to the Cup Cake detail setting screen

6.5.5.1 Set the number of cupcakes

You can set the number of cupcakes with the slider. "1pc", "2pcs" and "3pcs" can be selected as the cooking amount.



Figure 6-26 Setting the number of cupcakes

6.5.5.2 Start cooking

While the Cup Cake detail setting screen is displayed, touching the "2" button can start cooking.

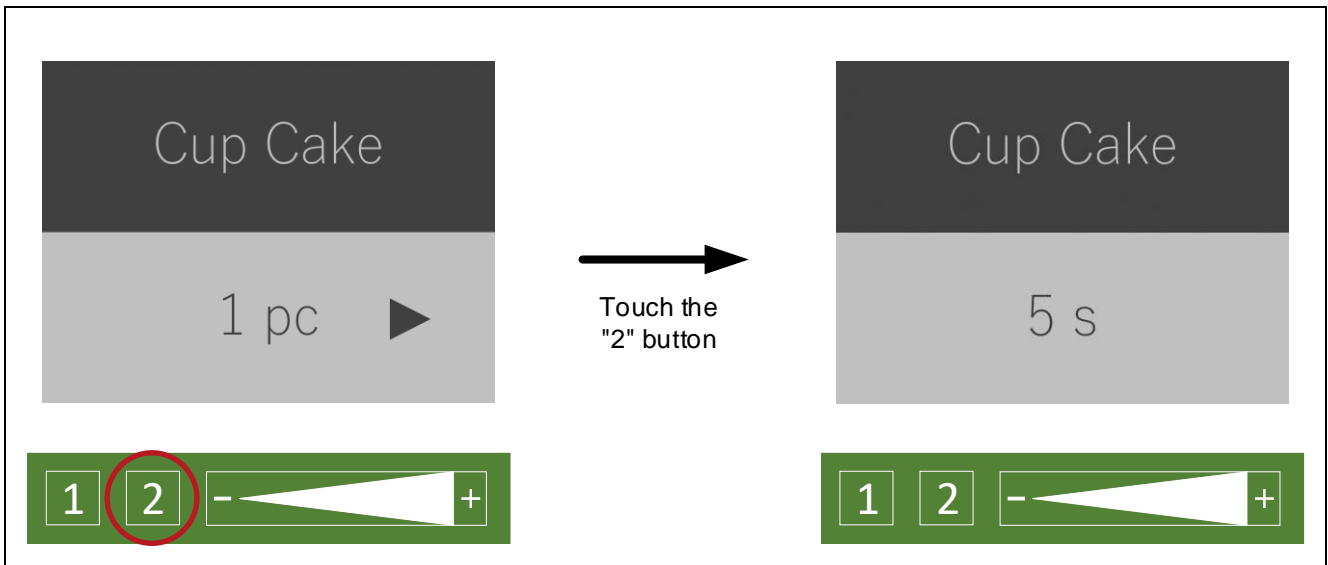

Figure 6-27 Start cooking in Cup Cake mode

6.6 About the "1" button

The "1" button returns to the menu screen from any screen.

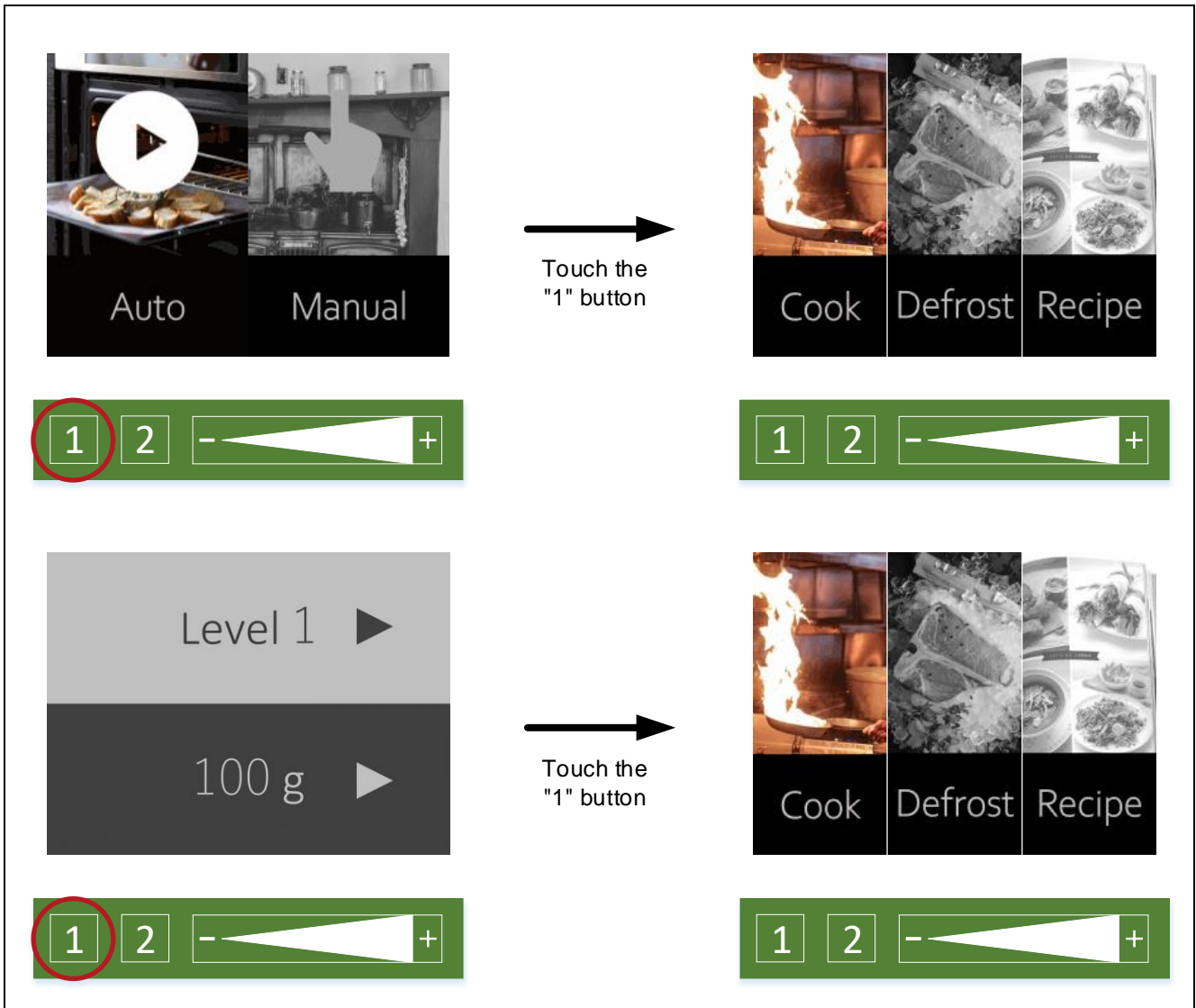

Figure 6-28 Example of "1" button operation

6.7 About the cooking completion screen

While completed cooking, the cooking completion screen is displayed for 3 seconds. After that, move to the menu screen automatically.

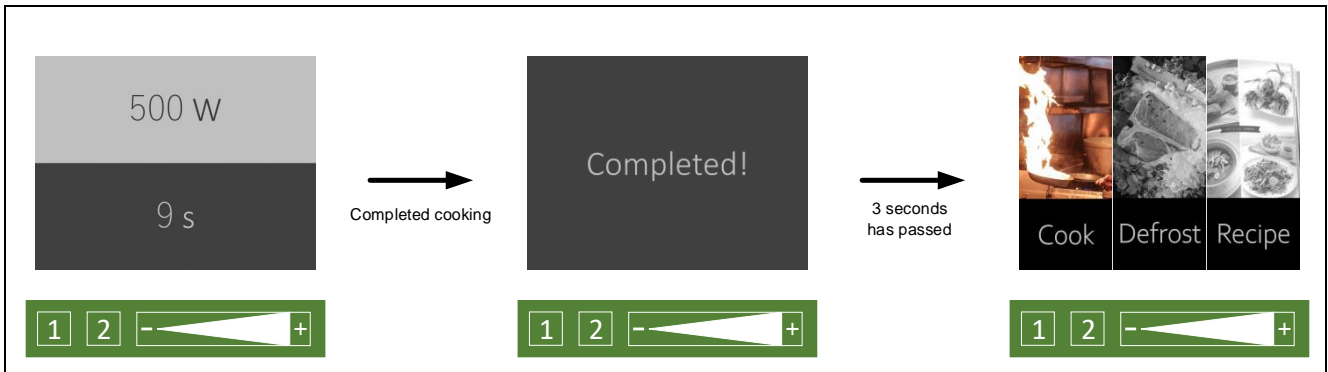

Figure 6-29 Example of cooking completion operation

6.8 Automatic LCD off function

If no touch operation is performed for 10 seconds, the LCD will turn off. Touching any buttons will return to the previous screen.

7. Update firmware version

Two version of firmware are available in this application note. One of them has firmware version 0.90 and its file name is userprog_v0.90.rsu, the other firmware version is 1.00 and its file name is userprog_v1.00.rsu. In the initial state, version 0.90 firmware including a bootloader that supports FOTA is written, and can update it to version 1.00 firmware by following the procedure described later.

The differences by firmware version are shown below. The firmware version in use is displayed on the initial screen. In addition, the menu screen is different for each version.



Figure 7-1 Differences by firmware version

1. Upload and save the OTA update firmware userprog_v0.90.rsu or userprog_v1.00.rsu to Amazon S3 bucket as described in "1.2 Create an Amazon S3 bucket" in "How to implement FreeRTOS OTA by using Amazon Web Services on RX65N".

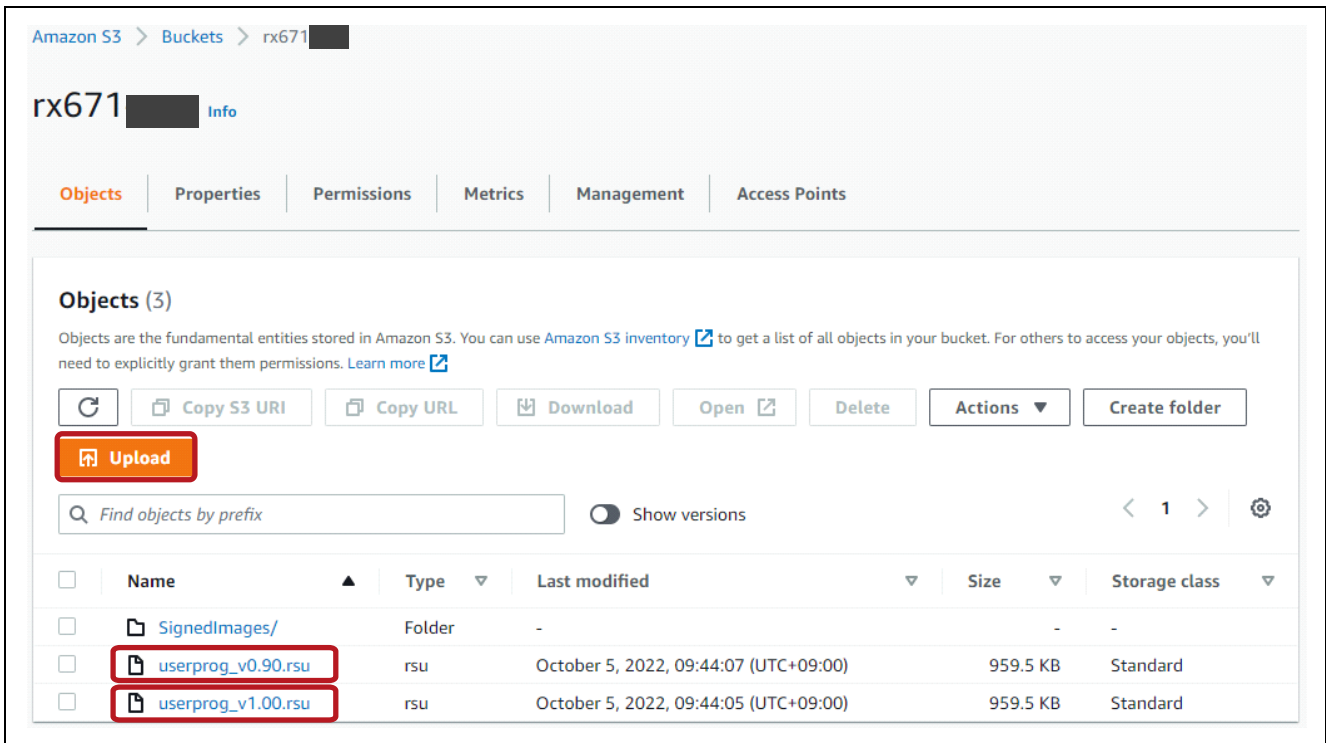

Figure 7-2 userprog.rsu upload

2. Create job to update firmware on RX671.

AWS IoT Jobs is a service that notifies one or more connected devices that they have a pending "job". A job can be used to manage large numbers of devices, update firmware and security certificates on devices, or perform administrative tasks such as rebooting and diagnostics devices.

- Select [AWS IoT] → [Manage] → [Jobs] → [Create] → [Create OTA Update job] → Set job name → [Next]
- Create a FreeRTOS OTA update job as below:
 - Select the name of the thing. (Figure 7-3 (a), Figure 8-11)
 - Select Code signing profile. (Figure 7-3 (b))
 - Select firmware image from S3 for FOTA. (Figure 7-3 (c))
 - Select IAM role. (Figure 7-3 (d))
- Click [Next]

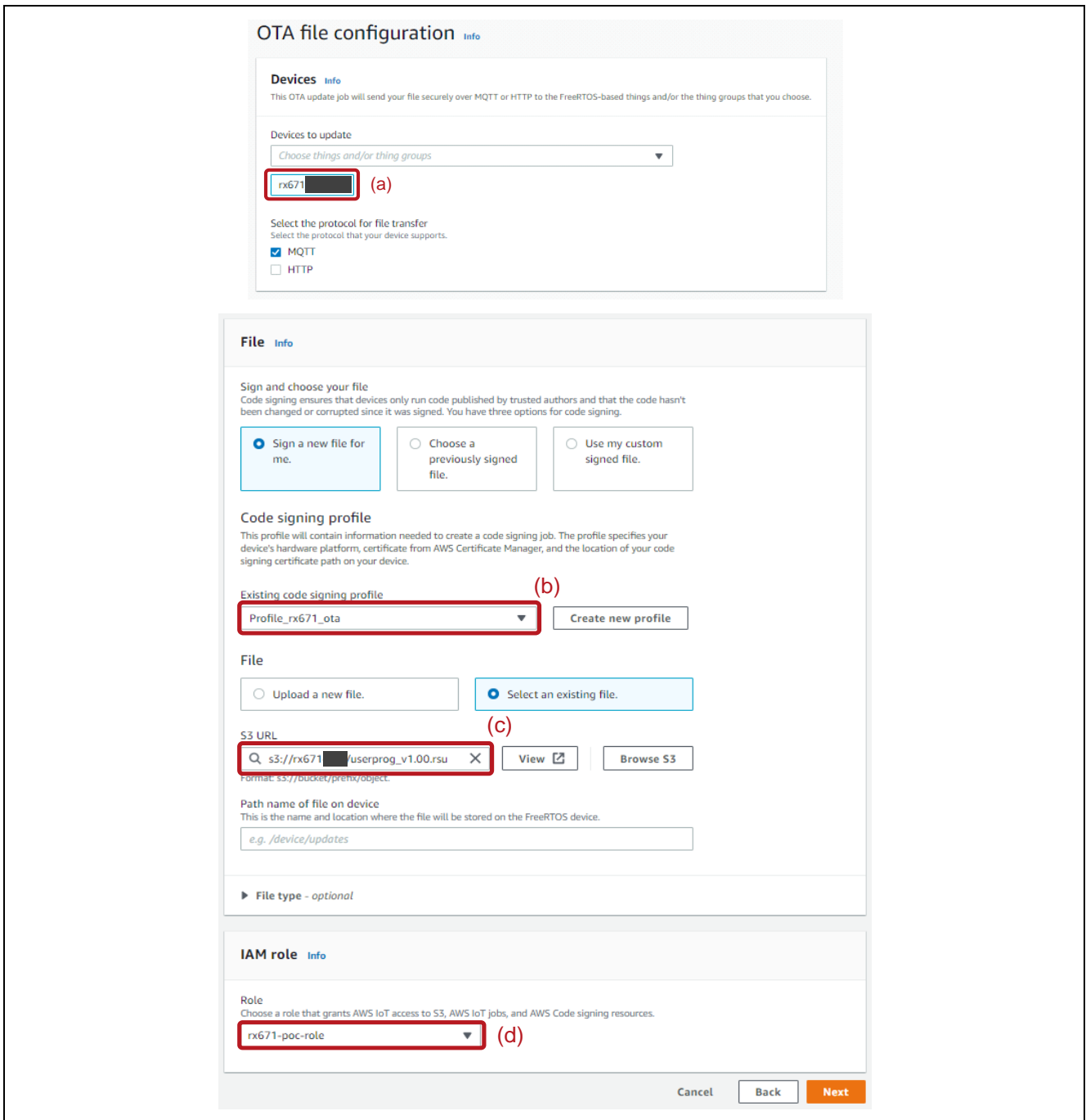

Figure 7-3 Job creation (1)

3. Click [Create job].

OTA job configuration [Info](#)

Job run type

Choose how to run this job.

- Your job will complete after deploying to the devices and groups that you chose (snapshot)
- Your job will continue to deploy to any devices added to the groups that you chose (continuous)

▶ **Job start rollout configuration - optional**

Specify how quickly devices will be notified when a pending job starts.

▶ **Job stop configuration - optional**

These configurations define when to automatically stop the job. The job stops if a percentage of devices fail the deployment after a minimum number have deployed. The job cancels if any of the criteria are met after the job starts.

▶ **Job run timeout configuration - optional**

Specify how long the job will run.

Cancel

Figure 7-4 Job creation (2)

- Open Tera Term and confirm that the firmware has been updated.
OTA demonstration version is 1.00 and has been updated successfully.

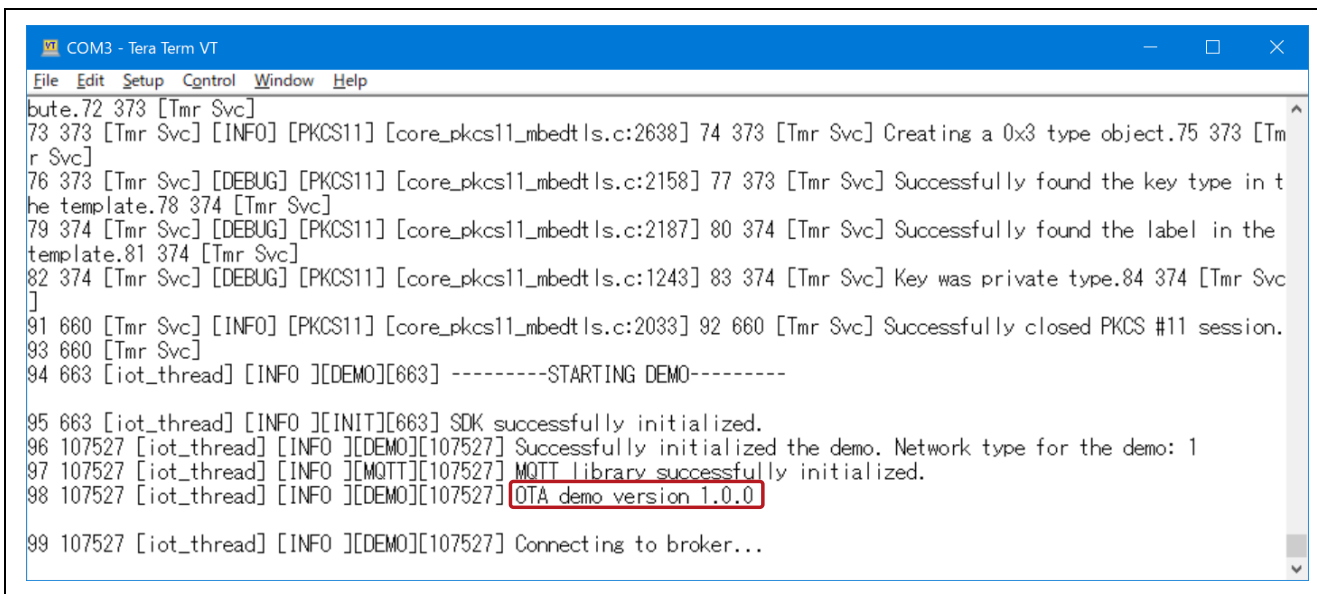

Figure 7-5 Check Execution Result

The Tera Term setup is shown below. If do not have Tera Term on PC, please download from <https://tssh2.osdn.jp/index.html.en>.

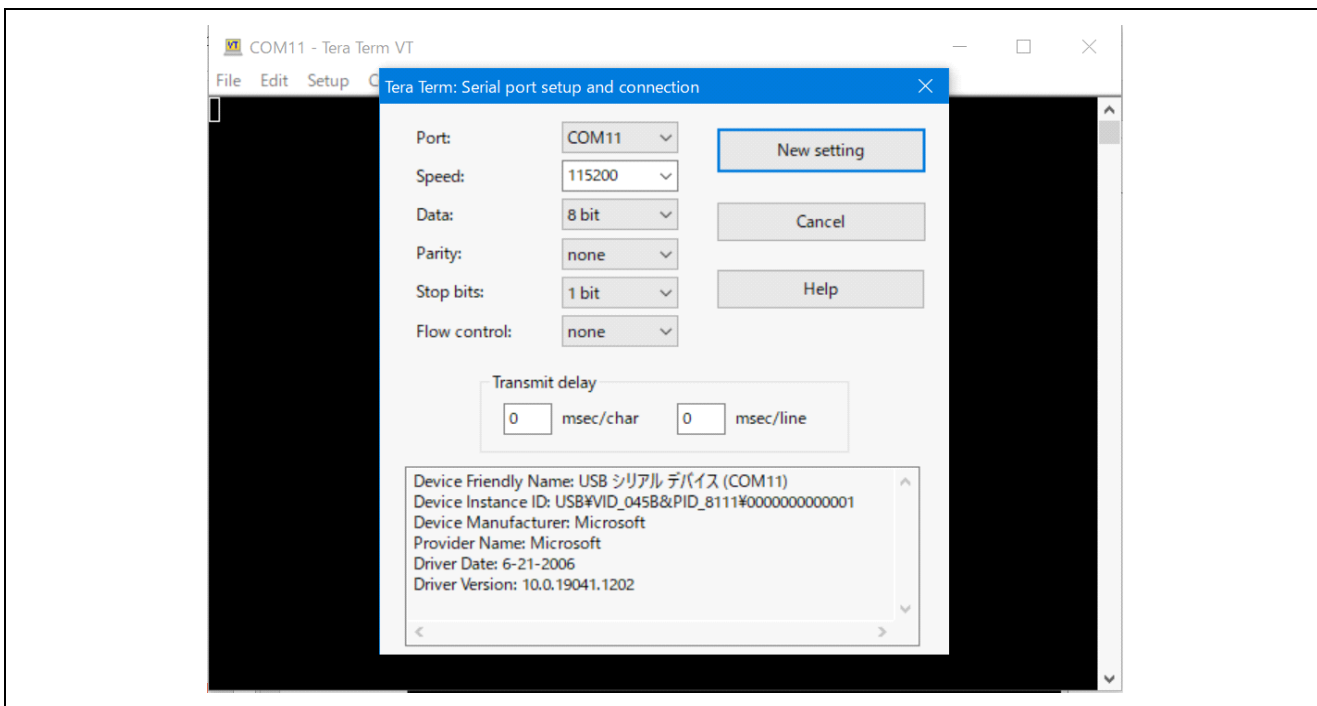

Figure 7-6 Tera Term

5. Check job status to be "Succeeded".

The screenshot shows the AWS IoT console interface for managing remote actions. The breadcrumb trail is: AWS IoT > Manage > Remote Actions > Jobs > AFR_OTA-job_ota_rx671. The page title is 'AFR_OTA-job_ota_rx671 info'. There are buttons for 'Cancel', 'Edit', and 'Save as a job template'. The 'Job executions' tab is selected, showing an 'Execution overview' table with counts for Succeeded (1), Failed (0), Canceled (0), Rejected (0), Queued (0), In progress (0), Removed (0), and Timed out (0). Below this is a 'Job executions (1) info' section with a search bar and a dropdown menu. A table lists the job execution details:

Thing name	Retry attempts	Retries remain...	Last updat...	Queued at	Status
rx671	-	Retries not set	September 0...	September 0...	Succeeded

Figure 7-7 Check Succeeded

8. How to create a user program that supports OTA

This section describes how to rewrite the program from the cloud by OTA.

The program is rewritten in the background and automatically switched to the new program at the next power-on.

First, user can select the version of Amazon FreeRTOS package. The selected version will be downloaded from GitHub and imported automatically into the project. This makes it easier for the user, so that the user can focus only on Amazon FreeRTOS configuration and writing program.

8.1 AWS Preparation

To perform OTA from the cloud, it is necessary to prepare a cloud environment.

Use AWS as the cloud. Refer to the following for more information on preparing for AWS.

RX Family How to implement FreeRTOS OTA by using Amazon Web Services on RX65N (R01AN5549).

8.2 Import, configure head file and build aws_demos and boot_loader

The figure below shows how to import Amazon FreeRTOS project:

1. Launch e² studio.
2. Select [File] → [Import...]
3. Select [Renesas GitHub FreeRTOS (with IoT libraries) Project]

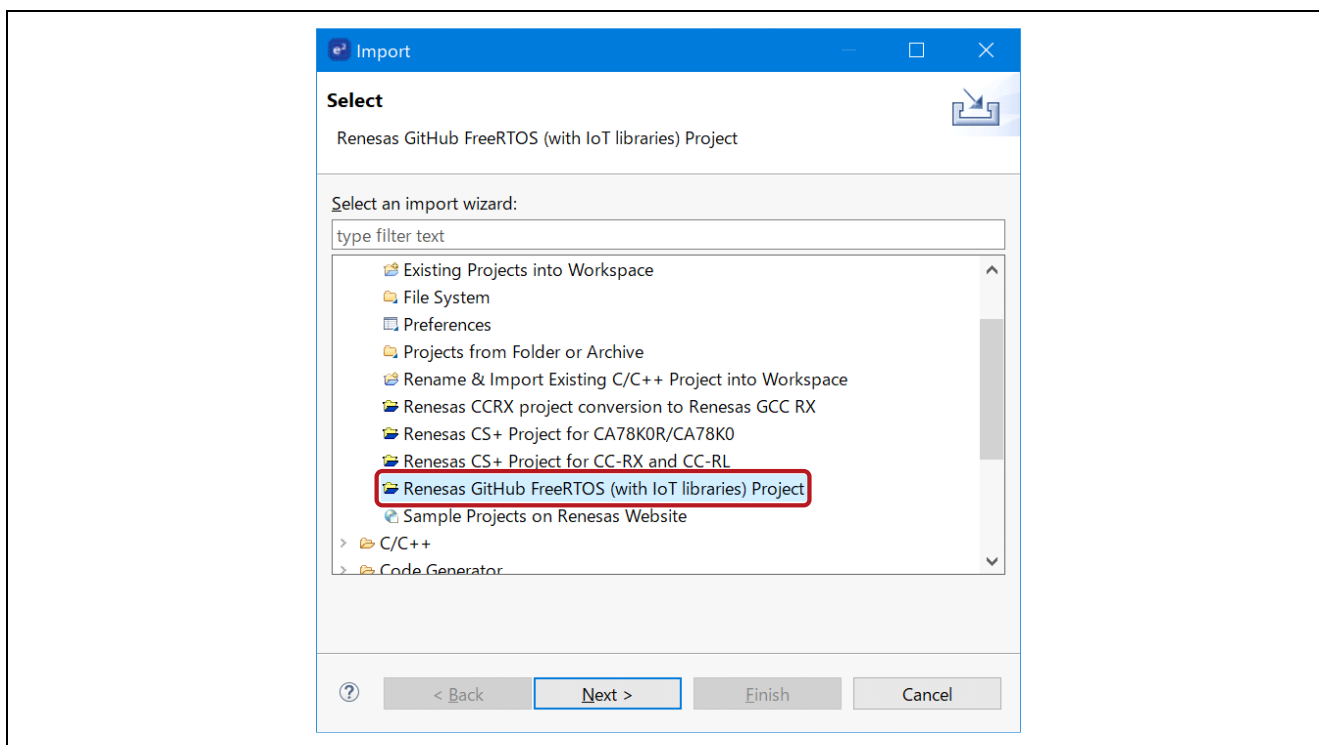

Figure 8-1 Importing Projects

4. Click [Check for more version...] to show the “FreeRTOS (with IoT libraries)” dialog.

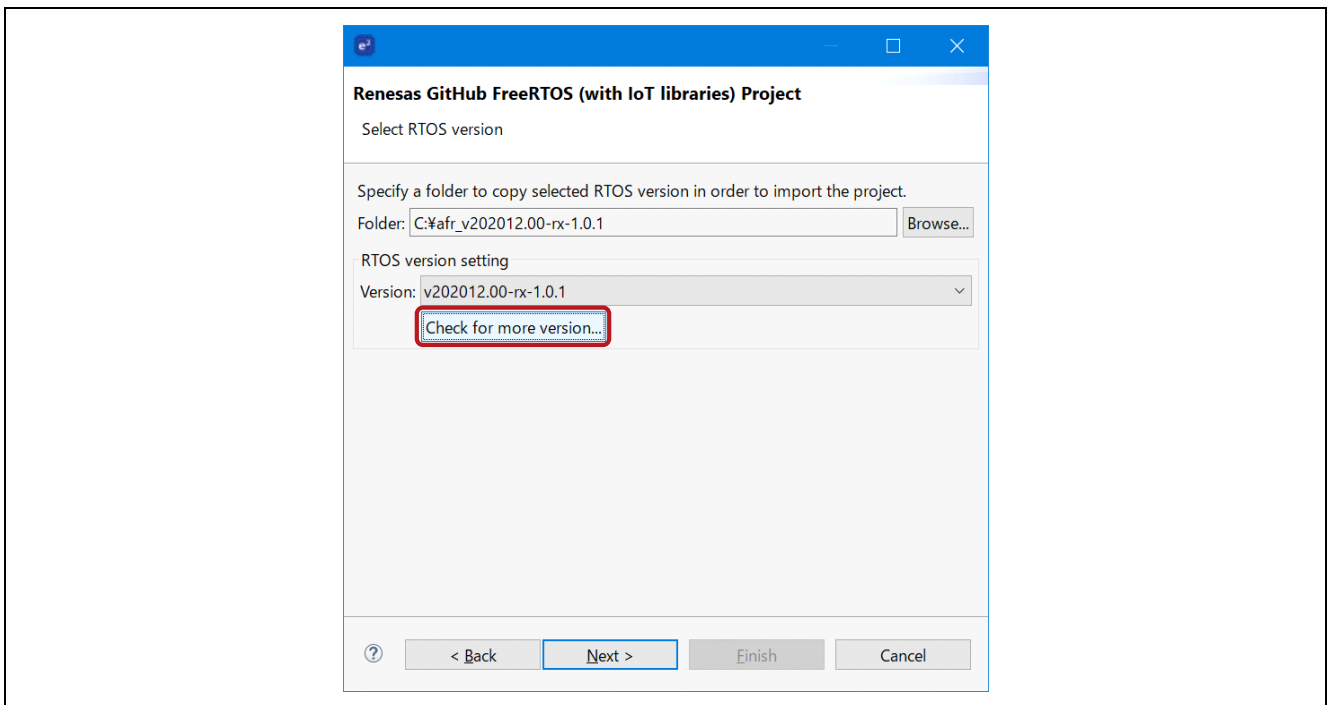

Figure 8-2 “FreeRTOS (with IoT libraries)” dialog

5. Select the latest version. (If the latest version is not displayed, create a new e² studio workspace)

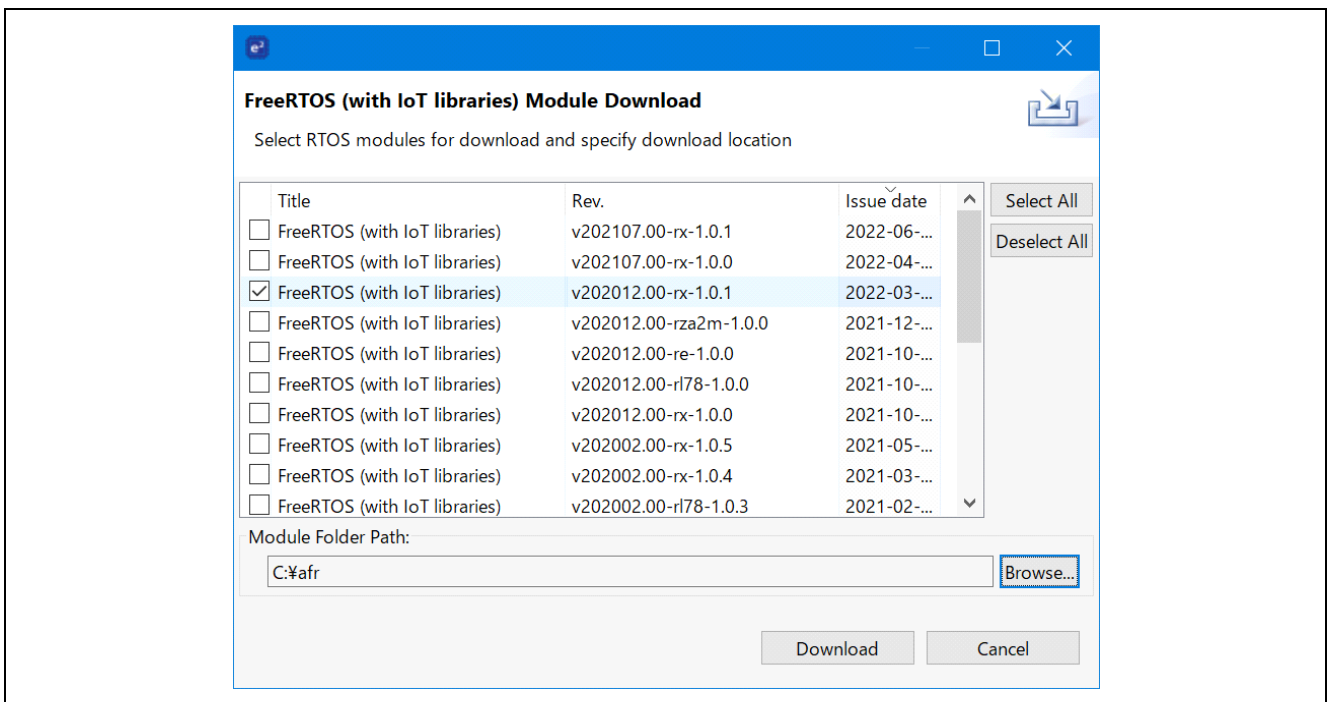

Figure 8-3 Select OS version

6. Agree to the end user license agreement

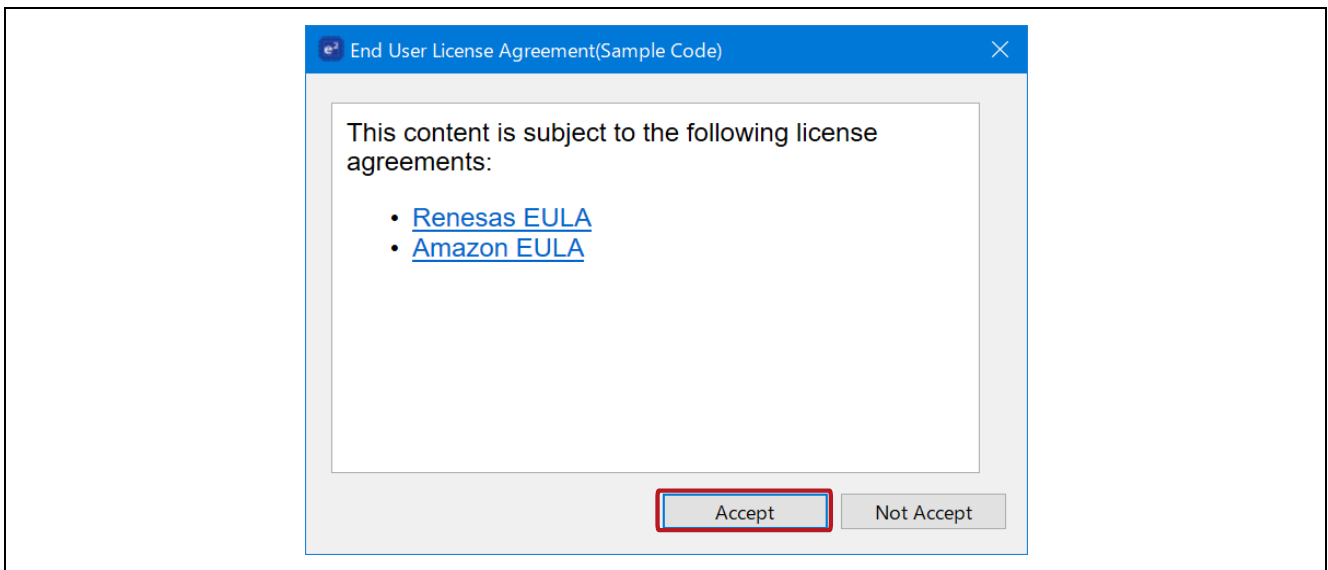

Figure 8-4 Agree to End User License Agreement

7. Wait for the download to complete.

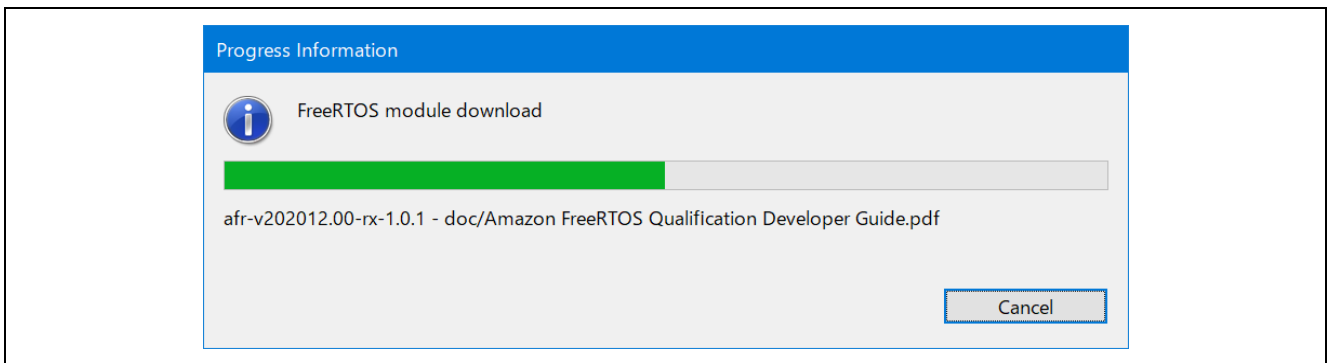

Figure 8-5 Waiting for download

8. Select the project to import. Select [aws_demos] and [boot_loader] project.

The `aws_demos` and `boot_loader` used in this demonstration have not been officially released in May 2023. Please contact our distributors and sales offices to request individual supplies.

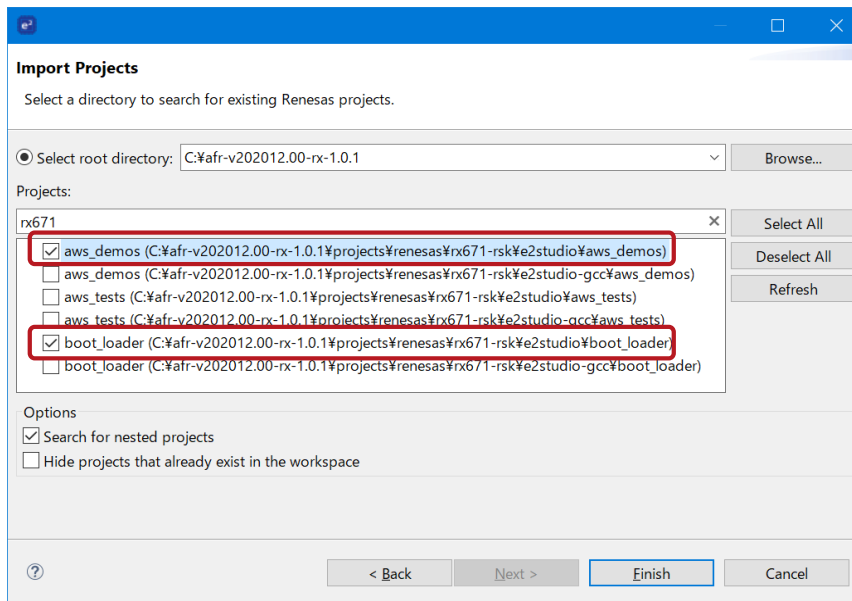

Figure 8-6 Select a project to import

- Open [Project] → [Properties] → [C/C++ Build] → [Tool Chain Editor] in both projects and select "Toolchain" and "Builder" to set the toolchain. Also, select [Setting] → [Toolchain] to set the version.

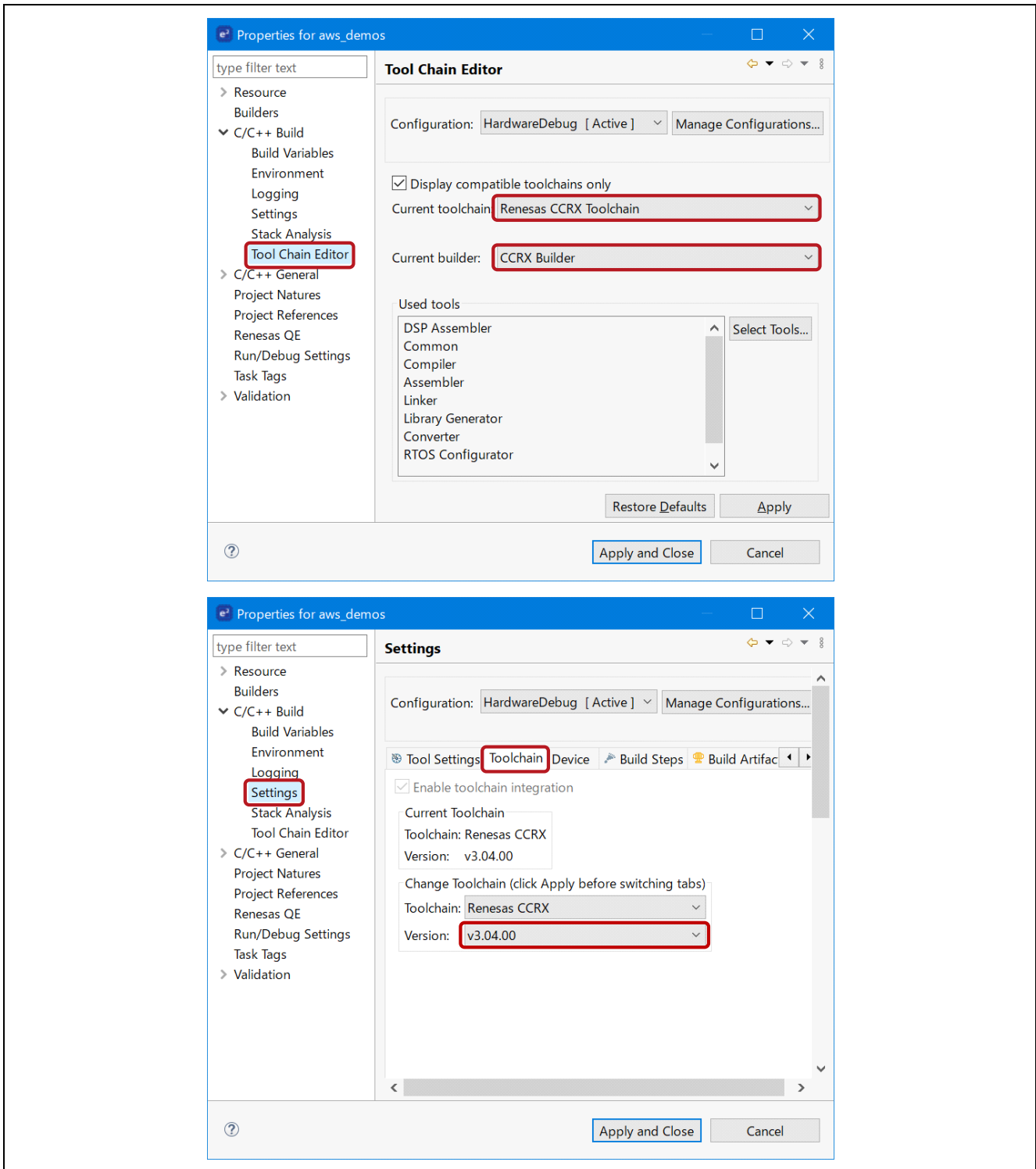

Figure 8-7 Tool Chain and Versioning

10. Select [Project] → [Properties] → [C/C++ Build] → [Settings] → [Converter] → [Output] and set [Motorola S format file].

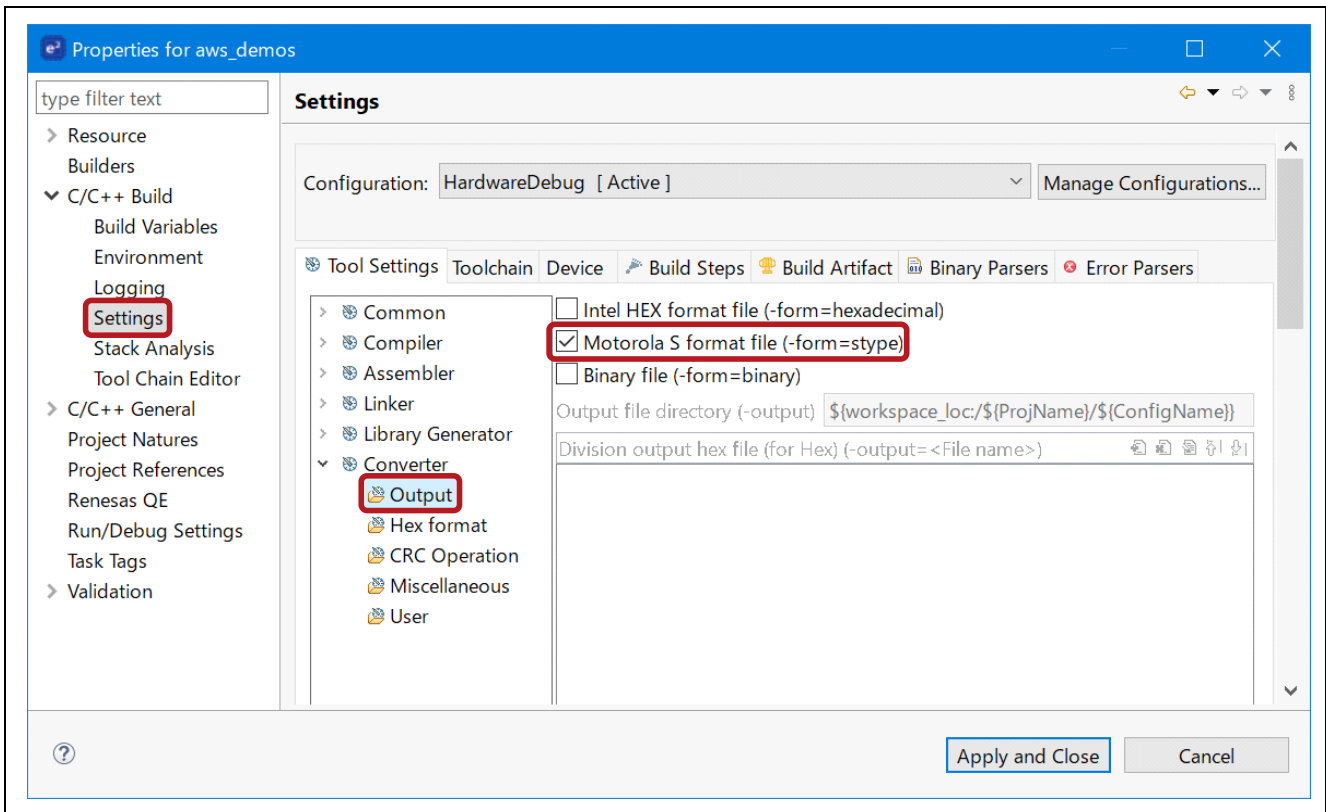

Figure 8-8 Motorola S format File output settings

11. Input the public key

In bootloader project, open

projects\renesas\rx671-rsk\le2studio\boot_loader\src\key\code_signer_public_key.h and input public key. Please refer to “Renesas MCU Firmware Update Design Policy” section “7.3 Generating ECDSA-SHA256 Key Pairs with OpenSSL” to create public key.

When completed to create public key, build and generate the boot_loader.mot file for the boot loader project.

The aws_demos and boot_loader used in this demonstration have not been officially released in May 2023. Please contact our distributors and sales offices to request individual supplies.

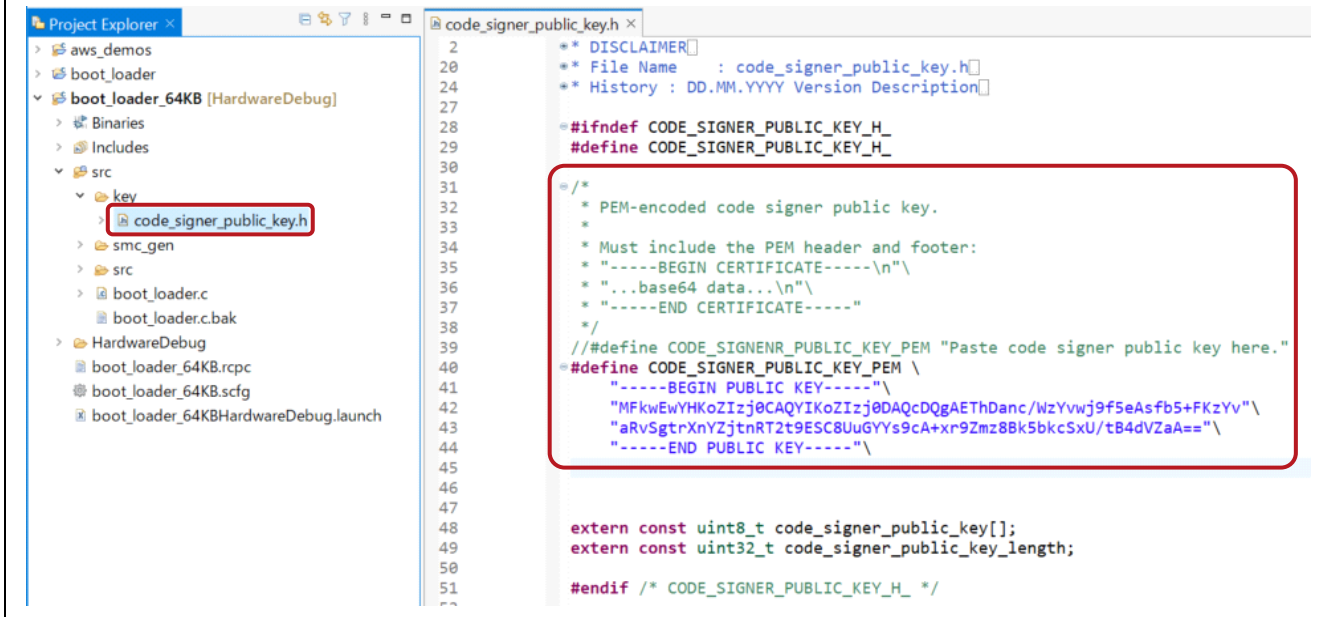

Figure 8-9 Input the public key

- 12. Open AWS IoT console
 - Browse to the AWS IoT console.
 - Select [Settings]. Make a note of the Endpoint. (Figure 8-10(e))

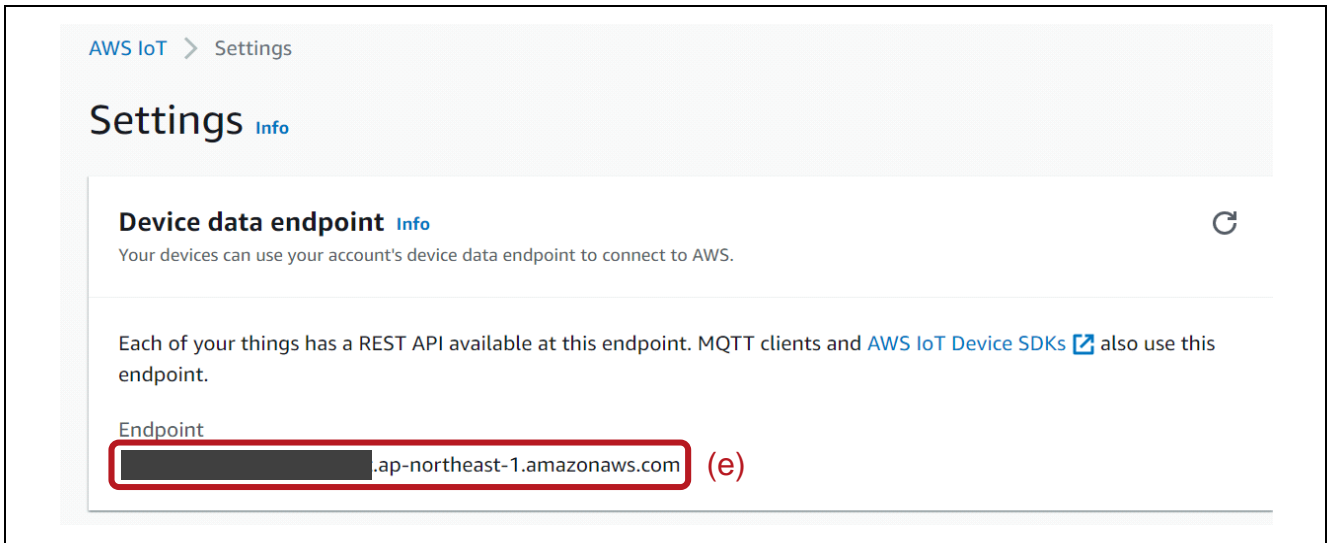

Figure 8-10 Check AWS Endpoint

- Select [Manage] → [Things]. Make a note of AWS IoT thing name. (Figure 8-11(f))

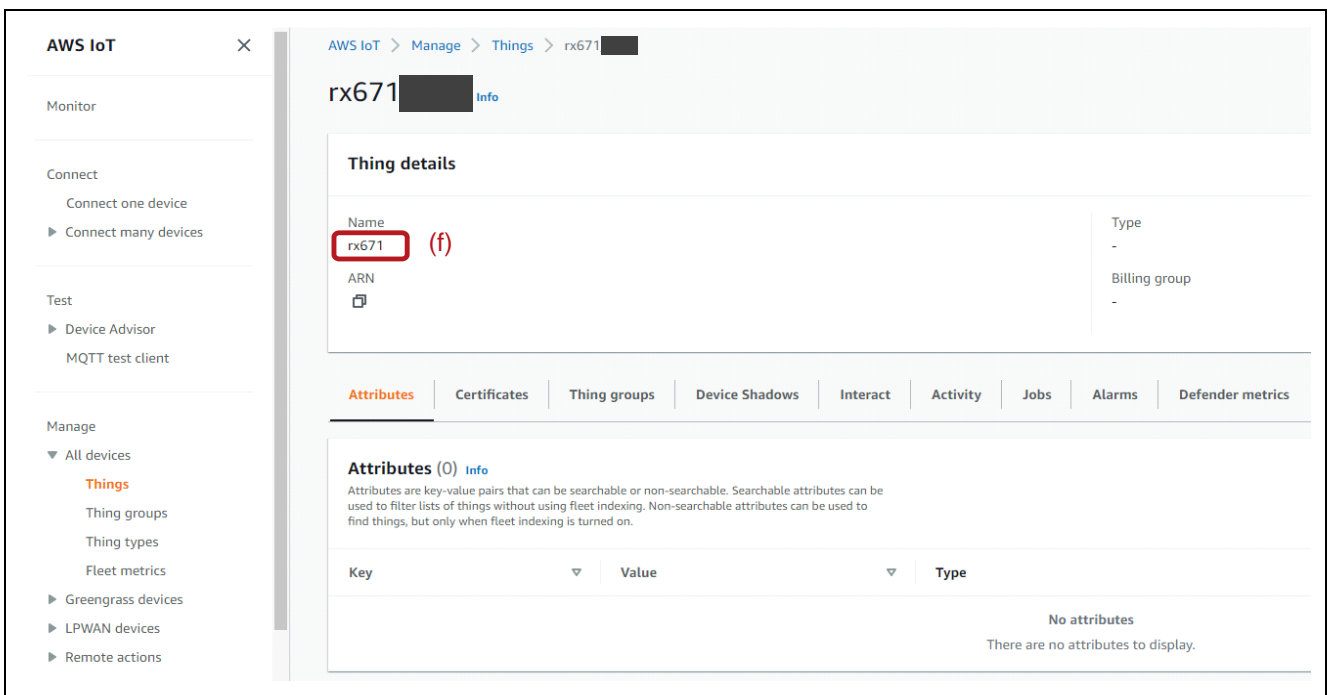

Figure 8-11 thing name

13. Open aws_demos project.

- Open /demos/include/aws_clientcredential.h and specify the following values
- #define clientcredentialMQTT_BROKER_ENDPOINT "Figure 8-10 (e) The Endpoint"
- #define clientcredentialIOT_THING_NAME "Figure 8-11 (f) thing name"

```

aws_clientcredential.h
2      * FreeRTOS V202012.00
25
26  #ifndef __AWS_CLIENTCREDENTIAL_H__
27  #define __AWS_CLIENTCREDENTIAL_H__
28
29  /*
30  * @brief MQTT Broker endpoint.
31  *
32  * @todo Set this to the fully-qualified DNS name of your MQTT broker.
33  */
34  #define clientcredentialMQTT_BROKER_ENDPOINT "██████████.iot.ap-northeast-1.amazonaws.com"
35
36  /*
37  * @brief Host name.
38  *
39  * @todo Set this to the unique name of your IoT Thing.
40  * Please note that for convenience of demonstration only we
41  * are using a #define here. In production scenarios the thing
42  * name can be something unique to the device that can be read
43  * by software, such as a production serial number, rather
44  * than a hard coded constant.
45  */
46  #define clientcredentialIOT_THING_NAME "██████████"
47
    
```

Figure 8-12 Input the endpoint and thing name

14. Open "Certificate Configuration Tool"

- Move to the FreeRTOS path downloaded in 8.1 step 5.
- Open [tools] → [certificate_configuration] → CertificateConfigurator.html
- Import certificate PEM file and Private Key PEM file which were downloaded on 1.1 step (4) of "How to implement FreeRTOS OTA by using Amazon Web Services on RX65N"
- Generate awa_clientcredential_keys.h.

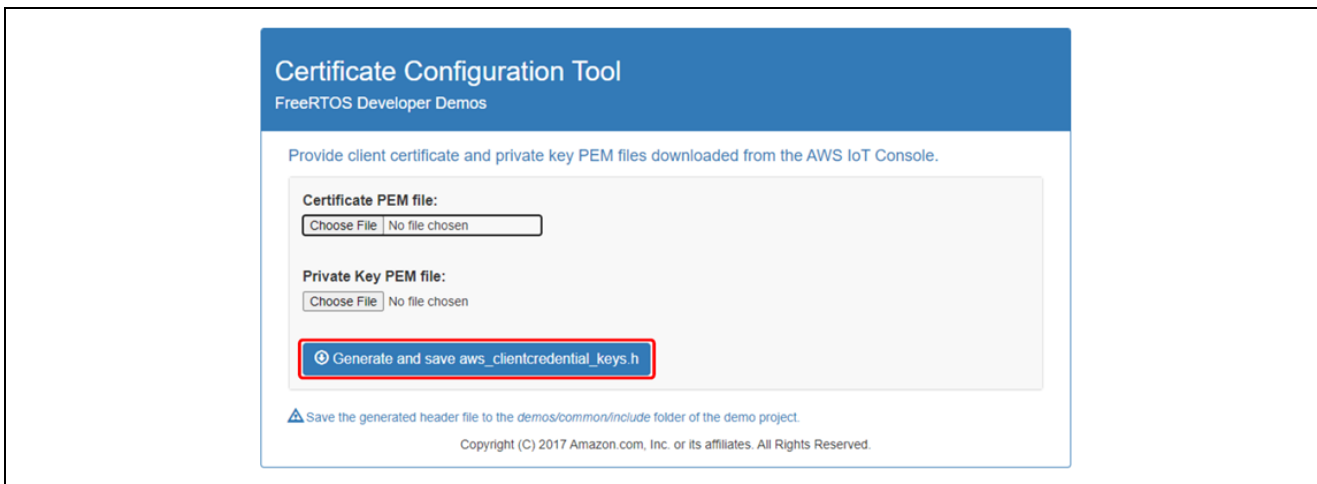

Figure 8-13 Generate clientcredential key

15. Open aws_demos project again

—Replace the aws_clientcredential_keys.h generated above with the file in /demos/include/.

—Open /demos/include/aws_ota_codesigner_certificate.h specify values below

signingcredentialSIGNING_CRETIFICATE_PEM [] = "xxxx";

"xxxx" is value from secp256r1.crt. Remember the "\n" after each line of certification.

For creating secp256r1.crt please refer to "How to implement FreeRTOS OTA by using Amazon web Services on RX65N" section "7.3 Generating ECDSA-SHA256 Key Pairs with OpenSSL".

```

aws_ota_codesigner_certificate.h
* FreeRTOS V202012.00
2
25
26 #ifndef __AWS_CODESIGN_KEYS_H__
27 #define __AWS_CODESIGN_KEYS_H__
28
29 /*
30  * PEM-encoded code signer certificate
31  *
32  * Must include the PEM header and footer:
33  * "-----BEGIN CERTIFICATE-----\n"
34  * "...base64 data...\n"
35  * "-----END CERTIFICATE-----\n";
36  */
37 static const char signingcredentialSIGNING_CERTIFICATE_PEM[] =
38 "-----BEGIN CERTIFICATE-----\n\"
39
40
41
42
43
44
45
46
47
48
49
50
51 "KVBN+xcN\n\"
52 "-----END CERTIFICATE-----\n";
53
54 #endif
55
    
```

Figure 8-14 Input clientcredential

8.3 Install the initial version of firmware

1. Check the FreeRTOSApplicationConfig.h setting.

```

FreeRTOSApplicationConfig.h
1  #ifndef FREERTOS_APPLICATION_CONFIG_H
2  #define FREERTOS_APPLICATION_CONFIG_H
3
4  #define OTA (Used)
5
6  #define Used (1)
7  #define Unused (0)
8
9  #define CONNECTION (WIFI)
10
11 #define ETHER (1)
12 #define WIFI (0)
13
14 #if (CONNECTION == 1)
15 #error "Connection type ETHER not supported"
16 #endif
17
18 #endif
    
```

Figure 8-15 Check Setup

2. Open amazon-freertos/demos/include/ aws_application_version.h, set initial version of firmware to 0.90.

```

aws_application_version.h
2  * FreeRTOS V202012.00
25
26 #ifndef _AWS_APPLICATION_VERSION_H_
27 #define _AWS_APPLICATION_VERSION_H_
28
29 #include "iot_appversion32.h"
30 extern const AppVersion32_t xAppFirmwareVersion;
31
32 #define APP_VERSION_MAJOR (0U)
33 #define APP_VERSION_MINOR (9U)
34 #define APP_VERSION_BUILD (0U)
35
36 #endif
37
    
```

Figure 8-16 Firmware initial version definition

3. Open Section Viewer by selecting [Project] → [Properties] → [C / C ++ Build] → [Settings] → [Tool Settings] tab → [Linker] → [Section] → [...] and change section of aws_demos as following picture.

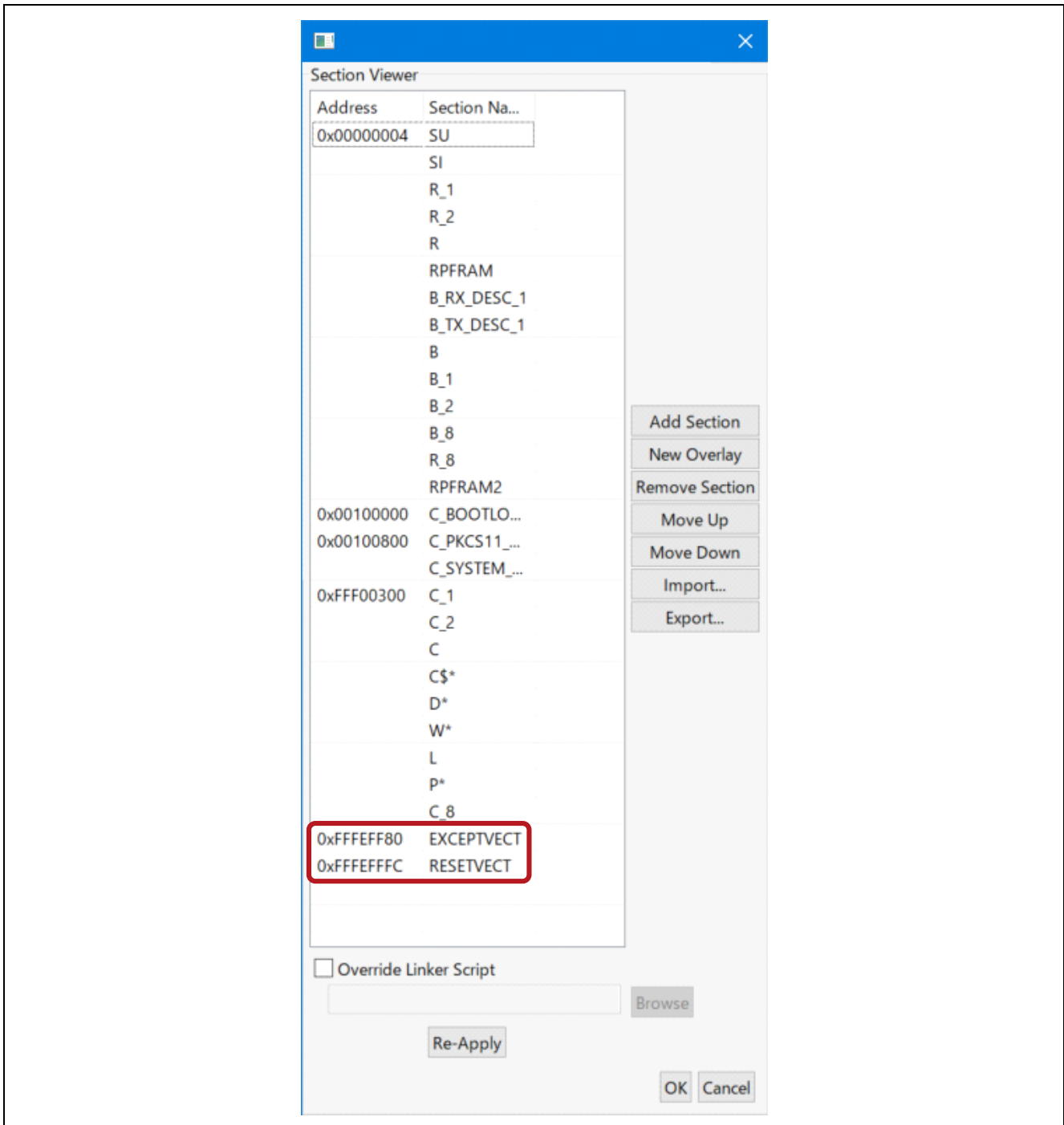

Figure 8-17 Section Settings

4. Build to create aws_demos.mot file.

5. Create userprog.mot from Renesas Secure Flash Programmer.

userprog.mot is a combination of aws_demos.mot and boot_loader.mot. Users can flash this file to RX671 to install initial firmware.

Download Renesas Secure Flash Programmer release 1.0.1 and open Renesas Secure Flash Programmer.exe. Also downloads other files.

—Select [Initial Firm] tab and then set parameters as following picture.

- Private Key Path : location to secp256r1.privatekey
(¥projects¥renesas¥rx671-rsk¥e2studio¥boot_loader¥HardwareDebug)
- Boot Loader File Path : location to boot_loader.mot
(¥projects¥renesas¥rx671-rsk¥e2studio¥aws_demos¥HardwareDebug)
- Bank 0 User Program File Path : location to aws_demos.mot
(¥projects¥renesas¥rx671-rsk¥e2studio¥aws_demos¥HardwareDebug)

—Select [Generate] to generate userprog.mot and save it in the init_firmware folder.
Check Generate succeeded is displayed.

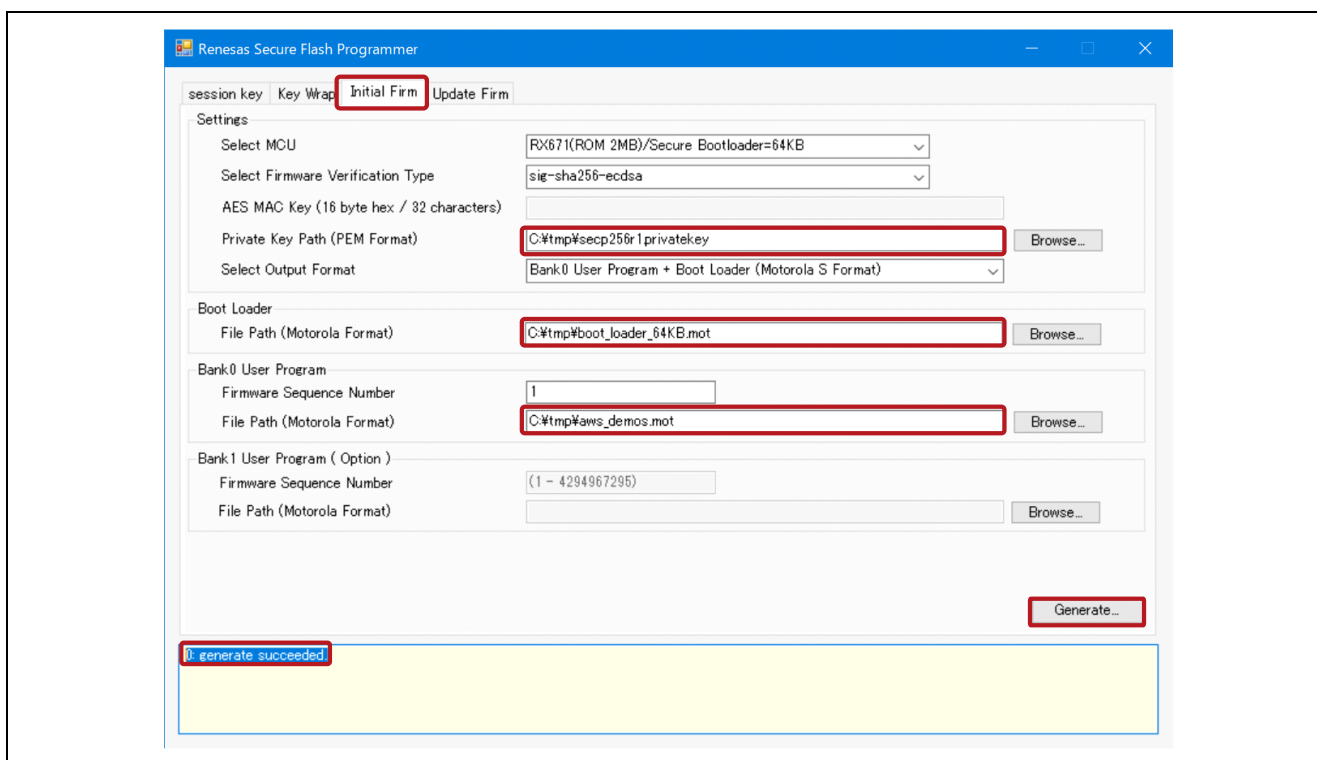

Figure 8-18 Generate userprog.mot

6. Erase the flash ROM of the RX671.

—Download the latest version of Renesas Flash Programmer below.

<https://www.renesas.com/rfp>

—Open the following project in Renesas Flash Programmer.

¥vendors¥renesas¥rx_mcu_boards¥boards¥rx671-rsk¥aws_demos¥flash_project

¥erase_from_bank¥erase.rpj

—Select [Operation] tab and click [Start] to erase the flash ROM.

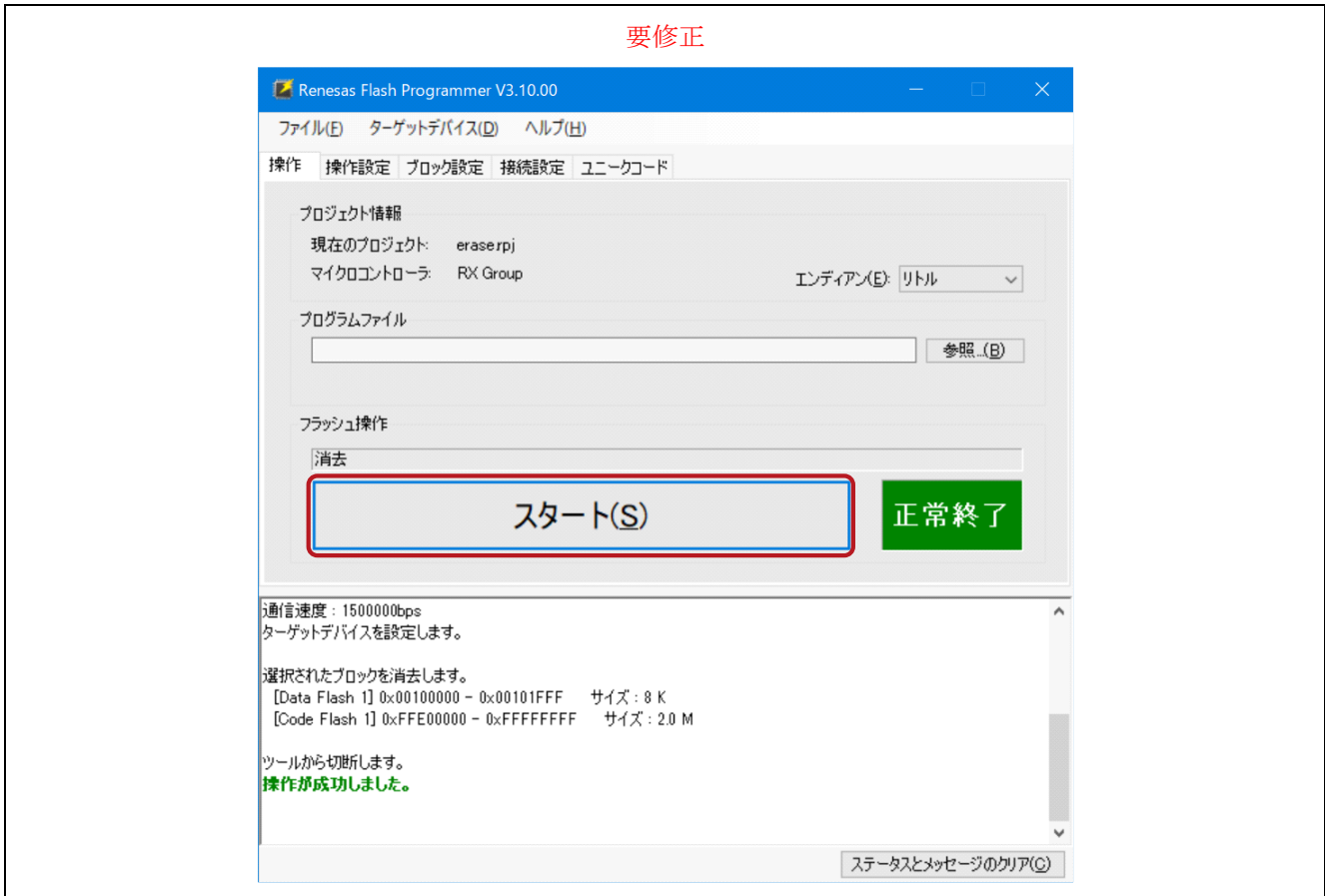

Figure 8-19 Flash ROM erase

7. Write initial firmware on RX671.

- Create a new project with Renesas Flash Programmer (Ex : flash_project.rpj)
- Select [Operation] tab and set userprog.mot stored in the init_firmware folder of the Program File.
- Click [Start].

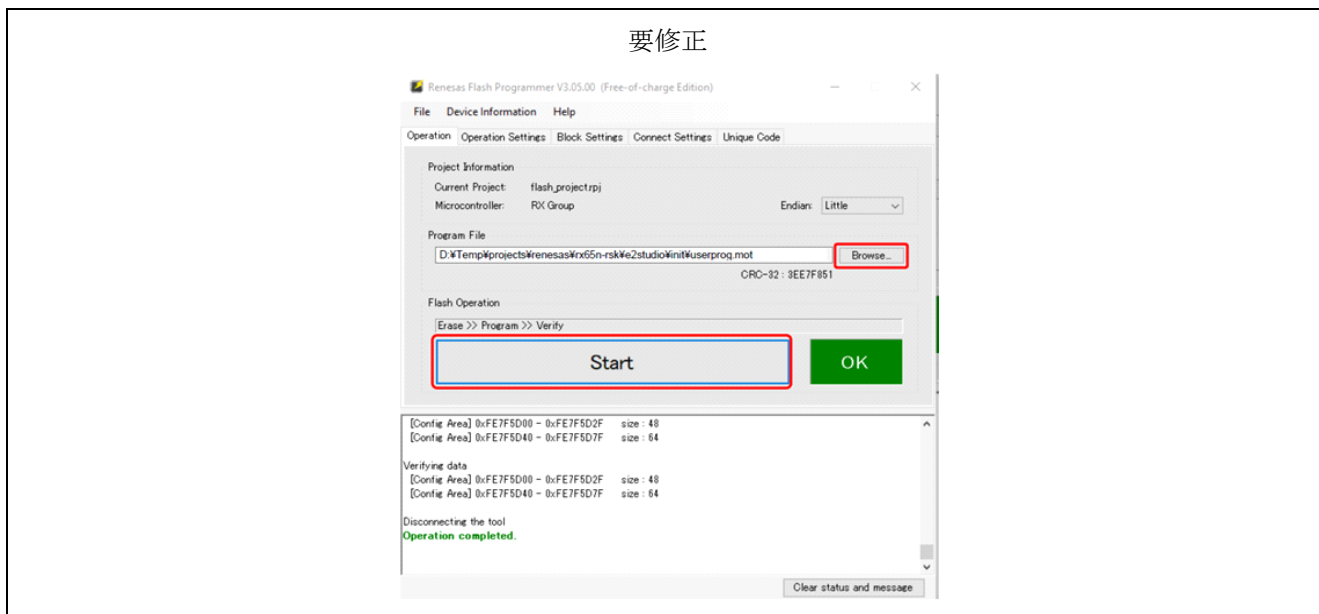

Figure 8-20 Writing initial firmware

8. Open Tera Term

The Tera Term setup is shown below.

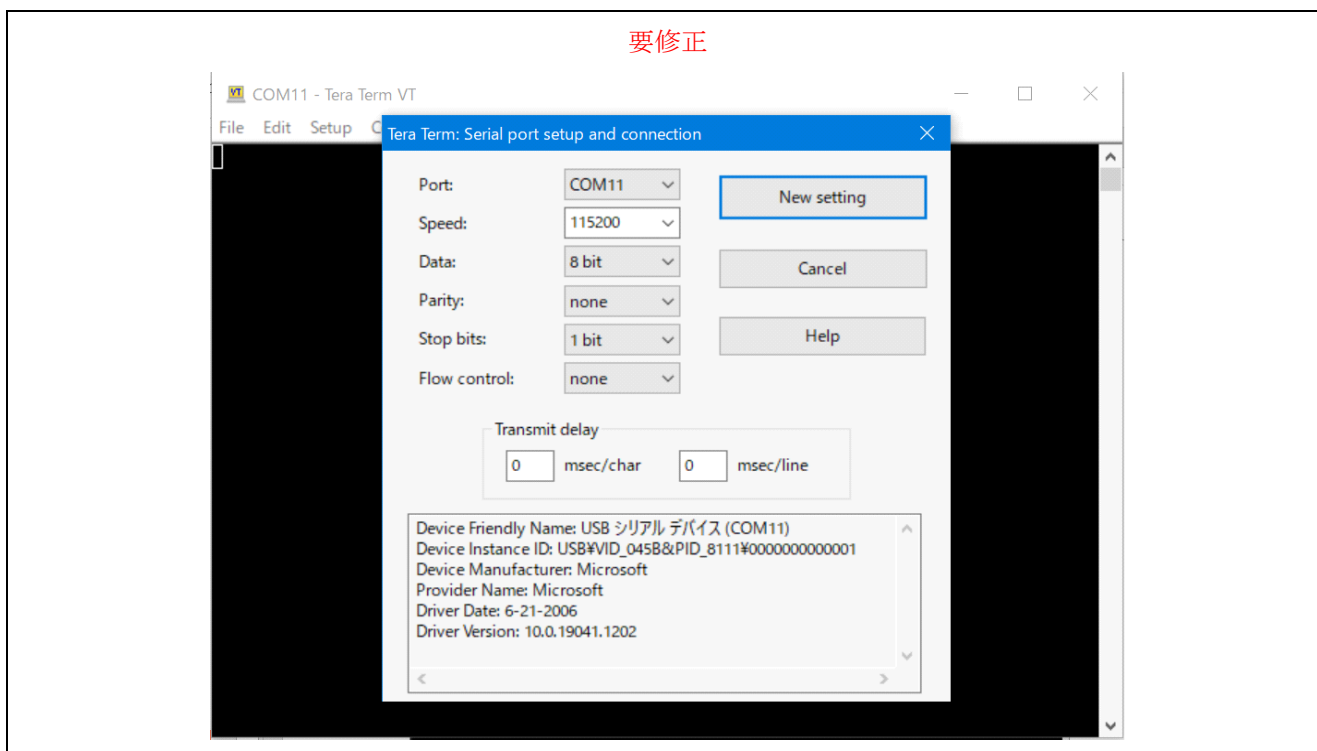

Figure 8-21 Tera Term

Version 0.90 (initial version) is installed in RX671. RX671 is now ready to receive OTA updates. The output log is shown below.

```
-----
RX671 secure boot program
-----
```

```
Checking data flash ROM status.
Loading user code signer public key: not found.
provision the user code signer public key: OK.
Checking code flash ROM status.
bank 0 status = 0xfc [LIFECYCLE_STATE_INITIAL_FIRM_INSTALLED]
bank 1 status = 0xff [LIFECYCLE_STATE_BLANK]
bank info = 1. (start bank = 0)
started 10us software timer using CMT channel 0.
integrity check scheme = sig-sha256-ecdsa
bank0(execute area) on code flash integrity check...OK
erase bank1 secure boot mirror area...OK
OK
copy secure boot (part2) from bank0 to bank1...OK
jump to user program
0 83 [Tmr Svc] [DEBUG] [PKCS11] [core_pkcs11_mbedtls.c:449] 1 83 [Tmr Svc] PKCS #11
module was successfully initialized.2 83 [Tmr Svc]
3 83 [Tmr Svc] [INFO] [PKCS11] [core_pkcs11_mbedtls.c:1504] 4 83 [Tmr Svc] PKCS #11
successfully initialized.5 83 [Tmr Svc]
6 83 [Tmr Svc] [DEBUG] [PKCS11] [core_pkcs11_mbedtls.c:1717] 7 83 [Tmr Svc] Successfully
Returned a PKCS #11 slot with ID 1 with a count of 1.8 83 [Tmr Svc]
9 83 [Tmr Svc] [WARN] [PKCS11] [core_pkcs11_mbedtls.c:1749] 10 83 [Tmr Svc]
C_GetTokenInfo is not implemented.11 83 [Tmr Svc]
12 83 [Tmr Svc] [WARN] [PKCS11] [core_pkcs11_mbedtls.c:1839] 13 83 [Tmr Svc] C_InitToken
is not implemented.14 83 [Tmr Svc]
70 373 [Tmr Svc] [DEBUG] [PKCS11] [core_pkcs11_mbedtls.c:471] 71 373 [Tmr Svc]
Successfully found object class attribute.72 373 [Tmr Svc]
73 373 [Tmr Svc] [INFO] [PKCS11] [core_pkcs11_mbedtls.c:2638] 74 373 [Tmr Svc] Creating a
0x3 type object.75 373 [Tmr Svc]
```

```
76 373 [Tmr Svc] [DEBUG] [PKCS11] [core_pkcs11_mbedtls.c:2158] 77 373 [Tmr Svc]
Successfully found the key type in the template.78 374 [Tmr Svc]
79 374 [Tmr Svc] [DEBUG] [PKCS11] [core_pkcs11_mbedtls.c:2187] 80 374 [Tmr Svc]
Successfully found the label in the template.81 374 [Tmr Svc]
82 374 [Tmr Svc] [DEBUG] [PKCS11] [core_pkcs11_mbedtls.c:1243] 83 374 [Tmr Svc] Key was
private type.84 374 [Tmr Svc]
91 660 [Tmr Svc] [INFO] [PKCS11] [core_pkcs11_mbedtls.c:2033] 92 660 [Tmr Svc]
Successfully closed PKCS #11 session.93 660 [Tmr Svc]
94 663 [iot_thread] [INFO ][DEMO][663] -----STARTING DEMO-----

95 663 [iot_thread] [INFO ][INIT][663] SDK successfully initialized.
96 107527 [iot_thread] [INFO ][DEMO][107527] Successfully initialized the demo. Network
type for the demo: 1
97 107527 [iot_thread] [INFO ][MQTT][107527] MQTT library successfully initialized.
98 107527 [iot_thread] [INFO ][DEMO][107527] OTA demo version 0.9.0

99 107527 [iot_thread] [INFO ][DEMO][107527] Connecting to broker...

100 107527 [iot_thread] [INFO ][DEMO][107527] MQTT demo client identifier is rx671_POC
(length 9).
101 109439 [iot_thread] [WARN] [PKCS11] [core_pkcs11_mbedtls.c:1499] 102 109439
[iot_thread] Failed to initialize PKCS #11. PKCS #11 was already initialized.103 109439
[iot_thread]
104 109439 [iot_thread] [DEBUG] [PKCS11] [core_pkcs11_mbedtls.c:1717] 105 109439
[iot_thread] Successfully Returned a PKCS #11 slot with ID 1 with a count of 1.106 109439
[iot_thread]
107 109439 [iot_thread] [DEBUG] [PKCS11] [core_pkcs11_mbedtls.c:1953] 108 109439
[iot_thread] Assigned a 0x2 Type Session.109 109439 [iot_thread]
110 109439 [iot_thread] [DEBUG] [PKCS11] [core_pkcs11_mbedtls.c:1964] 111 109439
[iot_thread] Assigned Mechanisms to no operation in progress.112 109439 [iot_thread]
113 109439 [iot_thread] [DEBUG] [PKCS11] [core_pkcs11_mbedtls.c:1980] 114 109439
[iot_thread] Current session count at 0115 109439 [iot_thread]
167 111156 [iot_thread] [DEBUG] [PKCS11] [core_pkcs11_mbedtls.c:1073] 168 111156
[iot_thread] Found object in list by handle.169 111156 [iot_thread]
170 111156 [iot_thread] [DEBUG] [PKCS11] [core_pkcs11_mbedtls.c:3780] 171 111157
[iot_thread] Successfully started sign operation.172 111157 [iot_thread]
173 112138 [iot_thread] [DEBUG] [PKCS11] [core_pkcs11_mbedtls.c:3966] 174 112138
[iot_thread] Ended Sign operation.175 112138 [iot_thread]
176 112223 [iot_thread] [INFO ][MQTT][112223] Establishing new MQTT connection.
177 112223 [iot_thread] [INFO ][MQTT][112223] (MQTT connection 23f18, CONNECT operation
240b8) Waiting for operation completion.
178 112351 [NetRecv] [INFO ][MQTT] [core_mqtt_serializer.c:970] 179 112351 [NetRecv]
CONNACK session present bit not set.180 112351 [NetRecv]
181 112351 [NetRecv] [INFO ][MQTT] [core_mqtt_serializer.c:912] 182 112351 [NetRecv]
Connection accepted.183 112351 [NetRecv] no
184 112351 [iot_thread] [INFO ][MQTT][112351] (MQTT connection 23f18, CONNECT operation
240b8) Wait complete with result SUCCESS.
185 112351 [iot_thread] [INFO ][MQTT][112351] New MQTT connection 6a54 established.
186 112353 [iot_thread] [OTA_AgentInit_internal] OTA Task is Ready.
187 112353 [OTA Agent T] [prvPAL_GetPlatformImageState] is called.
188 112353 [OTA Agent T] Function call: prvPAL_GetPlatformImageState: [2]
189 112353 [OTA Agent T] [prvExecuteHandler] Called handler. Current State [Ready] Event
[Start] New state [RequestingJob]
190 112358 [OTA Agent T] [INFO ][MQTT][112358] (MQTT connection 23f18) SUBSCRIBE
operation scheduled.
191 112358 [OTA Agent T] [INFO ][MQTT][112358] (MQTT connection 23f18, SUBSCRIBE
operation 2a960) Waiting for operation completion.
192 112473 [OTA Agent T] [INFO ][MQTT][112473] (MQTT connection 23f18, SUBSCRIBE
operation 2a960) Wait complete with result SUCCESS.
193 112473 [OTA Agent T] [prvSubscribeToJobNotificationTopics] OK:
$aws/things/rx671_POC/jobs/$next/get/accepted
194 112478 [OTA Agent T] [INFO ][MQTT][112478] (MQTT connection 23f18) SUBSCRIBE
operation scheduled.
195 112478 [OTA Agent T] [INFO ][MQTT][112478] (MQTT connection 23f18, SUBSCRIBE
operation 241f8) Waiting for operation completion.
196 112585 [OTA Agent T] [INFO ][MQTT][112585] (MQTT connection 23f18, SUBSCRIBE
operation 241f8) Wait complete with result SUCCESS.
```

```
197 112585 [OTA Agent T] [prvSubscribeToJobNotificationTopics] OK:
$aws/things/rx671_POC/jobs/notify-next
198 112585 [OTA Agent T] [prvRequestJob_Mqtt] Request #0
199 112594 [OTA Agent T] [INFO ][MQTT][112594] (MQTT connection 23f18) MQTT PUBLISH
operation queued.
200 112594 [OTA Agent T] [INFO ][MQTT][112594] (MQTT connection 23f18, PUBLISH operation
241f8) Waiting for operation completion.
201 112670 [OTA Agent T] [INFO ][MQTT][112670] (MQTT connection 23f18, PUBLISH operation
241f8) Wait complete with result SUCCESS.
202 112670 [OTA Agent T] [prvExecuteHandler] Called handler. Current State
[RequestingJob] Event [RequestJobDocument] New state [WaitingForJob]
203 112672 [OTA Agent T] [prvParseJSONbyModel] Extracted parameter [ clientToken:
0:rx671_POC ]
204 112672 [OTA Agent T] [prvParseJSONbyModel] Extracted parameter [ timestamp:
1662611090 ]
205 112672 [OTA Agent T] [prvParseJSONbyModel] parameter not present: execution
206 112672 [OTA Agent T] [prvParseJSONbyModel] parameter not present: jobId
207 112672 [OTA Agent T] [prvParseJSONbyModel] parameter not present: jobDocument
208 112672 [OTA Agent T] [prvParseJSONbyModel] parameter not present: afr_ota
209 112672 [OTA Agent T] [prvParseJSONbyModel] parameter not present: protocols
210 112672 [OTA Agent T] [prvParseJSONbyModel] parameter not present: files
211 112672 [OTA Agent T] [prvParseJSONbyModel] parameter not present: filepath
212 112672 [OTA Agent T] [prvParseJSONbyModel] parameter not present: filesize
213 112672 [OTA Agent T] [prvParseJSONbyModel] parameter not present: fileId
214 112672 [OTA Agent T] [prvParseJSONbyModel] parameter not present: certfile
215 112672 [OTA Agent T] [prvParseJSONbyModel] parameter not present: sig-sha256-ecdsa
216 112672 [OTA Agent T] [prvParseJobDoc] No active jobs available in the service for
execution.
217 112674 [OTA Agent T] [prvParseJobDoc] Ignoring job without ID.
222 113353 [iot_thread] [INFO ][DEMO][113353] State: Ready Received: 1 Queued: 0
Processed: 0 Dropped: 0

223 114353 [iot_thread] [INFO ][DEMO][114353] State: WaitingForJob Received: 1 Queued:
0 Processed: 0 Dropped: 0

224 115353 [iot_thread] [INFO ][DEMO][115353] State: WaitingForJob Received: 1 Queued:
0 Processed: 0 Dropped: 0

225 116353 [iot_thread] [INFO ][DEMO][116353] State: WaitingForJob Received: 1 Queued:
0 Processed: 0 Dropped: 0

226 117353 [iot_thread] [INFO ][DEMO][117353] State: WaitingForJob Received: 1 Queued:
0 Processed: 0 Dropped: 0

227 118353 [iot_thread] [INFO ][DEMO][118353] State: WaitingForJob Received: 1 Queued:
0 Processed: 0 Dropped: 0
```

9. Restriction

This section describes restriction for this application note.

- FreeRTOS OTA programs with big endian operate abnormally.
Build and operate programs with little endian.

10. Reference Documents

- RX671Group User's Manual: Hardware (R01UH0905)
- Renesas Starter Kit+ for RX671User's Manual (R20UT4879)
- RX Family Using QE and FIT to Develop Capacitive Touch Applications (R01AN4516)
- RX Family QE for Display GUI Display Application Development Guide using Serial Connection LCD (R20AN0688)
- Renesas MCU Firmware Update Design Policy (R01AN5548)
- How to implement FreeRTOS OTA by using Amazon Web Serviceson RX65N (R01AN5549)
- RX671 Group Renesas Starter Kit+ for RX671 User's Manual (R20UT4879EG0101)

The latest version can be downloaded from the Renesas Electronics website.

All trademarks and registered trademarks are the property of their respective owners.

Revision History

Rev.	Date	Description	
		Page	Summary
1.00	Apr.24.23	-	First edition

General Precautions in the Handling of Microprocessing Unit and Microcontroller Unit Products

The following usage notes are applicable to all Microprocessing unit and Microcontroller unit products from Renesas. For detailed usage notes on the products covered by this document, refer to the relevant sections of the document as well as any technical updates that have been issued for the products.

1. Precaution against Electrostatic Discharge (ESD)

A strong electrical field, when exposed to a CMOS device, can cause destruction of the gate oxide and ultimately degrade the device operation. Steps must be taken to stop the generation of static electricity as much as possible, and quickly dissipate it when it occurs. Environmental control must be adequate. When it is dry, a humidifier should be used. This is recommended to avoid using insulators that can easily build up static electricity.

Semiconductor devices must be stored and transported in an anti-static container, static shielding bag or conductive material. All test and measurement tools including work benches and floors must be grounded. The operator must also be grounded using a wrist strap. Semiconductor devices must not be touched with bare hands. Similar precautions must be taken for printed circuit boards with mounted semiconductor devices.

2. Processing at power-on

The state of the product is undefined at the time when power is supplied. The states of internal circuits in the LSI are indeterminate and the states of register settings and pins are undefined at the time when power is supplied. In a finished product where the reset signal is applied to the external reset pin, the states of pins are not guaranteed from the time when power is supplied until the reset process is completed. In a similar way, the states of pins in a product that is reset by an on-chip power-on reset function are not guaranteed from the time when power is supplied until the power reaches the level at which resetting is specified.

3. Input of signal during power-off state

Do not input signals or an I/O pull-up power supply while the device is powered off. The current injection that results from input of such a signal or I/O pull-up power supply may cause malfunction and the abnormal current that passes in the device at this time may cause degradation of internal elements. Follow the guideline for input signal during power-off state as described in your product documentation.

4. Handling of unused pins

Handle unused pins in accordance with the directions given under handling of unused pins in the manual. The input pins of CMOS products are generally in the high-impedance state. In operation with an unused pin in the open-circuit state, extra electromagnetic noise is induced in the vicinity of the LSI, an associated shoot-through current flows internally, and malfunctions occur due to the false recognition of the pin state as an input signal become possible.

5. Clock signals

After applying a reset, only release the reset line after the operating clock signal becomes stable. When switching the clock signal during program execution, wait until the target clock signal is stabilized. When the clock signal is generated with an external resonator or from an external oscillator during a reset, ensure that the reset line is only released after full stabilization of the clock signal. Additionally, when switching to a clock signal produced with an external resonator or by an external oscillator while program execution is in progress, wait until the target clock signal is stable.

6. Voltage application waveform at input pin

Waveform distortion due to input noise or a reflected wave may cause malfunction. If the input of the CMOS device stays in the area between V_{IL} (Max.) and V_{IH} (Min.) due to noise, for example, the device may malfunction. Take care to prevent chattering noise from entering the device when the input level is fixed, and also in the transition period when the input level passes through the area between V_{IL} (Max.) and V_{IH} (Min.).

7. Prohibition of access to reserved addresses

Access to reserved addresses is prohibited. The reserved addresses are provided for possible future expansion of functions. Do not access these addresses as the correct operation of the LSI is not guaranteed.

8. Differences between products

Before changing from one product to another, for example to a product with a different part number, confirm that the change will not lead to problems. The characteristics of a microprocessing unit or microcontroller unit products in the same group but having a different part number might differ in terms of internal memory capacity, layout pattern, and other factors, which can affect the ranges of electrical characteristics, such as characteristic values, operating margins, immunity to noise, and amount of radiated noise. When changing to a product with a different part number, implement a system-evaluation test for the given product.

Notice

1. Descriptions of circuits, software and other related information in this document are provided only to illustrate the operation of semiconductor products and application examples. You are fully responsible for the incorporation or any other use of the circuits, software, and information in the design of your product or system. Renesas Electronics disclaims any and all liability for any losses and damages incurred by you or third parties arising from the use of these circuits, software, or information.
2. Renesas Electronics hereby expressly disclaims any warranties against and liability for infringement or any other claims involving patents, copyrights, or other intellectual property rights of third parties, by or arising from the use of Renesas Electronics products or technical information described in this document, including but not limited to, the product data, drawings, charts, programs, algorithms, and application examples.
3. No license, express, implied or otherwise, is granted hereby under any patents, copyrights or other intellectual property rights of Renesas Electronics or others.
4. You shall be responsible for determining what licenses are required from any third parties, and obtaining such licenses for the lawful import, export, manufacture, sales, utilization, distribution or other disposal of any products incorporating Renesas Electronics products, if required.
5. You shall not alter, modify, copy, or reverse engineer any Renesas Electronics product, whether in whole or in part. Renesas Electronics disclaims any and all liability for any losses or damages incurred by you or third parties arising from such alteration, modification, copying or reverse engineering.
6. Renesas Electronics products are classified according to the following two quality grades: "Standard" and "High Quality". The intended applications for each Renesas Electronics product depends on the product's quality grade, as indicated below.
 - "Standard": Computers; office equipment; communications equipment; test and measurement equipment; audio and visual equipment; home electronic appliances; machine tools; personal electronic equipment; industrial robots; etc.
 - "High Quality": Transportation equipment (automobiles, trains, ships, etc.); traffic control (traffic lights); large-scale communication equipment; key financial terminal systems; safety control equipment; etc.Unless expressly designated as a high reliability product or a product for harsh environments in a Renesas Electronics data sheet or other Renesas Electronics document, Renesas Electronics products are not intended or authorized for use in products or systems that may pose a direct threat to human life or bodily injury (artificial life support devices or systems; surgical implantations; etc.), or may cause serious property damage (space system; undersea repeaters; nuclear power control systems; aircraft control systems; key plant systems; military equipment; etc.). Renesas Electronics disclaims any and all liability for any damages or losses incurred by you or any third parties arising from the use of any Renesas Electronics product that is inconsistent with any Renesas Electronics data sheet, user's manual or other Renesas Electronics document.
7. No semiconductor product is absolutely secure. Notwithstanding any security measures or features that may be implemented in Renesas Electronics hardware or software products, Renesas Electronics shall have absolutely no liability arising out of any vulnerability or security breach, including but not limited to any unauthorized access to or use of a Renesas Electronics product or a system that uses a Renesas Electronics product. RENESAS ELECTRONICS DOES NOT WARRANT OR GUARANTEE THAT RENESAS ELECTRONICS PRODUCTS, OR ANY SYSTEMS CREATED USING RENESAS ELECTRONICS PRODUCTS WILL BE INVULNERABLE OR FREE FROM CORRUPTION, ATTACK, VIRUSES, INTERFERENCE, HACKING, DATA LOSS OR THEFT, OR OTHER SECURITY INTRUSION ("Vulnerability Issues"). RENESAS ELECTRONICS DISCLAIMS ANY AND ALL RESPONSIBILITY OR LIABILITY ARISING FROM OR RELATED TO ANY VULNERABILITY ISSUES. FURTHERMORE, TO THE EXTENT PERMITTED BY APPLICABLE LAW, RENESAS ELECTRONICS DISCLAIMS ANY AND ALL WARRANTIES, EXPRESS OR IMPLIED, WITH RESPECT TO THIS DOCUMENT AND ANY RELATED OR ACCOMPANYING SOFTWARE OR HARDWARE, INCLUDING BUT NOT LIMITED TO THE IMPLIED WARRANTIES OF MERCHANTABILITY, OR FITNESS FOR A PARTICULAR PURPOSE.
8. When using Renesas Electronics products, refer to the latest product information (data sheets, user's manuals, application notes, "General Notes for Handling and Using Semiconductor Devices" in the reliability handbook, etc.), and ensure that usage conditions are within the ranges specified by Renesas Electronics with respect to maximum ratings, operating power supply voltage range, heat dissipation characteristics, installation, etc. Renesas Electronics disclaims any and all liability for any malfunctions, failure or accident arising out of the use of Renesas Electronics products outside of such specified ranges.
9. Although Renesas Electronics endeavors to improve the quality and reliability of Renesas Electronics products, semiconductor products have specific characteristics, such as the occurrence of failure at a certain rate and malfunctions under certain use conditions. Unless designated as a high reliability product or a product for harsh environments in a Renesas Electronics data sheet or other Renesas Electronics document, Renesas Electronics products are not subject to radiation resistance design. You are responsible for implementing safety measures to guard against the possibility of bodily injury, injury or damage caused by fire, and/or danger to the public in the event of a failure or malfunction of Renesas Electronics products, such as safety design for hardware and software, including but not limited to redundancy, fire control and malfunction prevention, appropriate treatment for aging degradation or any other appropriate measures. Because the evaluation of microcomputer software alone is very difficult and impractical, you are responsible for evaluating the safety of the final products or systems manufactured by you.
10. Please contact a Renesas Electronics sales office for details as to environmental matters such as the environmental compatibility of each Renesas Electronics product. You are responsible for carefully and sufficiently investigating applicable laws and regulations that regulate the inclusion or use of controlled substances, including without limitation, the EU RoHS Directive, and using Renesas Electronics products in compliance with all these applicable laws and regulations. Renesas Electronics disclaims any and all liability for damages or losses occurring as a result of your noncompliance with applicable laws and regulations.
11. Renesas Electronics products and technologies shall not be used for or incorporated into any products or systems whose manufacture, use, or sale is prohibited under any applicable domestic or foreign laws or regulations. You shall comply with any applicable export control laws and regulations promulgated and administered by the governments of any countries asserting jurisdiction over the parties or transactions.
12. It is the responsibility of the buyer or distributor of Renesas Electronics products, or any other party who distributes, disposes of, or otherwise sells or transfers the product to a third party, to notify such third party in advance of the contents and conditions set forth in this document.
13. This document shall not be reprinted, reproduced or duplicated in any form, in whole or in part, without prior written consent of Renesas Electronics.
14. Please contact a Renesas Electronics sales office if you have any questions regarding the information contained in this document or Renesas Electronics products.

(Note1) "Renesas Electronics" as used in this document means Renesas Electronics Corporation and also includes its directly or indirectly controlled subsidiaries.

(Note2) "Renesas Electronics product(s)" means any product developed or manufactured by or for Renesas Electronics.

(Rev.5.0-1 October 2020)

Corporate Headquarters

TOYOSU FORESIA, 3-2-24 Toyosu,
Koto-ku, Tokyo 135-0061, Japan
www.renesas.com

Trademarks

Renesas and the Renesas logo are trademarks of Renesas Electronics Corporation. All trademarks and registered trademarks are the property of their respective owners.

Contact information

For further information on a product, technology, the most up-to-date version of a document, or your nearest sales office, please visit:
www.renesas.com/contact/.