

---

## RX130 Group

### Environmental sensor module control sample software

---

#### Introduction

This application note explains the communication control sample software between “Renesas Starter Kit for RX130-512KB” (RSK), “ZMOD4410” and “HS3001.”

#### Target Device

RX130 Group

#### Related Documents

1. Renesas Starter Kit for RX130 CPU Board Schematics (R20UT3920EG0100)
2. ZMOD44xx-API Documentation (ZMOD44xx-API.pdf)
3. HS300x Datasheet (IDT\_HS300x-Datasheet\_DST\_20180806.pdf)

## Contents

1. Outline .....	3
2. Operation Confirmation Environment .....	3
2.1 Connection Preparation .....	3
2.2 Connection .....	3
2.3 Connection Example .....	4
3. Software Functions .....	5
3.1 Sensor Data .....	5
3.1.1 ZMOD4410 (Gas Sensor) .....	5
3.1.2 HS3001 (Relative Humidity and Temperature Sensor) .....	5
3.2 LCD display .....	6
3.3 Touch control .....	6
4. Smart Configurator Modules .....	7
4.1 Module Lists .....	7
5. Software Specifications .....	8
5.1 Software Structure .....	8
5.2 File Structure .....	9
5.3 How to get the ZMOD4410 library .....	10
5.4 API Function Specifications .....	11
5.4.1 R_HS3000_Init .....	11
5.4.2 R_HS3000_RequestMeasurement .....	11
5.4.3 R_HS3000_GetReady .....	11
5.4.4 R_HS3000_GetData .....	12
5.4.5 R_ZMOD4410_Init .....	12
5.4.6 R_ZMOD4410_GetData .....	12
Revision History .....	13

## 1. Outline

This software is communication control sample software of Renesas Starter Kit for RX130-512KB (RSK), ZMOD4410(Gas Sensor) and HS3001(Relative Humidity and Temperature Sensor).

The RX Microcomputer gets data of ZMOD4410 and HS3001 through I2C communication and display it on the RSK LCD.

## 2. Operation Confirmation Environment

Table2.1 lists the confirmed operation conditions for this software.

**Table 2.1 Operation Confirmation Environment**

Item	Description
Evaluation board	RTK50051308C00000BE
MCU used	RX130-512KB (R5F51308ADFP)
Operating frequency	32MHz
Operating voltage	5.0V
Humidity and Temperature sensor module	HS3001 Sensor Modules
Gas Sensor module	ZMOD4410 Sensor Board
Integrated Development Environment	e <sup>2</sup> Studio v7.6.0
C compiler	CC-RX v3.01.00

### 2.1 Connection Preparation

Power supply for ZMOD4410 and HS3001 is 3.3V supplied by RSK.

Confirm setting for RSK JA1 connector, SDA and SCL pull-up are 3.3V (R16 short/ R23 open).

### 2.2 Connection

Connect sensor modules using JA1 of RSK.

The connection between JA1 of RSK and sensors are as follows.

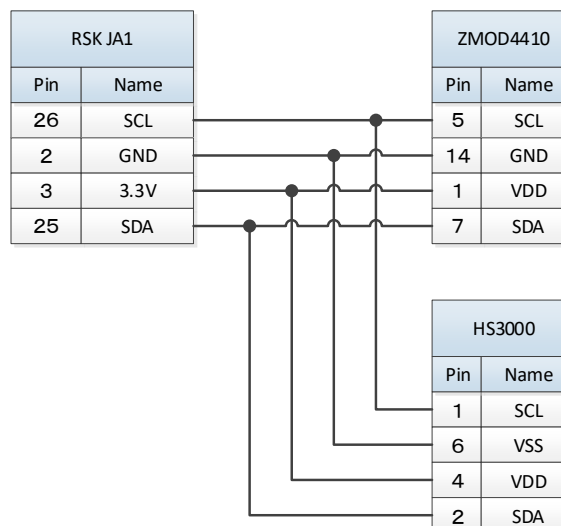

### 2.3 Connection Example

An example of connection between RSK and sensors is shown below.

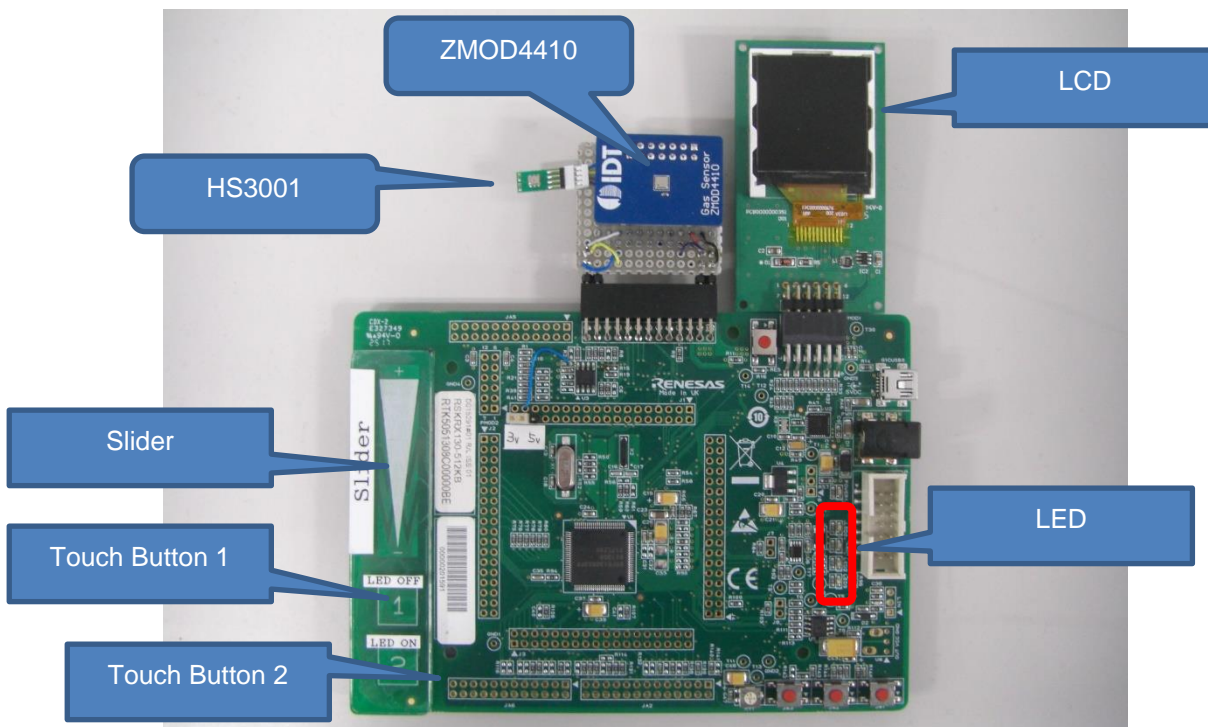

Figure 2.1 Example of connection between RSK and Sensors

### 3. Software Functions

This software features the following functions

1. Sensor control (Initialize, get data, set data)
2. Display LDC of sensor data
3. Capacitive Touch control (LED On/Off when controlling Capacitive touch)

#### 3.1 Sensor Data

This chapter explains the process of getting data from sensors.

##### 3.1.1 ZMOD4410 (Gas Sensor)

Start measurement with the library "zmod4xxx\_start\_measurement" and calculate eCO<sub>2</sub>, TVOC and IAQ with the library "calc\_iaq\_2nd\_gen" using the data returned from ZMOD4410 with "zmod4xxx\_read\_adc\_result."

(See related document 2)

##### 3.1.2 HS3001 (Relative Humidity and Temperature Sensor)

From HS3001, 4 bytes of data are getting returned in the following order.

Humidity (Humidity Data [13:8]), Humidity (Humidity data[7:0]), Temperature (Temp Data[15:8]),  
Temperature (Temp Data[7:2])

Calculate those data by below formula. (See related document 3)

$$\text{Humidity} [\%RH] = \left( \frac{\text{Humidity} [13:0]}{2^{14} - 1} \right) * 100$$

$$\text{Temperature} [^{\circ}\text{C}] = \left( \frac{\text{Temperature} [15:2]}{2^{14} - 1} \right) * 165 - 40$$

### 3.2 LCD display

Display temperature (TEMP), humidity (RH), eCO2, TVOC, IAQ, on the LCD and update it every two second.

<LCD display example>

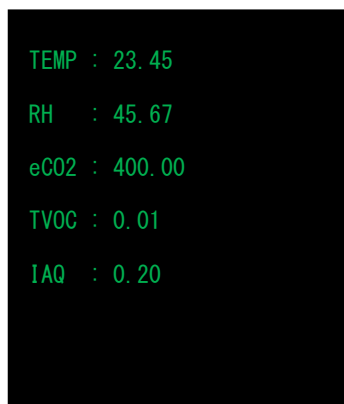

eCO2, TVOC, and IAQ require about 3 minutes before the measured values can be acquired.

ECO2 and TVOC display "0" and IAQ display "1" until the measured value is acquired.

### 3.3 Touch control

Control the LED with touch keys.

At startup, all LEDs are off.

Push touch button1 to turn off all LED. Push touch bottun2 to turn on all LED.

Select which LED to turn on according to the position of the slider.

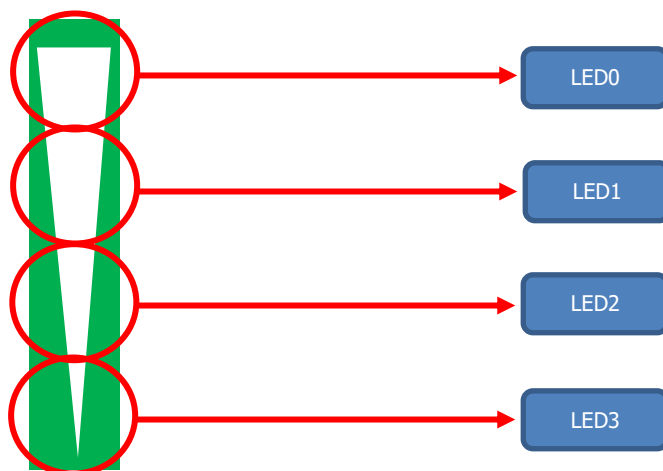

## 4. Smart Configurator Modules

This chapter describes the modules generated by Smart Configurator.

### 4.1 Module Lists

The modules used are as follows.

Folder name	Function	Description
Config_PORT	Set I/O port function	Port Setting
Config_RIIC0	I <sup>2</sup> C bus interface	Sensor Communication
Config_SCI6	Serial communication interface channel 6 (Simple SPI bus)	LCD data transfer
Config_TMR0	8-bit timer channel 0 (1ms interval timer)	initialize completion waiting
Config_TMR1	8-bit timer channel 1 (10ms interval timer)	One second timer
Config_TMR2	8-bit timer channel 2 (1ms interval timer)	sensor processes waiting
r_cmt_rx	Compare match timer FIT module	Touch (Button, Slider)
r_ctsu_eq	CTSU FIT module	Touch (Button, Slider)
r_touch_eq	Touch FIT module	Touch (Button, Slider)

## 5. Software Specifications

### 5.1 Software Structure

Applications are created by using output file from Smart Configurator.

Figure 5.1 shows a diagram of the software structure.

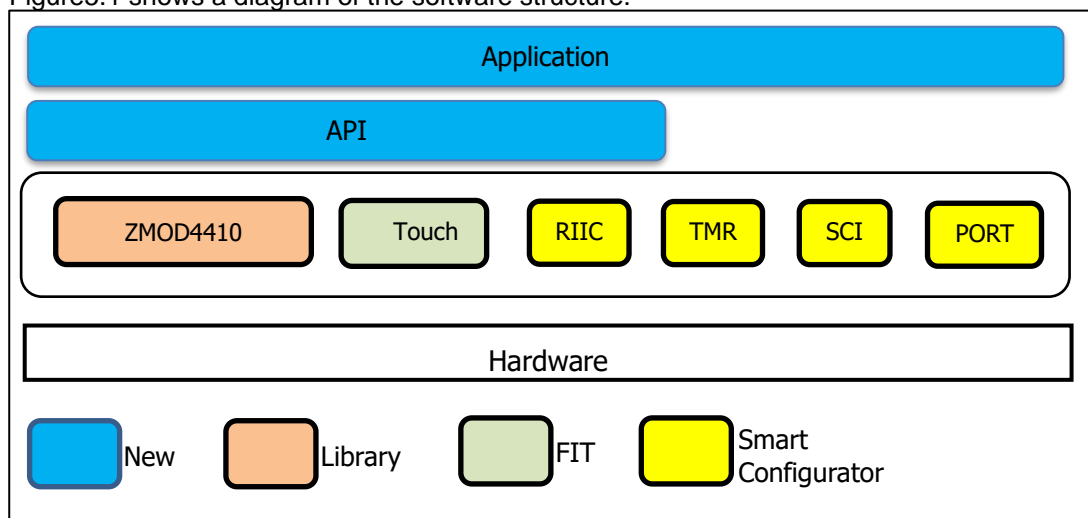

Figure 5.1 Software Structure



## 5.2 File Structure

Table 5.1 shows the source file tree.

Table 5.1 have omitted the files generated by FIT and Smart Configurator for brevity.

**Table 5.1 Source File Tree**

```

|-- workspace
|
|-- RX130
|   |-- SensorApl
|       |-- src
|           | sensor_main.c ..... Application Source file
|           | qe_common.c ..... QE for Capacitive Touch file
|           | qe_common.h ..... QE for Capacitive Touch file
|           | qe_config01.c ..... QE for Capacitive Touch file
|           | qe_config01.h ..... QE for Capacitive Touch file
|           |
|           |-- Pmod ..... LCD Control
|           |
|           |-- Lib_ZMOD44 ..... ZMOD4410 Library
|               (the folder is empty. Refer Chapter5.3 and copy the file)
|           |
|           |-- Sensor
|               r_hs3000_api.c ..... HS3001 source file
|               r_hs3000_api.h ..... HS3001 header file
|               r_i2c_sub.c ..... I2C communication source file
|               r_i2c_sub.h ..... I2C communication header file
|               r_zmod4410_api.c .... ZMOD4410 source file
|               r_zmod4410_api.h .... ZMOD4410 header file
|           |
|           |-- smc_gen ..... Smart Configurator output

```

### 5.3 How to get the ZMOD4410 library

Download the library for ZMOD4410 from below link.

<https://www.idt.com/us/en/products/sensor-products/gas-sensors/zmod4410-indoor-air-quality-sensor-platform>

Require Downloading below one file.

- [ZMOD4410 - 2nd Gen - Air Quality & eCO2 Firmware - Recommended for New Designs](#)

Unzip the downloaded library and copy the following files to the Lib\_ZMOD44 folder.

**Table 5.2 Library File**

Folder	File
ZMOD4410_IAQ_2nd_Gen_Example\ZMOD4410_Firmware \gas-algorithm-libraries\iaq_2nd_gen \Renesas RX\RX100\ccrx\	iaq_2nd_gen.h
	lib_iaq_2nd_gen.lib
	lib_zmod4xxx_cleaning.lib
ZMOD4410_IAQ_2nd_Gen_Example\ZMOD4410_Firmware \zmod4xxx_example\src	zmod4xxx.c
	zmod4xxx.h
	zmod4xxx_types.h
	zmod4410_config_iaq2.h
	zmod4xxx_cleaning.h

## 5.4 API Function Specifications

Following are the specification for API function.

### 5.4.1 R\_HS3000\_Init

Function	HS3001Initialization		
Format	MD_STATUS R_HS3000_Init(void)		
Argument	-	-	-
Return value	MD_OK MD_ERROR MD_ARGERROR MD_ERROR1 MD_ERROR2 MD_ERROR3	Successful completion Abnormal completion Argument error Arbitration lost Timeout NACK received	
Description	Return MD_OK after initialization.		
Note	-		

### 5.4.2 R\_HS3000\_RequestMeasurement

Function	HS3001 Request Measurement		
Format	MD_STATUS R_HS3000_RequestMeasurement(void)		
Argument	-	-	-
Return value	MD_OK MD_ERROR MD_ARGERROR MD_ERROR1 MD_ERROR2 MD_ERROR3 MD_BUSY2	Successful completion Abnormal completion Argument error Arbitration lost Timeout NACK received Processing	
Description	Start measurement and timer count. Interval timer is 2 seconds.		
Note	Repeat until the return value is other than MD_BUSY2. If the return value is MD_OK, repeat until R_SH3000_GetReady() is MD_OK.		

### 5.4.3 R\_HS3000\_GetReady

Function	HS3001 Status getting		
Format	MD_STATUS R_HS3000_GetReady(void)		
Argument	-	-	-
Return value	MD_OK MD_ERROR MD_ARGERROR MD_ERROR1 MD_ERROR2 MD_ERROR3 MD_BUSY2	Successful completion Abnormal completion Argument error Arbitration lost Timeout NACK received Processing	
Description	Return MD_OK when the timer of R_HS3000_RequestMeasurement() ends.		
Note	Repeat until the return value is other than MD_BUSY1. If the return value is MD_OK, data available by R_HS3000_GetData().		

**5.4.4 R\_HS3000\_GetData**

Function	HS3001 Data getting		
Format	MD_STATUS R_HS3000_GetData(float *temp, float *humi)		
Argument	float * float *	temp humi	Temperature data storage address Humidity data storage address
Return value	MD_OK MD_ERROR MD_ARGERROR MD_ERROR1 MD_ERROR2 MD_ERROR3 MD_BUSY2	Successful completion Abnormal completion Argument error Arbitration lost Timeout NACK received Processing	
Description	This API gets data and calculate the temperature and humidity referring chapter3.1.2 formula and store to the specified address.		
Note	Repeat until the return value is other than MD_BUSY2. If the return value is MD_OK, sensor data is stored at the address specified by the argument.		

**5.4.5 R\_ZMOD4410\_Init**

Function	ZMOD4410 Initialization		
Format	MD_STATUS R_ZMOD4410_Init(void)		
Argument	-	-	-
Return value	MD_OK MD_ERROR MD_ARGERROR MD_ERROR1 MD_ERROR2 MD_ERROR3	Successful completion Abnormal completion Argument error Arbitration lost Timeout NACK received	
Description	Return MD_OK when Initialization completed		
Note	-		

**5.4.6 R\_ZMOD4410\_GetData**

Function	ZMOD4410 Data getting		
Format	MD_STATUS R_ZMOD4410_GetData(float *p_eco2, float *p_tvoc, float p_iaq)		
Argument	float * float * float *	p_eco2 p_tvoc p_iaq	eCO2 data storage address TVOC data storage address IAR data storage address
Return value	MD_OK MD_ERROR MD_ARGERROR MD_ERROR1 MD_ERROR2 MD_ERROR3 MD_BUSY2	Successful completion Abnormal completion Argument error Arbitration lost Timeout NACK received Processing	
Description	Getting data and library proceeded, store the data at the specified address.		
Note	Repeat until the return value is other than MD_BUSY2 If the value is MD_OK, sensor data is stored at the address specified by the argument.		

**Revision History**

Rev.	Date	Description	
		Page	Summary
1.00	Jun.01.20	-	First release
1.10	Aug.31.20	5, 6, 10, 12	Changed Chapter3.1.1, 3.2, 5.3 and 5.4.6 according to the GAS sensor library update.

## General Precautions in the Handling of Microprocessing Unit and Microcontroller Unit Products

The following usage notes are applicable to all Microprocessing unit and Microcontroller unit products from Renesas. For detailed usage notes on the products covered by this document, refer to the relevant sections of the document as well as any technical updates that have been issued for the products.

### 1. Precaution against Electrostatic Discharge (ESD)

A strong electrical field, when exposed to a CMOS device, can cause destruction of the gate oxide and ultimately degrade the device operation. Steps must be taken to stop the generation of static electricity as much as possible, and quickly dissipate it when it occurs. Environmental control must be adequate. When it is dry, a humidifier should be used. This is recommended to avoid using insulators that can easily build up static electricity.

Semiconductor devices must be stored and transported in an anti-static container, static shielding bag or conductive material. All test and measurement tools including work benches and floors must be grounded. The operator must also be grounded using a wrist strap. Semiconductor devices must not be touched with bare hands. Similar precautions must be taken for printed circuit boards with mounted semiconductor devices.

### 2. Processing at power-on

The state of the product is undefined at the time when power is supplied. The states of internal circuits in the LSI are indeterminate and the states of register settings and pins are undefined at the time when power is supplied. In a finished product where the reset signal is applied to the external reset pin, the states of pins are not guaranteed from the time when power is supplied until the reset process is completed. In a similar way, the states of pins in a product that is reset by an on-chip power-on reset function are not guaranteed from the time when power is supplied until the power reaches the level at which resetting is specified.

### 3. Input of signal during power-off state

Do not input signals or an I/O pull-up power supply while the device is powered off. The current injection that results from input of such a signal or I/O pull-up power supply may cause malfunction and the abnormal current that passes in the device at this time may cause degradation of internal elements. Follow the guideline for input signal during power-off state as described in your product documentation.

### 4. Handling of unused pins

Handle unused pins in accordance with the directions given under handling of unused pins in the manual. The input pins of CMOS products are generally in the high-impedance state. In operation with an unused pin in the open-circuit state, extra electromagnetic noise is induced in the vicinity of the LSI, an associated shoot-through current flows internally, and malfunctions occur due to the false recognition of the pin state as an input signal become possible.

### 5. Clock signals

After applying a reset, only release the reset line after the operating clock signal becomes stable. When switching the clock signal during program execution, wait until the target clock signal is stabilized. When the clock signal is generated with an external resonator or from an external oscillator during a reset, ensure that the reset line is only released after full stabilization of the clock signal. Additionally, when switching to a clock signal produced with an external resonator or by an external oscillator while program execution is in progress, wait until the target clock signal is stable.

### 6. Voltage application waveform at input pin

Waveform distortion due to input noise or a reflected wave may cause malfunction. If the input of the CMOS device stays in the area between  $V_{IL}$  (Max.) and  $V_{IH}$  (Min.) due to noise, for example, the device may malfunction. Take care to prevent chattering noise from entering the device when the input level is fixed, and also in the transition period when the input level passes through the area between  $V_{IL}$  (Max.) and  $V_{IH}$  (Min.).

### 7. Prohibition of access to reserved addresses

Access to reserved addresses is prohibited. The reserved addresses are provided for possible future expansion of functions. Do not access these addresses as the correct operation of the LSI is not guaranteed.

### 8. Differences between products

Before changing from one product to another, for example to a product with a different part number, confirm that the change will not lead to problems. The characteristics of a microprocessing unit or microcontroller unit products in the same group but having a different part number might differ in terms of internal memory capacity, layout pattern, and other factors, which can affect the ranges of electrical characteristics, such as characteristic values, operating margins, immunity to noise, and amount of radiated noise. When changing to a product with a different part number, implement a system-evaluation test for the given product.

## Notice

1. Descriptions of circuits, software and other related information in this document are provided only to illustrate the operation of semiconductor products and application examples. You are fully responsible for the incorporation or any other use of the circuits, software, and information in the design of your product or system. Renesas Electronics disclaims any and all liability for any losses and damages incurred by you or third parties arising from the use of these circuits, software, or information.
2. Renesas Electronics hereby expressly disclaims any warranties against and liability for infringement or any other claims involving patents, copyrights, or other intellectual property rights of third parties, by or arising from the use of Renesas Electronics products or technical information described in this document, including but not limited to, the product data, drawings, charts, programs, algorithms, and application examples.
3. No license, express, implied or otherwise, is granted hereby under any patents, copyrights or other intellectual property rights of Renesas Electronics or others.
4. You shall not alter, modify, copy, or reverse engineer any Renesas Electronics product, whether in whole or in part. Renesas Electronics disclaims any and all liability for any losses or damages incurred by you or third parties arising from such alteration, modification, copying or reverse engineering.
5. Renesas Electronics products are classified according to the following two quality grades: "Standard" and "High Quality". The intended applications for each Renesas Electronics product depends on the product's quality grade, as indicated below.
  - "Standard": Computers; office equipment; communications equipment; test and measurement equipment; audio and visual equipment; home electronic appliances; machine tools; personal electronic equipment; industrial robots; etc.
  - "High Quality": Transportation equipment (automobiles, trains, ships, etc.); traffic control (traffic lights); large-scale communication equipment; key financial terminal systems; safety control equipment; etc.
- Unless expressly designated as a high reliability product or a product for harsh environments in a Renesas Electronics data sheet or other Renesas Electronics document, Renesas Electronics products are not intended or authorized for use in products or systems that may pose a direct threat to human life or bodily injury (artificial life support devices or systems; surgical implantations; etc.), or may cause serious property damage (space system; undersea repeaters; nuclear power control systems; aircraft control systems; key plant systems; military equipment; etc.). Renesas Electronics disclaims any and all liability for any damages or losses incurred by you or any third parties arising from the use of any Renesas Electronics product that is inconsistent with any Renesas Electronics data sheet, user's manual or other Renesas Electronics document.
6. When using Renesas Electronics products, refer to the latest product information (data sheets, user's manuals, application notes, "General Notes for Handling and Using Semiconductor Devices" in the reliability handbook, etc.), and ensure that usage conditions are within the ranges specified by Renesas Electronics with respect to maximum ratings, operating power supply voltage range, heat dissipation characteristics, installation, etc. Renesas Electronics disclaims any and all liability for any malfunctions, failure or accident arising out of the use of Renesas Electronics products outside of such specified ranges.
7. Although Renesas Electronics endeavors to improve the quality and reliability of Renesas Electronics products, semiconductor products have specific characteristics, such as the occurrence of failure at a certain rate and malfunctions under certain use conditions. Unless designated as a high reliability product or a product for harsh environments in a Renesas Electronics data sheet or other Renesas Electronics document, Renesas Electronics products are not subject to radiation resistance design. You are responsible for implementing safety measures to guard against the possibility of bodily injury, injury or damage caused by fire, and/or danger to the public in the event of a failure or malfunction of Renesas Electronics products, such as safety design for hardware and software, including but not limited to redundancy, fire control and malfunction prevention, appropriate treatment for aging degradation or any other appropriate measures. Because the evaluation of microcomputer software alone is very difficult and impractical, you are responsible for evaluating the safety of the final products or systems manufactured by you.
8. Please contact a Renesas Electronics sales office for details as to environmental matters such as the environmental compatibility of each Renesas Electronics product. You are responsible for carefully and sufficiently investigating applicable laws and regulations that regulate the inclusion or use of controlled substances, including without limitation, the EU RoHS Directive, and using Renesas Electronics products in compliance with all these applicable laws and regulations. Renesas Electronics disclaims any and all liability for damages or losses occurring as a result of your noncompliance with applicable laws and regulations.
9. Renesas Electronics products and technologies shall not be used for or incorporated into any products or systems whose manufacture, use, or sale is prohibited under any applicable domestic or foreign laws or regulations. You shall comply with any applicable export control laws and regulations promulgated and administered by the governments of any countries asserting jurisdiction over the parties or transactions.
10. It is the responsibility of the buyer or distributor of Renesas Electronics products, or any other party who distributes, disposes of, or otherwise sells or transfers the product to a third party, to notify such third party in advance of the contents and conditions set forth in this document.
11. This document shall not be reprinted, reproduced or duplicated in any form, in whole or in part, without prior written consent of Renesas Electronics.
12. Please contact a Renesas Electronics sales office if you have any questions regarding the information contained in this document or Renesas Electronics products.

(Note1) "Renesas Electronics" as used in this document means Renesas Electronics Corporation and also includes its directly or indirectly controlled subsidiaries.

(Note2) "Renesas Electronics product(s)" means any product developed or manufactured by or for Renesas Electronics.

(Rev.4.0-1 November 2017)

## Corporate Headquarters

TOYOSU FORESIA, 3-2-24 Toyosu,  
Koto-ku, Tokyo 135-0061, Japan  
[www.renesas.com](http://www.renesas.com)

## Trademarks

Renesas and the Renesas logo are trademarks of Renesas Electronics Corporation. All trademarks and registered trademarks are the property of their respective owners.

## Contact information

For further information on a product, technology, the most up-to-date version of a document, or your nearest sales office, please visit:  
[www.renesas.com/contact/](http://www.renesas.com/contact/).