

RL78/G23

Remote Control Signal Reception (RC-6 Format)

Introduction

This application note describes how to receive remote control signals using a timer array unit and external interrupts. If no remote control signal is detected for a predetermined time, this application shifts to STOP mode to reduce power consumption.

The applicable remote control format is RC-6 (including header and 16-bit data).

Target Device

RL78/G23

When applying the sample program covered in this application note to another microcomputer, modify the program according to the specifications for the target microcomputer and conduct an extensive evaluation of the modified program.

Contents

1. Specification	3
1.1 Overview of Specification	3
1.2 Details of Operation	4
2. Operation Confirmation Conditions	10
3. Hardware Descriptions	11
3.1 Example of Hardware Configuration	11
3.2 List of Pins to be Used	12
4. Software Explanation	13
4.1 Setting of Option Byte	13
4.2 List of Constants	13
4.3 List of Variables	15
4.4 List of Functions	15
4.5 Specification of Functions	16
4.6 Flowcharts	18
4.6.1 Main Processing	18
4.6.2 External Interrupt (INTP0) Processing	19
4.6.3 TAU0 Channel 0 Timer Interrupt	20
4.6.4 TAU0 Channel 1 Timer Interrupt	20
4.6.5 Chattering Detection	21
4.6.6 Pulse Width Acquisition	22
4.6.7 LED Lighting Control	22
5. Sample Code	23
6. Reference Documents	23
Revision History	24

1. Specification

1.1 Overview of Specification

In this application note, a timer array unit and external interrupts are used. LEDs are turned on according to the remote control code received by the remote control signal receiver (REMC). When no remote control signal input is detected for 10 seconds, the MCU shifts to STOP mode. When a remote control signal input is detected in STOP mode, the application restarts the remote control signal reception processing.

Table 1-1 lists peripheral functions to be used and their use. Figure 1-1 shows the overview of sample code operation.

Table 1-2 shows the relation between remote control signal input and LED ON/OFF state.

Table 1-1 Peripheral Function and Use

Peripheral Function	Use
External interrupt (INTP0)	Remote control signal reception
Channels 0 of timer array unit 0 (TAU0)	STOP mode transition decision timer
Channels 1 of timer array unit 0 (TAU0)	Remote control signal pulse width measurement timer
P03, P02, P43, P42, P77, P41, P31, P76	Output pins to LED1 to LED8

Figure 1-1 Overview of Operation

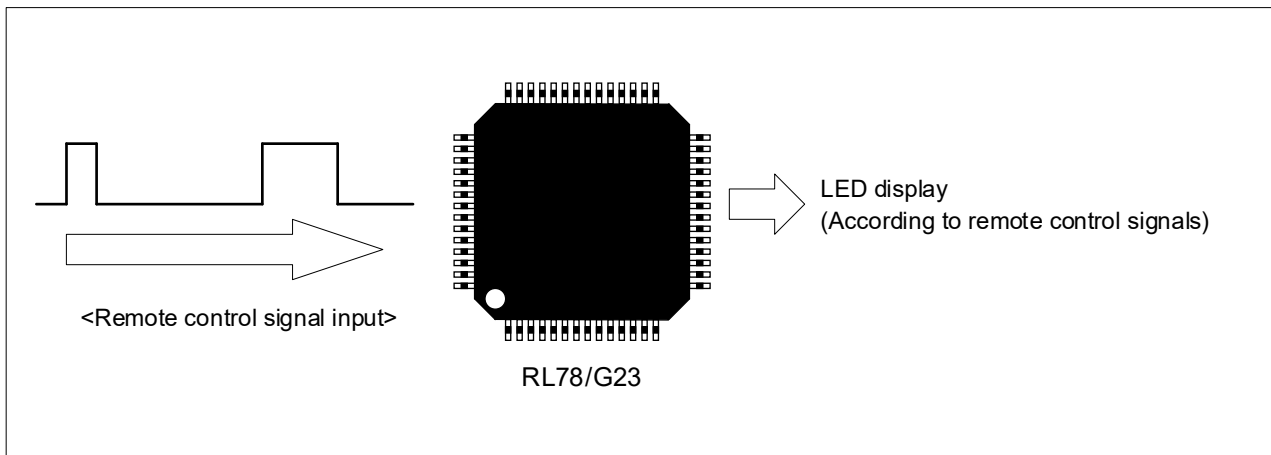

Table 1-2 Relation between Remote Control Signal Input and LED ON/OFF State

Remote Control Signal Input	LED1 to LED8 ON/OFF State
No input	Current state maintained
Channel 1 select	LED1 ON
Channel 2 select	LED2 ON
Channel 3 select	LED3 ON
Channel 4 select	LED4 ON
Channel 5 select	LED5 ON
Channel 6 select	LED6 ON
Channel 7 select	LED7 ON
Trailer bit data	0: LED8 OFF 1: LED8 ON
Other signal inputs	LED1 to LED7 OFF
No input (STOP mode)	All LEDs ON

1.2 Details of Operation

In this application note, RC-6 format remote control signals (including header and 16-bit data) are received using a timer array unit and external interrupts). When the application recognizes that the relevant channel button was pressed, it turns on the corresponding LED. Figure 1-2 shows the remote control signal (RC-6 format including header and 16-bit data) reception timing.

Figure 1-2 Remote Control Signal Reception Timing

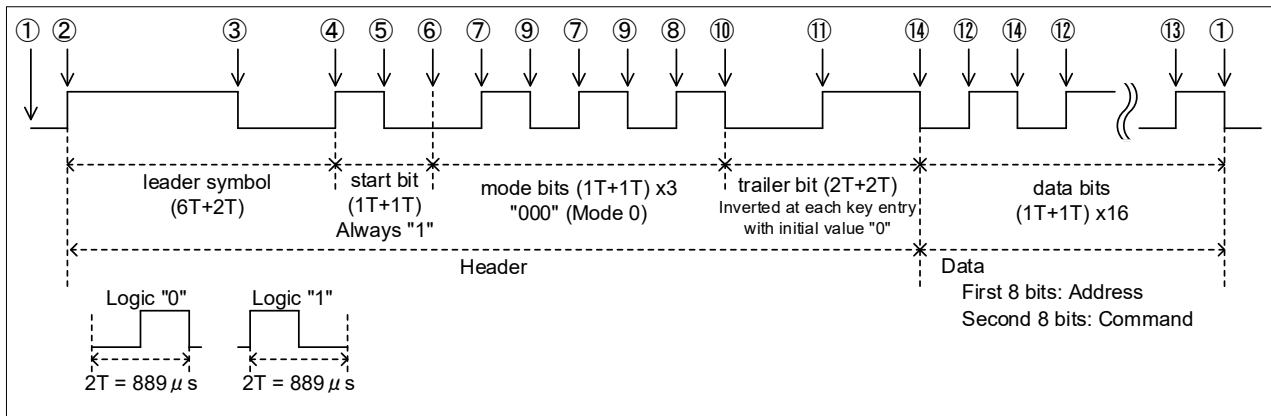

Table 1-3 lists the names of remote control signal reception timings ① to ⑭ in Figure 1-2.

Table 1-3 Names of Remote Control Signal Reception Timings

No.	Name	Description
①	IDLE	Signal wait processing state
②	START	Signal processing start
③	LEADER_HALF	1st half of leader symbol
④	LEADER_END	Leader symbol end
⑤	START BIT_HALF	1st half of start bit (bit data decision edge)
⑥	START BIT_END	Start bit end
⑦	MODE_HALF	1st half of 1st and 2nd mode bits (bit data decision edge)
⑧	MODE_LAST_HALF	1st half of 3rd mode bits
⑨	MODE_END	End of 1st and 2nd mode bits
⑩	MODE_LAST_END	End of 3rd mode bits
⑪	TRAIL_HALF	1st half of trailer bit (bit data decision edge)
⑫	DATA_HALF	1st half of 1st to 15th data bits (bit data decision edge)
⑬	DATA_LAST_HALF	1st half of 16th data bits (bit data decision edge)
⑭	DATA_END	End of data bits

Caution: These names are used in this sample code, but are not formal names in the RC-6 format.

Table 1-4 shows the correspondence between remote control input signals and remote control signal data. When the second byte (second-half 8 bits of data in Figure 1-2) of the received remote control signal data matches the signal data in Table 1-4, the application recognizes that the relevant channel button was pressed.

Table 1-4 Correspondence between Remote Control Input Signals and Signal Data

Remote Control Input Signal	Signal Data
Channel 1	0x01
Channel 2	0x02
Channel 3	0x03
Channel 4	0x04
Channel 5	0x05
Channel 6	0x06
Channel 7	0x07

When no remote control signal input is detected for 10 seconds, the MCU shifts to STOP mode. When a remote control signal is detected in STOP mode, the application release from STOP mode and restarts the remote control signal reception processing.

Figure 1-3 shows the transition (to STOP mode) timing. Figure 1-4 shows the state transition diagram.

Figure 1-3 Transition (to STOP Mode) Timing

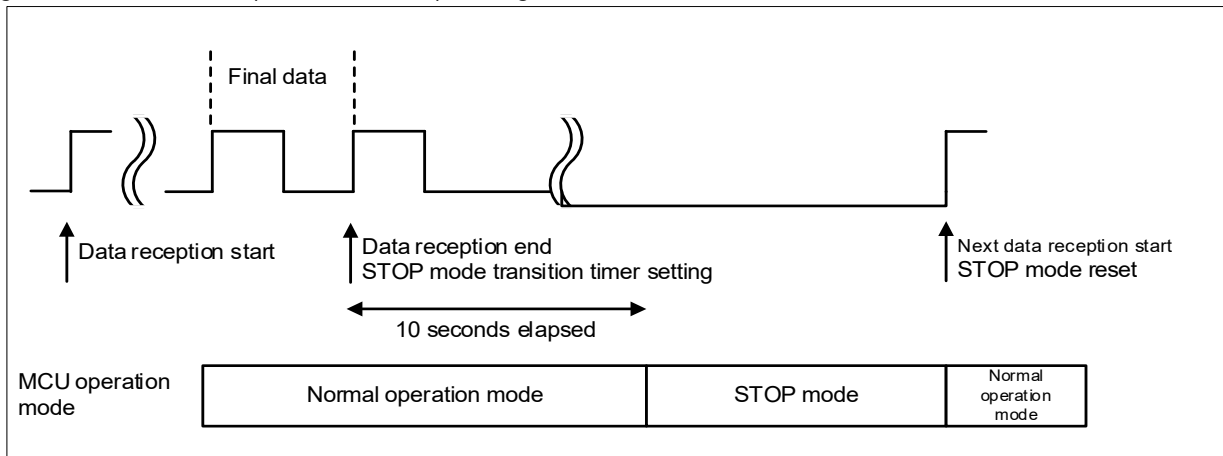
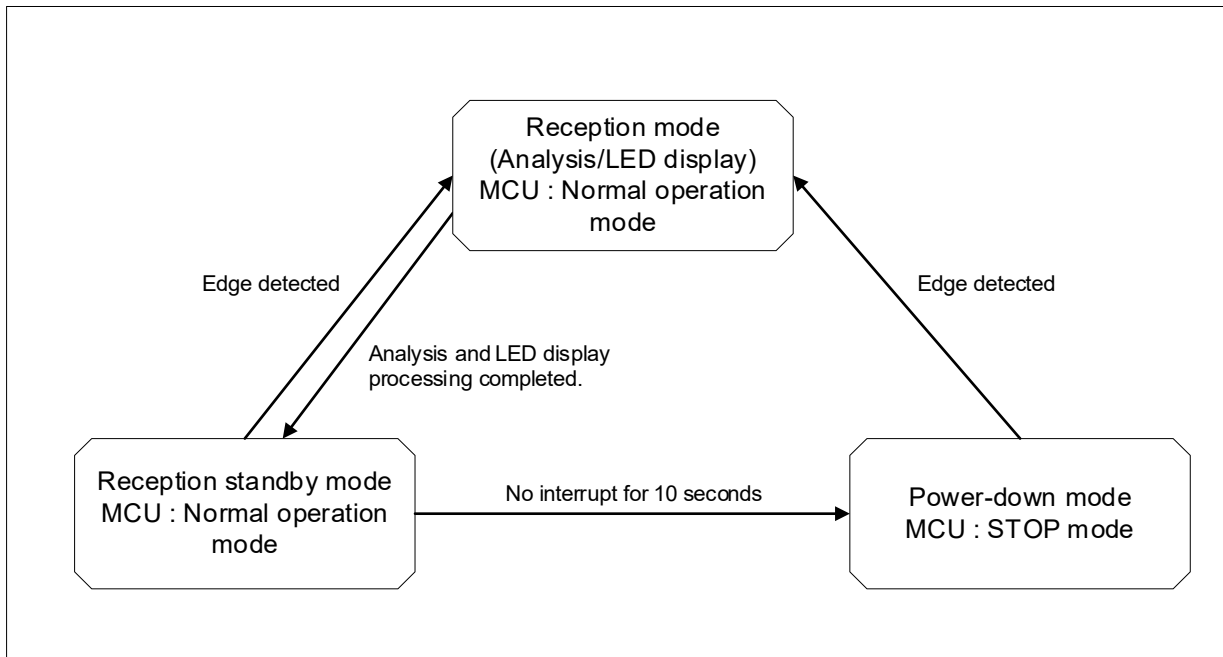

Figure 1-4 Remote Control Signal Reception State Transition Diagram



The following describes the main operation of this sample code.

(1) The application starts counting channel 0 of timer array unit 0 (TAU0). When the application detects the input remote control signal (INTP0), it performs the processing in step (2). If the INTP0 signal is not detected for 10 seconds, the application shifts to STOP mode. When the INTP0 signal is detected in STOP mode, the application performs the processing in step (2).

(2) The application stops counting channel 0 of TAU0 and performs the processing in step (3).

(3) The channel 1 of TAU0 measures the high level or low level width of the input signal.

When the measured high level or low level width falls within the normal range shown in Table 1-5, the application records the input signal level (P137: Low / High) and waits for the next INTP0 signal. (Repetition of step (3))

If the measured high level or low level width is out of the normal range, the application recognizes it as an error and quits the remote control signal reception processing. The processing returns to step (1).

However, if the INTP0 signal is not detected for 3.5 milliseconds, the application recognizes that the remote control signal has ended and performs the processing in step (4).

(4) The application performs LED lighting control, and then the processing returns to step (1).

Table 1-5 Normal Pulse Width and Stage Transitions

Previous Processing	Normal Range (1T = 444 μs)	Next Processing
① IDLE	(None)	② START
② START	6T	③ LEADER_HALF
③ LEADER_HALF	2T+1T	⑤ START_BIT_HALF
	2T	④ LEADER_END
④ LEADER_END	1T	⑤ START_BIT_HALF
⑤ START_BIT_HALF	1T+1T	⑦ MODE_HALF (Bit 1)
	1T	⑥ START_BIT_END
⑥ START_BIT_END	1T	⑦ MODE_HALF (Bit 1)
⑦ MODE_HALF (Bits 1 and 2)	2T	⑦ MODE_HALF (Bit (n+1))
	1T	⑨ MODE_END (Bit n)
⑧ MODE_LAST_HALF (Bit 3)	1T+2T	⑪ TRAIL_HALF
	1T	⑩ MODE_LAST_END (Bit 3)
⑨ MODE_END (Bits 1 and 2)	1T	⑦ MODE_HALF (Bit (n+1))
⑩ MODE_LAST_END (Bit 3)	2T	⑪ TRAIL_HALF
⑪ TRAIL_HALF	2T+1T	⑫ DATA_HALF (Bit 1)
	2T	⑭ DATA_END (Bit 0)
⑫ DATA_HALF (Bits 1 to 15)	1T+1T	⑫ DATA_HALF (Bit (n+1))
	1T	⑭ DATA_END (Bit n)
⑬ DATA_LAST_HALF (Bit 16)	1T	⑭ IDLE
⑭ DATA_END (Bit n)	1T	⑫ DATA_HALF (Bit (n+1))

Remark n: Current bit, n+1: Next bit

Table 1-6 shows the state transition matrix of this sample code.

Table 1-6 State Transition Matrix

Pulse Width (1T = 444 μ s) State	6T (2667 μ s)	3T (1333 μ s)	2T (889 μ s)	1T (444 μ s)	その他
①IDLE	START	START	START	START	START
②START	LEADER_HALF	ERROR	ERROR	ERROR	ERROR
③LEADER_HALF	ERROR	START_BIT_HALF	LEADER_END	ERROR	ERROR
④LEADER_END	ERROR	ERROR	ERROR	START_BIT_HALF	ERROR
⑤START_BIT_HALF	ERROR	ERROR	MODE_HALF (n=1)	START_BIT_END	ERROR
⑥START_BIT_END	ERROR	ERROR	ERROR	MODE_HALF (n=1)	ERROR
⑦MODE_HALF (n=1, 2)	ERROR	ERROR	MODE_HALF (n+1)	MODE_END	ERROR
⑧MODE_LAST_HALF (n=3)	ERROR	TRAIL_HALF	ERROR	MODE_LAST_END	ERROR
⑨MODE_END (n=1, 2)	ERROR	ERROR	ERROR	MODE_HALF (n+1)	ERROR
⑩MODE_LAST_END (n=3)	ERROR	ERROR	TRAIL_HALF	ERROR	ERROR
⑪TRAIL_HALF	ERROR	DATA_HALF (n=1)	DATA_END (n=0)	ERROR	ERROR
⑫DATA_HALF (n=1 to 15)	ERROR	ERROR	DATA_HALF (n+1)	DATA_END	ERROR
⑬DATA_LAST_HALF (n=16)	ERROR	ERROR	ERROR	IDLE	ERROR
⑭DATA_END	ERROR	ERROR	ERROR	DATA_HALF (n+1)	ERROR

The following describes the main settings for peripheral functions.

- (1) External interrupt (INTP0)
 - Set both rising and falling edges to the valid edge for INTP0.
 - Enable INTP0 interrupts (interrupt priority level 3).

- (2) Timer array unit 0 (TAU0) channel 0 (for deciding transition to STOP mode)
 - Set the timer operation mode to interval timer mode.
 - Operating clock: CK01, clock source: fCLK/2¹⁵
 - Interval time period: 10,000 ms (10 seconds)
 - Disable interrupts at count start.
 - Enable INTTM00 interrupts (interrupt priority level 3).

- (3) Timer array unit 0 (TAU0) channel 1 (for measuring signal pulse width)
 - Set the timer operation mode to interval timer mode.
 - Operating clock: CK00, clock source: fCLK/2⁵
 - Interval time period: 3,500 μ s
 - Disable interrupts at count start.
 - Enable INTTM01 interrupts (interrupt priority level 2).

- (4) I/O ports
 - P03, P02, P43, P42, P77, P41, P31 and P76 pins: Set as output ports.

2. Operation Confirmation Conditions

The operation of the sample code provided with this application note has been tested under the following conditions.

Table 2-1 Operation Confirmation Conditions

Item	Description
MCU used	RL78/G23 (R7F100GLG)
Board used	RL78/G23-64p Fast Prototyping Board (RTK7RLG230CLG000BJ)
Operating frequency	<ul style="list-style-type: none"> ▪ High-speed on-chip oscillator clock (f_{IH}): 32 MHz ▪ Low-speed on-chip oscillator clock (f_{IL}): 32.768 kHz
Operating voltage	5.0 V (can be operated at 1.8 V to 5.5 V) LVD0 operations (V_{LVD0}): Reset mode At rising edge TYP. 1.875 V At falling edge TYP. 1.835 V
Integrated development environment (CS+)	CS+ for CC E8.05.00 from Renesas Electronics Corp.
C compiler (CS+)	CC-RL V1.10.00 from Renesas Electronics Corp.
Integrated development environment (e2studio)	e2studio V2021-04 (21.4.0) from Renesas Electronics Corp.
C compiler (e2studio)	CC-RL V1.10.00 from Renesas Electronics Corp.
Integrated development environment (IAR)	IAR Embedded Workbench for Renesas RL78 V4.21.1 from IAR Systems Corp.
C compiler (IAR)	IAR C/C++ Compiler for Renesas RL78 V4.21.1.2260 from IAR Systems Corp.
Smart configurator (SC)	V1.0.1 from Renesas Electronics Corp.
Board support package (BSP)	V1.00 from Renesas Electronics Corp.
Remote controller used	ATV-102 supplied by Asahi Electrochemical Co., Ltd. (Philips DVD ⑧①⑨)

3. Hardware Descriptions

3.1 Example of Hardware Configuration

Figure 3-1 shows an example of the hardware configuration used in the application note.

Figure 3-1 Hardware Configuration

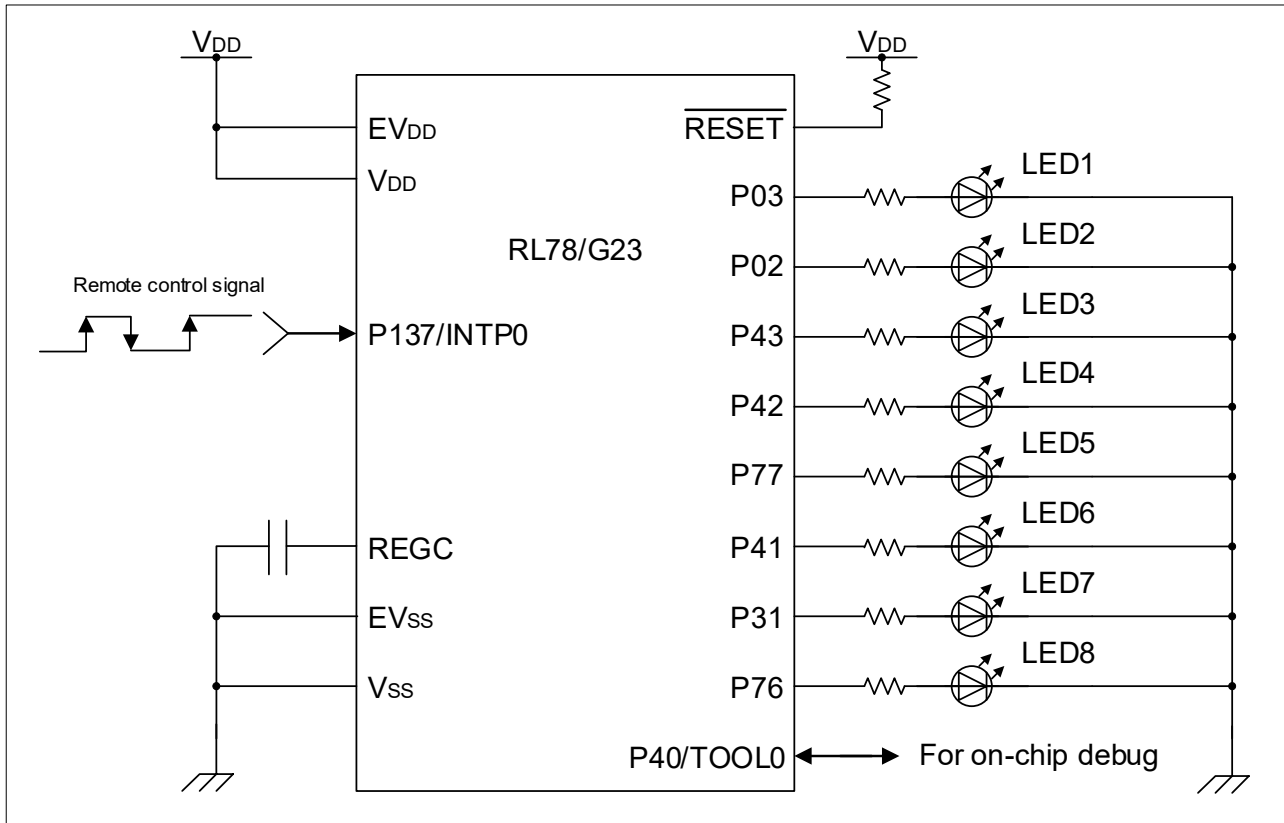

- Note 1. This schematic circuit diagram is simplified to show the outline of connections. When creating actual circuits, design them using appropriate pin processing so that the circuits meet electrical characteristics. (Connect input-only ports to V_{DD} or V_{SS} individually through a resistor.)
- Note 2. Connect pins (with a name beginning with EV_{SS}), if any, to V_{SS}, and connect pins (with a name beginning with EV_{DD}), if any, to V_{DD}.
- Note 3. Set V_{DD} to a voltage not less than the reset release voltage (V_{LVD0}) set by the LVD0.

3.2 List of Pins to be Used

Table 3-1 lists the pins to be used and their functions.

Table 3-1 Pins to be Used and Their Functions

Pin name	I/O	Functions
P137/INTP0	Input	Remote control signal input
P03	Output	LED (LED1) control port
P02	Output	LED (LED2) control port
P43	Output	LED (LED3) control port
P42	Output	LED (LED4) control port
P77	Output	LED (LED5) control port
P41	Output	LED (LED6) control port
P31	Output	LED (LED7) control port
P76	Output	LED (LED8) control port

Caution In this application note, only the used pins are processed. When actually designing your circuit, make sure the design includes sufficient pin processing and meets electrical characteristic requirements.

4. Software Explanation

4.1 Setting of Option Byte

Table 4-1 shows the option byte settings.

Table 4-1 Option Byte Settings

Address	Setting Value	Contents
000C0H / 040C0H	11101110B	Disables the watchdog timer. (Counting stopped after reset)
000C1H / 040C1H	11111110B	LVD0 detection voltage: reset mode At rising edge TYP. 1.875 V At falling edge TYP. 1.835 V
000C2H / 040C2H	11101000B	HS mode, High-speed on-chip oscillator clock (f_{IH}): 32 MHz
000C3H / 040C3H	10000100B	Enables on-chip debugging

4.2 List of Constants

Table 4-2 and Table 4-3 list the constants that are used in the sample code.

Table 4-2 Constant (1/2)

Constant Name	Setting Value	Description
RC6_ADDRESS_CUSTOM	0x04	Address specific to remote controller to be used
R_WAIT_CHATTERING	120U	Number of wait loops for chattering detection
RC6_6T_MAX	3196U	Maximum time for decision as pulse width 6T
RC6_6T_MIN	2131U	Minimum time for decision as pulse width 6T
RC6_3T_MAX	1598U	Maximum time for decision as pulse width 3T
RC6_3T_MIN	1065U	Minimum time for decision as pulse width 3T
RC6_2T_MAX	1064U	Maximum time for decision as pulse width 2T
RC6_2T_MIN	710U	Minimum time for decision as pulse width 2T
RC6_1T_MAX	540U	Maximum time for decision as pulse width 1T
RC6_1T_MIN	330U	Minimum time for decision as pulse width 1T
RC6_MODE_0	0x00	Mode bit value indicating mode 0
RC6_MODE_BITS	3U	Number of mode bits
RC6_DATA_BITS	8U+8U	Number of data bits
R_LOGIC_HIGH	1	Logic "1"
R_LOGIC_LOW	0	Logic "0"
R_BUFFER_TYPE_START	0	Receive buffer type (Reception start)
R_BUFFER_TYPE_MODE	1	Receive buffer type (Mode bits)
R_BUFFER_TYPE_TRAIL	2	Receive buffer type (Trailer bit)
R_BUFFER_TYPE_DATA	3	Receive buffer type (Data bits)
R_BUFFER_TYPE_NUM	4	Number of receive buffer types
R_PROCESS_STATE_WAIT	0	Processing state (Waiting for receive data)
R_PROCESS_STATE_FINISHED	1	Processing state (Reception complete)
R_PROCESS_STATE_TIMEOUT	2	Processing state (Time out)
R_PROCESS_STATE_ERROR	3	Processing state (Error)

Table 4-3 Constant (2/2)

Constant Name	Setting Value	Description
RC6_STAGE_IDLE	0	Processing in progress (Waiting for receive data)
RC6_STAGE_START	1	Processing in progress (Reception start)
RC6_STAGE_LEADER_HALF	3	Processing in progress (Leader symbol center)
RC6_STAGE_LEADER_END	4	Processing in progress (Leader symbol end)
RC6_STAGE_START_BIT_HALF	5	Processing in progress (Start bit center)
RC6_STAGE_START_BIT_END	6	Processing in progress (Start bit end)
RC6_STAGE_MODE_HALF	7	Processing in progress (Mode bit center)
RC6_STAGE_MODE_END	8	Processing in progress (Mode bit end)
RC6_STAGE_MODE_LAST_HALF	9	Processing in progress (Mode bit 3 center)
RC6_STAGE_MODE_LAST_END	10	Processing in progress (Mode bit 3 end)
RC6_STAGE_TRAIL_HALF	11	Processing in progress (Trailer bit center)
RC6_STAGE_DATA_HALF	12	Processing in progress (Data bit center)
RC6_STAGE_DATA_END	13	Processing in progress (Data bit end)
RC6_STAGE_DATA_LAST_HALF	14	Processing in progress (Data bit 16 center)
RC6_STAGE_ERROR	15	Processing in progress (Error)
RC6_STAGE_NUM	16	Number of pulse types during processing
RC6_PULSE_TYPE_OTHERWISE	0	Pulse type (Out of normal range)
RC6_PULSE_TYPE_6T	1	Pulse type (6T)
RC6_PULSE_TYPE_3T	2	Pulse type (3T)
RC6_PULSE_TYPE_2T	3	Pulse type (2T)
RC6_PULSE_TYPE_1T	4	Pulse type (1T)
RC6_PULSE_TYPE_NUM	5	Number of pulse types
RC6_COMMAND_ALL_OFF	0x00	All LEDs OFF
RC6_COMMAND_CODE_01	0x01	Channel 1 data (RC-6 format)
RC6_COMMAND_CODE_02	0x02	Channel 2 data (RC-6 format)
RC6_COMMAND_CODE_03	0x03	Channel 3 data (RC-6 format)
RC6_COMMAND_CODE_04	0x04	Channel 4 data (RC-6 format)
RC6_COMMAND_CODE_05	0x05	Channel 5 data (RC-6 format)
RC6_COMMAND_CODE_06	0x06	Channel 6 data (RC-6 format)
RC6_COMMAND_CODE_07	0x07	Channel 7 data (RC-6 format)

4.3 List of Variables

Table 4-4 lists global variables.

Table 4-4 Global Variables

Type	Variable Name	Description	Function Used
r_process_state_t	g_process_state	Current processing state	main, r_Config_INTC_intp0_interrupt, r_Config_TAU_0_0_interrupt, r_Config_TAU_0_1_interrupt
rc6_stage_t	g_stage	Remote control signal reception timing during processing	main, r_Config_INTC_intp0_interrupt
uint16_t	g_receive_buffer[R_BUFFER_TYPE_NUM+1]	Receive buffer	main, r_Config_INTC_intp0_interrupt
uint8_t	G_receive_buffer_bits[R_BUFFER_TYPE_NUM+1]	Maximum number of receive buffers	main, r_Config_INTC_intp0_interrupt
uint8_t	g_bit_num	Currently processed bit position of mode bits and data bits	r_Config_INTC_intp0_interrupt
uint16_t *	gp_buffer	Address of currently processed receive buffer	r_Config_INTC_intp0_interrupt
uint8_t *	gp_max_bits	Maximum number of currently processed receive buffers	r_Config_INTC_intp0_interrupt
rc6_stage_t	g_trans_table[RC6_STAGE_NUM][RC6_PULSE_TYPE_NUM]	Receive data transition table	r_Config_INTC_intp0_interrupt

4.4 List of Functions

Table 4-5 shows a list of functions.

Table 4-5 Functions

Function Name	Outline
r_Config_INTC_intp0_interrupt	External interrupt (INTP0) processing
r_Config_TAU0_0_interrupt	TAU0 channel 0 timer interrupt
r_Config_TAU0_1_interrupt	TAU0 channel 1 timer interrupt
detect_chattering	Chattering detection
R_TAU0_1_get_pulse_timer	Pulse width acquisition
r_port_set_LED	LED lighting control

4.5 Specification of Functions

The function specifications of the sample code are shown below.

r_Config_INTC_intp0_interrupt	
Outline	External interrupt (INTP0) processing
Header	Config_INTC.h
Declaration	static void __near r_Config_INTC_intp0_interrupt (void)
Description	Performs remote control signal reception processing when an INTP0 interrupt is generated.
Argument	None
Return Value	None
r_Config_TAU0_0_interrupt	
Outline	TAU0 channel 0 timer interrupt
Header	Config_TAU0_0.h
Declaration	static void __near r_Config_TAU0_0_interrupt(void)
Description	Informs main that no remote control signal was detected for 10 seconds. (Transition to STOP mode)
Argument	None
Return Value	None
r_Config_TAU0_1_interrupt	
Outline	TAU0 channel 1 timer interrupt
Header	Config_TAU0_1.h
Declaration	static void __near r_Config_TAU0_1_interrupt(void)
Description	Informs main that no remote control signal was detected for 3.5 milliseconds. (Remote control signal reception complete)
Argument	None
Return Value	None
detect_chattering	
Outline	Chattering detection
Header	Config_INTC_user.c
Declaration	static uint8_t detect_chattering(void)
Description	Checks whether chattering is present when an INTP0 interrupt is generated.
Argument	None
Return Value	1: Chattering occurred 0: No chattering present
r_TAU0_1_get_pulse_timer	
Outline	Pulse width acquisition
Header	Config_TAU0_1_user.c
Declaration	static uint16_t r_TAU0_1_get_pulse_timer(void)
Description	Acquires pulse width using INTP0 interrupts.
Argument	None
Return Value	Pulse width

r_port_set_LED	
Outline	LED lighting control
Header	Config_PORT.h
Declaration	void r_port_set_LED(uint8_t num, uint8_t is_LED8_on)
Description	Turns on the LED specified by argument "num". When "num" = 0, all LEDs are turned off. Also controls LED8 ON/OFF according to "is_LED8_on".
Argument	uint8_t num: Number of LED (1 to 7) to be turned on When "uint8_t is_LED8_on" = 1, LED8 is turned on. When "uint8_t is_LED8_on" = 0, LED8 is turned off.
Return Value	None

4.6 Flowcharts

4.6.1 Main Processing

Figure 4-1 shows the flowchart of the main processing.

Figure 4-1 Main Processing

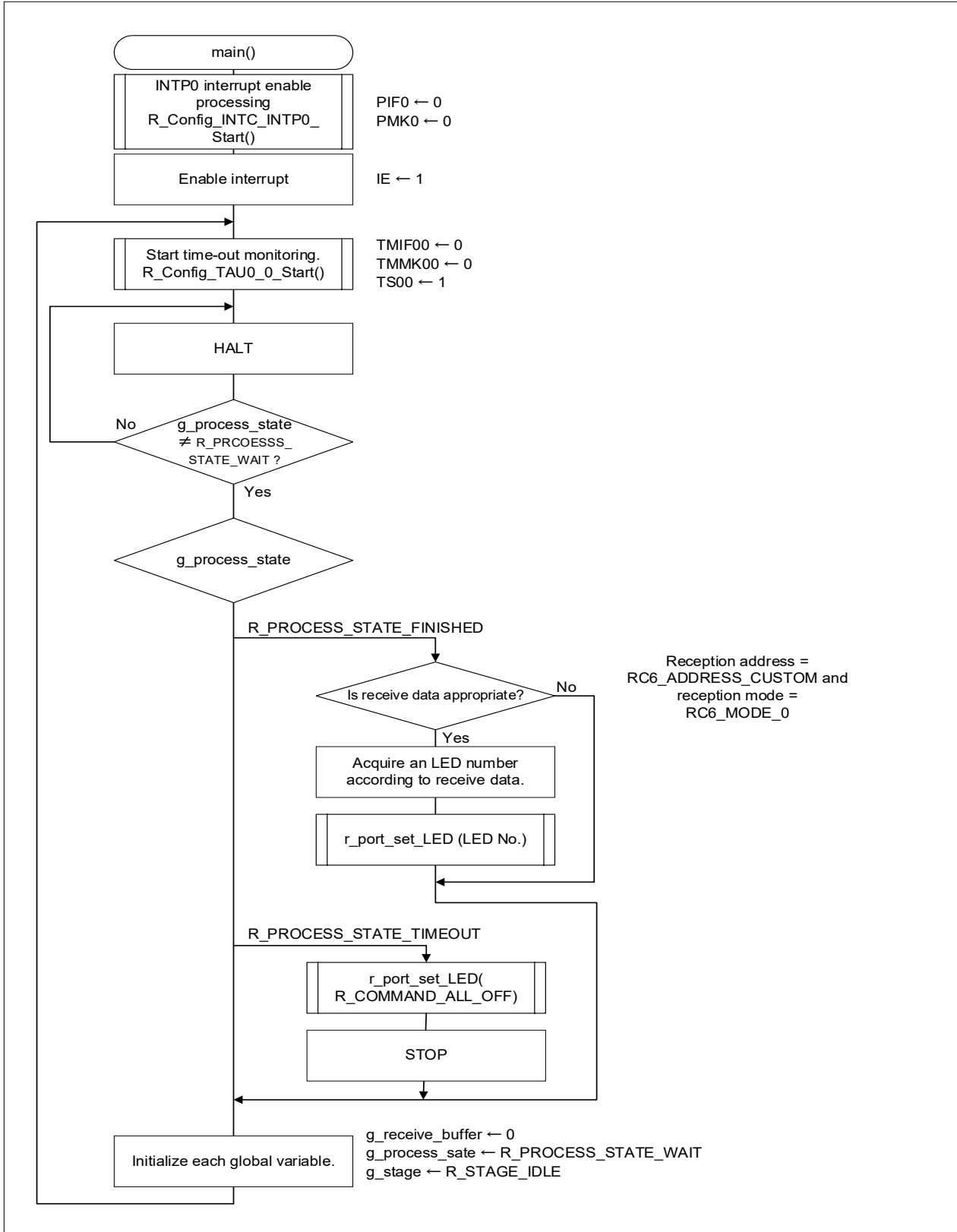

4.6.2 External Interrupt (INTP0) Processing

Figure 4-2 shows the flowchart of the external interrupt (INTP0) processing.

Figure 4-2 External Interrupt (INTP0) Processing

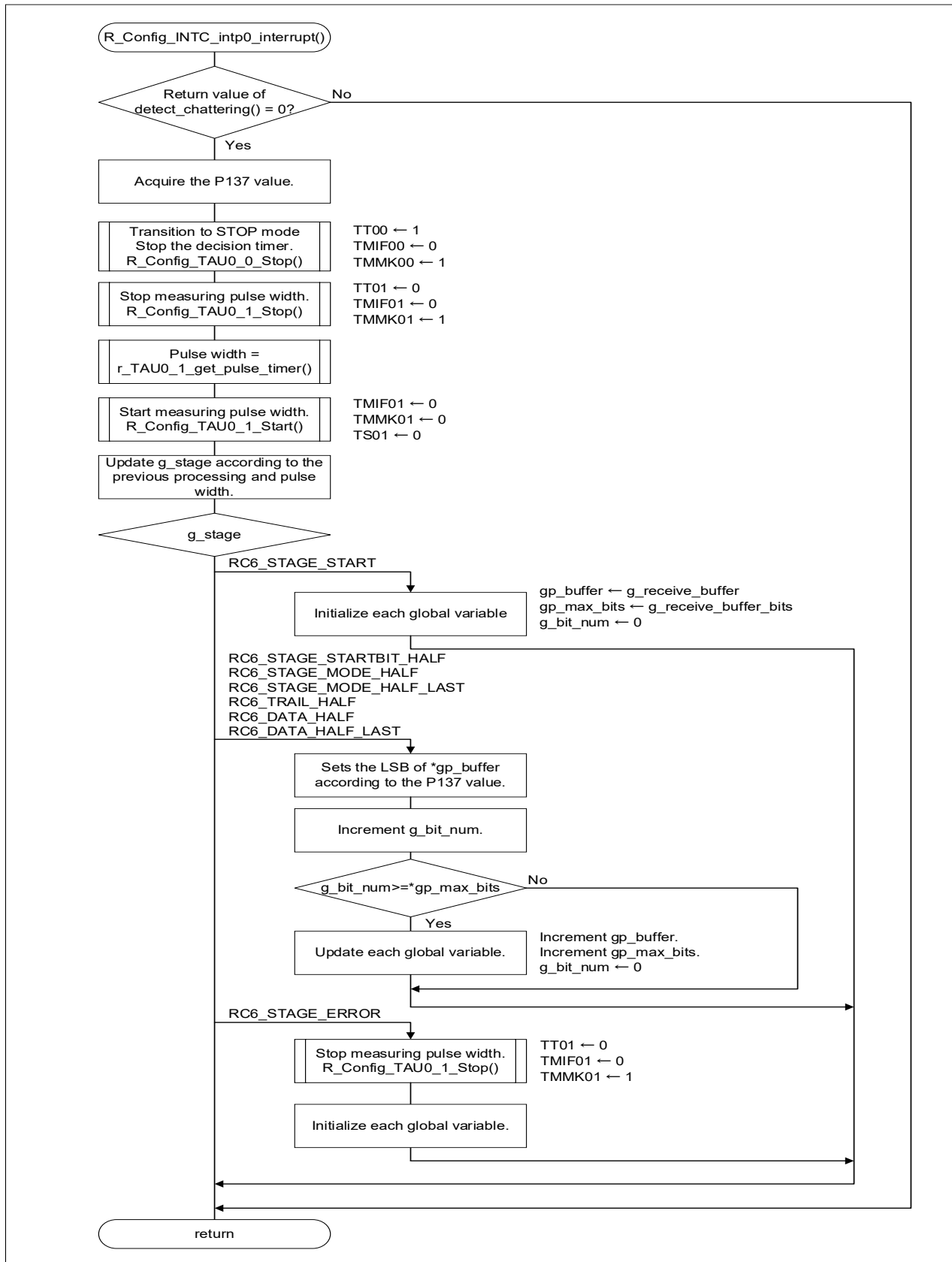

4.6.3 TAU0 Channel 0 Timer Interrupt

Figure 4-3 shows the flowchart of TAU0 channel 0 timer interrupt.

Figure 4-3 TAU0 Channel 0 Timer Interrupt

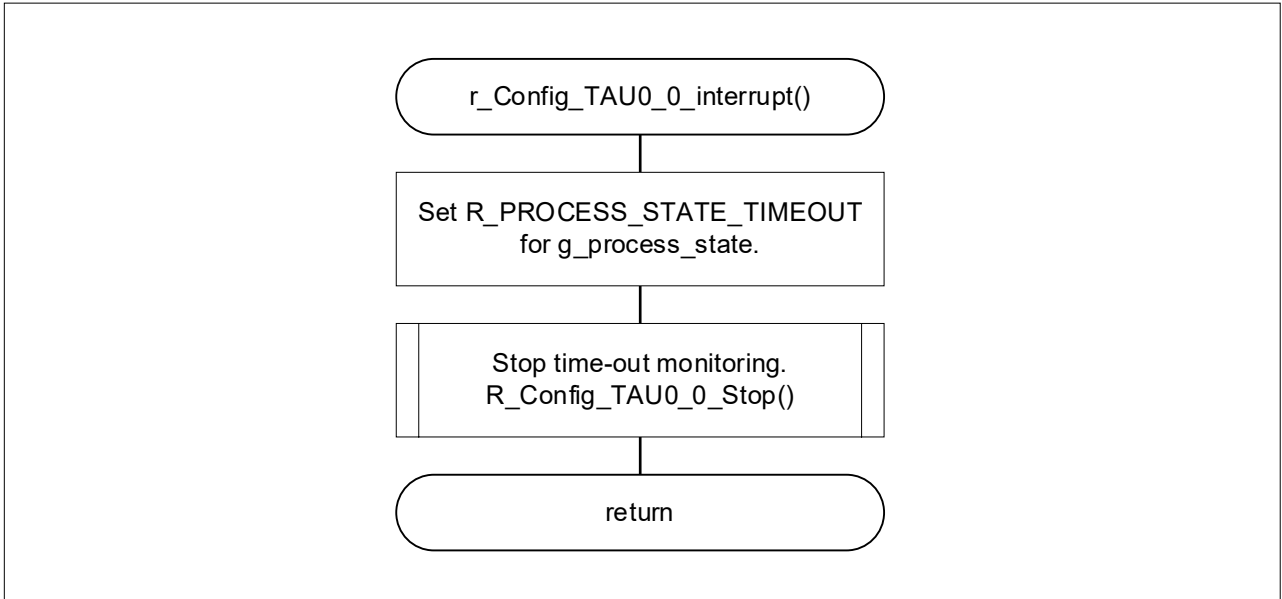

4.6.4 TAU0 Channel 1 Timer Interrupt

Figure 4-4 shows the flowchart of TAU0 channel 1 timer interrupt.

Figure 4-4 TAU0 Channel 1 Timer Interrupt

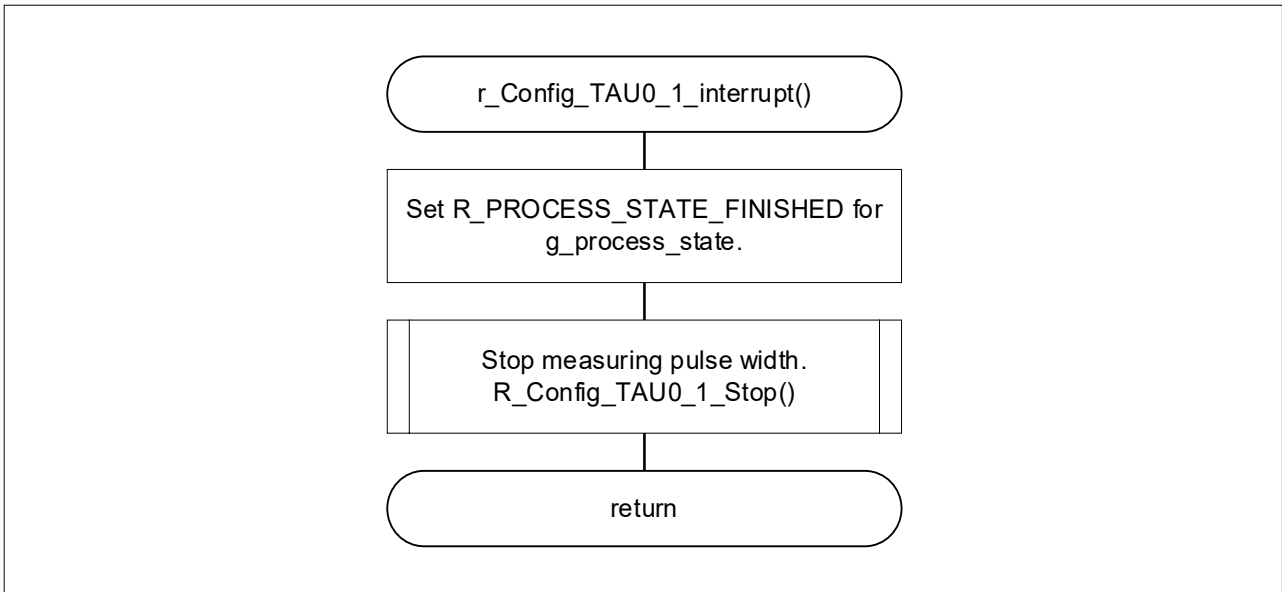

4.6.5 Chattering Detection

Figure 4-5 shows the flowchart for detecting chattering.

Figure 4-5 Chattering Detection

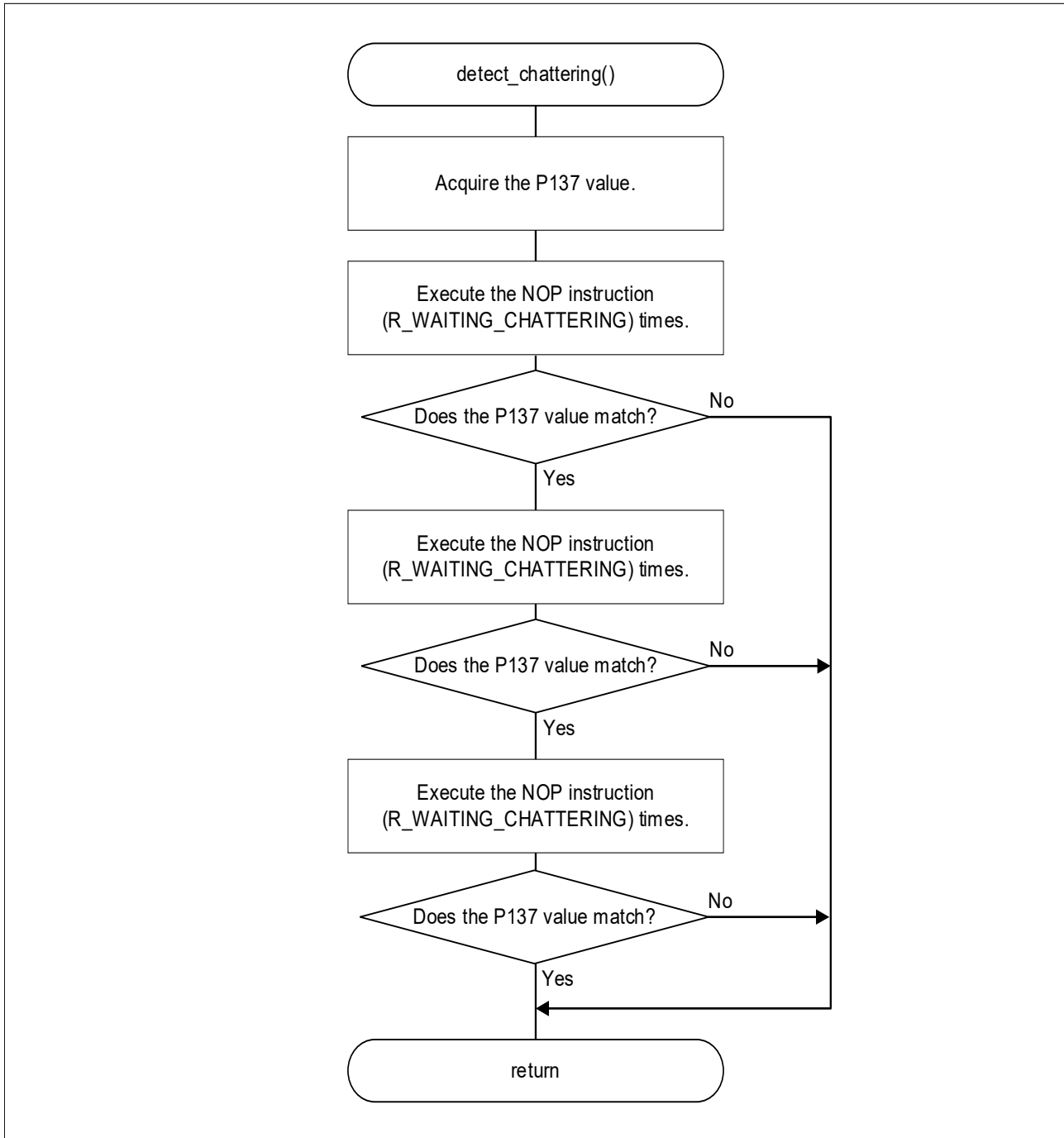

4.6.6 Pulse Width Acquisition

Figure 4-6 shows the flowchart for acquiring pulse width.

Figure 4-6 Pulse Width Acquisition

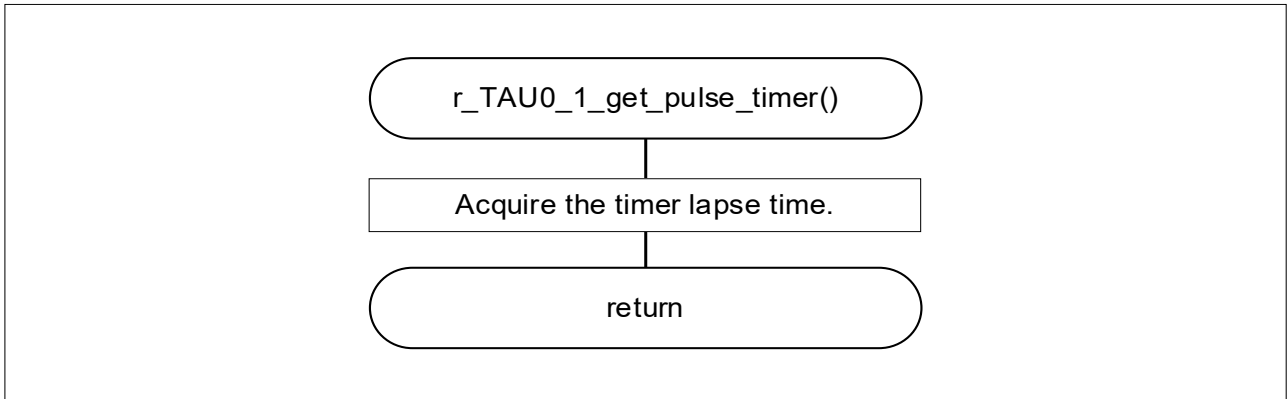

4.6.7 LED Lighting Control

Figure 4-7 shows the flowchart for LED lighting control.

Figure 4-7 LED Lighting Control

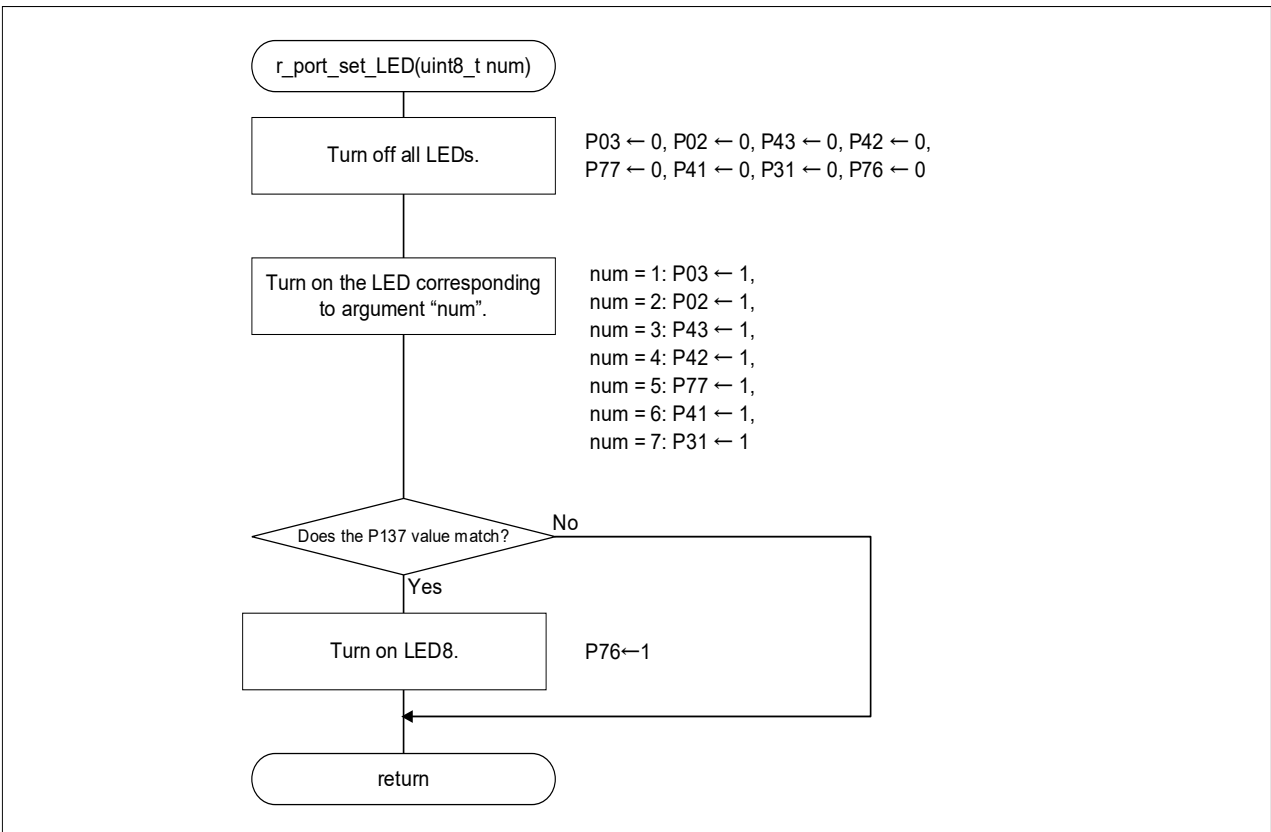

5. Sample Code

Sample code can be downloaded from the Renesas Electronics website.

6. Reference Documents

RL78/G23 User's Manual: Hardware (R01UH0896)

RL78 family user's manual software (R01US0015)

The latest versions can be downloaded from the Renesas Electronics website.

Technical update

The latest versions can be downloaded from the Renesas Electronics website.

All trademarks and registered trademarks are the property of their respective owners.

Revision History

Rev.	Date	Description	
		Page	Page
1.00	2021.04.13	—	First Edition
1.01	2021.07.12	8	Updated the Operation Confirmation Conditions

General Precautions in the Handling of Microprocessing Unit and Microcontroller Unit Products

The following usage notes are applicable to all Microprocessing unit and Microcontroller unit products from Renesas. For detailed usage notes on the products covered by this document, refer to the relevant sections of the document as well as any technical updates that have been issued for the products.

1. Precaution against Electrostatic Discharge (ESD)

A strong electrical field, when exposed to a CMOS device, can cause destruction of the gate oxide and ultimately degrade the device operation. Steps must be taken to stop the generation of static electricity as much as possible, and quickly dissipate it when it occurs. Environmental control must be adequate. When it is dry, a humidifier should be used. This is recommended to avoid using insulators that can easily build up static electricity.

Semiconductor devices must be stored and transported in an anti-static container, static shielding bag or conductive material. All test and measurement tools including work benches and floors must be grounded. The operator must also be grounded using a wrist strap. Semiconductor devices must not be touched with bare hands. Similar precautions must be taken for printed circuit boards with mounted semiconductor devices.

2. Processing at power-on

The state of the product is undefined at the time when power is supplied. The states of internal circuits in the LSI are indeterminate and the states of register settings and pins are undefined at the time when power is supplied. In a finished product where the reset signal is applied to the external reset pin, the states of pins are not guaranteed from the time when power is supplied until the reset process is completed. In a similar way, the states of pins in a product that is reset by an on-chip power-on reset function are not guaranteed from the time when power is supplied until the power reaches the level at which resetting is specified.

3. Input of signal during power-off state

Do not input signals or an I/O pull-up power supply while the device is powered off. The current injection that results from input of such a signal or I/O pull-up power supply may cause malfunction and the abnormal current that passes in the device at this time may cause degradation of internal elements. Follow the guideline for input signal during power-off state as described in your product documentation.

4. Handling of unused pins

Handle unused pins in accordance with the directions given under handling of unused pins in the manual. The input pins of CMOS products are generally in the high-impedance state. In operation with an unused pin in the open-circuit state, extra electromagnetic noise is induced in the vicinity of the LSI, an associated shoot-through current flows internally, and malfunctions occur due to the false recognition of the pin state as an input signal become possible.

5. Clock signals

After applying a reset, only release the reset line after the operating clock signal becomes stable. When switching the clock signal during program execution, wait until the target clock signal is stabilized. When the clock signal is generated with an external resonator or from an external oscillator during a reset, ensure that the reset line is only released after full stabilization of the clock signal. Additionally, when switching to a clock signal produced with an external resonator or by an external oscillator while program execution is in progress, wait until the target clock signal is stable.

6. Voltage application waveform at input pin

Waveform distortion due to input noise or a reflected wave may cause malfunction. If the input of the CMOS device stays in the area between V_{IL} (Max.) and V_{IH} (Min.) due to noise, for example, the device may malfunction. Take care to prevent chattering noise from entering the device when the input level is fixed, and also in the transition period when the input level passes through the area between V_{IL} (Max.) and V_{IH} (Min.).

7. Prohibition of access to reserved addresses

Access to reserved addresses is prohibited. The reserved addresses are provided for possible future expansion of functions. Do not access these addresses as the correct operation of the LSI is not guaranteed.

8. Differences between products

Before changing from one product to another, for example to a product with a different part number, confirm that the change will not lead to problems. The characteristics of a microprocessing unit or microcontroller unit products in the same group but having a different part number might differ in terms of internal memory capacity, layout pattern, and other factors, which can affect the ranges of electrical characteristics, such as characteristic values, operating margins, immunity to noise, and amount of radiated noise. When changing to a product with a different part number, implement a system-evaluation test for the given product.

Notice

1. Descriptions of circuits, software and other related information in this document are provided only to illustrate the operation of semiconductor products and application examples. You are fully responsible for the incorporation or any other use of the circuits, software, and information in the design of your product or system. Renesas Electronics disclaims any and all liability for any losses and damages incurred by you or third parties arising from the use of these circuits, software, or information.
2. Renesas Electronics hereby expressly disclaims any warranties against and liability for infringement or any other claims involving patents, copyrights, or other intellectual property rights of third parties, by or arising from the use of Renesas Electronics products or technical information described in this document, including but not limited to, the product data, drawings, charts, programs, algorithms, and application examples.
3. No license, express, implied or otherwise, is granted hereby under any patents, copyrights or other intellectual property rights of Renesas Electronics or others.
4. You shall be responsible for determining what licenses are required from any third parties, and obtaining such licenses for the lawful import, export, manufacture, sales, utilization, distribution or other disposal of any products incorporating Renesas Electronics products, if required.
5. You shall not alter, modify, copy, or reverse engineer any Renesas Electronics product, whether in whole or in part. Renesas Electronics disclaims any and all liability for any losses or damages incurred by you or third parties arising from such alteration, modification, copying or reverse engineering.
6. Renesas Electronics products are classified according to the following two quality grades: "Standard" and "High Quality". The intended applications for each Renesas Electronics product depends on the product's quality grade, as indicated below.

"Standard": Computers; office equipment; communications equipment; test and measurement equipment; audio and visual equipment; home electronic appliances; machine tools; personal electronic equipment; industrial robots; etc.

"High Quality": Transportation equipment (automobiles, trains, ships, etc.); traffic control (traffic lights); large-scale communication equipment; key financial terminal systems; safety control equipment; etc.

Unless expressly designated as a high reliability product or a product for harsh environments in a Renesas Electronics data sheet or other Renesas Electronics document, Renesas Electronics products are not intended or authorized for use in products or systems that may pose a direct threat to human life or bodily injury (artificial life support devices or systems; surgical implantations; etc.), or may cause serious property damage (space system; undersea repeaters; nuclear power control systems; aircraft control systems; key plant systems; military equipment; etc.). Renesas Electronics disclaims any and all liability for any damages or losses incurred by you or any third parties arising from the use of any Renesas Electronics product that is inconsistent with any Renesas Electronics data sheet, user's manual or other Renesas Electronics document.
7. No semiconductor product is absolutely secure. Notwithstanding any security measures or features that may be implemented in Renesas Electronics hardware or software products, Renesas Electronics shall have absolutely no liability arising out of any vulnerability or security breach, including but not limited to any unauthorized access to or use of a Renesas Electronics product or a system that uses a Renesas Electronics product. RENESAS ELECTRONICS DOES NOT WARRANT OR GUARANTEE THAT RENESAS ELECTRONICS PRODUCTS, OR ANY SYSTEMS CREATED USING RENESAS ELECTRONICS PRODUCTS WILL BE INVULNERABLE OR FREE FROM CORRUPTION, ATTACK, VIRUSES, INTERFERENCE, HACKING, DATA LOSS OR THEFT, OR OTHER SECURITY INTRUSION ("Vulnerability Issues"). RENESAS ELECTRONICS DISCLAIMS ANY AND ALL RESPONSIBILITY OR LIABILITY ARISING FROM OR RELATED TO ANY VULNERABILITY ISSUES. FURTHERMORE, TO THE EXTENT PERMITTED BY APPLICABLE LAW, RENESAS ELECTRONICS DISCLAIMS ANY AND ALL WARRANTIES, EXPRESS OR IMPLIED, WITH RESPECT TO THIS DOCUMENT AND ANY RELATED OR ACCOMPANYING SOFTWARE OR HARDWARE, INCLUDING BUT NOT LIMITED TO THE IMPLIED WARRANTIES OF MERCHANTABILITY, OR FITNESS FOR A PARTICULAR PURPOSE.
8. When using Renesas Electronics products, refer to the latest product information (data sheets, user's manuals, application notes, "General Notes for Handling and Using Semiconductor Devices" in the reliability handbook, etc.), and ensure that usage conditions are within the ranges specified by Renesas Electronics with respect to maximum ratings, operating power supply voltage range, heat dissipation characteristics, installation, etc. Renesas Electronics disclaims any and all liability for any malfunctions, failure or accident arising out of the use of Renesas Electronics products outside of such specified ranges.
9. Although Renesas Electronics endeavors to improve the quality and reliability of Renesas Electronics products, semiconductor products have specific characteristics, such as the occurrence of failure at a certain rate and malfunctions under certain use conditions. Unless designated as a high reliability product or a product for harsh environments in a Renesas Electronics data sheet or other Renesas Electronics document, Renesas Electronics products are not subject to radiation resistance design. You are responsible for implementing safety measures to guard against the possibility of bodily injury, injury or damage caused by fire, and/or danger to the public in the event of a failure or malfunction of Renesas Electronics products, such as safety design for hardware and software, including but not limited to redundancy, fire control and malfunction prevention, appropriate treatment for aging degradation or any other appropriate measures. Because the evaluation of microcomputer software alone is very difficult and impractical, you are responsible for evaluating the safety of the final products or systems manufactured by you.
10. Please contact a Renesas Electronics sales office for details as to environmental matters such as the environmental compatibility of each Renesas Electronics product. You are responsible for carefully and sufficiently investigating applicable laws and regulations that regulate the inclusion or use of controlled substances, including without limitation, the EU RoHS Directive, and using Renesas Electronics products in compliance with all these applicable laws and regulations. Renesas Electronics disclaims any and all liability for damages or losses occurring as a result of your noncompliance with applicable laws and regulations.
11. Renesas Electronics products and technologies shall not be used for or incorporated into any products or systems whose manufacture, use, or sale is prohibited under any applicable domestic or foreign laws or regulations. You shall comply with any applicable export control laws and regulations promulgated and administered by the governments of any countries asserting jurisdiction over the parties or transactions.
12. It is the responsibility of the buyer or distributor of Renesas Electronics products, or any other party who distributes, disposes of, or otherwise sells or transfers the product to a third party, to notify such third party in advance of the contents and conditions set forth in this document.
13. This document shall not be reprinted, reproduced or duplicated in any form, in whole or in part, without prior written consent of Renesas Electronics.
14. Please contact a Renesas Electronics sales office if you have any questions regarding the information contained in this document or Renesas Electronics products.

(Note1) "Renesas Electronics" as used in this document means Renesas Electronics Corporation and also includes its directly or indirectly controlled subsidiaries.

(Note2) "Renesas Electronics product(s)" means any product developed or manufactured by or for Renesas Electronics.

(Rev.5.0-1 October 2020)

Corporate Headquarters

TOYOSU FORESIA, 3-2-24 Toyosu,
Koto-ku, Tokyo 135-0061, Japan

www.renesas.com

Trademarks

Renesas and the Renesas logo are trademarks of Renesas Electronics Corporation. All trademarks and registered trademarks are the property of their respective owners.

Contact information

For further information on a product, technology, the most up-to-date version of a document, or your nearest sales office, please visit:

www.renesas.com/contact/.