

# RL78/G14, H8/36109

## Migration Guide from H8 to RL78: A/D Converter

---

### Introduction

This application note describes how to migrate the A/D Converter of the H8/36109 to the A/D Converter of the RL78/G14 (100-pin package).

### Target Device

RL78/G14, H8/36109

When using this application note with other Renesas MCUs, careful evaluation is recommended after making modifications to comply with the alternate MCU.

---

**Contents**

1. Functions of A/D Converter of H8/36109 and A/D Converter of RL78/G14 .....	3
2. Difference between A/D Converter .....	5
3. Comparison between Registers .....	6
4. Sample Code for A/D converter .....	7
5. Documents for Reference .....	7
Revision History .....	8

### 1. Functions of A/D Converter of H8/36109 and A/D Converter of RL78/G14

Table 1.1 shows the functions of the A/D Converter of H8/36109, and Table 1.2 shows the functions of the A/D Converter of RL78/G14.

Table 1.1 Function of A/D Converter of H8/36109

Function	Explanation
A/D conversion	This includes a 10-bit successive approximation A/D converter that allows up to 16 analog input channels to be selected. The A/D converter has single mode and scan mode. There are four 16-bit read-only registers for storing the A/D conversion result. The converted 10-bit data is stored in bits 15 to 6.

Table 1.2 Function of A/D Converter of RL78/G14

Function	Explanation
A/D conversion	The A/D converter is used to convert analog input signals into digital values, and is configured to control analog inputs, including up to 20 channels of A/D converter analog inputs (ANI0 to ANI14 and ANI16 to ANI20). The A/D converter has select mode and also scan mode. In select mode, one of the analog input channels is selected and A/D-converted. In scan mode, four consecutive analog input channels among ANI0-ANI14 are A/D-converted sequentially. Each time an A/D conversion operation ends, an interrupt request (INTAD) is generated. In addition, the converter can handle hardware triggers and has one-shot conversion mode as well as sequential conversion mode. The A/D converter has the 10-bit A/D conversion result register (ADCR), which holds the A/D conversion result in its upper ten bits, and also the 8-bit A/D conversion result register (ADCRH), which holds the A/D conversion result in its upper eight bits. Besides, 10-bit or 8-bit resolution can be selected. A hardware trigger signal in STOP mode can release STOP mode and so A/D conversion can be performed without operating the CPU (SNOOZE mode).

The A/D converter incorporated in the H8/36109 has the analog multiplexer, sample-and-hold circuit, comparator, successive approximations register, and A/D data registers.

Figure 1.1 shows a block diagram of the A/D Converter in the H8/36109.

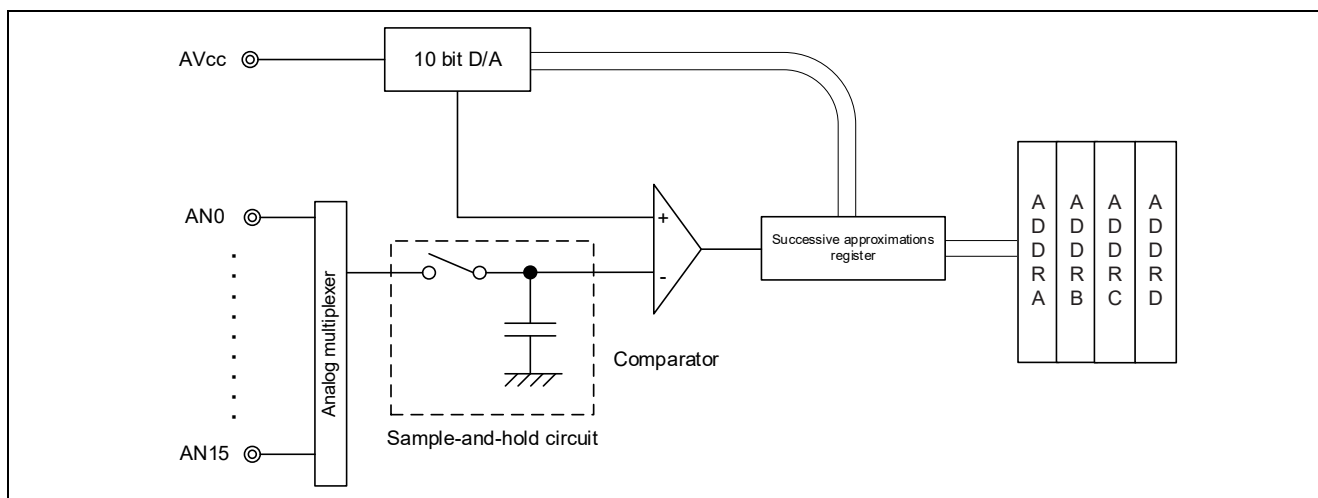

Figure 1.1 Block Diagram of A/D Converter (H8/36109)

The A/D converter incorporated in the RL78/G14 has the sample-and-hold circuit, A/D voltage comparator, Comparison voltage generator, successive approximation register, and A/D conversion result registers.

For the comparison voltage generator, either VDD and VSS pin pair or AVREFP and AVREFM pin pair can be selected to use.

Figure 1.2 shows a block diagram of the A/D Converter in the RL78/G14.

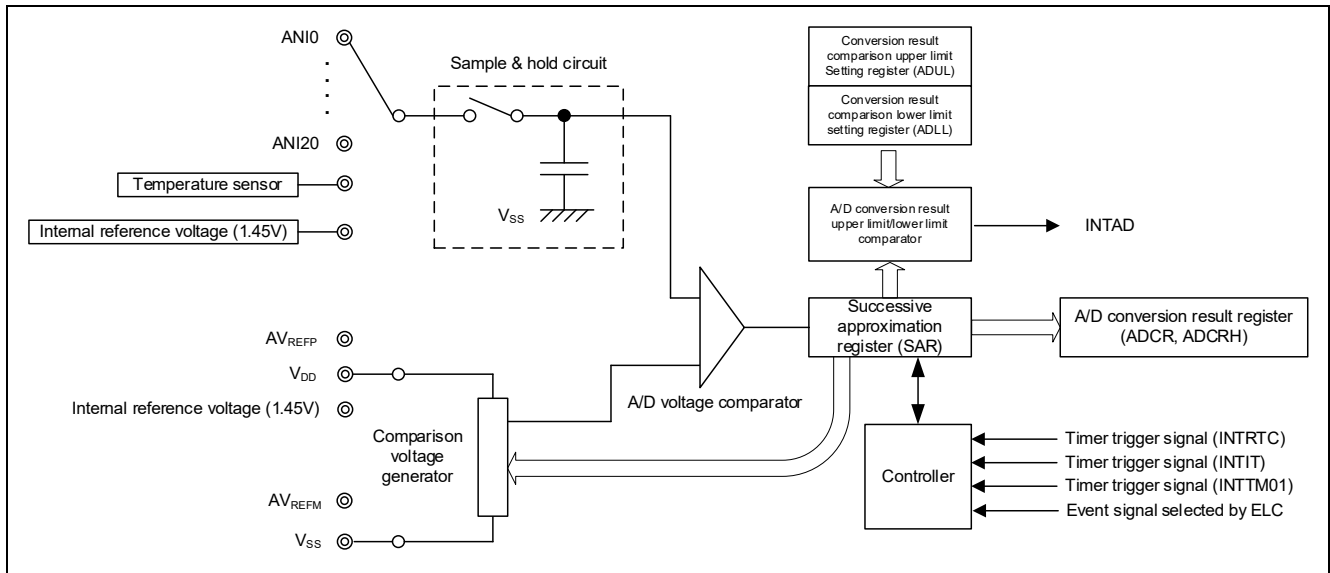

Figure 1.2 Block Diagram of A/D Converter (RL78/G14)

Table 1.3 shows the A/D converter functions of H8/36109 and RL78/G14.

Table 1.3 Correspondence between Functions

H8/36109 A/D Converter	RL78/G14 A/D Converter
Single mode	Select mode
Scan mode	Scan mode

The single mode of the A/D converter in the H8/36109 correspond to the select mode of the A/D converter in the RL78/G14.

The scan mode of the A/D converter in the H8/36109 correspond to the scan mode of the A/D converter in the RL78/G14.

## 2. Difference between A/D Converter

Table 2.1 summarizes the differences between the functions of the A/D converter in H8/36109 and the A/D converter in RL78/G14.

Table 2.1 Summary of differences between Function

Item	H8/36109 A/D converter	RL78/G14 (100-pin package) A/D converter
Control of A/D converter input clock supply	Setting the MSTAD bit in the MSTCR4 register to 0 (Initial value)	Setting the ADCEN bit in the PER0 register to 1
Resolution	10bit	10bit, 8bit
Absolute accuracy	$\pm 4.0$ LSB (Note1)	$\pm 3.5$ LSB (Note2)
Input channels	16 channels	20 channels
Conversion time (min.)	$3.5\mu\text{s}$ (Note3)	$2.125\mu\text{s}$ (Note4)
Successive approximations register	One	One
Data register	Four	One
Operating mode	- Single mode - Scan mode	- Select mode - Scan mode
Enables conversion operation	- Software (Setting the ADST bit to 1) - External trigger signal	- Software trigger - Hardware trigger
Stops conversion operation	- Automatic stop (Single mode) - Setting the ADST bit to 0 (Scan mode)	- Setting the ADCS bit to 0 - After A/D conversion ends, the ADCS bit is automatically cleared to 0, and the A/D converter enters the stop status.
Sample-and-hold circuit	Yes	Yes
Input sampling time	For CKS=0 31 states For CKS=1 15 states	Normal1 / Low-voltag mode1 number of sampling clock : $7 \times f_{AD}$ (Note5) Normal 2 / Low-voltag mode 2 number of sampling clock : $5 \times f_{AD}$ (Note 5)
SNOOZE Mode	None	Yes
Analog reference voltage	AVcc	AV <sub>REFP</sub> , V <sub>DD</sub> , internal reference voltage (1.45V)
Analog power supply pin	AVcc	AV <sub>REFP</sub>
Analog ground pin	AVss	AV <sub>REFM</sub>

Note 1. For H8/36109, V<sub>cc</sub>=3.0 to 5.5V, V<sub>ss</sub>=0.0V, AV<sub>cc</sub>=4.0 to 5.5V, Applicable Pin: AN0 to AN7

Note 2. For RL78/G14,  $1.8\text{ V} \leq \text{AV}_{\text{REFP}} \leq 5.5\text{ V}$ , Reference voltage (+) = AV<sub>REFP</sub>,  
Reference voltage (-) = AV<sub>REFM</sub> = 0 V, 10-bit resolution, Target pin: ANI2 - ANI14,  
Excludes quantization error ( $\pm 1/2$  LSB).

Note 3. 20-MHz operation

Note 4. For RL78/G14,  $1.8\text{ V} \leq \text{AV}_{\text{REFP}} \leq 5.5\text{ V}$ , Reference voltage (+) = AV<sub>REFP</sub>,  
Reference voltage (-) = AV<sub>REFM</sub> = 0 V,  $3.6\text{ V} \leq \text{V}_{\text{DD}} \leq 5.5\text{ V}$ , 10-bit resolution,  
Target pin: ANI2-ANI14

Note 5. f<sub>AD</sub>: Conversion Clock of A/D converter

### 3. Comparison between Registers

Table 3.1 compare the registers for the H8/36109 A/D converter and the registers for the RL78/G14 A/D converter.

Table 3.1 Comparison between Registers

Item	H8/36109 A/D converter	RL78/G14 A/D converter
Control of A/D converter input clock supply	MSTCR4 register MSTAD bit	PER0 register ADCEN bit
A/D data register	ADDRA register - ADDR0 register	ADCR register
A/D Control/Status Register	ADCSR register	None
A/D End Flag	ADCSR register ADF bit	None
A/D Interrupt Enable	ADCSR register ADIE bit	None
A/D Start	ADCSR register ADST bit	ADM0 register ADCS bit
Scan Mode	ADCSR register SCAN bit	ADM0 register ADM0 bit
Clock Select	ADCSR register CKS bit	ADM0 register FR2 - FR0 bit, LV1 bit, LV0 bit
Channel Select	ADCSR register CH2 - CH0 bit ADCR register CH3 bit	ADS register ADISS bit, ADS4 - ADS0 bit
A/D Control Register	ADCR register	None
Trigger Enable	ADCR register TRGE bit	ADM1 register ADTMD1 bit, ADTMD0 bit ADTRS1 bit, ADTRS0 bit
A/D voltage comparator operation control	None	ADM0 register ADCE bit
Specification of the A/D conversion mode	None	ADM1 register ADSCM bit
Selection of the + side reference voltage source of the A/D converter	None	ADM2 register ADREFP1 bit, ADREFP0 bit
Selection of the - side reference voltage of the A/D converter	None	ADM2 register ADREFM bit
Checking the upper limit and lower limit conversion result values	None	ADM2 register ADRCK bit
Specification of the SNOOZE mode	None	ADM2 register AWC bit
Selection of the A/D conversion resolution	None	ADM2 register ADTYP bit
Conversion result comparison upper limit setting register	None	ADUL register
Conversion result comparison lower limit setting register	None	ADLL register
A/D test register	None	ADTES register

#### 4. Sample Code for A/D converter

The sample code for the A/D converter is explained in the following application notes.

- RL78/G14 A/D Converter (Software Trigger and Sequential Conversion Modes) CC-RL (R01AN3817)
- RL78/G14 AD Converter which Uses Timer RJ as Activation Source (SNOOZE mode) CC-RL (R01AN2857)
- RL78/G14 A/D conversion using DTC realizes the low-power consumption of the system CC-RL (R01AN2863)

#### 5. Documents for Reference

User's Manual:

- RL78/G14 User's Manual: Hardware (R01UH0186)
- H8/36109 Group User's Manual: Hardware (R01UH0294)

The latest versions can be downloaded from the Renesas Electronics website.

Technical Update/Technical News:

The latest information can be downloaded from the Renesas Electronics website.

**Revision History**

Rev.	Date	Description	
		Page	Summary
1.00	Jun.08, 2020	-	First edition issued



## General Precautions in the Handling of Microprocessing Unit and Microcontroller Unit Products

The following usage notes are applicable to all Microprocessing unit and Microcontroller unit products from Renesas. For detailed usage notes on the products covered by this document, refer to the relevant sections of the document as well as any technical updates that have been issued for the products.

### 1. Precaution against Electrostatic Discharge (ESD)

A strong electrical field, when exposed to a CMOS device, can cause destruction of the gate oxide and ultimately degrade the device operation. Steps must be taken to stop the generation of static electricity as much as possible, and quickly dissipate it when it occurs. Environmental control must be adequate. When it is dry, a humidifier should be used. This is recommended to avoid using insulators that can easily build up static electricity.

Semiconductor devices must be stored and transported in an anti-static container, static shielding bag or conductive material. All test and measurement tools including work benches and floors must be grounded. The operator must also be grounded using a wrist strap. Semiconductor devices must not be touched with bare hands. Similar precautions must be taken for printed circuit boards with mounted semiconductor devices.

### 2. Processing at power-on

The state of the product is undefined at the time when power is supplied. The states of internal circuits in the LSI are indeterminate and the states of register settings and pins are undefined at the time when power is supplied. In a finished product where the reset signal is applied to the external reset pin, the states of pins are not guaranteed from the time when power is supplied until the reset process is completed. In a similar way, the states of pins in a product that is reset by an on-chip power-on reset function are not guaranteed from the time when power is supplied until the power reaches the level at which resetting is specified.

### 3. Input of signal during power-off state

Do not input signals or an I/O pull-up power supply while the device is powered off. The current injection that results from input of such a signal or I/O pull-up power supply may cause malfunction and the abnormal current that passes in the device at this time may cause degradation of internal elements. Follow the guideline for input signal during power-off state as described in your product documentation.

### 4. Handling of unused pins

Handle unused pins in accordance with the directions given under handling of unused pins in the manual. The input pins of CMOS products are generally in the high-impedance state. In operation with an unused pin in the open-circuit state, extra electromagnetic noise is induced in the vicinity of the LSI, an associated shoot-through current flows internally, and malfunctions occur due to the false recognition of the pin state as an input signal become possible.

### 5. Clock signals

After applying a reset, only release the reset line after the operating clock signal becomes stable. When switching the clock signal during program execution, wait until the target clock signal is stabilized. When the clock signal is generated with an external resonator or from an external oscillator during a reset, ensure that the reset line is only released after full stabilization of the clock signal. Additionally, when switching to a clock signal produced with an external resonator or by an external oscillator while program execution is in progress, wait until the target clock signal is stable.

### 6. Voltage application waveform at input pin

Waveform distortion due to input noise or a reflected wave may cause malfunction. If the input of the CMOS device stays in the area between  $V_{IL}$  (Max.) and  $V_{IH}$  (Min.) due to noise, for example, the device may malfunction. Take care to prevent chattering noise from entering the device when the input level is fixed, and also in the transition period when the input level passes through the area between  $V_{IL}$  (Max.) and  $V_{IH}$  (Min.).

### 7. Prohibition of access to reserved addresses

Access to reserved addresses is prohibited. The reserved addresses are provided for possible future expansion of functions. Do not access these addresses as the correct operation of the LSI is not guaranteed.

### 8. Differences between products

Before changing from one product to another, for example to a product with a different part number, confirm that the change will not lead to problems. The characteristics of a microprocessing unit or microcontroller unit products in the same group but having a different part number might differ in terms of internal memory capacity, layout pattern, and other factors, which can affect the ranges of electrical characteristics, such as characteristic values, operating margins, immunity to noise, and amount of radiated noise. When changing to a product with a different part number, implement a system-evaluation test for the given product.

## Notice

1. Descriptions of circuits, software and other related information in this document are provided only to illustrate the operation of semiconductor products and application examples. You are fully responsible for the incorporation or any other use of the circuits, software, and information in the design of your product or system. Renesas Electronics disclaims any and all liability for any losses and damages incurred by you or third parties arising from the use of these circuits, software, or information.
2. Renesas Electronics hereby expressly disclaims any warranties against and liability for infringement or any other claims involving patents, copyrights, or other intellectual property rights of third parties, by or arising from the use of Renesas Electronics products or technical information described in this document, including but not limited to, the product data, drawings, charts, programs, algorithms, and application examples.
3. No license, express, implied or otherwise, is granted hereby under any patents, copyrights or other intellectual property rights of Renesas Electronics or others.
4. You shall be responsible for determining what licenses are required from any third parties, and obtaining such licenses for the lawful import, export, manufacture, sales, utilization, distribution or other disposal of any products incorporating Renesas Electronics products, if required.
5. You shall not alter, modify, copy, or reverse engineer any Renesas Electronics product, whether in whole or in part. Renesas Electronics disclaims any and all liability for any losses or damages incurred by you or third parties arising from such alteration, modification, copying or reverse engineering.
6. Renesas Electronics products are classified according to the following two quality grades: "Standard" and "High Quality". The intended applications for each Renesas Electronics product depends on the product's quality grade, as indicated below.

"Standard": Computers; office equipment; communications equipment; test and measurement equipment; audio and visual equipment; home electronic appliances; machine tools; personal electronic equipment; industrial robots; etc.

"High Quality": Transportation equipment (automobiles, trains, ships, etc.); traffic control (traffic lights); large-scale communication equipment; key financial terminal systems; safety control equipment; etc.

Unless expressly designated as a high reliability product or a product for harsh environments in a Renesas Electronics data sheet or other Renesas Electronics document, Renesas Electronics products are not intended or authorized for use in products or systems that may pose a direct threat to human life or bodily injury (artificial life support devices or systems; surgical implantations; etc.), or may cause serious property damage (space system; undersea repeaters; nuclear power control systems; aircraft control systems; key plant systems; military equipment; etc.). Renesas Electronics disclaims any and all liability for any damages or losses incurred by you or any third parties arising from the use of any Renesas Electronics product that is inconsistent with any Renesas Electronics data sheet, user's manual or other Renesas Electronics document.
7. No semiconductor product is absolutely secure. Notwithstanding any security measures or features that may be implemented in Renesas Electronics hardware or software products, Renesas Electronics shall have absolutely no liability arising out of any vulnerability or security breach, including but not limited to any unauthorized access to or use of a Renesas Electronics product or a system that uses a Renesas Electronics product. RENESAS ELECTRONICS DOES NOT WARRANT OR GUARANTEE THAT RENESAS ELECTRONICS PRODUCTS, OR ANY SYSTEMS CREATED USING RENESAS ELECTRONICS PRODUCTS WILL BE INVULNERABLE OR FREE FROM CORRUPTION, ATTACK, VIRUSES, INTERFERENCE, HACKING, DATA LOSS OR THEFT, OR OTHER SECURITY INTRUSION ("Vulnerability Issues"). RENESAS ELECTRONICS DISCLAIMS ANY AND ALL RESPONSIBILITY OR LIABILITY ARISING FROM OR RELATED TO ANY VULNERABILITY ISSUES. FURTHERMORE, TO THE EXTENT PERMITTED BY APPLICABLE LAW, RENESAS ELECTRONICS DISCLAIMS ANY AND ALL WARRANTIES, EXPRESS OR IMPLIED, WITH RESPECT TO THIS DOCUMENT AND ANY RELATED OR ACCOMPANYING SOFTWARE OR HARDWARE, INCLUDING BUT NOT LIMITED TO THE IMPLIED WARRANTIES OF MERCHANTABILITY, OR FITNESS FOR A PARTICULAR PURPOSE.
8. When using Renesas Electronics products, refer to the latest product information (data sheets, user's manuals, application notes, "General Notes for Handling and Using Semiconductor Devices" in the reliability handbook, etc.), and ensure that usage conditions are within the ranges specified by Renesas Electronics with respect to maximum ratings, operating power supply voltage range, heat dissipation characteristics, installation, etc. Renesas Electronics disclaims any and all liability for any malfunctions, failure or accident arising out of the use of Renesas Electronics products outside of such specified ranges.
9. Although Renesas Electronics endeavors to improve the quality and reliability of Renesas Electronics products, semiconductor products have specific characteristics, such as the occurrence of failure at a certain rate and malfunctions under certain use conditions. Unless designated as a high reliability product or a product for harsh environments in a Renesas Electronics data sheet or other Renesas Electronics document, Renesas Electronics products are not subject to radiation resistance design. You are responsible for implementing safety measures to guard against the possibility of bodily injury, injury or damage caused by fire, and/or danger to the public in the event of a failure or malfunction of Renesas Electronics products, such as safety design for hardware and software, including but not limited to redundancy, fire control and malfunction prevention, appropriate treatment for aging degradation or any other appropriate measures. Because the evaluation of microcomputer software alone is very difficult and impractical, you are responsible for evaluating the safety of the final products or systems manufactured by you.
10. Please contact a Renesas Electronics sales office for details as to environmental matters such as the environmental compatibility of each Renesas Electronics product. You are responsible for carefully and sufficiently investigating applicable laws and regulations that regulate the inclusion or use of controlled substances, including without limitation, the EU RoHS Directive, and using Renesas Electronics products in compliance with all these applicable laws and regulations. Renesas Electronics disclaims any and all liability for damages or losses occurring as a result of your noncompliance with applicable laws and regulations.
11. Renesas Electronics products and technologies shall not be used for or incorporated into any products or systems whose manufacture, use, or sale is prohibited under any applicable domestic or foreign laws or regulations. You shall comply with any applicable export control laws and regulations promulgated and administered by the governments of any countries asserting jurisdiction over the parties or transactions.
12. It is the responsibility of the buyer or distributor of Renesas Electronics products, or any other party who distributes, disposes of, or otherwise sells or transfers the product to a third party, to notify such third party in advance of the contents and conditions set forth in this document.
13. This document shall not be reprinted, reproduced or duplicated in any form, in whole or in part, without prior written consent of Renesas Electronics.
14. Please contact a Renesas Electronics sales office if you have any questions regarding the information contained in this document or Renesas Electronics products.

(Note1) "Renesas Electronics" as used in this document means Renesas Electronics Corporation and also includes its directly or indirectly controlled subsidiaries.

(Note2) "Renesas Electronics product(s)" means any product developed or manufactured by or for Renesas Electronics.

(Rev.5.0-1 October 2020)

## Corporate Headquarters

TOYOSU FORESIA, 3-2-24 Toyosu,  
Koto-ku, Tokyo 135-0061, Japan  
[www.renesas.com](http://www.renesas.com)

## Trademarks

Renesas and the Renesas logo are trademarks of Renesas Electronics Corporation. All trademarks and registered trademarks are the property of their respective owners.

## Contact information

For further information on a product, technology, the most up-to-date version of a document, or your nearest sales office, please visit:  
[www.renesas.com/contact/](http://www.renesas.com/contact/).