

RH850/U2A-EVA Group

Main Oscillator application note

Introduction

This application note explains notes regarding crystal resonator usage of RH850/U2A-EVA Group (hereinafter referred to as U2A).

You are fully responsible for the incorporation or any other use of the information of this document in the design of your product or system.

Renesas Electronics assumes no responsibility for any losses incurred by you or third parties arising from the use of these information.

Target device

- RH850/U2A-EVA Group
 - RH850/U2A-EVA
 - RH850/U2A16
 - RH850/U2A8
 - RH850/U2A6

Contents

1.	Implementation notes of crystal resonator	2
1.1	Recommended crystal oscillation circuit	2
1.2	Board pattern example for stable oscillation	3
1.3	Unfavorable crystal oscillation circuits	7
1.4	Verified crystal resonator and reference oscillation circuit parameter	9

1. Implementation notes of crystal resonator

When a board around the crystal oscillator circuit is designed, it is necessary to refer this application note to prevent oscillation margin from declining and EMI level suppression.

1.1 Recommended crystal oscillation circuit

Figure.1 shows an example of recommended crystal oscillation circuit.

Damping resistor (R_d), load capacitor (C_{x1} , C_{x2}) and amplitude are implemented in U2A.

Basically, damping resistor (R_d) and load capacitor (C_{x1} , C_{x2}) implementation is not needed as they are already implemented inside. However, damping resistor and load capacitor may be needed depending on the parasitic capacitance caused by crystal resonator and the board. Please consult with crystal resonator manufacturer and decide the details.

As feedback resistor is built in the microcontroller, the implementation on the board is not necessary.

Please use AT-Cut type of crystal resonator.

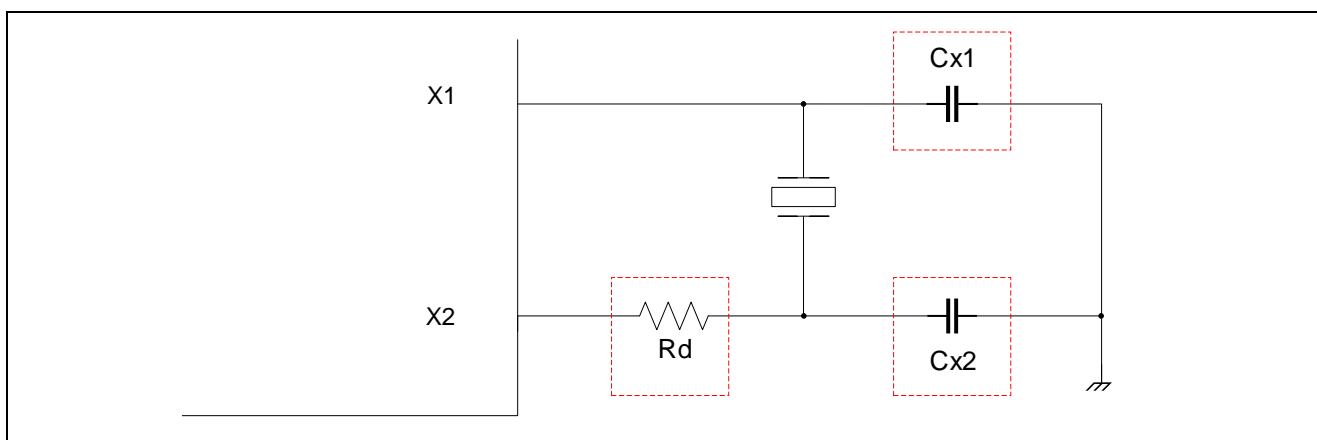

Figure.1 Example of crystal oscillation circuit

1.2 Board pattern example for stable oscillation

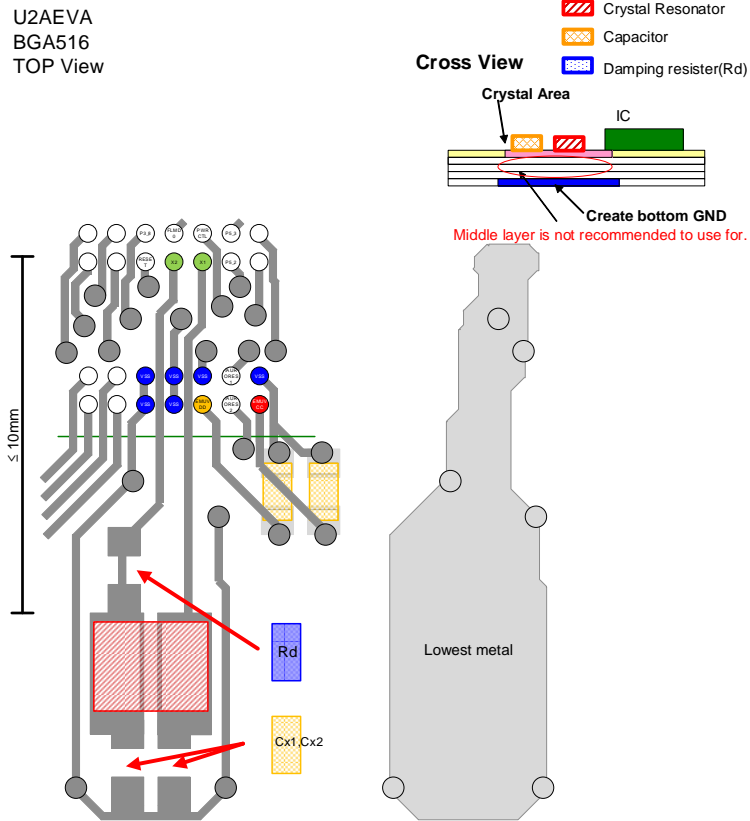

Figure.2 Board pattern example for stable oscillation(U2A-EVA BGA516)

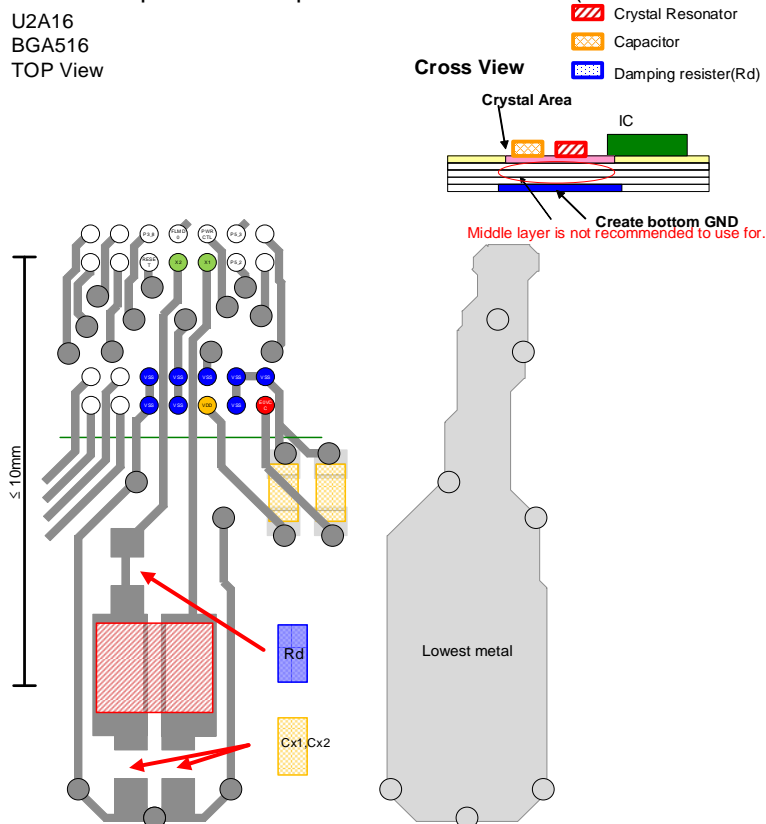

Figure.3 Board pattern example for stable oscillation(U2A16 BGA516)

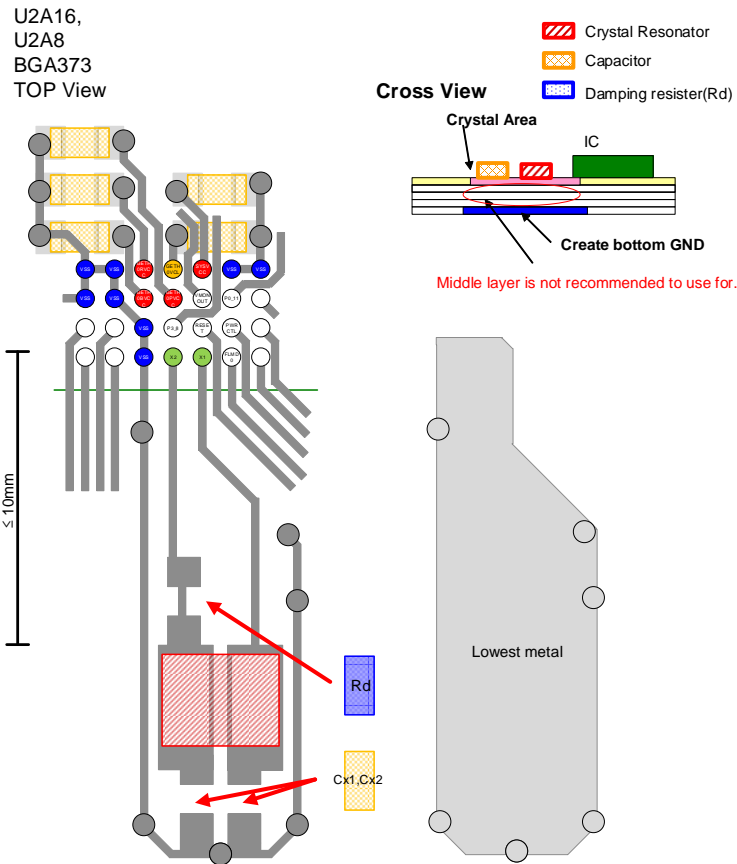

Figure.4 Board pattern example for stable oscillation(U2A16,U2A8 BGA373)

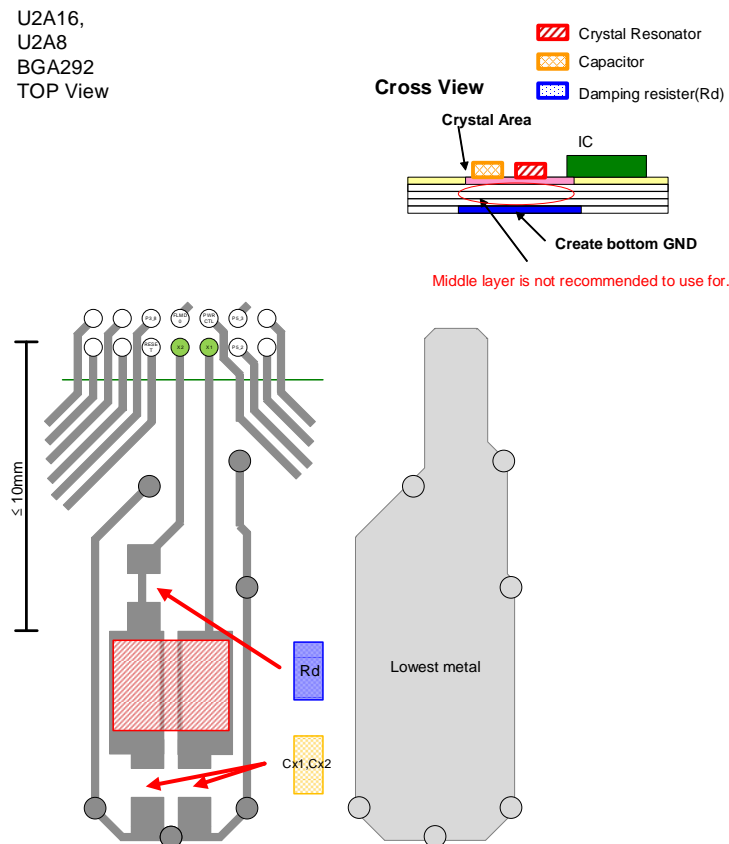

Figure.5 Board pattern example for stable oscillation(U2A16,U2A8 BGA292)

U2A6
HLQFP176, HLQFP144
TOP View

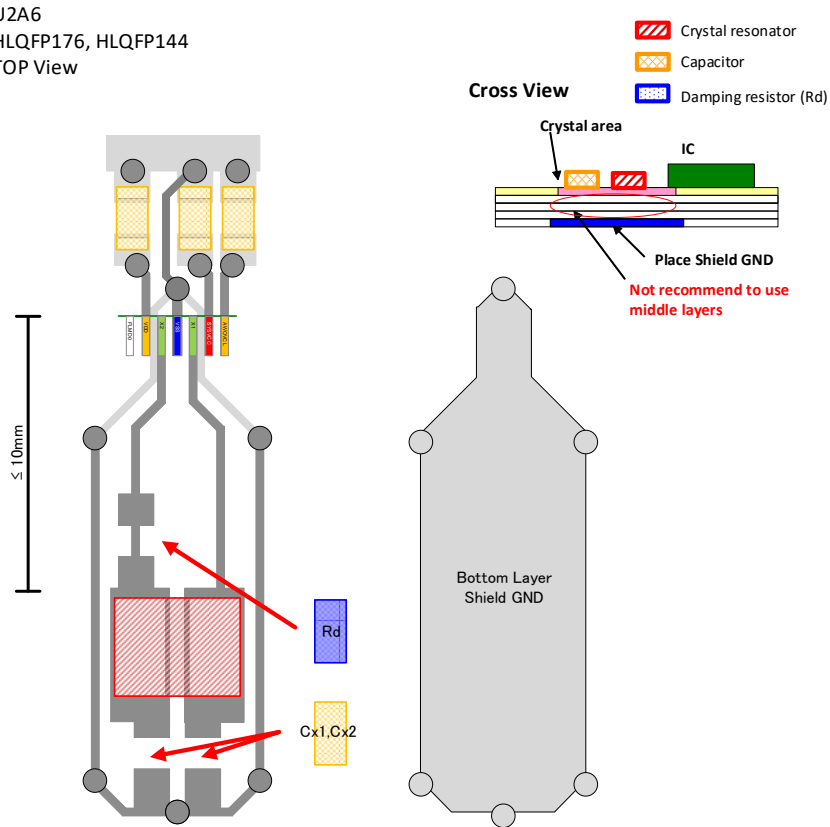

Figure.6 Board pattern example for stable oscillation (U2A6 QFP176, QFP144)

U2A6
BGA156
TOP View

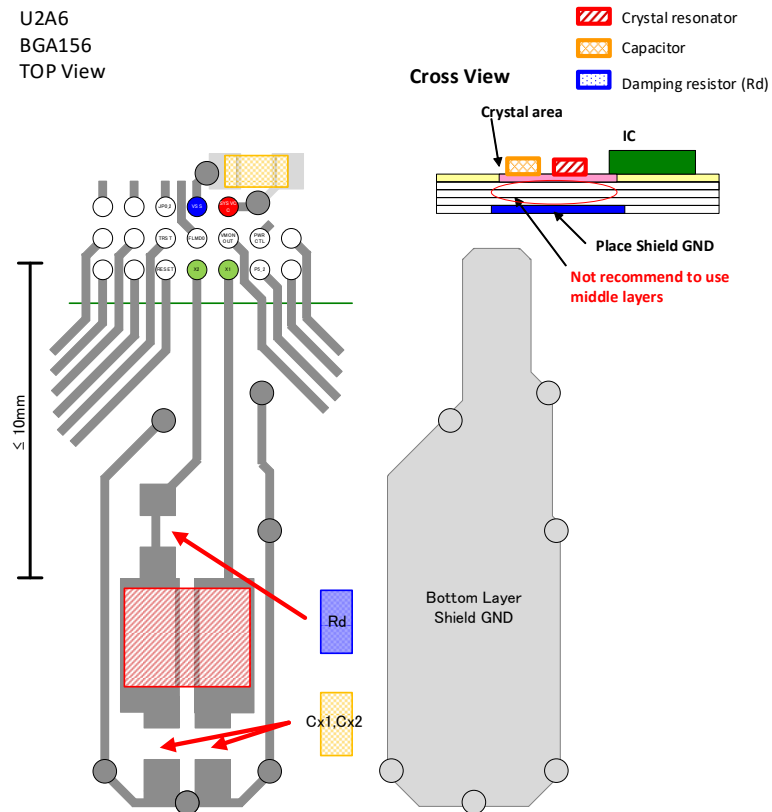

Figure.7 Board pattern example for stable oscillation (U2A6 BGA156)

Recommended wiring structure for stable oscillation

- Wiring at the top metal on the board (GND shield is needed)
- Apply GND shield at the bottom metal layer on the board
- Middle layers of the board is not used.
- Wiring length from terminal of the microcontroller to crystal is within 10mm.
- Signal wiring width is 0.1-0.3mm.
- Space between signal wiring and other wiring needs to be more than 0.3mm.
(X1, X2 wire space is also more than 0.3mm.)
- X1, X2 wiring resistance $< 2\Omega$
- X1, X2 wiring capacity $< 2\text{pF}$
- A bypass capacitor (0.1uF) should be connected between SYSVCC and VSS.

1.3 Unfavorable crystal oscillation circuits

Figure.8, Figure.9 shows unfavorable crystal oscillation circuits.

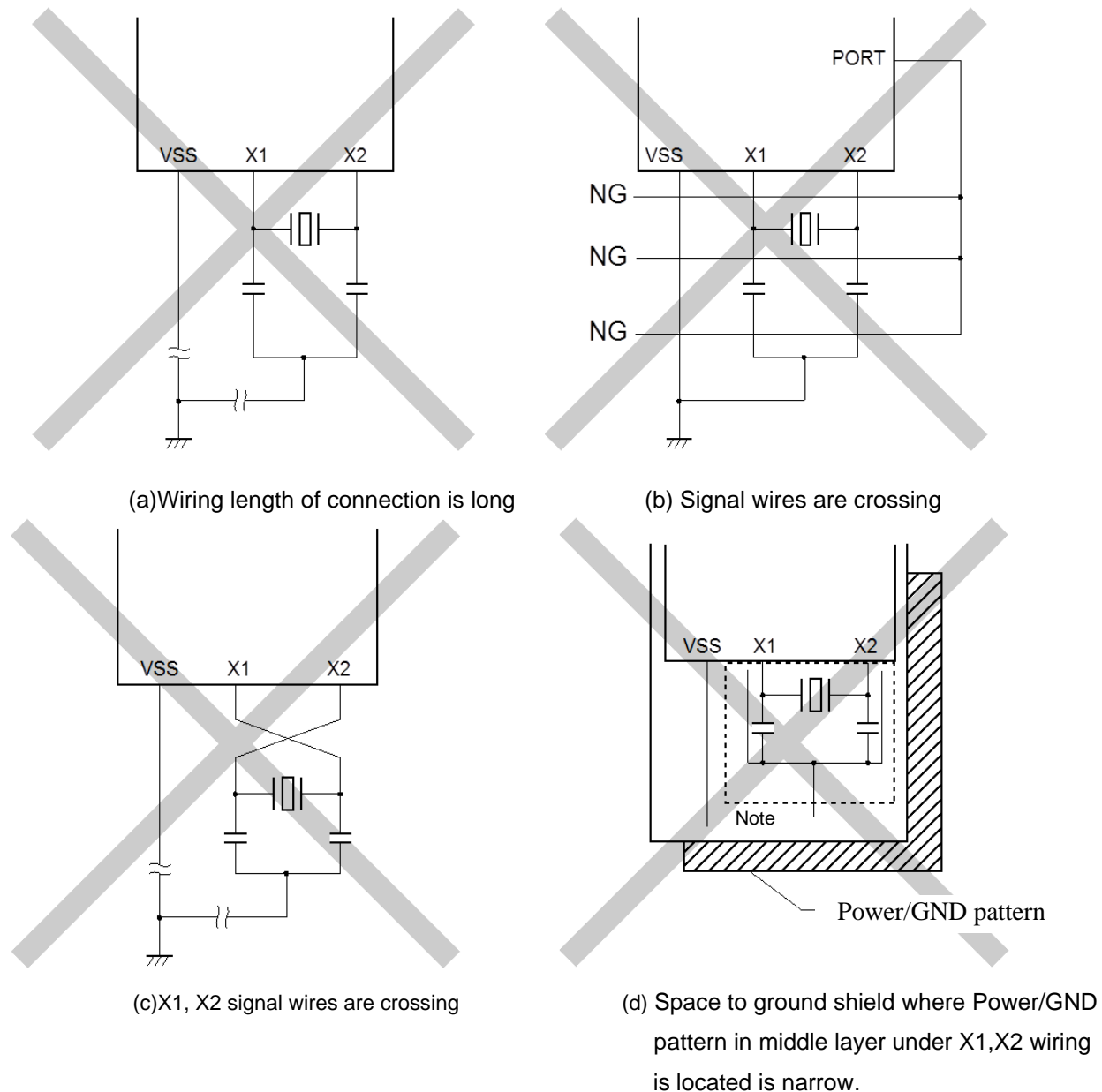

Note There is a concern that capacitance between pin X1 and pin X2 causes degradation of oscillation characteristics. Therefore, please avoid signal crossing. In case of parallel wiring, it is important to note wiring space and parallel length in order to prevent capacitance increase between the pins.

At multi-layer board, Please do not set power/GND pattern under X1, X2 terminals and crystal wire area(Dotted line in the Figure). Also please keep space more than 0.5mm from ground shield. If the space cannot be secured, there might be some impact on the oscillation characteristics due to parasitic capacitance increase.

Figure.8 Unfavorable crystal oscillation circuits (1/2)

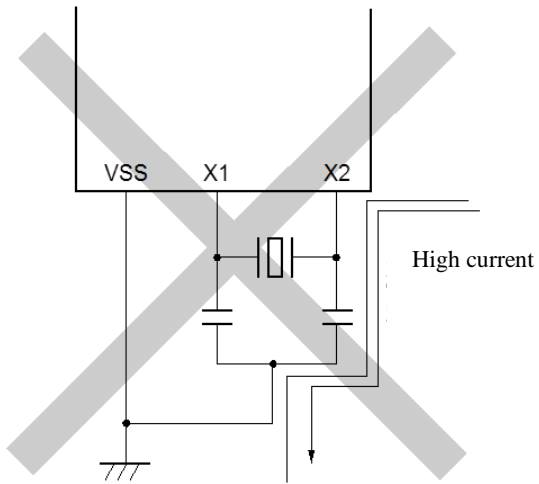

(e) Varied high current is near signal wiring

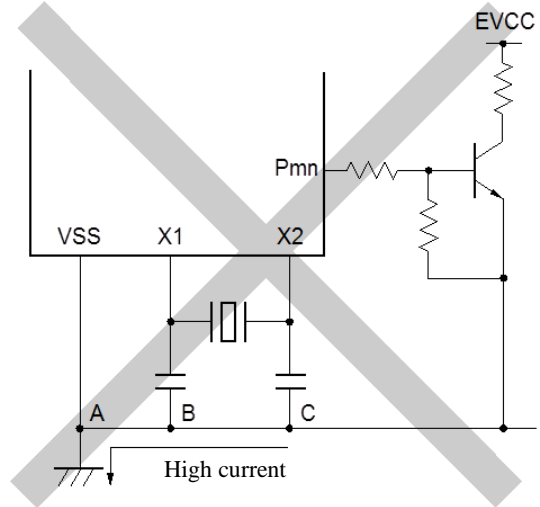

(f) Current is on ground line in the oscillation circuit.
(The potentials of A, B and C vary.)

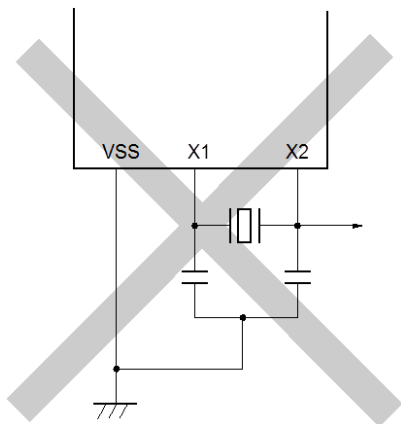

(g) Signal is taken out

Figure.9 Unfavorable crystal oscillation circuits.(2/2)

1.4 Verified resonator and reference oscillation circuit parameter

Verified crystal and ceramic resonator and reference circuit parameters are shown below. These reference oscillation circuit reference parameters are measured under certain condition using our evaluation board by the oscillator manufacturers. To confirm the oscillation characteristics with actual application, please consult with oscillator manufacturers to perform evaluation with actual product board.

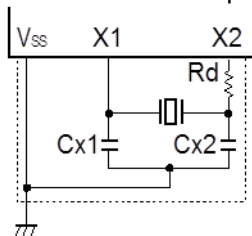

Figure.10 External circuit example

Table.1 Verified crystal resonator and reference circuit parameter*Note1(U2A-EVA(BGA516))

Manufacturer	Product name	CL (pF)	SMD/read	Frequency (MHz)	Oscillation circuit parameter (reference)*Note2			SYSVCC(V)	Option byte 10 (reference)								
					Cx1 (pF)	Cx2 (pF)	Rd (kΩ)		MOSC_EXCLKINPUT	MOSC_FREQ[2:0]	MOSC_CAP_SEL[3:0]	MOSC_SHTSTBY_A	MOSC_SHTSTBY_B	MOSC_AMP_SEL_A[2:0]	MOSC_AMP_SEL_B[2:0]	MOSC_RD_SEL_A[2:0]	MOSC_RD_SEL_B[2:0]
KYOCERA Crystal Device Corporation	CX3225GA	8	SMD	16	—	—	—	3.0 to 5.5V	1	000	0010	1	0	000	001	001	000
		8	SMD	20	—	—	—	3.0 to 5.5V	1	001	0011	1	0	011	010	001	000
		8	SMD	24	—	—	—	3.0 to 3.6V	1	010	0011	1	0	101	011	001	000
									4.5 to 5.5V	1	010	0011	1	0	100	011	001
		8	SMD	40	—	—	—	3.0 to 3.6V	1	011	0011	1	0	100	101	000	000
									4.5 to 5.5V	1	011	0010	1	0	011	100	000
	CX2016GR	8	SMD	16	—	—	—	3.0 to 5.5V	1	000	0011	1	0	110	100	001	000
		8	SMD	20	—	—	—	3.0 to 3.6V	1	001	0011	1	0	101	011	001	000
4.5 to 5.5V									1	001	0011	1	0	011	011	001	000
8	SMD	24	—	—	—	3.0 to 5.5V	1	010	0010	1	0	111	011	001	000		
NDK	NX3225GB	8	SMD	16	—	—	—	3.0 to 5.5V	1	000	0101	1	0	000	011	000	000
		8	SMD	20	—	—	—	3.0 to 5.5V	1	001	0101	1	0	011	100	000	000
		8	SMD	24	—	—	—	3.0 to 5.5V	1	010	0101	1	0	110	101	000	000
		6	SMD	40	—	—	—	3.0 to 5.5V	1	011	0000	1	0	110	111	000	000
	NX2016GC	8	SMD	16	—	—	—	3.0 to 5.5V	1	000	0010	1	0	111	111	001	001
		8	SMD	20	—	—	—	3.0 to 5.5V	1	001	0001	1	0	101	110	001	001
		8	SMD	24	—	—	—	3.0 to 5.5V	1	010	0000	1	0	100	111	000	001
KDS	DSX320GE	8	SMD	16	—	—	—	3.0 to 5.5V	1	000	0000	1	0	111	111	000	000
		8	SMD	20	—	—	—	3.0 to 5.5V	1	001	0000	1	0	111	111	000	000
		8	SMD	24	—	—	—	3.0 to 5.5V	1	010	0000	1	0	111	111	000	000
		8	SMD	40	—	—	—	3.0 to 5.5V	1	011	0000	1	0	100	111	000	000

Table.2 Verified crystal and ceramic resonator and reference circuit parameter*Note1(U2A16(BGA516))

Manufacturer	Product name	CL (pF)	SMD/ read	Frequency (MHz)	Oscillation circuit parameter (reference) ^{*Note2}			SYSVCC (V)	Option byte 10 (reference)								
					Cx1 (pF)	Cx2 (pF)	Rd (kΩ)		MOSC_EXCLKINP	MOSC_FREQ[2:0]	MOSC_CAP_SEL[3:0]	MOSC_SHTSTBY_A	MOSC_SHTSTBY_B	MOSC_AMP_SEL_A[2:0]	MOSC_AMP_SEL_B[2:0]	MOSC_RD_SEL_A[2:0]	MOSC_RD_SEL_B[2:0]
KYOCERA Crystal Device Corporation	CX3225GA	8	SMD	16	-	-	-	3.0 to 5.5V	1	000	0010	1	0	000	001	001	000
		8	SMD	20	-	-	-	3.0 to 5.5V	1	001	0010	1	0	000	010	010	000
		8	SMD	24	-	-	-	3.0 to 5.5V	1	010	0010	1	0	010	011	000	000
		8	SMD	40	-	-	-	3.0 to 5.5V	1	011	0010	1	0	100	101	000	000
	CX2016GR	8	SMD	16	-	-	-	3.0 to 5.5V	1	000	0010	1	0	110	100	100	000
		8	SMD	20	-	-	-	3.0 to 5.5V	1	001	0010	1	0	001	011	010	000
		8	SMD	24	-	-	-	3.0 to 5.5V	1	010	0010	1	0	111	100	100	000
		8	SMD	40	-	-	-	3.0 to 5.5V	1	011	0010	1	0	101	101	000	000
NDK	NX3225GB	8	SMD	16	-	-	-	3.0 to 5.5V	1	000	0101	1	0	000	011	000	000
		8	SMD	20	-	-	-	3.0 to 5.5V	1	001	0101	1	0	011	100	000	000
		8	SMD	24	-	-	-	3.0 to 5.5V	1	010	0101	1	0	110	101	000	000
		6	SMD	40	-	-	-	3.0 to 5.5V	1	011	0000	1	0	110	111	000	000
	NX2016GC	8	SMD	16	-	-	-	3.0 to 5.5V	1	000	0010	1	0	111	111	100	100
		8	SMD	20	-	-	-	3.0 to 5.5V	1	001	0001	1	0	101	110	100	100
		8	SMD	24	-	-	-	3.0 to 5.5V	1	010	0000	1	0	100	111	000	100
		6	SMD	40	-	-	-	3.0 to 5.5V	1	011	0000	1	0	111	111	000	010
KDS	DSX320GE	8	SMD	16	-	-	-	3.0 to 5.5V	1	000	0000	1	0	111	111	000	000
		8	SMD	20	-	-	-	3.0 to 5.5V	1	001	0000	1	0	111	111	000	000
		8	SMD	24	-	-	-	3.0 to 5.5V	1	010	0000	1	0	111	111	000	000
		8	SMD	40	-	-	-	3.0 to 5.5V	1	011	0000	1	0	100	111	000	000
	DSX210GE	8	SMD	20	-	-	-	3.0 to 5.5V	1	001	0000	1	0	111	111	000	011
		8	SMD	24	-	-	-	3.0 to 5.5V	1	010	0000	1	0	111	111	000	100
		8	SMD	40	-	-	-	3.0 to 5.5V	1	011	0000	1	0	100	111	000	000
Murata Manufacturing Co.	CSTNE16M0VH3C000R0	15	SMD	16	(15)	(15)	-	3.0 to 5.5V	1	001	0000	1	0	011	011	000	000
	CSTNE16M0VH3Y**0R0	15	SMD	16	(15)	(15)	-	3.0 to 5.5V	1	001	0000	1	0	011	011	000	000
	CSTNE20M0VH3C000R0	15	SMD	20	(15)	(15)	-	3.0 to 5.5V	1	001	0000	1	0	100	100	000	000
	CSTNE20M0VH3Y**0R0	15	SMD	20	(15)	(15)	-	3.0 to 5.5V	1	001	0000	1	0	101	101	000	000
	CSTNE24M0VH3C000R0	15	SMD	24	(15)	(15)	-	3.0 to 5.5V	1	010	0000	1	0	101	101	000	000
	XRCHA16M000F0A01R0	8	SMD	16	-	-	-	3.0 to 5.5V	1	000	1000	1	0	111	111	010	010
	XRCGE20M000F3A1BR0	8	SMD	20	-	-	-	3.0 to 5.5V	1	001	0101	1	0	111	111	011	011
	XRCGB24M000F3A18R0	6	SMD	24	-	-	-	3.0 to 5.5V	1	010	0100	1	0	111	111	011	011
	XRCHA16M000F0A12R0	8	SMD	16	-	-	-	3.0 to 5.5V	1	000	1000	1	0	111	111	010	010
	XRCHA20M000F0A12R0	8	SMD	20	-	-	-	3.0 to 5.5V	1	001	1000	1	0	111	111	001	001
	XRCHA24M000F0A12R0	8	SMD	24	-	-	-	3.0 to 5.5V	1	010	0111	1	0	111	111	001	001

Table 3 Verified crystal resonator and reference circuit parameter*Note1(U2A8(BGA373))

Manufacturer	Product name	CL (pF)	SMD/Read	Frequency (MHz)	Oscillation circuit parameter (reference)*Note2			SYSVCC (V)	Option byte 10 (reference)								
					C _{x1} (pF)	C _{x2} (pF)	R _d (kΩ)		MOSC_EXCLKINPUT	MOSC_FREQ[2:0]	MOSC_CAP_SEL[3:0]	MOSC_SHTSTBY_A	MOSC_SHTSTBY_B	MOSC_AMP_SEL_A[2:0]	MOSC_AMP_SEL_B[2:0]	MOSC_RD_SEL_A[2:0]	MOSC_RD_SEL_B[2:0]
KYOCERA Crystal Device Corporation	CX3225GA	8	SMD	16	—	—	—	3.0~5.5V	1	000	0010	1	0	000	001	001	000
		8	SMD	20	—	—	—	3.0~5.5V	1	001	0010	1	0	000	010	010	000
		8	SMD	24	—	—	—	3.0~5.5V	1	010	0010	1	0	010	011	000	000
		8	SMD	40	—	—	—	3.0~5.5V	1	011	0010	1	0	100	101	000	000
	CX2016GR	8	SMD	16	—	—	—	3.0~5.5V	1	000	0010	1	0	110	100	100	000
		8	SMD	20	—	—	—	3.0~5.5V	1	001	0010	1	0	001	011	010	000
		8	SMD	24	—	—	—	3.0~5.5V	1	010	0010	1	0	111	100	100	000
		8	SMD	40	—	—	—	3.0~5.5V	1	011	0010	1	0	101	101	000	000
NDK	NX3225GB	8	SMD	16	—	—	—	3.0~5.5V	1	000	0110	1	0	000	011	000	000
		8	SMD	20	—	—	—	3.0~5.5V	1	001	0111	1	0	011	100	000	000
		8	SMD	24	—	—	—	3.0~5.5V	1	010	0110	1	0	110	101	000	000
		6	SMD	40	—	—	—	3.0~5.5V	1	011	0001	1	0	110	111	000	000
	NX2016GC	8	SMD	16	—	—	—	3.0~5.5V	1	000	0011	1	0	111	111	100	100
		8	SMD	20	—	—	—	3.0~5.5V	1	001	0010	1	0	101	110	100	100
		8	SMD	24	—	—	—	3.0~5.5V	1	010	0001	1	0	100	111	000	100
		6	SMD	40	—	—	—	3.0~5.5V	1	011	0001	1	0	111	111	000	001
KDS	DSX320GE	8	SMD	16	—	—	—	3.0~5.5V	1	000	0000	1	0	111	111	000	000
		8	SMD	20	—	—	—	3.0~5.5V	1	001	0000	1	0	111	111	000	000
		8	SMD	24	—	—	—	3.0~5.5V	1	010	0000	1	0	111	111	000	000
		8	SMD	40	—	—	—	3.0~5.5V	1	011	0000	1	0	100	111	000	000
	DSX210GE	8	SMD	20	—	—	—	3.0~5.5V	1	001	0000	1	0	111	111	000	011
		8	SMD	24	—	—	—	3.0~5.5V	1	010	0000	1	0	111	111	000	100
		8	SMD	40	—	—	—	3.0~5.5V	1	011	0000	1	0	100	111	000	000

Table 4 Verified crystal resonator and reference circuit parameter*Note1 (U2A6(BGA292))

Manufacturer	Product name	CL (pF)	SMD/Read	Frequency (MHz)	Oscillation circuit parameter (reference) ^{*Note2}			SYSVCC (V)	Option byte 10 (reference)								
					C _{x1} (pF)	C _{x2} (pF)	R _d (kΩ)		MOSC_EXCLKINPUTZ	MOSC_FREQ[2:0]	MOSC_CAP_SEL[3:0]	MOSC_SHTSTBY_A	MOSC_SHTSTBY_B	MOSC_AMP_SEL_A[2:0]	MOSC_AMP_SEL_B[2:0]	MOSC_RD_SEL_A[2:0]	MOSC_RD_SEL_B[2:0]
KYOCERA Crystal Device Corporation	CX3225GA	8	SMD	16	-	-	-	3.0~5.5V	1	000	0010	1	0	000	001	001	000
		8	SMD	20	-	-	-	3.0~5.5V	1	001	0010	1	0	000	010	010	000
		8	SMD	24	-	-	-	3.0~5.5V	1	010	0010	1	0	010	011	000	000
		8	SMD	40	-	-	-	3.0~5.5V	1	011	0010	1	0	100	101	000	000
	CX2016GR	8	SMD	16	-	-	-	3.0~5.5V	1	000	0010	1	0	110	100	100	000
		8	SMD	20	-	-	-	3.0~5.5V	1	001	0010	1	0	001	011	010	000
		8	SMD	24	-	-	-	3.0~5.5V	1	010	0010	1	0	111	100	100	000
		8	SMD	40	-	-	-	3.0~5.5V	1	011	0010	1	0	101	101	000	000
NDK	NX3225GB	8	SMD	16	-	-	-	3.0~5.5V	1	000	0110	1	0	000	011	000	000
		8	SMD	20	-	-	-	3.0~5.5V	1	001	0111	1	0	011	100	000	000
		8	SMD	24	-	-	-	3.0~5.5V	1	010	0110	1	0	110	101	000	000
		6	SMD	40	-	-	-	3.0~5.5V	1	011	0001	1	0	110	111	000	000
	NX2016GC	8	SMD	16	-	-	-	3.0~5.5V	1	000	0011	1	0	111	111	100	100
		8	SMD	20	-	-	-	3.0~5.5V	1	001	0010	1	0	101	110	100	100
		8	SMD	24	-	-	-	3.0~5.5V	1	010	0001	1	0	100	111	000	100
		6	SMD	40	-	-	-	3.0~5.5V	1	011	0001	1	0	111	111	000	001
KDS	DSX320GE	8	SMD	16	-	-	-	3.0~5.5V	1	000	0010	1	0	111	111	000	000
		8	SMD	20	-	-	-	3.0~5.5V	1	001	0001	1	0	111	111	000	000
		8	SMD	24	-	-	-	3.0~5.5V	1	010	0001	1	0	111	111	000	000
		8	SMD	40	-	-	-	3.0~5.5V	1	011	0001	1	0	111	111	000	000
	DSX210GE	8	SMD	20	-	-	-	3.0~5.5V	1	000	0001	1	0	111	111	000	011
		8	SMD	24	-	-	-	3.0~5.5V	1	001	0001	1	0	111	111	000	100
		8	SMD	24	-	-	-	3.0~5.5V	1	010	0001	1	0	111	111	000	000
		8	SMD	40	-	-	-	3.0~5.5V	1	011	0001	1	0	111	111	000	000
Murata Manufacturing Co.	CSTNE16M0VH3C000R0	15	SMD	16	(15)	(15)	-	3.0~5.5V	1	000	0000	1	0	011	011	000	000
	CSTNE16M0VH3Y**0R0	15	SMD	16	(15)	(15)	-	3.0~5.5V	1	000	0000	1	0	011	011	000	000
	CSTNE16M0VH5T000R0	33	SMD	16	(33)	(33)	-	3.0~5.5V	1	000	0000	1	0	011	011	000	000
	CSTNE20M0VH3C000R0	15	SMD	20	(15)	(15)	-	3.0~5.5V	1	001	0000	1	0	100	100	000	000
	CSTNE20M0VH3Y**0R0	15	SMD	20	(15)	(15)	-	3.0~5.5V	1	001	0000	1	0	100	100	000	000
	CSTNE20M0VH5T000R0	33	SMD	20	(33)	(33)	-	3.0~5.5V	1	001	0000	1	0	100	100	000	000
	CSTNE24M0VH3C000R0	15	SMD	24	(15)	(15)	-	3.0~5.5V	1	010	0000	1	0	101	101	000	000
	CSTNE24M0VH5T000R0	33	SMD	24	(33)	(33)	-	3.0~5.5V	1	010	0000	1	0	101	101	000	000
	XRCGE20M000F3A1BR0	8	SMD	20	-	-	-	3.0~5.5V	1	001	0101	1	0	111	111	011	011
	XRCGB24M000F3A18R0	6	SMD	24	-	-	-	3.0~5.5V	1	010	0100	1	0	111	111	011	011

- Note1. Verified crystal and ceramic resonator and circuit reference parameters shown above ,which are based on the information provided by the oscillator manufacturers, are only for reference, not guaranteed. Oscillation circuit reference parameters are measured under certain condition using our evaluation board by the oscillator manufacturers. As oscillation depends on the crystal and ceramic resonator itself and the board design, to confirm whether it works properly, please ask oscillator manufactures to perform the evaluation using actual board. Also the above is the conditions for crystal and ceramic resonator which is connected to a microcontroller to oscillate, not conditions for microcontroller's operations. As for the operation conditions of the microcontroller, please use within DC, AC characteristic.
- Note2. As feedback resistor is built in the microcontroller, the implementation on the board is not necessary.

Revisions

Rev.	Issued date	Revised contents	
		Page	contents
0.10	2019.03.08	10	First edition
0.70	2020.03.20	4	Added Figure 4 (Board pattern example of BGA373)
		8, 9	Added verified crystal resonator and reference parameter.
1.00	2020.10.05	9,10	Modified Table2. Added verified crystal/Ceramic resonators provided by Murata Manufacturing Co.
1.10	2021.07.02	11	Added verified crystal resonator and reference parameters for U2A8.
1.20	2022.06.30	5	Added board pattern examples of QFP176, QFP144, and BGA156 packages.
		12	Added verified crystal resonator and reference parameters for U2A6.

General Precautions in the Handling of Microprocessing Unit and Microcontroller Unit Products

The following usage notes are applicable to all Microprocessing unit and Microcontroller unit products from Renesas. For detailed usage notes on the products covered by this document, refer to the relevant sections of the document as well as any technical updates that have been issued for the products.

1. Precaution against Electrostatic Discharge (ESD)

A strong electrical field, when exposed to a CMOS device, can cause destruction of the gate oxide and ultimately degrade the device operation. Steps must be taken to stop the generation of static electricity as much as possible, and quickly dissipate it when it occurs. Environmental control must be adequate. When it is dry, a humidifier should be used. This is recommended to avoid using insulators that can easily build up static electricity. Semiconductor devices must be stored and transported in an anti-static container, static shielding bag or conductive material. All test and measurement tools including work benches and floors must be grounded. The operator must also be grounded using a wrist strap. Semiconductor devices must not be touched with bare hands. Similar precautions must be taken for printed circuit boards with mounted semiconductor devices.

2. Processing at power-on

The state of the product is undefined at the time when power is supplied. The states of internal circuits in the LSI are indeterminate and the states of register settings and pins are undefined at the time when power is supplied. In a finished product where the reset signal is applied to the external reset pin, the states of pins are not guaranteed from the time when power is supplied until the reset process is completed. In a similar way, the states of pins in a product that is reset by an on-chip power-on reset function are not guaranteed from the time when power is supplied until the power reaches the level at which resetting is specified.

3. Input of signal during power-off state

Do not input signals or an I/O pull-up power supply while the device is powered off. The current injection that results from input of such a signal or I/O pull-up power supply may cause malfunction and the abnormal current that passes in the device at this time may cause degradation of internal elements. Follow the guideline for input signal during power-off state as described in your product documentation.

4. Handling of unused pins

Handle unused pins in accordance with the directions given under handling of unused pins in the manual. The input pins of CMOS products are generally in the high-impedance state. In operation with an unused pin in the open-circuit state, extra electromagnetic noise is induced in the vicinity of the LSI, an associated shoot-through current flows internally, and malfunctions occur due to the false recognition of the pin state as an input signal become possible.

5. Clock signals

After applying a reset, only release the reset line after the operating clock signal becomes stable. When switching the clock signal during program execution, wait until the target clock signal is stabilized. When the clock signal is generated with an external resonator or from an external oscillator during a reset, ensure that the reset line is only released after full stabilization of the clock signal. Additionally, when switching to a clock signal produced with an external resonator or by an external oscillator while program execution is in progress, wait until the target clock signal is stable.

6. Voltage application waveform at input pin

Waveform distortion due to input noise or a reflected wave may cause malfunction. If the input of the CMOS device stays in the area between V_{IL} (Max.) and V_{IH} (Min.) due to noise, for example, the device may malfunction. Take care to prevent chattering noise from entering the device when the input level is fixed, and also in the transition period when the input level passes through the area between V_{IL} (Max.) and V_{IH} (Min.).

7. Prohibition of access to reserved addresses

Access to reserved addresses is prohibited. The reserved addresses are provided for possible future expansion of functions. Do not access these addresses as the correct operation of the LSI is not guaranteed.

8. Differences between products

Before changing from one product to another, for example to a product with a different part number, confirm that the change will not lead to problems. The characteristics of a microprocessing unit or microcontroller unit products in the same group but having a different part number might differ in terms of internal memory capacity, layout pattern, and other factors, which can affect the ranges of electrical characteristics, such as characteristic values, operating margins, immunity to noise, and amount of radiated noise. When changing to a product with a different part number, implement a system-evaluation test for the given product.

Notice

1. Descriptions of circuits, software and other related information in this document are provided only to illustrate the operation of semiconductor products and application examples. You are fully responsible for the incorporation or any other use of the circuits, software, and information in the design of your product or system. Renesas Electronics disclaims any and all liability for any losses and damages incurred by you or third parties arising from the use of these circuits, software, or information.
2. Renesas Electronics hereby expressly disclaims any warranties against and liability for infringement or any other claims involving patents, copyrights, or other intellectual property rights of third parties, by or arising from the use of Renesas Electronics products or technical information described in this document, including but not limited to, the product data, drawings, charts, programs, algorithms, and application examples.
3. No license, express, implied or otherwise, is granted hereby under any patents, copyrights or other intellectual property rights of Renesas Electronics or others.
4. You shall be responsible for determining what licenses are required from any third parties, and obtaining such licenses for the lawful import, export, manufacture, sales, utilization, distribution or other disposal of any products incorporating Renesas Electronics products, if required.
5. You shall not alter, modify, copy, or reverse engineer any Renesas Electronics product, whether in whole or in part. Renesas Electronics disclaims any and all liability for any losses or damages incurred by you or third parties arising from such alteration, modification, copying or reverse engineering.
6. Renesas Electronics products are classified according to the following two quality grades: "Standard" and "High Quality". The intended applications for each Renesas Electronics product depends on the product's quality grade, as indicated below.

"Standard": Computers; office equipment; communications equipment; test and measurement equipment; audio and visual equipment; home electronic appliances; machine tools; personal electronic equipment; industrial robots; etc.

"High Quality": Transportation equipment (automobiles, trains, ships, etc.); traffic control (traffic lights); large-scale communication equipment; key financial terminal systems; safety control equipment; etc.

Unless expressly designated as a high reliability product or a product for harsh environments in a Renesas Electronics data sheet or other Renesas Electronics document, Renesas Electronics products are not intended or authorized for use in products or systems that may pose a direct threat to human life or bodily injury (artificial life support devices or systems; surgical implantations; etc.), or may cause serious property damage (space system; undersea repeaters; nuclear power control systems; aircraft control systems; key plant systems; military equipment; etc.). Renesas Electronics disclaims any and all liability for any damages or losses incurred by you or any third parties arising from the use of any Renesas Electronics product that is inconsistent with any Renesas Electronics data sheet, user's manual or other Renesas Electronics document.

7. No semiconductor product is absolutely secure. Notwithstanding any security measures or features that may be implemented in Renesas Electronics hardware or software products, Renesas Electronics shall have absolutely no liability arising out of any vulnerability or security breach, including but not limited to any unauthorized access to or use of a Renesas Electronics product or a system that uses a Renesas Electronics product. RENESAS ELECTRONICS DOES NOT WARRANT OR GUARANTEE THAT RENESAS ELECTRONICS PRODUCTS, OR ANY SYSTEMS CREATED USING RENESAS ELECTRONICS PRODUCTS WILL BE INVULNERABLE OR FREE FROM CORRUPTION, ATTACK, VIRUSES, INTERFERENCE, HACKING, DATA LOSS OR THEFT, OR OTHER SECURITY INTRUSION ("Vulnerability Issues"). RENESAS ELECTRONICS DISCLAIMS ANY AND ALL RESPONSIBILITY OR LIABILITY ARISING FROM OR RELATED TO ANY VULNERABILITY ISSUES. FURTHERMORE, TO THE EXTENT PERMITTED BY APPLICABLE LAW, RENESAS ELECTRONICS DISCLAIMS ANY AND ALL WARRANTIES, EXPRESS OR IMPLIED, WITH RESPECT TO THIS DOCUMENT AND ANY RELATED OR ACCOMPANYING SOFTWARE OR HARDWARE, INCLUDING BUT NOT LIMITED TO THE IMPLIED WARRANTIES OF MERCHANTABILITY, OR FITNESS FOR A PARTICULAR PURPOSE.
8. When using Renesas Electronics products, refer to the latest product information (data sheets, user's manuals, application notes, "General Notes for Handling and Using Semiconductor Devices" in the reliability handbook, etc.), and ensure that usage conditions are within the ranges specified by Renesas Electronics with respect to maximum ratings, operating power supply voltage range, heat dissipation characteristics, installation, etc. Renesas Electronics disclaims any and all liability for any malfunctions, failure or accident arising out of the use of Renesas Electronics products outside of such specified ranges.
9. Although Renesas Electronics endeavors to improve the quality and reliability of Renesas Electronics products, semiconductor products have specific characteristics, such as the occurrence of failure at a certain rate and malfunctions under certain use conditions. Unless designated as a high reliability product or a product for harsh environments in a Renesas Electronics data sheet or other Renesas Electronics document, Renesas Electronics products are not subject to radiation resistance design. You are responsible for implementing safety measures to guard against the possibility of bodily injury, injury or damage caused by fire, and/or danger to the public in the event of a failure or malfunction of Renesas Electronics products, such as safety design for hardware and software, including but not limited to redundancy, fire control and malfunction prevention, appropriate treatment for aging degradation or any other appropriate measures. Because the evaluation of microcomputer software alone is very difficult and impractical, you are responsible for evaluating the safety of the final products or systems manufactured by you.
10. Please contact a Renesas Electronics sales office for details as to environmental matters such as the environmental compatibility of each Renesas Electronics product. You are responsible for carefully and sufficiently investigating applicable laws and regulations that regulate the inclusion or use of controlled substances, including without limitation, the EU RoHS Directive, and using Renesas Electronics products in compliance with all these applicable laws and regulations. Renesas Electronics disclaims any and all liability for damages or losses occurring as a result of your noncompliance with applicable laws and regulations.
11. Renesas Electronics products and technologies shall not be used for or incorporated into any products or systems whose manufacture, use, or sale is prohibited under any applicable domestic or foreign laws or regulations. You shall comply with any applicable export control laws and regulations promulgated and administered by the governments of any countries asserting jurisdiction over the parties or transactions.
12. It is the responsibility of the buyer or distributor of Renesas Electronics products, or any other party who distributes, disposes of, or otherwise sells or transfers the product to a third party, to notify such third party in advance of the contents and conditions set forth in this document.
13. This document shall not be reprinted, reproduced or duplicated in any form, in whole or in part, without prior written consent of Renesas Electronics.
14. Please contact a Renesas Electronics sales office if you have any questions regarding the information contained in this document or Renesas Electronics products.

(Note1) "Renesas Electronics" as used in this document means Renesas Electronics Corporation and also includes its directly or indirectly controlled subsidiaries.

(Note2) "Renesas Electronics product(s)" means any product developed or manufactured by or for Renesas Electronics.

(Rev.5.0-1 October 2020)

Corporate Headquarters

TOYOSU FORESIA, 3-2-24 Toyosu,
Koto-ku, Tokyo 135-0061, Japan
www.renesas.com

Trademarks

Renesas and the Renesas logo are trademarks of Renesas Electronics Corporation. All trademarks and registered trademarks are the property of their respective owners.

Contact information

For further information on a product, technology, the most up-to-date version of a document, or your nearest sales office, please visit:
www.renesas.com/contact/.