R8C/38C Group

Timer RD (PWM3 Mode)

R01AN0083EJ0100

Rev.1.00

Sep. 27, 2010

1. Abstract

This document describes a setting method and an application example for timer RD in PWM3 mode in the R8C/38C Group.

2. Introduction

The application example described in this document applies to the following microcomputer (MCU) and parameter:

- MCU: R8C/38C Group
- XIN clock frequency: 20 MHz

This application note can be used with other R8C Family MCUs which have the same special function registers (SFRs) as the above group. Check the manual for any modifications to functions. Careful evaluation is recommended before using the program described in this application note.

3. Application Example

3.1 Program Outline

Two PWM waveforms with 200 μs periods are output. The PWM period is generated at a compare match of timer RD counter 0 (TRD0) and general register A0 (TRDGRA0). PWM change points are generated at the compare match of the TRD0 register and general registers TRDGRA1, TRDGRB0, and TRDGRB1. An interrupt is generated at the compare match of registers TRD0 and TRDGRA0. Output signals are as follows:

$$\begin{aligned} \text{TRDIOA0 pin: Active high level } 60 \mu\text{s} &= 1/20 \text{ MHz} \times (\text{TRDGRA0} - \text{TRDGRA1}) \\ &= 50 \text{ ns} \times (3999 - 2799) = 50 \text{ ns} \times 1200 \end{aligned}$$

$$\begin{aligned} \text{TRDIOB0 pin: Active high level } 60 \mu\text{s} &= 1/20 \text{ MHz} \times (\text{TRDGRB0} - \text{TRDGRB1}) \\ &= 50 \text{ ns} \times (1999 - 799) = 50 \text{ ns} \times 1200 \end{aligned}$$

The 200 μs PWM period is set to the TRDGRA0 register.
 $200 \mu\text{s} = 1/20 \text{ MHz} \times (\text{TRDGRA0} + 1) = 50 \text{ ns} \times 4000$

PWM output change of TRDIOA0 pin (Set the active level timing in the TRDGRA1 register.)

$$140 \mu\text{s} = 1/20 \text{ MHz} \times (\text{TRDGRA1} + 1) = 50 \text{ ns} \times 2800$$

PWM output change of TRDIOB0 pin (Set the timing that returns to initial output level in the TRDGRB0 register.)

$$100 \mu\text{s} = 1/20 \text{ MHz} \times (\text{TRDGRB0} + 1) = 50 \text{ ns} \times 2000$$

PWM output change of TRDIOB0 pin (Set the active level timing in the TRDGRB1 register.)

$$40 \mu\text{s} = 1/20 \text{ MHz} \times (\text{TRDGRB1} + 1) = 50 \text{ ns} \times 800$$

Settings

- Use f1 (XIN clock: 20 MHz) as the count source.
- Clear the TRD0 register at the compare match with the TRDGRA0 register.
- Select TRDGRA0 and TRDGRB0 pin output levels as active high and the initial output level as inactive low.
- Output an active high level from the TRDIOA0 output pin at the compare match of registers TRD0 and TRDGRA1.
- Output an active high level from the TRDIOB0 output pin at the compare match of registers TRD0 and TRDGRB1.
- Do not use buffer operations (BFC0, BFD0, BFC1, and BFD1).
- Do not use the pulse output forced cutoff input function.
- Do not use A/D triggers.
- Use the timer RD0 interrupt.

Figure 3.1 shows a Block Diagram and Figure 3.2 shows a Timing Diagram. Table 3.1 lists the pins used and their functions.

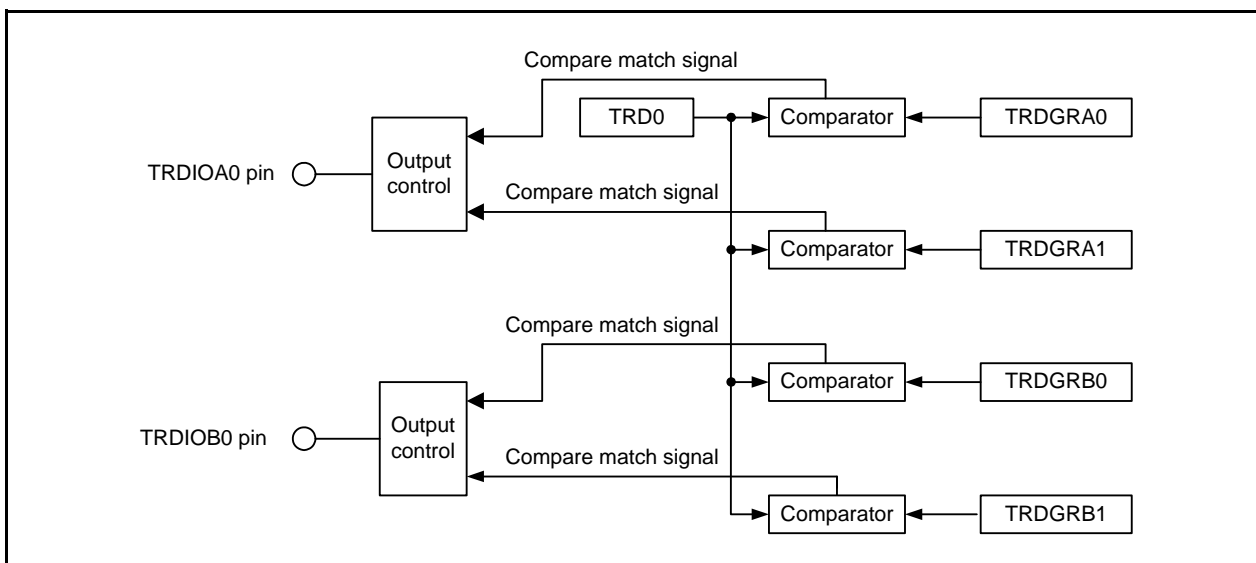

Figure 3.1 Block Diagram

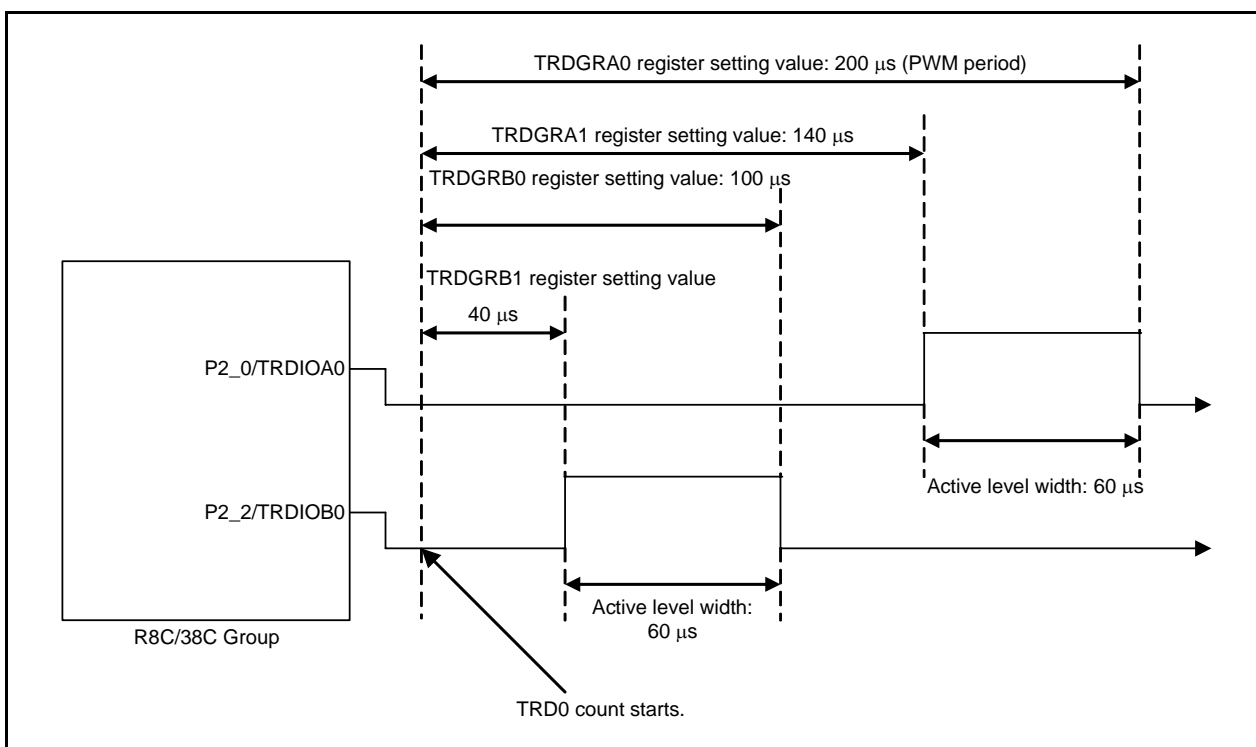

Figure 3.2 Timing Diagram

Table 3.1 Pins and Their Functions

Pin Name	I/O	Function
P2_0/TRDIOA0	Output	PWM output
P2_2/TRDIOB0	Output	PWM output

3.2 Memory

Table 3.2 Memory

Memory	Size	Remarks
ROM	192 bytes	In the r01an0083_src.c module
RAM	0 bytes	In the r01an0083_src.c module
Maximum user stack	10 bytes	
Maximum interrupt stack	18 bytes	

Memory size varies depending on the C compiler version and compile options.

The above applies to the following conditions:

C compiler: M16C Series, R8C Family C Compiler V.5.45 Release 01

Compile option: -c -finfo -dir "\$(CONFIGDIR)" -R8C

4. Software

This section shows the initial setting procedures and values to set the example described in section 3. **Application Example.** Refer to the latest **R8C/38C Group** hardware user's manual for details on individual registers.

The × in the register's Setting Value represents bits not used in this application, blank spaces represent bits that do not change, and the dash represents reserved bits or bits that have nothing assigned.

4.1 Function Tables

Declaration	void mcu_init(void)		
Outline	System clock setting		
Argument	Argument name		Meaning
	None		—
Variable (global)	Variable name		Contents
	None		—
Returned value	Type	Value	Meaning
	None	—	—
Function	Set the system clock (XIN clock).		

Declaration	void timer_rd_init(void)		
Outline	Initial setting of timer RD associated SFRs		
Argument	Argument name		Meaning
	None		—
Variable (global)	Variable name		Contents
	None		—
Returned value	Type	Value	Meaning
	None	—	—
Function	Initialize timer RD associated SFRs to use timer RD in PWM3 mode.		

Declaration	void _timer_rd_ch0(void)		
Outline	Timer RD0 interrupt handling		
Argument	Argument name		Meaning
	None		—
Variable (global)	Variable name		Contents
	None		—
Returned value	Type	Value	Meaning
	None	—	—
Function	Perform timer RD0 interrupt handling.		

4.2 Main Function

- Flowchart

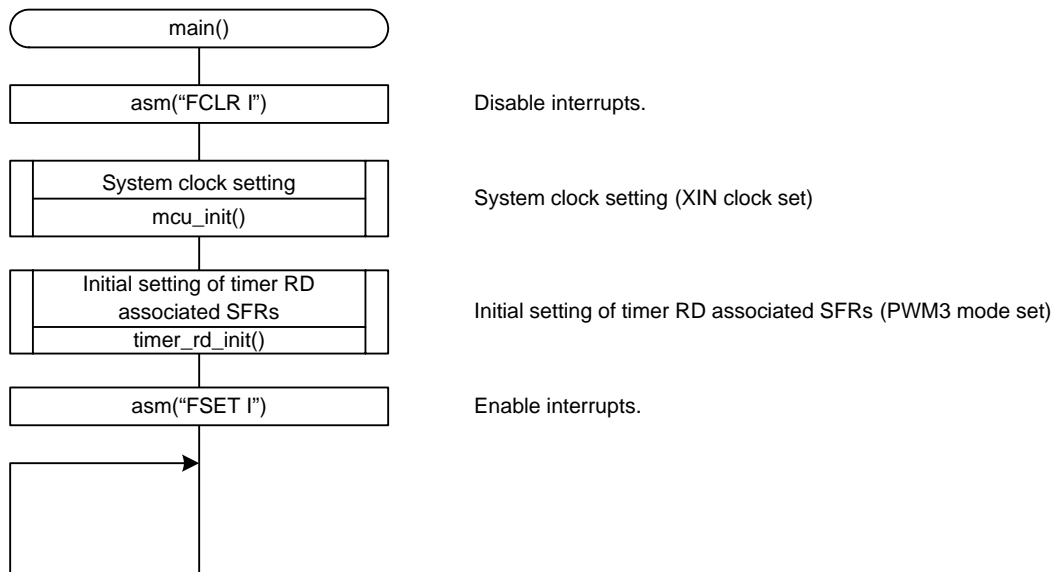

4.3 System Clock Setting

• Flowchart

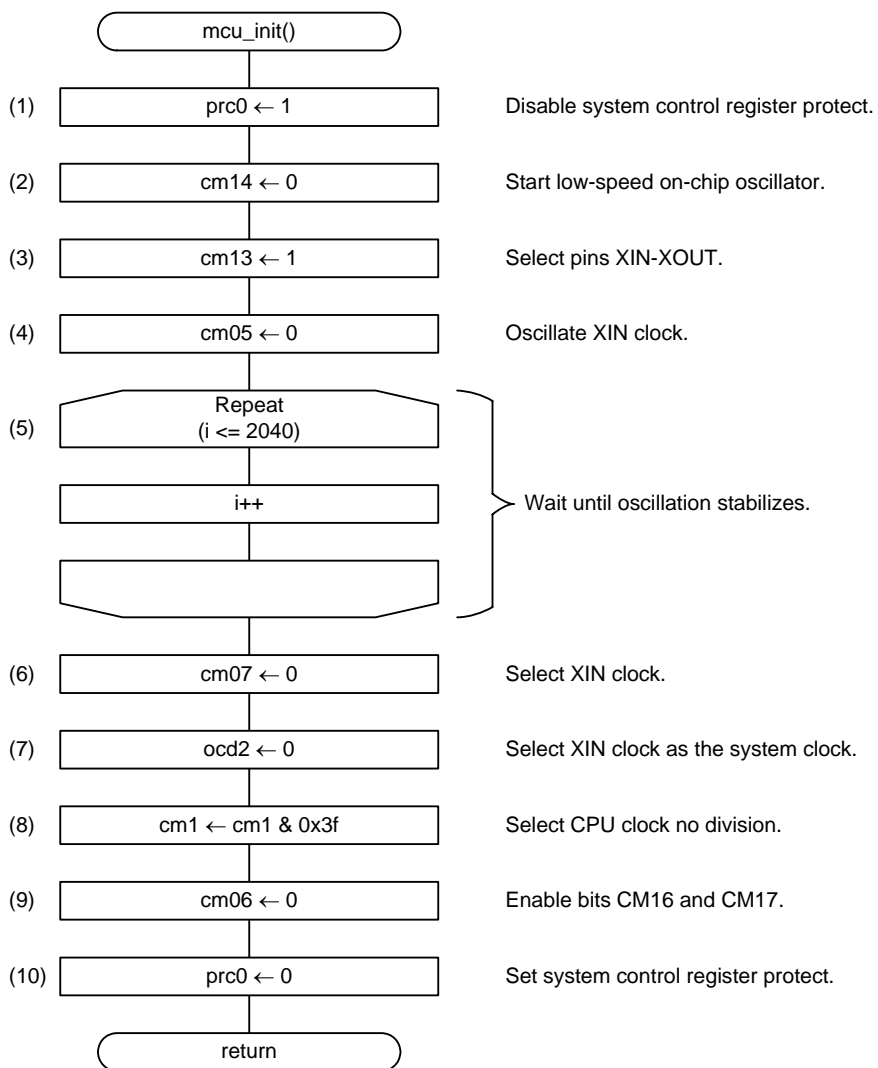

- Register settings

- (1) Enable writing to registers CM0, CM1, CM3, OCD, FRA0, FRA1, FRA2, and FRA3.

Protect Register (PRCR)

Bit	b7	b6	b5	b4	b3	b2	b1	b0
Setting Value	—	—	—	—	x	x	x	1

Bit	Symbol	Bit Name	Function	R/W
b0	PRC0	Protect bit 0	Enables writing to registers CM0, CM1, CM3, OCD, FRA0, FRA1, FRA2, and FRA3. 1: Write enabled	R/W

- (2) Start the low-speed on-chip oscillator.

System Clock Control Register 1 (CM1)

Bit	b7	b6	b5	b4	b3	b2	b1	b0
Setting Value			—	0		x	x	x

Bit	Symbol	Bit Name	Function	R/W
b4	CM14	Low-speed on-chip oscillator stop bit	0: Low-speed on-chip oscillator on	R/W

- (3) Set system clock control register 1.

System Clock Control Register 1 (CM1)

Bit	b7	b6	b5	b4	b3	b2	b1	b0
Setting Value			—		1	x	x	x

Bit	Symbol	Bit Name	Function	R/W
b3	CM13	Port/XIN-XOUT switch bit	1: XIN-XOUT pin	R/W

- (4) Set system clock control register 0.

System Clock Control Register 0 (CM0)

Bit	b7	b6	b5	b4	b3	b2	b1	b0
Setting Value			0	x	x	x	—	—

Bit	Symbol	Bit Name	Function	R/W
b5	CM05	XIN clock (XIN-XOUT) stop bit	0: XIN clock oscillates	R/W

- (5) Wait until oscillation stabilizes.

(6) Select the XIN clock.

System Clock Control Register 0 (CM0)

Bit	b7	b6	b5	b4	b3	b2	b1	b0
Setting Value	0			x	x	x	—	—

Bit	Symbol	Bit Name	Function	R/W
b7	CM07	XIN, XCIN clock select bit	0: XIN clock	R/W

(7) Select the XIN clock as the system clock.

Oscillation Stop Detection Register (OCD)

Bit	b7	b6	b5	b4	b3	b2	b1	b0
Setting Value	—	—	—	—	x	0	x	x

Bit	Symbol	Bit Name	Function	R/W
b2	OCD2	System clock select bit	0: XIN clock selected	R/W

(8) Set system clock register 1.

System Clock Control Register 1 (CM1)

Bit	b7	b6	b5	b4	b3	b2	b1	b0
Setting Value	0	0	—			x	x	x

Bit	Symbol	Bit Name	Function	R/W
b6	CM16	CPU clock division select bit 1	b7 b6 0 0: No division mode	R/W
b7	CM17			R/W

(9) Set system clock control register 0.

System Clock Control Register 0 (CM0)

Bit	b7	b6	b5	b4	b3	b2	b1	b0
Setting Value		0		x	x	x	—	—

Bit	Symbol	Bit Name	Function	R/W
b6	CM06	CPU clock division select bit 0	0: Bits CM16 and CM17 in CM1 register enabled	R/W

(10) Disable writing to registers CM0, CM1, CM3, OCD, FRA0, FRA1, FRA2, and FRA3.

Protect Register (PRCR)

Bit	b7	b6	b5	b4	b3	b2	b1	b0
Setting Value	—	—	—	—	x	x	x	0

Bit	Symbol	Bit Name	Function	R/W
b0	PRC0	Protect bit 0	Enables writing to registers CM0, CM1, CM3, OCD, FRA0, FRA1, FRA2, and FRA3. 0: Write disabled	R/W

4.4 Initial Setting of Timer RD Associated SFRs

• Flowchart

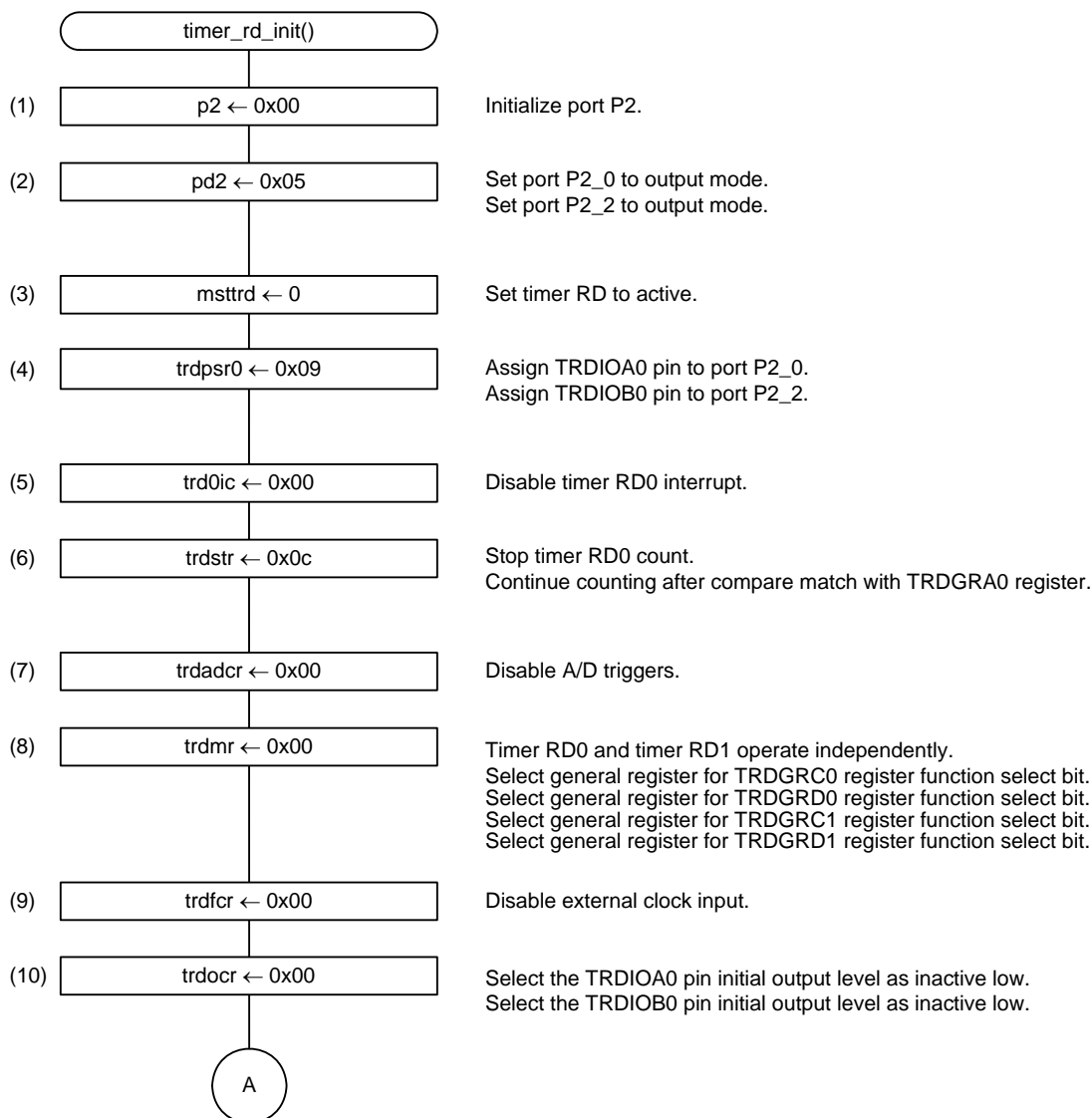

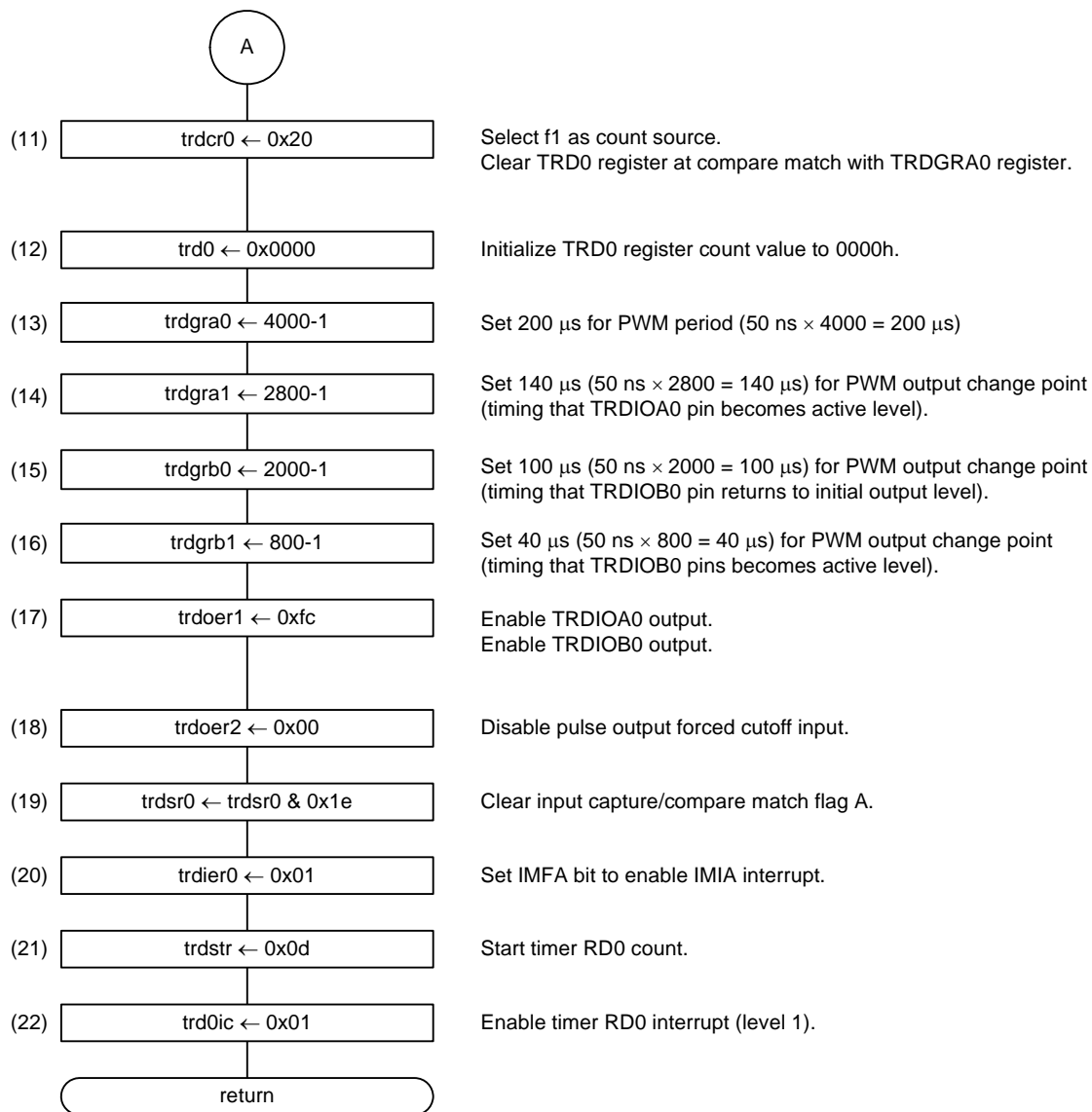

- Register settings

(1) Initialize port P2.

Port P2 Register (P2)

Bit	b7	b6	b5	b4	b3	b2	b1	b0
Setting Value	x	x	x	x	x	0	x	0

Bit	Symbol	Bit Name	Function	R/W
b0	P2_0	Port P2_0 bit	0: "L" level	R/W
b2	P2_2	Port P2_2 bit		R/W

(2) Set ports P2_0 and P2_2 to output mode.

Port P2 Direction Register (PD2)

Bit	b7	b6	b5	b4	b3	b2	b1	b0
Setting Value	x	x	x	x	x	1	x	1

Bit	Symbol	Bit Name	Function	R/W
b0	PD2_0	Port P2_0 direction bit	1: Output mode (functions as an output port)	R/W
b2	PD2_2	Port P2_2 direction bit		R/W

(3) Set timer RD to active.

Module Standby Control Register (MSTCR)

Bit	b7	b6	b5	b4	b3	b2	b1	b0
Setting Value	—	x	x	0	x	—	—	—

Bit	Symbol	Bit Name	Function	R/W
b4	MSTTRD	Timer RD standby bit	0: Active	R/W

(4) Set timer RD pin select register 0.

Timer RD Pin Select Register 0 (TRDPSR0)

Bit	b7	b6	b5	b4	b3	b2	b1	b0
Setting Value	—	x	x	x	1	0	—	1

Bit	Symbol	Bit Name	Function	R/W
b0	TRDIOA0SELO	TRDIOA0/TRDCLK pin select bit	1: P2_0 assigned	R/W
b2	TRDIOB0SELO	TRDIOB0 pin select bit	b3 b2 1 0: P2_2 assigned	R/W
b3	TRDIOB0SEL1			R/W

- (5) Disable the timer RD0 interrupt.

Interrupt Control Register (TRD0IC)

Bit	b7	b6	b5	b4	b3	b2	b1	b0
Setting Value	—	—	—	—		0	0	0

Bit	Symbol	Bit Name	Function	R/W
b0	ILVL0	Interrupt priority level select bit	b2 b1 b0 0 0 0: Level 0 (interrupt disabled)	R/W
b1	ILVL1			R/W
b2	ILVL2			R/W
b3	IR	Interrupt request bit	0: No interrupt requested 1: Interrupt requested	R

- (6) Stop the timer RD0 count and set the timer RD0 count operation.

Timer RD Start Register (TRDSTR)

Bit	b7	b6	b5	b4	b3	b2	b1	b0
Setting Value	—	—	—	—	x	1	x	0

Bit	Symbol	Bit Name	Function	R/W
b0	TSTART0	TRD0 count start flag	0: Count stops	R/W
b2	CSEL0	TRD0 count operation select bit	1: Count continues after the compare match with the TRDGRA0 register	R/W

- (7) Disable A/D triggers.

Timer RD Trigger Control Register (TRDADCR)

Bit	b7	b6	b5	b4	b3	b2	b1	b0
Setting Value	x	x	0	0	x	x	0	0

Bit	Symbol	Bit Name	Function	R/W
b0	ADTRGA0E	A/D trigger A0 enable bit	0: A/D trigger disabled	R/W
b1	ADTRGB0E	A/D trigger B0 enable bit	0: A/D trigger disabled	R/W
b4	ADTRGA1E	A/D trigger A1 enable bit	0: A/D trigger disabled	R/W
b5	ADTRGB1E	A/D trigger B1 enable bit	0: A/D trigger disabled	R/W

- (8) Set the timer RD mode register.

Timer RD Mode Register (TRDMR)

Bit	b7	b6	b5	b4	b3	b2	b1	b0
Setting Value	x	x	0	0	—	—	—	0

Bit	Symbol	Bit Name	Function	R/W
b0	SYNC	Timer RD synchronous bit	Registers TRD0 and TRD1 operate independently	R/W
b4	BFC0	TRDGRC0 register function select bit	0: General register	R/W
b5	BFD0	TRDGRD0 register function select bit	0: General register	R/W
b6	BFC1	TRDGRC1 register function select bit	0: General register	R/W
b7	BFD1	TRDGRD1 register function select bit	0: General register	R/W

(9) Set the timer RD function control register.

Timer RD Function Control Register (TRDFCR)

Bit	b7	b6	b5	b4	b3	b2	b1	b0
Setting Value	0	0	x	x	x	x	0	0

Bit	Symbol	Bit Name	Function	R/W
b0	CMD0	Combination mode select bit	Set to 00b (timer mode, PWM mode, or PWM3 mode) in PWM3 mode.	R/W
b1	CMD1			R/W
b6	STCLK	External clock input select bit	Set this bit to 0 (external clock input disabled) in PWM3 mode.	R/W
b7	PWM3	PWM3 mode select bit	Set this bit to 0 (PWM3 mode) in PWM3 mode.	R/W

(10) Set the timer RD output control register.

Timer RD Output Control Register (TRDOCR)

Bit	b7	b6	b5	b4	b3	b2	b1	b0
Setting Value	x	x	x	x	x	x	0	0

Bit	Symbol	Bit Name	Function	R/W
b0	TOA0	TRDIOA0 output level select bit	0: Active level "H", initial output "L", "H" output at compare match with the TRDGRA1 register, "L" output at compare match with the TRDGRA0 register	R/W
b1	TOB0	TRDIOB0 output level select bit	0: Active level "H", initial output "L", "H" output at compare match with the TRDGRB1 register, "L" output at compare match with the TRDGRB0 register	R/W

(11) Set timer RD control register 0.

Timer RD Control Register 0 (TRDCR0)

Bit	b7	b6	b5	b4	b3	b2	b1	b0
Setting Value	0	0	1	x	x	0	0	0

Bit	Symbol	Bit Name	Function	R/W
b0	TCK0	Count source select bit	b2 b1 b0 0 0 0: f1	R/W
b1	TCK1			R/W
b2	TCK2			R/W
b5	CCLR0	TRD0 counter clear select bit	Set to 001b (the TRD0 register cleared at compare match with TRDGRA0 register) in PWM3 mode.	R/W
b6	CCLR1			R/W
b7	CCLR2			R/W

(12) Initialize timer RD counter 0 to 0000h.

Timer RD Counter 0 (TRD0)

Bit	b7	b6	b5	b4	b3	b2	b1	b0
Setting Value	0	0	0	0	0	0	0	0
Bit	b15	b14	b13	b12	b11	b10	b9	b8
Setting Value	0	0	0	0	0	0	0	0

Bit	Function	Setting Range	R/W
b15-b0	Count a count source. Count operation is incremented. When an overflow occurs, the OVF bit in the TRDSR0 register is set to 1.	0000h to FFFFh	R/W

(13) Set compare value 4000 - 1 (F9Fh) of timer RD counter 0 to timer RD general register A0.

Timer RD General Register A0 (TRDGRA0)

Bit	b7	b6	b5	b4	b3	b2	b1	b0
Setting Value	1	0	0	1	1	1	1	1
Bit	b15	b14	b13	b12	b11	b10	b9	b8
Setting Value	0	0	0	0	1	1	1	1

Bit	Function	R/W
b15-b0	General register. Set the PWM period. Setting range: Value set in TRDGRA1 register or above	R/W

(14) Set compare value 2800 - 1 (AEFh) of timer RD counter 0 to timer RD general register A1.

Timer RD General Register A1 (TRDGRA1)

Bit	b7	b6	b5	b4	b3	b2	b1	b0
Setting Value	1	1	1	0	1	1	1	1
Bit	b15	b14	b13	b12	b11	b10	b9	b8
Setting Value	0	0	0	0	1	0	1	0

Bit	Function	R/W
b15-b0	General register. Set the changing point (the active level timing) of PWM output. Setting range: Value set in TRDGRA0 register or below	R/W

(15) Set compare value 2000 - 1 (7CFh) of timer RD counter 0 to timer RD general register B0.

Timer RD General Register B0 (TRDGRB0)

Bit	b7	b6	b5	b4	b3	b2	b1	b0
Setting Value	1	1	0	0	1	1	1	1
Bit	b15	b14	b13	b12	b11	b10	b9	b8
Setting Value	0	0	0	0	0	1	1	1

Bit	Function	R/W
b15-b0	General register. Set the changing point (the timing that returns to initial output level) of PWM output. Setting range: Value set in TRDGRB1 register or above, Value set in TRDGRA0 register or below	R/W

(16) Set compare value 800 - 1 (31Fh) of timer RD counter 0 to timer RD general register B1.

Timer RD General Register B1 (TRDGRB1)

Bit	b7	b6	b5	b4	b3	b2	b1	b0
Setting Value	0	0	0	1	1	1	1	1
Bit	b15	b14	b13	b12	b11	b10	b9	b8
Setting Value	0	0	0	0	0	0	1	1

Bit	Function	R/W
b15-b0	General register. Set the changing point (active level timing) of PWM output. Setting range: Value set in TRDGRB0 register or below	R/W

(17) Set timer RD output master enable register 1.

Timer RD Output Master Enable Register 1 (TRDOER1)

Bit	b7	b6	b5	b4	b3	b2	b1	b0
Setting Value	1	1	1	1	1	1	0	0

Bit	Symbol	Bit Name	Function	R/W
b0	EA0	TRDIOA0 output disable bit	0: Enable output	R/W
b1	EB0	TRDIOB0 output disable bit	0: Enable output	R/W
b2	EC0	TRDIOC0 output disable bit	Set these bits to 1 (programmable I/O port) in PWM3 mode.	R/W
b3	ED0	TRDIOD0 output disable bit		R/W
b4	EA1	TRDIOA1 output disable bit		R/W
b5	EB1	TRDIOB1 output disable bit		R/W
b6	EC1	TRDIOC1 output disable bit		R/W
b7	ED1	TRDIOD1 output disable bit		R/W

(18) Set to pulse output forced cutoff input disabled.

Timer RD Output Master Enable Register 2 (TRDOER2)

Bit	b7	b6	b5	b4	b3	b2	b1	b0
Setting Value	0	—	—	—	—	—	—	—

Bit	Symbol	Bit Name	Function	R/W
b7	PTO	INT0 of pulse output forced cutoff signal input enabled bit	0: Pulse output forced cutoff input disabled	R/W

(19) Initialize input capture/compare match flag A.

Timer RD Status Register 0 (TRDSR0)

Bit	b7	b6	b5	b4	b3	b2	b1	b0
Setting Value	—	—	—	x	x	x	x	0

Bit	Symbol	Bit Name	Function	R/W
b0	IMFA	Input capture/compare match flag A	[Source for setting this bit to 0] Write 0 after read.	R/W

(20) Set the IMFA bit to enable the IMIA interrupt.

Timer RD Interrupt Enable Register 0 (TRDIER0)

Bit	b7	b6	b5	b4	b3	b2	b1	b0
Setting Value	—	—	—	x	x	x	x	1

Bit	Symbol	Bit Name	Function	R/W
b0	IMIEA	Input capture/compare match interrupt enable bit A	1: Enable interrupt (IMIA) by the IMFA bit	R/W

(21) Start the timer RD0 count.

Timer RD Start Register (TRDSTR)

Bit	b7	b6	b5	b4	b3	b2	b1	b0
Setting Value	—	—	—	—	x		x	1

Bit	Symbol	Bit Name	Function	R/W
b0	TSTART0	TRD0 count start flag	1: Count starts	R/W

(22) Enable the timer RD0 interrupt (level 1).

Interrupt Control Register (TRD0IC)

Bit	b7	b6	b5	b4	b3	b2	b1	b0
Setting Value	—	—	—	—		0	0	1

Bit	Symbol	Bit Name	Function	R/W
b0	ILVL0	Interrupt priority level select bit	b2 b1 b0 0 0 1: Level 1	R/W
b1	ILVL1			R/W
b2	ILVL2			R/W
b3	IR	Interrupt request bit	0: No interrupt requested 1: Interrupt requested	R

4.5 Timer RD0 Interrupt Handling

• Flowchart

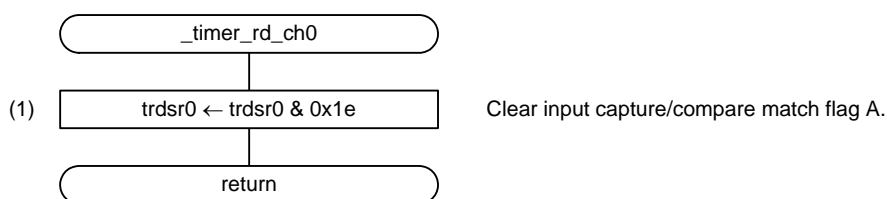

• Register setting

(1) Initialize input capture/compare match flag A.

Timer RD Status Register 0 (TRDSR0)

Bit	b7	b6	b5	b4	b3	b2	b1	b0
Setting Value	—	—	—	x	x	x	x	0

Bit	Symbol	Bit Name	Function	R/W
b0	IMFA	Input capture/compare match flag A	[Source for setting this bit to 0] Write 0 after read.	R/W

5. Sample Program

A sample program can be downloaded from the Renesas Electronics website.

To download, click “Application Notes” in the left-hand side menu of the R8C Family page.

6. Reference Documents

R8C/38C Group User’s Manual: Hardware Rev.1.00

The latest version can be downloaded from the Renesas Electronics website.

Technical Update/Technical News

The latest information can be downloaded from the Renesas Electronics website.

Website and Support

Renesas Electronics website

<http://www.renesas.com/>

Inquiries

<http://www.renesas.com/inquiry>

Revision History	R8C/38C Group Timer RD (PWM3 Mode)
------------------	---------------------------------------

Rev.	Date	Description	
		Page	Summary
1.00	Sep. 27, 2010	—	First edition issued

All trademarks and registered trademarks are the property of their respective owners.

General Precautions in the Handling of MPU/MCU Products

The following usage notes are applicable to all MPU/MCU products from Renesas. For detailed usage notes on the products covered by this manual, refer to the relevant sections of the manual. If the descriptions under General Precautions in the Handling of MPU/MCU Products and in the body of the manual differ from each other, the description in the body of the manual takes precedence.

1. Handling of Unused Pins

Handle unused pins in accord with the directions given under Handling of Unused Pins in the manual.

- The input pins of CMOS products are generally in the high-impedance state. In operation with an unused pin in the open-circuit state, extra electromagnetic noise is induced in the vicinity of LSI, an associated shoot-through current flows internally, and malfunctions occur due to the false recognition of the pin state as an input signal become possible. Unused pins should be handled as described under Handling of Unused Pins in the manual.

2. Processing at Power-on

The state of the product is undefined at the moment when power is supplied.

- The states of internal circuits in the LSI are indeterminate and the states of register settings and pins are undefined at the moment when power is supplied.

In a finished product where the reset signal is applied to the external reset pin, the states of pins are not guaranteed from the moment when power is supplied until the reset process is completed.

In a similar way, the states of pins in a product that is reset by an on-chip power-on reset function are not guaranteed from the moment when power is supplied until the power reaches the level at which resetting has been specified.

3. Prohibition of Access to Reserved Addresses

Access to reserved addresses is prohibited.

- The reserved addresses are provided for the possible future expansion of functions. Do not access these addresses; the correct operation of LSI is not guaranteed if they are accessed.

4. Clock Signals

After applying a reset, only release the reset line after the operating clock signal has become stable. When switching the clock signal during program execution, wait until the target clock signal has stabilized.

- When the clock signal is generated with an external resonator (or from an external oscillator) during a reset, ensure that the reset line is only released after full stabilization of the clock signal. Moreover, when switching to a clock signal produced with an external resonator (or by an external oscillator) while program execution is in progress, wait until the target clock signal is stable.

5. Differences between Products

Before changing from one product to another, i.e. to one with a different part number, confirm that the change will not lead to problems.

- The characteristics of MPU/MCU in the same group but having different part numbers may differ because of the differences in internal memory capacity and layout pattern. When changing to products of different part numbers, implement a system-evaluation test for each of the products.

Notice

- All information included in this document is current as of the date this document is issued. Such information, however, is subject to change without any prior notice. Before purchasing or using any Renesas Electronics products listed herein, please confirm the latest product information with a Renesas Electronics sales office. Also, please pay regular and careful attention to additional and different information to be disclosed by Renesas Electronics such as that disclosed through our website.
- Renesas Electronics does not assume any liability for infringement of patents, copyrights, or other intellectual property rights of third parties by or arising from the use of Renesas Electronics products or technical information described in this document. No license, express, implied or otherwise, is granted hereby under any patents, copyrights or other intellectual property rights of Renesas Electronics or others.
- You should not alter, modify, copy, or otherwise misappropriate any Renesas Electronics product, whether in whole or in part.
- Descriptions of circuits, software and other related information in this document are provided only to illustrate the operation of semiconductor products and application examples. You are fully responsible for the incorporation of these circuits, software, and information in the design of your equipment. Renesas Electronics assumes no responsibility for any losses incurred by you or third parties arising from the use of these circuits, software, or information.
- When exporting the products or technology described in this document, you should comply with the applicable export control laws and regulations and follow the procedures required by such laws and regulations. You should not use Renesas Electronics products or the technology described in this document for any purpose relating to military applications or use by the military, including but not limited to the development of weapons of mass destruction. Renesas Electronics products and technology may not be used for or incorporated into any products or systems whose manufacture, use, or sale is prohibited under any applicable domestic or foreign laws or regulations.
- Renesas Electronics has used reasonable care in preparing the information included in this document, but Renesas Electronics does not warrant that such information is error free. Renesas Electronics assumes no liability whatsoever for any damages incurred by you resulting from errors in or omissions from the information included herein.
- Renesas Electronics products are classified according to the following three quality grades: "Standard", "High Quality", and "Specific". The recommended applications for each Renesas Electronics product depends on the product's quality grade, as indicated below. You must check the quality grade of each Renesas Electronics product before using it in a particular application. You may not use any Renesas Electronics product for any application categorized as "Specific" without the prior written consent of Renesas Electronics. Further, you may not use any Renesas Electronics product for any application for which it is not intended without the prior written consent of Renesas Electronics. Renesas Electronics shall not be in any way liable for any damages or losses incurred by you or third parties arising from the use of any Renesas Electronics product for an application categorized as "Specific" or for which the product is not intended where you have failed to obtain the prior written consent of Renesas Electronics. The quality grade of each Renesas Electronics product is "Standard" unless otherwise expressly specified in a Renesas Electronics data sheets or data books, etc.
"Standard": Computers; office equipment; communications equipment; test and measurement equipment; audio and visual equipment; home electronic appliances; machine tools; personal electronic equipment; and industrial robots.
"High Quality": Transportation equipment (automobiles, trains, ships, etc.); traffic control systems; anti-disaster systems; anti-crime systems; safety equipment; and medical equipment not specifically designed for life support.
"Specific": Aircraft; aerospace equipment; submersible repeaters; nuclear reactor control systems; medical equipment or systems for life support (e.g. artificial life support devices or systems), surgical implantations, or healthcare intervention (e.g. excision, etc.), and any other applications or purposes that pose a direct threat to human life.
- You should use the Renesas Electronics products described in this document within the range specified by Renesas Electronics, especially with respect to the maximum rating, operating supply voltage range, movement power voltage range, heat radiation characteristics, installation and other product characteristics. Renesas Electronics shall have no liability for malfunctions or damages arising out of the use of Renesas Electronics products beyond such specified ranges.
- Although Renesas Electronics endeavors to improve the quality and reliability of its products, semiconductor products have specific characteristics such as the occurrence of failure at a certain rate and malfunctions under certain use conditions. Further, Renesas Electronics products are not subject to radiation resistance design. Please be sure to implement safety measures to guard them against the possibility of physical injury, and injury or damage caused by fire in the event of the failure of a Renesas Electronics product, such as safety design for hardware and software including but not limited to redundancy, fire control and malfunction prevention, appropriate treatment for aging degradation or any other appropriate measures. Because the evaluation of microcomputer software alone is very difficult, please evaluate the safety of the final products or system manufactured by you.
- Please contact a Renesas Electronics sales office for details as to environmental matters such as the environmental compatibility of each Renesas Electronics product. Please use Renesas Electronics products in compliance with all applicable laws and regulations that regulate the inclusion or use of controlled substances, including without limitation, the EU RoHS Directive. Renesas Electronics assumes no liability for damages or losses occurring as a result of your noncompliance with applicable laws and regulations.
- This document may not be reproduced or duplicated, in any form, in whole or in part, without prior written consent of Renesas Electronics.
- Please contact a Renesas Electronics sales office if you have any questions regarding the information contained in this document or Renesas Electronics products, or if you have any other inquiries.
(Note 1) "Renesas Electronics" as used in this document means Renesas Electronics Corporation and also includes its majority-owned subsidiaries.
(Note 2) "Renesas Electronics product(s)" means any product developed or manufactured by or for Renesas Electronics.



SALES OFFICES

Renesas Electronics Corporation

<http://www.renesas.com>

Refer to "<http://www.renesas.com/>" for the latest and detailed information.

Renesas Electronics America Inc.
2880 Scott Boulevard Santa Clara, CA 95050-2554, U.S.A.
Tel: +1-408-588-6000, Fax: +1-408-588-6130

Renesas Electronics Canada Limited
1101 Nicholson Road, Newmarket, Ontario L3Y 9C3, Canada
Tel: +1-905-898-5441, Fax: +1-905-898-3220

Renesas Electronics Europe Limited
Dukes Meadow, Millboard Road, Bourne End, Buckinghamshire, SL8 5FH, U.K
Tel: +44-1628-585-100, Fax: +44-1628-585-900

Renesas Electronics Europe GmbH
Arcadiastrasse 10, 40472 Düsseldorf, Germany
Tel: +49-211-65030, Fax: +49-211-6503-1327

Renesas Electronics (China) Co., Ltd.
7th Floor, Quantum Plaza, No.27 ZhichunLu Haidian District, Beijing 100083, P.R.China
Tel: +86-10-8235-1155, Fax: +86-10-8235-7679

Renesas Electronics (Shanghai) Co., Ltd.
Unit 204, 205, AZIA Center, No.1233 Lujiazui Ring Rd., Pudong District, Shanghai 200120, China
Tel: +86-21-5877-1818, Fax: +86-21-6887-7858 / -7898

Renesas Electronics Hong Kong Limited
Unit 1601-1613, 16/F., Tower 2, Grand Century Place, 193 Prince Edward Road West, Mongkok, Kowloon, Hong Kong
Tel: +852-2886-9318, Fax: +852-2886-9022/9044

Renesas Electronics Taiwan Co., Ltd.
7F, No. 363 Fu Shing North Road Taipei, Taiwan
Tel: +886-2-8175-9600, Fax: +886-2-8175-9670

Renesas Electronics Singapore Pte. Ltd.
1 HarbourFront Avenue, #06-10, Keppel Bay Tower, Singapore 098632
Tel: +65-6213-0200, Fax: +65-6278-8001

Renesas Electronics Malaysia Sdn.Bhd.
Unit 906, Block B, Menara Amcorp, Amcorp Trade Centre, No. 18, Jln Persiaran Barat, 46050 Petaling Jaya, Selangor Darul Ehsan, Malaysia
Tel: +60-3-7955-9390, Fax: +60-3-7955-9510

Renesas Electronics Korea Co., Ltd.
11F, Samik Laviel'or Bldg., 720-2 Yeoksam-Dong, Kangnam-Ku, Seoul 135-080, Korea
Tel: +82-2-558-3737, Fax: +82-2-558-5141