

To our customers,

Old Company Name in Catalogs and Other Documents

On April 1st, 2010, NEC Electronics Corporation merged with Renesas Technology Corporation, and Renesas Electronics Corporation took over all the business of both companies. Therefore, although the old company name remains in this document, it is a valid Renesas Electronics document. We appreciate your understanding.

Renesas Electronics website: <http://www.renesas.com>

April 1st, 2010
Renesas Electronics Corporation

Issued by: Renesas Electronics Corporation (<http://www.renesas.com>)

Send any inquiries to <http://www.renesas.com/inquiry>.

Notice

1. All information included in this document is current as of the date this document is issued. Such information, however, is subject to change without any prior notice. Before purchasing or using any Renesas Electronics products listed herein, please confirm the latest product information with a Renesas Electronics sales office. Also, please pay regular and careful attention to additional and different information to be disclosed by Renesas Electronics such as that disclosed through our website.
2. Renesas Electronics does not assume any liability for infringement of patents, copyrights, or other intellectual property rights of third parties by or arising from the use of Renesas Electronics products or technical information described in this document. No license, express, implied or otherwise, is granted hereby under any patents, copyrights or other intellectual property rights of Renesas Electronics or others.
3. You should not alter, modify, copy, or otherwise misappropriate any Renesas Electronics product, whether in whole or in part.
4. Descriptions of circuits, software and other related information in this document are provided only to illustrate the operation of semiconductor products and application examples. You are fully responsible for the incorporation of these circuits, software, and information in the design of your equipment. Renesas Electronics assumes no responsibility for any losses incurred by you or third parties arising from the use of these circuits, software, or information.
5. When exporting the products or technology described in this document, you should comply with the applicable export control laws and regulations and follow the procedures required by such laws and regulations. You should not use Renesas Electronics products or the technology described in this document for any purpose relating to military applications or use by the military, including but not limited to the development of weapons of mass destruction. Renesas Electronics products and technology may not be used for or incorporated into any products or systems whose manufacture, use, or sale is prohibited under any applicable domestic or foreign laws or regulations.
6. Renesas Electronics has used reasonable care in preparing the information included in this document, but Renesas Electronics does not warrant that such information is error free. Renesas Electronics assumes no liability whatsoever for any damages incurred by you resulting from errors in or omissions from the information included herein.
7. Renesas Electronics products are classified according to the following three quality grades: “Standard”, “High Quality”, and “Specific”. The recommended applications for each Renesas Electronics product depends on the product’s quality grade, as indicated below. You must check the quality grade of each Renesas Electronics product before using it in a particular application. You may not use any Renesas Electronics product for any application categorized as “Specific” without the prior written consent of Renesas Electronics. Further, you may not use any Renesas Electronics product for any application for which it is not intended without the prior written consent of Renesas Electronics. Renesas Electronics shall not be in any way liable for any damages or losses incurred by you or third parties arising from the use of any Renesas Electronics product for an application categorized as “Specific” or for which the product is not intended where you have failed to obtain the prior written consent of Renesas Electronics. The quality grade of each Renesas Electronics product is “Standard” unless otherwise expressly specified in a Renesas Electronics data sheets or data books, etc.
 - “Standard”: Computers; office equipment; communications equipment; test and measurement equipment; audio and visual equipment; home electronic appliances; machine tools; personal electronic equipment; and industrial robots.
 - “High Quality”: Transportation equipment (automobiles, trains, ships, etc.); traffic control systems; anti-disaster systems; anti-crime systems; safety equipment; and medical equipment not specifically designed for life support.
 - “Specific”: Aircraft; aerospace equipment; submersible repeaters; nuclear reactor control systems; medical equipment or systems for life support (e.g. artificial life support devices or systems), surgical implantations, or healthcare intervention (e.g. excision, etc.), and any other applications or purposes that pose a direct threat to human life.
8. You should use the Renesas Electronics products described in this document within the range specified by Renesas Electronics, especially with respect to the maximum rating, operating supply voltage range, movement power voltage range, heat radiation characteristics, installation and other product characteristics. Renesas Electronics shall have no liability for malfunctions or damages arising out of the use of Renesas Electronics products beyond such specified ranges.
9. Although Renesas Electronics endeavors to improve the quality and reliability of its products, semiconductor products have specific characteristics such as the occurrence of failure at a certain rate and malfunctions under certain use conditions. Further, Renesas Electronics products are not subject to radiation resistance design. Please be sure to implement safety measures to guard them against the possibility of physical injury, and injury or damage caused by fire in the event of the failure of a Renesas Electronics product, such as safety design for hardware and software including but not limited to redundancy, fire control and malfunction prevention, appropriate treatment for aging degradation or any other appropriate measures. Because the evaluation of microcomputer software alone is very difficult, please evaluate the safety of the final products or system manufactured by you.
10. Please contact a Renesas Electronics sales office for details as to environmental matters such as the environmental compatibility of each Renesas Electronics product. Please use Renesas Electronics products in compliance with all applicable laws and regulations that regulate the inclusion or use of controlled substances, including without limitation, the EU RoHS Directive. Renesas Electronics assumes no liability for damages or losses occurring as a result of your noncompliance with applicable laws and regulations.
11. This document may not be reproduced or duplicated, in any form, in whole or in part, without prior written consent of Renesas Electronics.
12. Please contact a Renesas Electronics sales office if you have any questions regarding the information contained in this document or Renesas Electronics products, or if you have any other inquiries.

(Note 1) “Renesas Electronics” as used in this document means Renesas Electronics Corporation and also includes its majority-owned subsidiaries.

(Note 2) “Renesas Electronics product(s)” means any product developed or manufactured by or for Renesas Electronics.

32176 Group

Application of Timer TIO (PWM output Mode)

1. Overview

The following article shows sample program of 32176 group using timer TIO.

2. Introduction

The sample task described here uses the following microcomputer, under the respective conditions.

- Microcomputer: 32176 Group (M32176FnVFP, M32176FnTFP)
- Operating frequency: 20 to 40MHz (The sample program is compiled assuming a frequency of 40 MHz.)
- Operating Board: Starter kit for 32176 Group

3. Explanation of an applied technology

3.1 Outline of Multijunction Timers

The multijunction timers (abbreviated MJT) have input event buses and output event buses. Therefore, in addition to be used as a single unit, the timers can be internally connected to each other. This capability allows for highly flexible timer configuration, making it possible to meet various applications needs. It is because the timers are connected to internal event bus at multiple points that they are called the “multijunction” timers.

MJT is detailed in 32176 Group User's Manual.

4. PWM Output mode Sample Program

4.1 Outline of the sample program

The sample program here starts the timer to output PWM waveforms by specifying the PWM cycle and duty with arguments by using TIO0 is output to external terminal TO11. Interrupt by underflow is not used here.

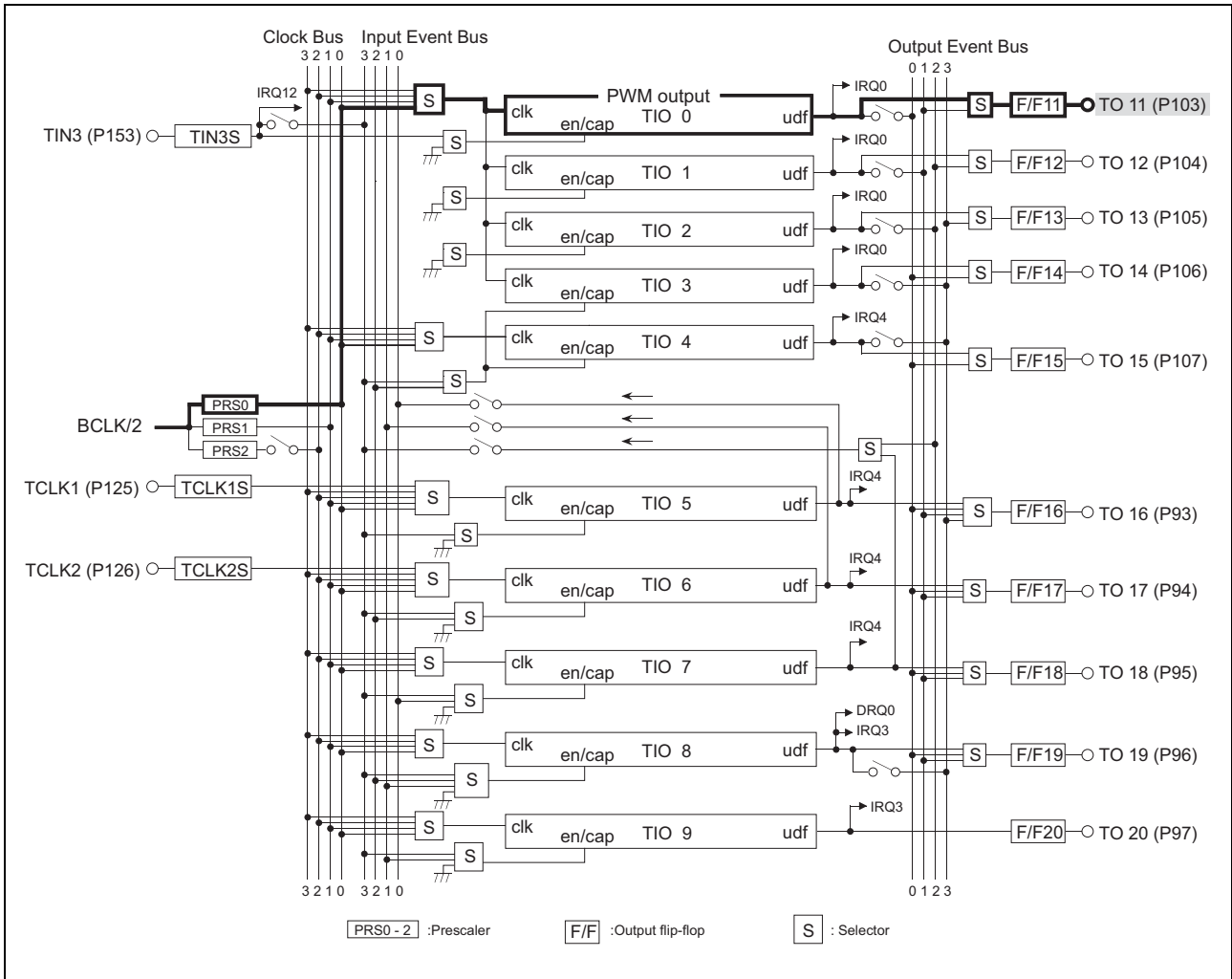

Figure 4.1.1 Configuration of TIO PWM Output Timer

4.2 Processing procedure

The basic processing flow of a timer setup is shown in Figure 4.2.1.

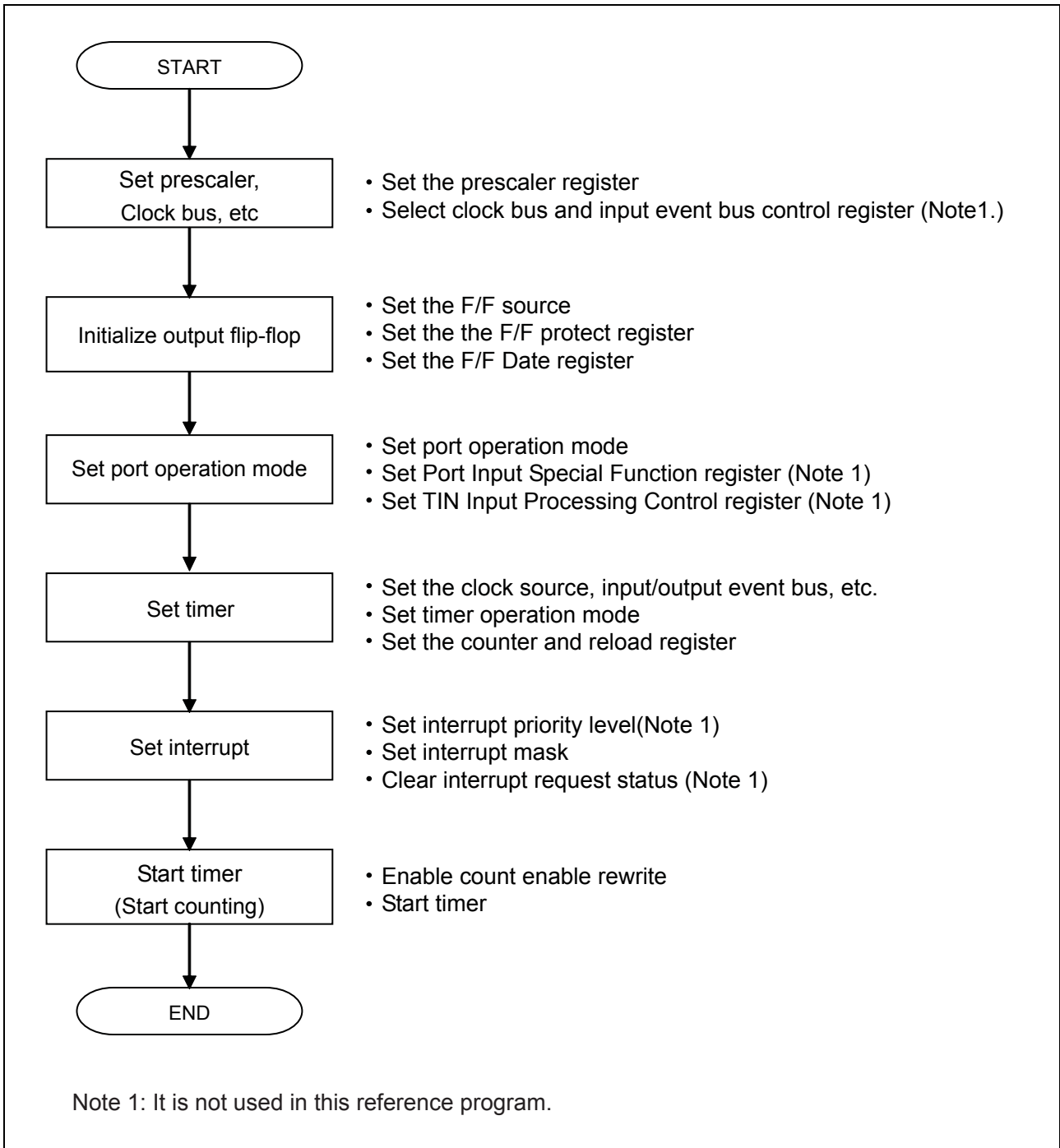

Figure 4.2.1 Basic Timer Setup Flow

4.3 Description of a reference program

Note. The registers used are indicated as (register name: bit name)

4.3.1 Timer initialization function (timer_init())

- (1) Set the prescaler's divide-by value
 - Set prescaler register 0 as “the prescaler's divide-by value-1”. (PRS0)

4.3.2 Various initialization function (init_func())

- (1) Call the timer initialization function

4.3.3 Main function (main())

- (1) Call the interrupt disable function
- (2) Call the various initialization function
- (3) Call the TIO0 PWM output mode Initial setting function
- (4) Call the interrupt enable function
- (5) Call the TIO0 PWM output start function
(PWM cycle and duty value are given)
- (6) Infinite loop waiting for Interrupt

4.3.4 TIO0 PWM output mode initial setting function (TIO0_PWM_init())

(1) Initializing the timer output pin

- Select TIO0 output in F/F11 source selection. (FFS0: FF11)
- Enable writing to the F/F11 output bit. (FFP0: FP11)
- Set the F/F11 output initial value to “0”. (FFD0: FD11)
- Set P103 operation mode bit of P10 Operation Mode Register to TO11. (P10MOD: P103MOD)

(2) Setting timer TIO0

- Select clock bus 0 for the clock source. (TIO03CR1: TIO03CKS)
- Set TIO0 to PWM output mode. (TIO03CR0: TIO0M)
- Disable TIO0 interrupt. (TIOIR0: TIOIM0)

4.3.5 TIO0 PWM output start function (TIO0_PWM_out())

(1) Execution judgment

- If the PWM cycle is “0”, terminate abnormally.

(2) Calculating output time

- Calculate the high-level pulse width from the PWM cycle and duty.
- Call the disable interrupt function.

(3) Processing when duty is “0” or high-level pulse is “0” (Low-level is outputted)

- Enable writing to TIO0 count enable bit. (TIOPRO: TIO0PRO)
- Stop TIO0 count. (TIOCEN: TIO0CEN)
- Set P103 data bit in P10 Data Register to “0”. (P10DATA: P103DT)
- Set P103 direction bit in P10 Direction Register to output mode. (P10DIR: P103 DIR)
- Set P103 operation mode bit in P10 Operation Mode Register to input/output port. (P10MOD: P103MOD)

(4) Processing when duty is more than H'100 or high-level pulse is more than PWM cycle (High-level is outputted)

- Enable writing to TIO0 count enable bit. (TIOPRO: TIO0PRO)
- Stop TIO0 count. (TIOCEN: TIO0CEN)
- Set P103 data bit in P10 Data Register to “0”. (P10DATA: P103DT)
- Set P103 direction bit in P10 Direction Register to output mode. (P10DIR: P103 DIR)
- Set P103 operation mode bit in P10 Operation Mode Register to input/output port. (P10MOD: P103MOD)

(5) Processing for other condition

- Set the high-level and the low-level pulse widths in reload 0 and 1 registers, respectively.
- When the timer is not operating, perform the following processing.
 - 1) Enable writing to the F/F11 output bit. (FFP0: FP11)
 - 2) Set the F/F11 output initial value to “0”. (FFD0: FD11)
 - 3) Enable writing to TIO0 count enable bit. (TIOPRO: TIO0PRO)
 - 4) Start TIO0 count. (TIOCEN: TIO0CEN)
 - 5) Wait until F/F11 output goes high-level. (Delay by count clock).
- Set P103 operation mode bit of P10 Operation Mode Register to TO11. (P10MOD: P103MOD)

(6) Call the enable interrupt function

Note. When set Direction Register to output before setting port Data Register, undefined value is outputted until finish writing to Data Register.

4.4 Sample Programming Code

The sample program of TIO0 PWM output Mode is shown below.

The sample program here starts the timer to output PWM waveforms by specifying the PWM cycle and duty with arguments. The reload register set values are calculated from the PWM cycle and duty in the program.

Note that the sample program below requires the SFR definition file. The latest SFR definition file can be downloaded from Renesas Technology website. When using the SFR definitions file, adjust the path setting to match the operating computer environment.

4.4.1 TIO0_pwm_main.c

```

1  /*"FILE COMMENT"*****
2  *      M32R C Programming          Rev. 1.01
3  *      < Sample Program for 32176 >
4  *      < TIO0 PWM output (main routine) >
5  *
6  *      Copyright (c) 2004 Renesas Technology Corporation
7  *      All Rights Reserved
8  *      *****/
9
10 /******/
11 /*      Include file                      */
12 /******/
13
14 #include          "..\inc\sfr32176_pragma.h"
15
16 /******/
17 /*      Function prototype declaration    */
18 /******/
19
20 void          main(void);          /* Main function */
21 void          init_func(void);     /* Initial setup function */
22 void          timer_init(void);    /* Timer initialization */
23
24 /******/
25 /*      Definition of external reference  */
26 /******/
27
28 extern void    DisInt( void );     /* Interrupt disable function */
29 extern void    EnInt( void );     /* Interrupt enable function */
30
31 extern void    TIO0_PWM_init( void ); /* Initialize TIO0 PWM output mode */
32 extern ULONG   TIO0_PWM_out( USHORT cycle, USHORT duty ); /* Start TIO0 PWM output */
33
34 /*"FUNC COMMENT"*****
35 * Function name: timer_init()
36 *-----
37 * Description  : Initialize timer
38 *-----
39 * Argument    : -
40 *-----
41 * Returns     : -
42 *-----
43 * Notes      :
44 *"FUNC COMMENT END"*****/
45 void timer_init(void)
46 {
47     PRS0 = ( 100 - 1);          /* Set prescaler(10us@10MHz) */
48 }
49
50 /*"FUNC COMMENT"*****
51 * Function name: init_func()
52 *-----
53 * Description  : Call various initialization functions
54 *-----
55 * Argument    : -
56 *-----
57 * Returns     : -
58 *-----
59 * Notes      :
60 *"FUNC COMMENT END"*****/
61 void init_func(void)
62 {
63     timer_init();              /* Initialize those related to timer */
64 }
65
66 /*"FUNC COMMENT"*****
67 * Function name: main()
68 *-----
69 * Description  : While using TIO0 in PWM output mode, this program outputs a PWM waveform from the TIO1 pin
70 *               : with a 2ms period (when the source clock frequency = 10 MHz) and a 10/256 high duty cycle.

```

```

71  *-----
72  * Argument      : -
73  *-----
74  * Returns      : -
75  *-----
76  * Notes        :
77  *"FUNC COMMENT END"*****
78  void main(void)
79  {
80      DisInt();                /* Disable interrupt */
81
82      init_func();
83
84      TIO0_PWM_init();         /* Initialize TIO0 PWM output mode */
85
86      EnInt();                /* Enable interrupt */
87
88      TIO0_PWM_out( (USHORT)200, (USHORT)16); /* Start TIO0 PWM output */
89
90      while( 1 ){
91          ;
92      }
93  }

```

4.4.2 TIO0_pwm.c

```

1  /*"FILE COMMENT"*****
2  *      M32R C Programming          Rev. 1.01
3  *      < Sample Program for 32176 >
4  *      < TIO0 PWM output mode >
5  *
6  *      Copyright (c) 2004 Renesas Technology Corporation
7  *      All Rights Reserved
8  *****/
9
10 *****/
11 /*      Include file                      */
12 *****/
13
14 #include          "..\inc\sfr32176_pragma.h"
15
16 *****/
17 /*      Definition of external reference  */
18 *****/
19
20 extern void      DisInt( void );          /* Interrupt disable function */
21 extern void      EnInt( void );          /* Interrupt enable function */
22
23 *****/
24 /*      Function prototype declaration    */
25 *****/
26
27 void            TIO0_PWM_init( void );    /* Initialize TIO0 PWM output mode */
28 ULONG          TIO0_PWM_out( USHORT cycle, USHORT duty ); /* Start TIO0 PWM output */
29
30 *****/
31 /*      Define macro                      */
32 *****/
33
34 #define OK      1ul
35 #define NG      0ul
36
37 /** PWM(TIO0) **/
38
39                                     /* 0123 4567          */
40 #define TIO03_ClkSrc      0x00          /* 0000 0000B          */
41                                     /* |||| |++----- Select clock bus 0          */
42                                     /* ++++ ++----- don't care          */
43
44                                     /* 0123 4567 89AB CDEF          */
45 #define TIO0_MASK        0x000fu      /* 0000 0000 0000 1111B          */
46 #define TIO0_PWM         0x0003u      /* 0000 0000 0000 0011B          */
47                                     /*          |+++ Set TIO0 PWM mode          */
48                                     /*          +---- TIO0 enable: unselected          */
49
50                                     /* 0123 4567 89AB CDEF          */
51 #define FF11_TIO0M      0x0100u      /* 0000 0001 0000 0000B          */
*/
52                                     /*          +----- FF11 source : TIO0 unselected          */
53
54 /*"FUNC COMMENT"*****
55 * Function name: TIO0_PWM_init()
56 *-----
57 * Description : Initial settings necessary to drive TIO0 in PWM mode
58 *              : - While driving TIO0 in PWM mode, this function outputs PWM waveform from T011
59 *              : - The count source used for this operation is clock bus 0
60 *-----
61 * Argument   : -
62 *-----
63 * Returns    : -
64 *-----
65 * Notes      : The prescaler, clock bus, etc. are set separately from the above
66 *              : Must be executed while interrupts are disabled
67 *"FUNC COMMENT END"*****/
68 void TIO0_PWM_init( void )
69 {
70     UCHAR temp;
71     USHORT temp16;
72
73 /** Initializing P103 (T011) output (low-level output) **/
74
75     FFS0 &= ~FF11_TIO0M;          /* FF11 source : TIO0 selected */
76
77     FFP0 = (~FP11) & 0xFFFFu;    /* Enable F/Fl1 rewrite */
78     FFD0 = 0x0000;              /* F/Fl1 low (0) output (inverted to high during timer
operation) */
79     P10MOD |= 0x10u;            /* Select T011 (TIO0 output) for output */
80
81 /** PWM setting (TIO0) **/
82

```

```

83     TIO03CR1 = TIO03_ClkSrc;                /* Select TIO0 clock source */
84
85     templ6 = TIO03CR0;
86     TIO03CR0 = ( templ6 & ~TIO0_MASK) | TIO0_PWM;    /* Set TIO0 PWM */
87     temp = TIOIR0;
88     temp |= ( TIOIS3 | TIOIS2 | TIOIS1) | TIOIM0;    /* Disable TIO0 interrupt */
89     TIOIR0 = temp;
90 }
91
92 /*"FUNC COMMENT"*****
93 * Function name: TIO0_PWM_out()
94 *-----
95 * Description  : Drive TIO1 in PWM mode
96 *-----
97 * Argument    : unsigned short cycle  PWM period
98 *              : unsigned short duty   High duty (0~100%:0x0000~0x0100)
99 *-----
100 * Returns    : Terminated normally      1
101 *              : Terminated abnormally   0
102 *              : - PWM period = 0
103 *-----
104 * Notes      : PWM periodFor 0/100% duty cycle, OFF/ON processing is performed in port mode.
105 *"FUNC COMMENT END"*****
106 ULONG TIO0_PWM_out( USHORT cycle, USHORT duty)
107 {
108     ULONG Hwidth;
109     ULONG ret_c;
110
111     ret_c = OK;
112
113     if( cycle == 0) {                          /* Determine PWM period */
114         ret_c = NG;
115     }
116     else{
117
118     /** Calculating high-level output time ***/
119
120         Hwidth = (ULONG)duty * cycle;
121         Hwidth >>= 8;
122
123         DisInt();                               /* Disable TIO0 interrupt */
124
125     /** duty 0% ***/
126
127         if(( duty == 0) ||
128            ( Hwidth == 0u)) {
129             TIOPRO = (~TIO0PRO) & 0xFFFFu;    /* Enable TIO0 enable protect rewrite */
130             TIOCEN = 0x0000;                  /* Stop TIO0 count (PWM stop) */
131             P1ODATA &= ~0x10u;                /* P103 low(0) output */
132             P1ODIR |= 0x10u;                  /* P103 output */
133             P1OMOD &= ~0x10u;                /* Disable TO11 (TIO0 output) against output .. Port P103
output selected */
134         }
135
136     /** duty 100% ***/
137
138         else if(( duty >= 0x100) ||
139                ( Hwidth >= cycle)) {
140             TIOPRO = (~TIO0PRO) & 0xFFFFu;    /* Enable TIO0 enable protect rewrite */
141             TIOCEN = 0x0000;                  /* Stop TIO0 count (PWM stop) */
142             P1ODATA |= 0x10u;                /* P103 High(0) output */
143             P1ODIR |= 0x10u;                  /* P103 output */
144             P1OMOD &= ~0x10u;                /* Disable TO11 (TIO0 output) against output .. Port P103
output selected */
145         }
146
147     /** PWM output ***/
148
149         else {
150             TIOORL1 = cycle - (USHORT)Hwidth - 1;
151             TIOORL0 = (USHORT)Hwidth - 1;
152             if(( TIOCEN & TIOOCEN) == 0u) {    /* Start output from 0% or 100% state */
153                 FFP0 = (~FP11) & 0xFFFFu;    /* Enable F/F11 rewrite */
154                 FFD0 = 0x0000;                /* F/F11 low (0) output (inverted to high during
timer operation) */
155                 TIOPRO = (~TIO0PRO) & 0xFFFFu; /* Enable TIO0 enable protect rewrite */
156                 TIOCEN = 0xffff;              /* Start TIO0 count (PWM start) */
157
158             /** Preventing glitch generated by a prescaler equivalent delay ***/
159
160                 while(( FFD0 & FD11) == 0u){ /* Start timer and wait until F/F11 goes high
*/
161                     ;
162                 }
163             }
164         }
165     }
166 }

```

```
166         }
167         P10MOD |= 0x10u;           /* Select T011 (TIO0 output) for output */
168     }
169     EnInt();                       /* Enable interrupt */
170 }
171
172 return( ret_c );
173 }
```

4.5 Timing of operation

Timing of operation in this reference program is shown below.
(In the program, it is considering as cycle=200, duty= 16)

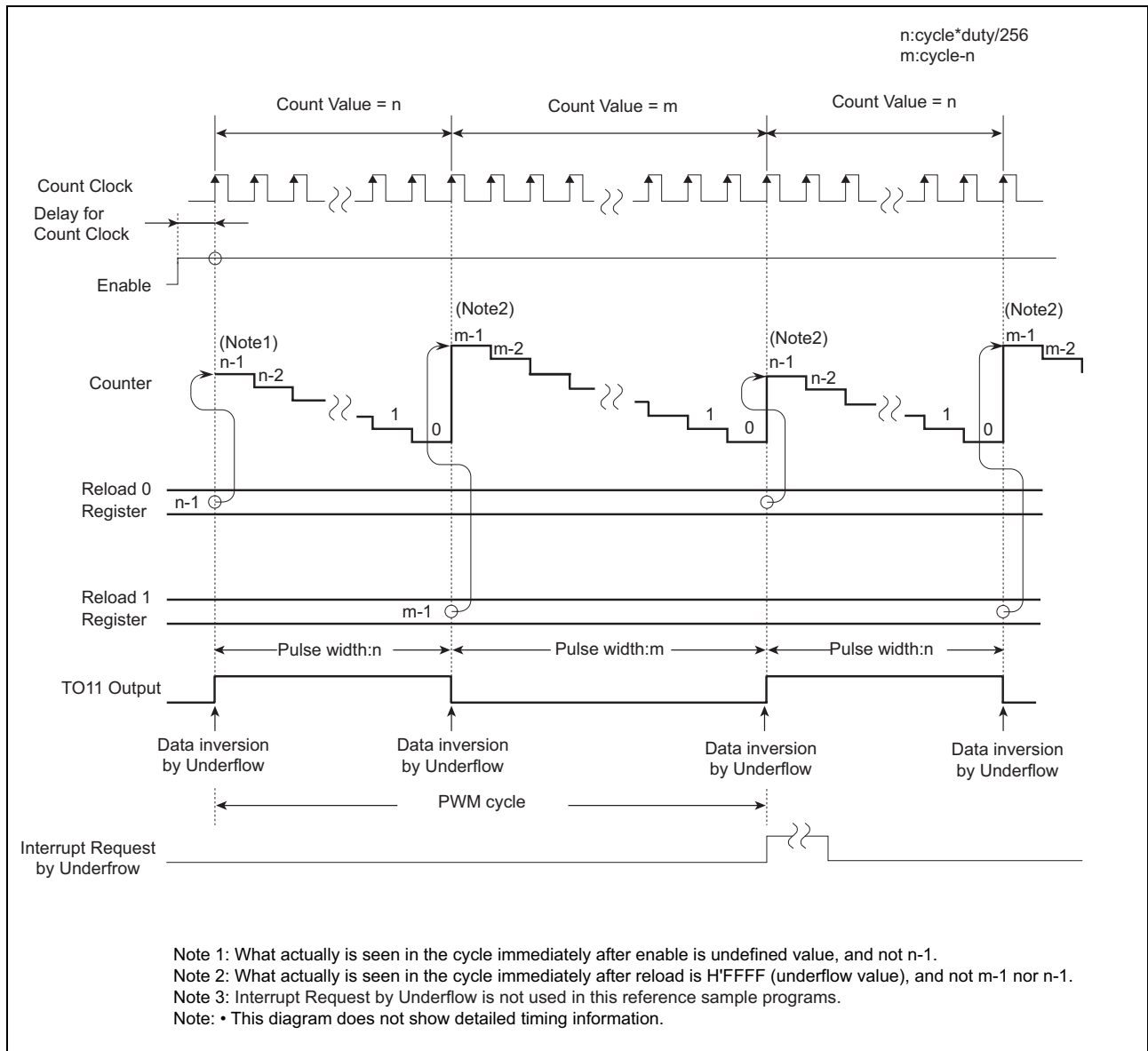

Figure 4.5.1 Timing Diagram for TIO PWM output mode

5. Reference of Document

- 32176 Group User's Manual Rev.1.01
- M32R Family Software Manual Rev.1.20
- M3T-CC32R V.4.30 User's Manual (Compiler)
- M3T-AS32R V.4.30 User's Manual (Assembler)

(Please get the latest one from Renesas Technology Corp. website.)

6. Website and Support Center

- Renesas Technology Corp. website
<http://www.renesas.com/>
- Customer Support Center for all Products and Technical Support Center for M32R Family
Customer Support Center: csc@renesas.com

Revision Record

Rev.	Date	Description	
		Page	Summary
1.00	Jan 11, 2006	-	First Edition issued

Keep safety first in your circuit designs!

1. Renesas Technology Corp. puts the maximum effort into making semiconductor products better and more reliable, but there is always the possibility that trouble may occur with them. Trouble with semiconductors may lead to personal injury, fire or property damage. Remember to give due consideration to safety when making your circuit designs, with appropriate measures such as (i) placement of substitutive, auxiliary circuits, (ii) use of non-flammable material or (iii) prevention against any malfunction or mishap.

Notes regarding these materials

1. These materials are intended as a reference to assist our customers in the selection of the Renesas Technology Corp. product best suited to the customer's application; they do not convey any license under any intellectual property rights, or any other rights, belonging to Renesas Technology Corp. or a third party.
2. Renesas Technology Corp. assumes no responsibility for any damage, or infringement of any third-party's rights, originating in the use of any product data, diagrams, charts, programs, algorithms, or circuit application examples contained in these materials.
3. All information contained in these materials, including product data, diagrams, charts, programs and algorithms represents information on products at the time of publication of these materials, and are subject to change by Renesas Technology Corp. without notice due to product improvements or other reasons. It is therefore recommended that customers contact Renesas Technology Corp. or an authorized Renesas Technology Corp. product distributor for the latest product information before purchasing a product listed herein.
The information described here may contain technical inaccuracies or typographical errors. Renesas Technology Corp. assumes no responsibility for any damage, liability, or other loss rising from these inaccuracies or errors.
Please also pay attention to information published by Renesas Technology Corp. by various means, including the Renesas Technology Corp. Semiconductor home page (<http://www.renesas.com>).
4. When using any or all of the information contained in these materials, including product data, diagrams, charts, programs, and algorithms, please be sure to evaluate all information as a total system before making a final decision on the applicability of the information and products. Renesas Technology Corp. assumes no responsibility for any damage, liability or other loss resulting from the information contained herein.
5. Renesas Technology Corp. semiconductors are not designed or manufactured for use in a device or system that is used under circumstances in which human life is potentially at stake. Please contact Renesas Technology Corp. or an authorized Renesas Technology Corp. product distributor when considering the use of a product contained herein for any specific purposes, such as apparatus or systems for transportation, vehicular, medical, aerospace, nuclear, or undersea repeater use.
6. The prior written approval of Renesas Technology Corp. is necessary to reprint or reproduce in whole or in part these materials.
7. If these products or technologies are subject to the Japanese export control restrictions, they must be exported under a license from the Japanese government and cannot be imported into a country other than the approved destination.
Any diversion or reexport contrary to the export control laws and regulations of Japan and/or the country of destination is prohibited.
8. Please contact Renesas Technology Corp. for further details on these materials or the products contained therein.