

1. Abstract

This document describes the setting procedure to use the A/D converter in one-shot mode with a software trigger.

2. Introduction

The application example described in this document applies to the following microcomputer (MCU):

- MCU: M16C/64A Group

This application note can be used with other M16C Family MCUs which have the same special function registers (SFRs) as the above group. Check the manual for any modifications to functions. Careful evaluation is recommended before using the sample code described in this application note.

3. Operation in One-Shot Mode

This section describes operation when using the A/D converter in one-shot mode with a software trigger.

- (1) When the ADST bit in the ADCON0 register is set to 1 (A/D conversion start), A/D conversion starts.
- (2) After completing A/D conversion, the value in the successive conversion register (conversion result) is transferred to the ADi register (i = 0 to 7). At the same time, the IR bit in the ADIC register becomes 1 (interrupt requested). The ADST bit becomes 0 (A/D conversion stop) and A/D conversion stops.

Figure 3.1 shows the Operation Timing in One-Shot Mode.

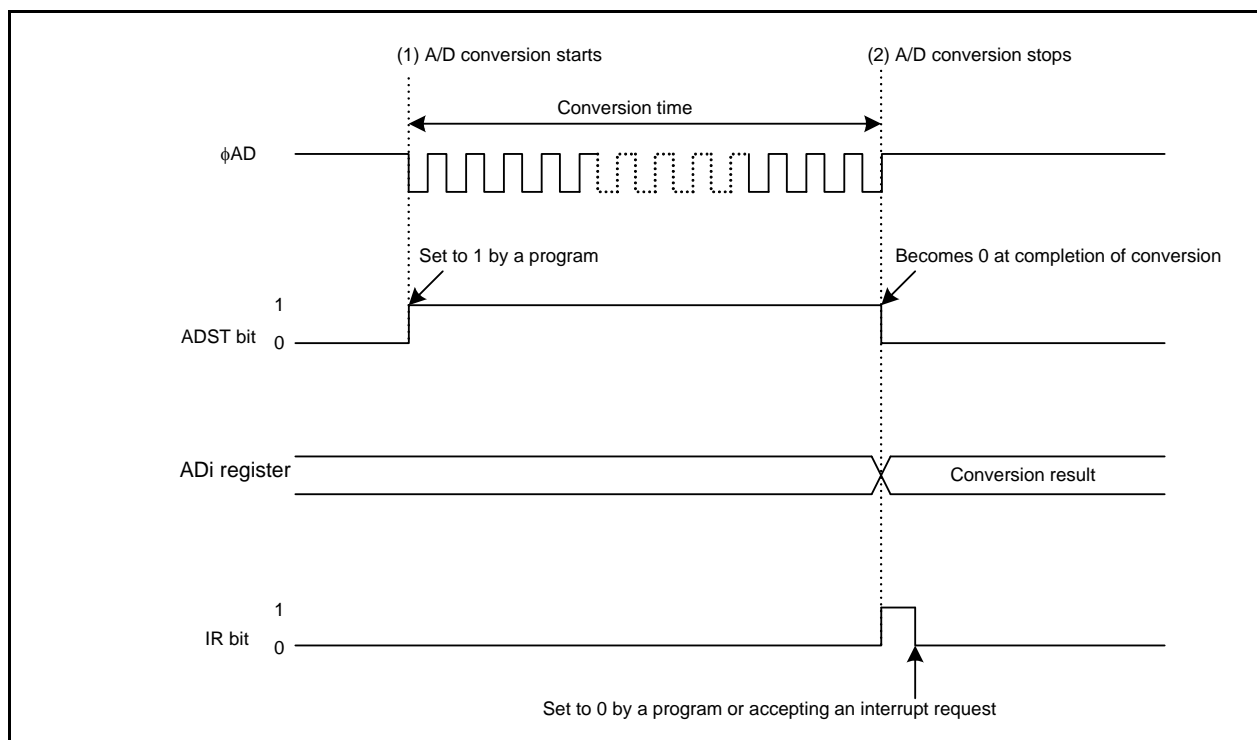

Figure 3.1 Operation Timing in One-Shot Mode

4. A/D Conversion Time

This section describes how to calculate A/D conversion time.

4.1 A/D Conversion Cycle

Table 4.1 shows Cycles of A/D Conversion Item. A/D conversion time is described below.

Start processing time depends on which ϕ_{AD} is selected.

A/D conversion starts after the start processing time elapses by setting the ADST bit in the ADCON0 register to 1 (A/D conversion start). When reading the ADST bit before starting A/D conversion, 0 (A/D conversion stop) is read.

In one-shot mode, the ADST bit becomes 0 at the end processing time and the last A/D conversion result is stored in the ADi register ($i = 0$ to 7).

- One-shot mode:

Start processing time + A/D conversion execution time + end processing time

Table 4.1 Cycles of A/D Conversion Item

A/D Conversion Item		Number of Cycles
Start processing time	$\phi_{AD} = f_{AD}$	1 to 2 cycles of f_{AD}
	$\phi_{AD} = f_{AD}$ divided by 2	2 to 3 cycles of f_{AD}
	$\phi_{AD} = f_{AD}$ divided by 3	3 to 4 cycles of f_{AD}
	$\phi_{AD} = f_{AD}$ divided by 4	3 to 4 cycles of f_{AD}
	$\phi_{AD} = f_{AD}$ divided by 6	4 to 5 cycles of f_{AD}
	$\phi_{AD} = f_{AD}$ divided by 12	7 to 8 cycles of f_{AD}
A/D conversion execution time	Open-circuit detection disabled	40 cycles of ϕ_{AD}
	Open-circuit detection enabled	42 cycles of ϕ_{AD}
End processing time		2 to 3 cycles of f_{AD}

4.2 Detecting Completion of A/D Conversion

In one-shot mode, use the IR bit in the ADIC register to detect completion of A/D conversion. When not using an interrupt, set the IR bit to 0 by a program after detection.

When 1 is written to the ADST bit in the ADCON0 register, the ADST bit becomes 1 (A/D conversion start) after start processing time elapses (see Table 4.1 “Cycles of A/D Conversion Item”). Therefore when reading the ADST bit immediately after writing 1, 0 (A/D conversion stop) may be read.

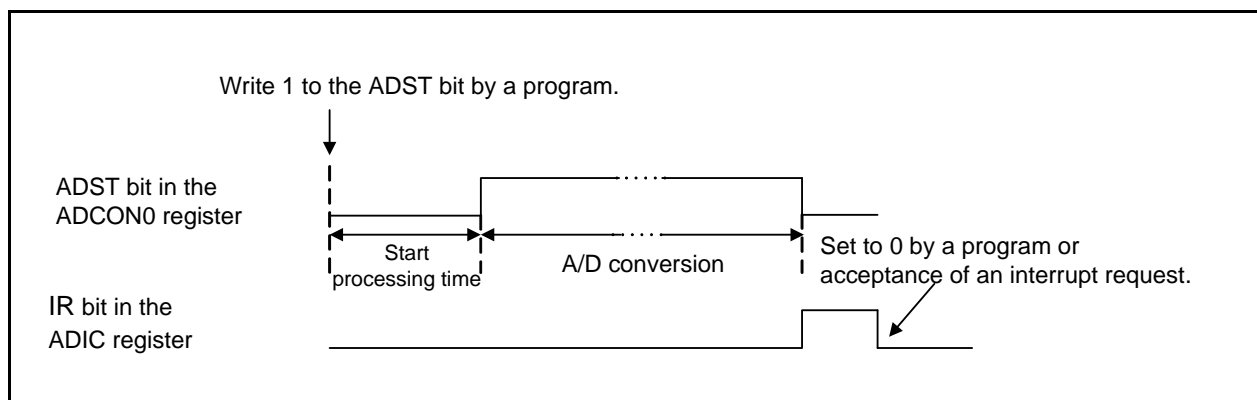

Figure 4.1 ADST Bit Operation

4.3 A/D Operation Clock Frequencies

Table 4.2 lists the A/D Operation Clock Frequencies.

Table 4.2 A/D Operation Clock Frequencies (1)

$V_{CC1} = AV_{CC} = 3.0 \text{ to } 5.5 \text{ V} \geq V_{CC2} \geq V_{REF}$, $V_{SS} = AV_{SS} = 0 \text{ V}$ at $T_{opr} = -20^\circ\text{C to } 85^\circ\text{C}/-40^\circ\text{C to } 85^\circ\text{C}$ unless otherwise specified.

Symbol	Parameter		Measuring Condition	Standard			Unit
				Min.	Typ.	Max.	
ϕ_{AD}	A/D operating clock frequency	AN0 to AN7 input, ANEX0 to ANEX1 input	$4.0 \text{ V} \leq V_{CC1} \leq 5.5 \text{ V}$	2		25	MHz
			$3.2 \text{ V} \leq V_{CC1} \leq 4.0 \text{ V}$	2		16	MHz
			$3.0 \text{ V} \leq V_{CC1} \leq 3.2 \text{ V}$	2		10	MHz
		AN0_0 to AN0_7 input, AN2_0 to AN2_7 input	$4.0 \text{ V} \leq V_{CC2} \leq 5.5 \text{ V}$	2		25	MHz
			$3.2 \text{ V} \leq V_{CC2} \leq 4.0 \text{ V}$	2		16	MHz
			$3.0 \text{ V} \leq V_{CC2} \leq 3.2 \text{ V}$	2		10	MHz

Note:

1. Use when $AV_{CC} = V_{CC1}$.

5. Settings

Figure 5.1 shows the Setting Procedure When Using One-Shot Mode. Refer to the User's Manual: Hardware for details on registers.

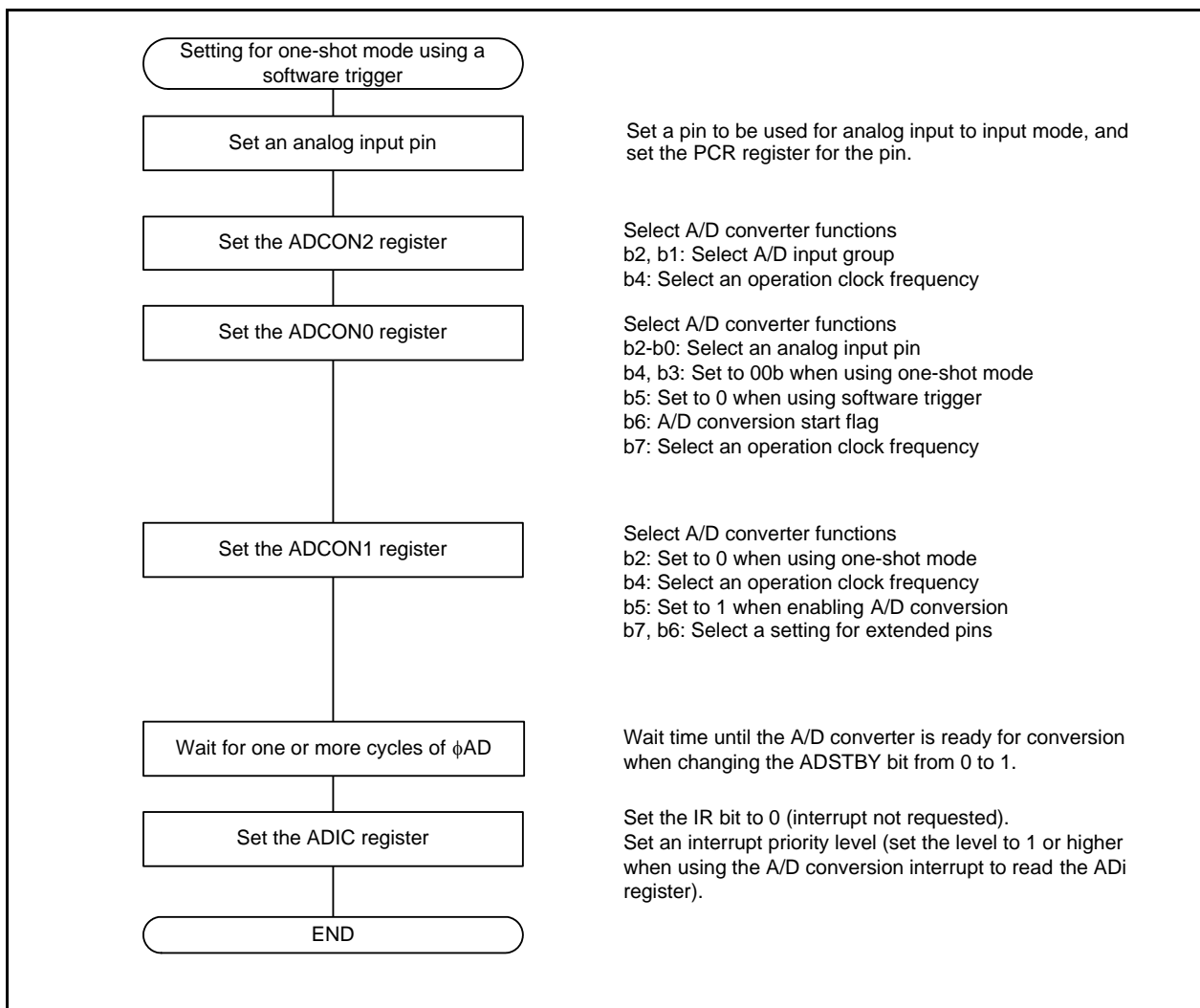

Figure 5.1 Setting Procedure When Using One-Shot Mode

6. Sample Code

A sample code can be downloaded from the Renesas Electronics website.
To download, click “Application Notes” in the left-hand side menu of the M16C Family page.

6.1 Sample Code Operation

In one-shot mode, functions listed in Table 6.1 can be selected. The settings used in the sample code are marked with “✓” in the table. The sample code operation is as follows; set the CPU clock as the main clock with no division by executing functions for CPU initialization, transition from 125 kHz on-chip oscillator mode to high-speed mode, and execute the function for A/D conversion in one-shot mode. Then set the I flag to 1 (maskable interrupts enabled), and start A/D conversion by setting the ADST bit in the ADCON0 register to 1. Use the A/D conversion interrupt to read the conversion result from the ADi register (i = 0 to 7). Refer to 6.2 Function Tables for details on functions.

Table 6.1 Sample Code Settings

Functions	Settings	
Operating clock ϕ_{AD}	✓	f1
		f1 divided by 2
		f1 divided by 3
		f1 divided by 4
		f1 divided by 6
		f1 divided by 12
A/D conversion start conditions	✓	Software trigger
		Trigger by \overline{ADTRG}
Analog input pins	✓	1 pin from AN0 to AN7
		1 pin from AN0_0 to AN0_7
		1 pin from AN2_0 to AN2_7
Extended analog input pins	✓	Not used
		ANEX0 pin
		ANEX1 pin
A/D open-circuit detection assist function	✓	Not used

6.2 Function Tables

Function Tables for This Document

Declaration	void ad_oneshot_sw(void)
Outline	A/D conversion in one-shot mode
Argument	None
Variable	None
Returned value	None
Function	Set the A/D converter to one-shot mode and set the functions as marked in Table 6.1. Set an analog input pin to AN0, P10 to input mode, and the interrupt priority level of the A/D conversion interrupt to 1.

Declaration	void _ad_converter(void)
Outline	A/D converter interrupt
Argument	None
Variable	None
Returned value	None
Function	This function is executed when A/D conversion interrupt occurs, and executes read_ad_register().

Declaration	unsigned short read_ad_register(unsigned char ch)
Outline	Read A/D register
Argument	unsigned char ch Select the A/D register to be read
Variable	None
Returned value	unsigned short read_ad_data Value read from the A/D register
Function	Read the A/D register selected with the unsigned char ch argument. Then return the read value as a returned value.

Other Function Tables

Declaration	void mcu_init(void)
Outline	CPU initialization
Argument	None
Variable	None
Returned value	None
Function	Set to single-chip mode. Switch the CPU clock from 125 kHz on-chip oscillator mode divided-by-8 to 125 kHz on-chip oscillator mode divided-by-1.

Declaration	void highspeed_from_foco125k(void)
Outline	Transition from 125 kHz on-chip oscillator mode to high-speed mode
Argument	None
Variable	None
Returned value	None
Function	Switch the CPU clock from 125 kHz on-chip oscillator mode (fOCO-S divided by 1) to high-speed mode.

7. Reference Documents

M16C/64A Group User's Manual: Hardware Rev.1.10

The latest version can be downloaded from the Renesas Electronics website.

Technical Update/Technical News

The latest information can be downloaded from the Renesas Electronics website.

M16C Series/R8C Family C Compiler Package V.5.45 C Compiler User's Manual Rev.3.00

The latest version can be downloaded from the Renesas Electronics website.

Website and Support

Renesas Electronics website

<http://www.renesas.com/>

Inquiries

<http://www.renesas.com/inquiry>

Revision History	M16C/64A Group Using One-Shot Mode (Software Trigger)
------------------	--

Rev.	Date	Description	
		Page	Summary
1.00	2011.03.15	—	First edition issued

All trademarks and registered trademarks are the property of their respective owners.

General Precautions in the Handling of MPU/MCU Products

The following usage notes are applicable to all MPU/MCU products from Renesas. For detailed usage notes on the products covered by this manual, refer to the relevant sections of the manual. If the descriptions under General Precautions in the Handling of MPU/MCU Products and in the body of the manual differ from each other, the description in the body of the manual takes precedence.

1. Handling of Unused Pins

Handle unused pins in accord with the directions given under Handling of Unused Pins in the manual.

- The input pins of CMOS products are generally in the high-impedance state. In operation with an unused pin in the open-circuit state, extra electromagnetic noise is induced in the vicinity of LSI, an associated shoot-through current flows internally, and malfunctions occur due to the false recognition of the pin state as an input signal become possible. Unused pins should be handled as described under Handling of Unused Pins in the manual.

2. Processing at Power-on

The state of the product is undefined at the moment when power is supplied.

- The states of internal circuits in the LSI are indeterminate and the states of register settings and pins are undefined at the moment when power is supplied.

In a finished product where the reset signal is applied to the external reset pin, the states of pins are not guaranteed from the moment when power is supplied until the reset process is completed.

In a similar way, the states of pins in a product that is reset by an on-chip power-on reset function are not guaranteed from the moment when power is supplied until the power reaches the level at which resetting has been specified.

3. Prohibition of Access to Reserved Addresses

Access to reserved addresses is prohibited.

- The reserved addresses are provided for the possible future expansion of functions. Do not access these addresses; the correct operation of LSI is not guaranteed if they are accessed.

4. Clock Signals

After applying a reset, only release the reset line after the operating clock signal has become stable. When switching the clock signal during program execution, wait until the target clock signal has stabilized.

- When the clock signal is generated with an external resonator (or from an external oscillator) during a reset, ensure that the reset line is only released after full stabilization of the clock signal. Moreover, when switching to a clock signal produced with an external resonator (or by an external oscillator) while program execution is in progress, wait until the target clock signal is stable.

5. Differences between Products

Before changing from one product to another, i.e. to one with a different part number, confirm that the change will not lead to problems.

- The characteristics of MPU/MCU in the same group but having different part numbers may differ because of the differences in internal memory capacity and layout pattern. When changing to products of different part numbers, implement a system-evaluation test for each of the products.

Notice

- All information included in this document is current as of the date this document is issued. Such information, however, is subject to change without any prior notice. Before purchasing or using any Renesas Electronics products listed herein, please confirm the latest product information with a Renesas Electronics sales office. Also, please pay regular and careful attention to additional and different information to be disclosed by Renesas Electronics such as that disclosed through our website.
- Renesas Electronics does not assume any liability for infringement of patents, copyrights, or other intellectual property rights of third parties by or arising from the use of Renesas Electronics products or technical information described in this document. No license, express, implied or otherwise, is granted hereby under any patents, copyrights or other intellectual property rights of Renesas Electronics or others.
- You should not alter, modify, copy, or otherwise misappropriate any Renesas Electronics product, whether in whole or in part.
- Descriptions of circuits, software and other related information in this document are provided only to illustrate the operation of semiconductor products and application examples. You are fully responsible for the incorporation of these circuits, software, and information in the design of your equipment. Renesas Electronics assumes no responsibility for any losses incurred by you or third parties arising from the use of these circuits, software, or information.
- When exporting the products or technology described in this document, you should comply with the applicable export control laws and regulations and follow the procedures required by such laws and regulations. You should not use Renesas Electronics products or the technology described in this document for any purpose relating to military applications or use by the military, including but not limited to the development of weapons of mass destruction. Renesas Electronics products and technology may not be used for or incorporated into any products or systems whose manufacture, use, or sale is prohibited under any applicable domestic or foreign laws or regulations.
- Renesas Electronics has used reasonable care in preparing the information included in this document, but Renesas Electronics does not warrant that such information is error free. Renesas Electronics assumes no liability whatsoever for any damages incurred by you resulting from errors in or omissions from the information included herein.
- Renesas Electronics products are classified according to the following three quality grades: "Standard", "High Quality", and "Specific". The recommended applications for each Renesas Electronics product depends on the product's quality grade, as indicated below. You must check the quality grade of each Renesas Electronics product before using it in a particular application. You may not use any Renesas Electronics product for any application categorized as "Specific" without the prior written consent of Renesas Electronics. Further, you may not use any Renesas Electronics product for any application for which it is not intended without the prior written consent of Renesas Electronics. Renesas Electronics shall not be in any way liable for any damages or losses incurred by you or third parties arising from the use of any Renesas Electronics product for an application categorized as "Specific" or for which the product is not intended where you have failed to obtain the prior written consent of Renesas Electronics. The quality grade of each Renesas Electronics product is "Standard" unless otherwise expressly specified in a Renesas Electronics data sheets or data books, etc.
Standard: Computers; office equipment; communications equipment; test and measurement equipment; audio and visual equipment; home electronic appliances; machine tools; personal electronic equipment; and industrial robots.
High Quality: Transportation equipment (automobiles, trains, ships, etc.); traffic control systems; anti-disaster systems; anti-crime systems; safety equipment; and medical equipment not specifically designed for life support.
Specific: Aircraft; aerospace equipment; submersible repeaters; nuclear reactor control systems; medical equipment or systems for life support (e.g. artificial life support devices or systems), surgical implantations, or healthcare intervention (e.g. excision, etc.), and any other applications or purposes that pose a direct threat to human life.
- You should use the Renesas Electronics products described in this document within the range specified by Renesas Electronics, especially with respect to the maximum rating, operating supply voltage range, movement power voltage range, heat radiation characteristics, installation and other product characteristics. Renesas Electronics shall have no liability for malfunctions or damages arising out of the use of Renesas Electronics products beyond such specified ranges.
- Although Renesas Electronics endeavors to improve the quality and reliability of its products, semiconductor products have specific characteristics such as the occurrence of failure at a certain rate and malfunctions under certain use conditions. Further, Renesas Electronics products are not subject to radiation resistance design. Please be sure to implement safety measures to guard them against the possibility of physical injury, and injury or damage caused by fire in the event of the failure of a Renesas Electronics product, such as safety design for hardware and software including but not limited to redundancy, fire control and malfunction prevention, appropriate treatment for aging degradation or any other appropriate measures. Because the evaluation of microcomputer software alone is very difficult, please evaluate the safety of the final products or system manufactured by you.
- Please contact a Renesas Electronics sales office for details as to environmental matters such as the environmental compatibility of each Renesas Electronics product. Please use Renesas Electronics products in compliance with all applicable laws and regulations that regulate the inclusion or use of controlled substances, including without limitation, the EU RoHS Directive. Renesas Electronics assumes no liability for damages or losses occurring as a result of your noncompliance with applicable laws and regulations.
- This document may not be reproduced or duplicated, in any form, in whole or in part, without prior written consent of Renesas Electronics.
- Please contact a Renesas Electronics sales office if you have any questions regarding the information contained in this document or Renesas Electronics products, or if you have any other inquiries.
(Note 1) "Renesas Electronics" as used in this document means Renesas Electronics Corporation and also includes its majority-owned subsidiaries.
(Note 2) "Renesas Electronics product(s)" means any product developed or manufactured by or for Renesas Electronics.



SALES OFFICES

Renesas Electronics Corporation

<http://www.renesas.com>

Refer to "<http://www.renesas.com/>" for the latest and detailed information.

Renesas Electronics America Inc.
2880 Scott Boulevard Santa Clara, CA 95050-2554, U.S.A.
Tel: +1-408-586-6000, Fax: +1-408-588-6130

Renesas Electronics Canada Limited
1101 Nicholson Road, Newmarket, Ontario L3Y 9C3, Canada
Tel: +1-905-898-5441, Fax: +1-905-898-3220

Renesas Electronics Europe Limited
Dukes Meadow, Millboard Road, Bourne End, Buckinghamshire, SL8 5FH, U.K.
Tel: +44-1628-585-100, Fax: +44-1628-585-900

Renesas Electronics Europe GmbH
Arcadiastrasse 10, 40472 Düsseldorf, Germany
Tel: +49-211-65030, Fax: +49-211-6503-1327

Renesas Electronics (China) Co., Ltd.
7th Floor, Quantum Plaza, No.27 ZhiChunLu Haidian District, Beijing 100083, P.R.China
Tel: +86-10-8235-1155, Fax: +86-10-8235-7679

Renesas Electronics (Shanghai) Co., Ltd.
Unit 204, 205, AZIA Center, No.1233 Lujiazui Ring Rd., Pudong District, Shanghai 200120, China
Tel: +86-21-5877-1818, Fax: +86-21-6887-7858 / -7898

Renesas Electronics Hong Kong Limited
Unit 1601-1613, 16/F., Tower 2, Grand Century Place, 193 Prince Edward Road West, Mongkok, Kowloon, Hong Kong
Tel: +852-2886-9318, Fax: +852 2886-9022/9044

Renesas Electronics Taiwan Co., Ltd.
7F, No. 363 Fu Shing North Road Taipei, Taiwan
Tel: +886-2-8175-9600, Fax: +886 2-8175-9670

Renesas Electronics Singapore Pte. Ltd.
1 HarbourFront Avenue, #06-10, Keppel Bay Tower, Singapore 098632
Tel: +65-6213-0200, Fax: +65-6276-8001

Renesas Electronics Malaysia Sdn.Bhd.
Unit 906, Block B, Menara Amcorp, Amcorp Trade Centre, No. 18, Jln Persiaran Barat, 46050 Petaling Jaya, Selangor Darul Ehsan, Malaysia
Tel: +60-3-7955-9390, Fax: +60-3-7955-9510

Renesas Electronics Korea Co., Ltd.
11F., Samik Laved' or Bldg., 720-2 Yeoksam-Dong, Kangnam-Ku, Seoul 135-080, Korea
Tel: +82-2-558-3737, Fax: +82-2-558-5141