

FemtoClock 3 with Broadcom TH5 Ethernet Switch

This application note describes a reference design using a FemtoClock 3 (FC3) device with the Broadcom TH5 Ethernet switch. For more information and FC3 documentation, see [FemtoClock™ Low Phase-Noise Frequency Synthesizers](#).

Contents

- 1. Introduction.....2**
- 2. Broadcom TH5 Ethernet Switch Requirements2**
 - 2.1 Jitter Requirements.....2
 - 2.2 Amplitude Requirements4
 - 2.3 Power-Up Requirements5
- 3. Revision History5**

Figures

- Figure 1. Renesas FC3 with Broadcom TH5 Reference Design2
- Figure 2. FC3 Jitter Raw Data at 312.5MHz (12kHz to 20MHz) Unfiltered.....3
- Figure 3. FC3 Jitter Post-processed at 312.5MHz (12kHz to 20MHz) HPF 4MHz4
- Figure 4. FC3 to TH5 Termination Scheme.....4
- Figure 5. Scope Shot of Amplitude.....5

1. Introduction

FemtoClock 3 (FC3) devices are a family of telecom integrated circuits that are low phase noise jitter attenuators (for example, RC32308A and RC32312A). For FC3 devices that are only frequency clock synthesizers, see the RC22308A and RC22312A.

Using the RC22312A synthesizer, one such application would be to provide clean clocks for a Broadcom Ethernet Switch such as the Tomahawk 5 (TH5) BCM78900 series of devices (see Figure 1).

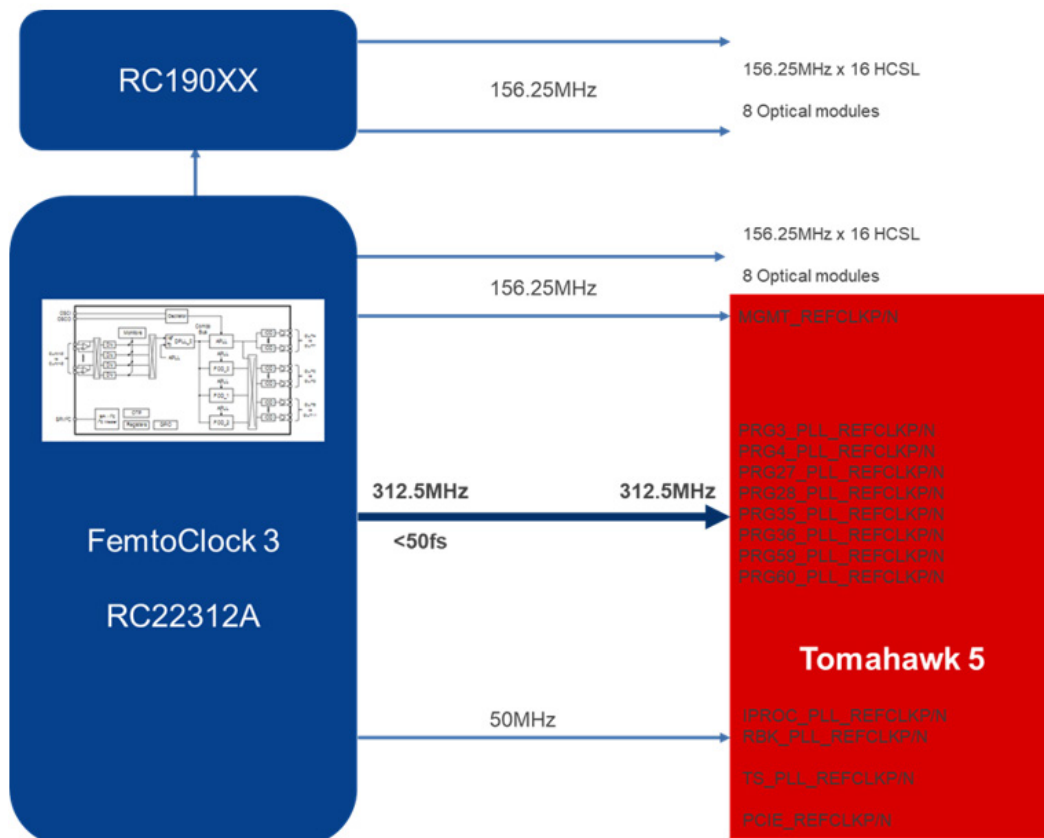

Figure 1. Renesas FC3 with Broadcom TH5 Reference Design

2. Broadcom TH5 Ethernet Switch Requirements

2.1 Jitter Requirements

Broadcom's TH5 has many inputs, but the $8 \times 312.5\text{MHz}$ for the 800GbE SERDES inputs have the most stringent jitter requirements (see Table 1). The RMS jitter needs to be less than 90fs using an integration range between 12kHz to 20MHz that is additionally filtered by a 4MHz high-pass filter (HPF). FC3 can provide roughly 50fs of jitter in that integration range unfiltered for a 312.5MHz output (see Figure 2).

Table 1. TH5 SERDES Input Requirements

Parameter	Minimum	Typical	Maximum	Unit
Frequency	-	312.5	-	MHz
Frequency Deviation	-50 (-25 recommended)	-	+50 (+25 recommended)	ppm
Duty Cycle	40	-	60	%
Rise/Fall Time (20% to 80%)	-	-	360	ps
RMS Jitter (12kHz to 20MHz) with 4MHz HPF	-	-	90	fs
Input Differential Swing	0.8	-	1.4	V

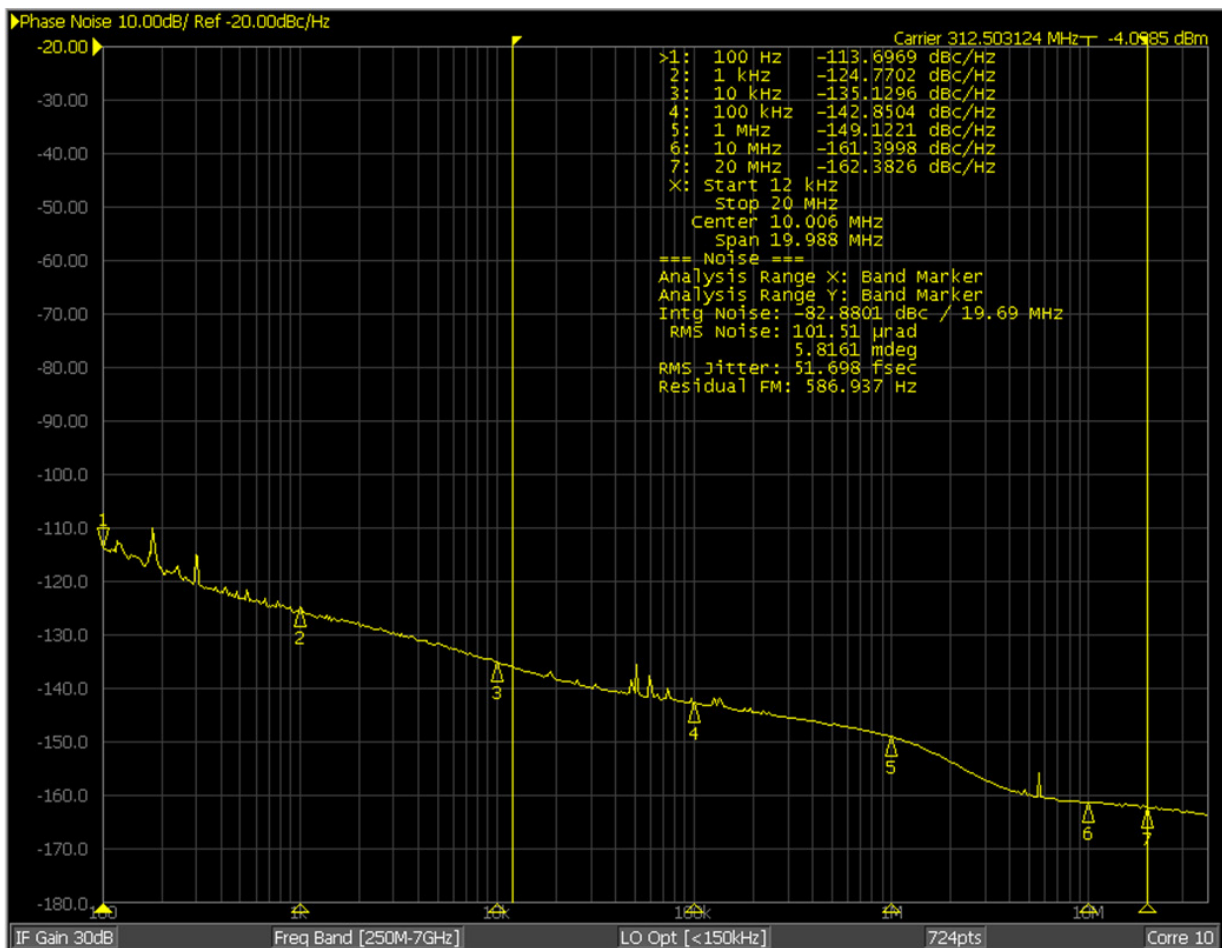

Figure 2. FC3 Jitter Raw Data at 312.5MHz (12kHz to 20MHz) Unfiltered

The Broadcom TH5 312.5MHz input uses a post-processed 4MHz high-pass filter (HPF). FC3 can provide jitter of roughly 25fs when its output is post-processed using a 4MHz HPF (see Figure 3).

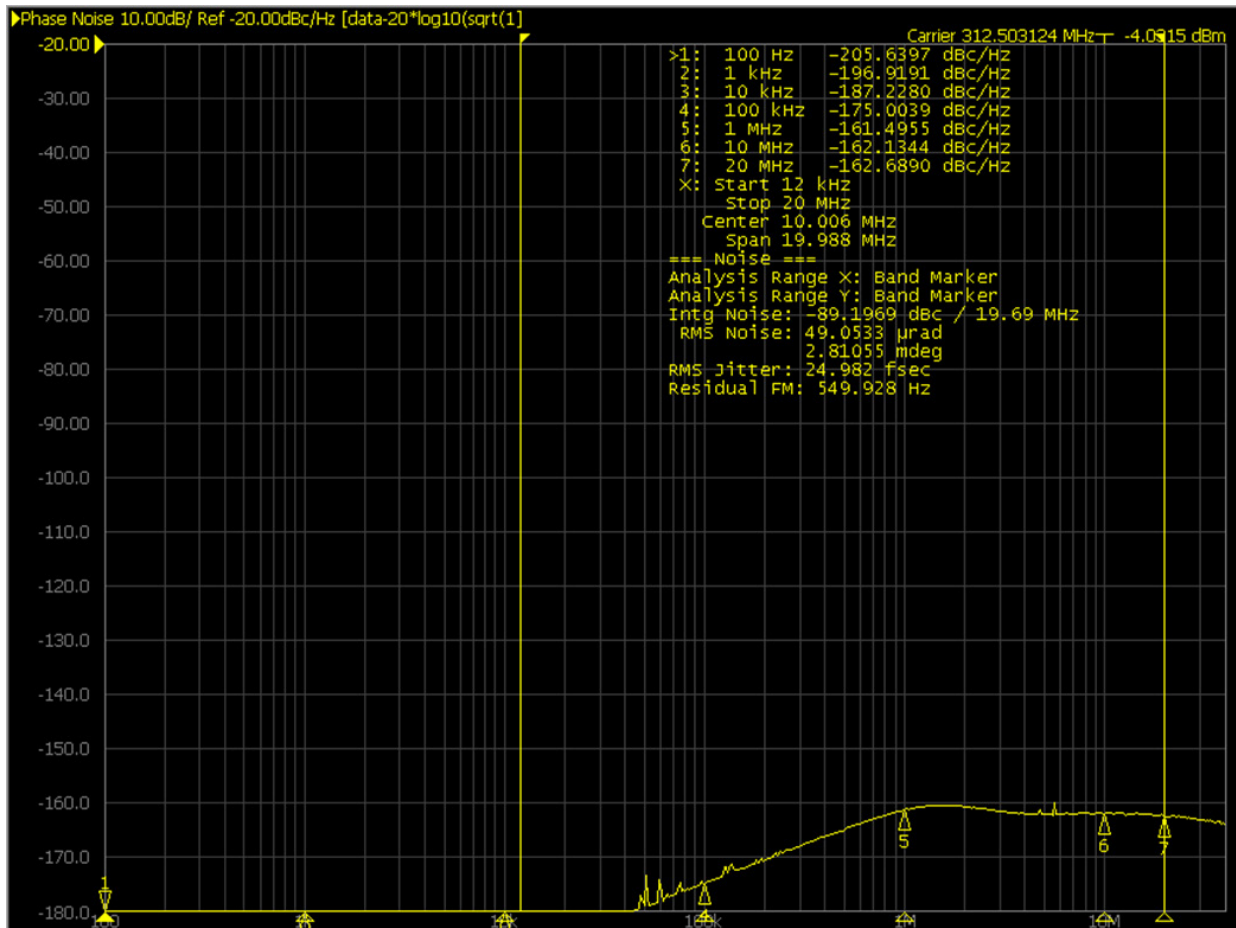

Figure 3. FC3 Jitter Post-processed at 312.5MHz (12kHz to 20MHz) HPF 4MHz

2.2 Amplitude Requirements

The 8 × 312.5MHz TH5 inputs have a differential voltage swing requirement of between 800mVpp 1400mVpp. The Broadcom ASIC has 100Ω between P and N internally. The swing measurement is done at the AC-coupling capacitor, not done at the TH5 pads. Under this condition, the swing is harder to meet because of reflections from the pad back to the capacitor.

Using FC3, that specification can be met with an HCSL register setting to increase the driver current (between 15mA to 19mA) and with external termination enabled ($R_T = 75\Omega$) giving a differential voltage swing of between 900mVpp to 1125mVpp. The FC3 to TH5 termination scheme is shown in Figure 4.

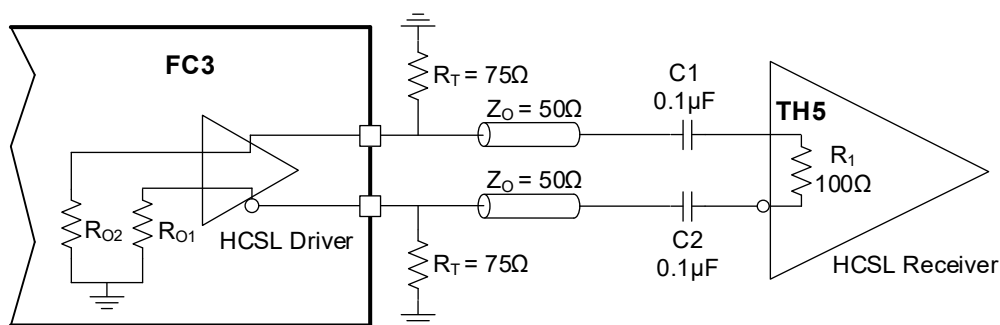

Figure 4. FC3 to TH5 Termination Scheme

Lab tests show an amplitude above 800mV at the capacitor (see Figure 5).



Figure 5. Scope Shot of Amplitude

2.3 Power-Up Requirements

The TH5 device has many power-up and reset timing specifications. The FC3 device is very flexible and can accommodate the various power-up and reset timing specifications of the Broadcom device. The FC3 outputs have an output enable/disable feature.

Note: The input to the TH5 from the FC3 can be activated after the TH5 has been enabled to prevent damage.

3. Revision History

Revision	Date	Description
1.00	Dec 19, 2023	Initial release.

IMPORTANT NOTICE AND DISCLAIMER

RENESAS ELECTRONICS CORPORATION AND ITS SUBSIDIARIES (“RENESAS”) PROVIDES TECHNICAL SPECIFICATIONS AND RELIABILITY DATA (INCLUDING DATASHEETS), DESIGN RESOURCES (INCLUDING REFERENCE DESIGNS), APPLICATION OR OTHER DESIGN ADVICE, WEB TOOLS, SAFETY INFORMATION, AND OTHER RESOURCES “AS IS” AND WITH ALL FAULTS, AND DISCLAIMS ALL WARRANTIES, EXPRESS OR IMPLIED, INCLUDING, WITHOUT LIMITATION, ANY IMPLIED WARRANTIES OF MERCHANTABILITY, FITNESS FOR A PARTICULAR PURPOSE, OR NON-INFRINGEMENT OF THIRD-PARTY INTELLECTUAL PROPERTY RIGHTS.

These resources are intended for developers who are designing with Renesas products. You are solely responsible for (1) selecting the appropriate products for your application, (2) designing, validating, and testing your application, and (3) ensuring your application meets applicable standards, and any other safety, security, or other requirements. These resources are subject to change without notice. Renesas grants you permission to use these resources only to develop an application that uses Renesas products. Other reproduction or use of these resources is strictly prohibited. No license is granted to any other Renesas intellectual property or to any third-party intellectual property. Renesas disclaims responsibility for, and you will fully indemnify Renesas and its representatives against, any claims, damages, costs, losses, or liabilities arising from your use of these resources. Renesas' products are provided only subject to Renesas' Terms and Conditions of Sale or other applicable terms agreed to in writing. No use of any Renesas resources expands or otherwise alters any applicable warranties or warranty disclaimers for these products.

(Disclaimer Rev.1.01)

Corporate Headquarters

TOYOSU FORESIA, 3-2-24 Toyosu,
Koto-ku, Tokyo 135-0061, Japan
www.renesas.com

Trademarks

Renesas and the Renesas logo are trademarks of Renesas Electronics Corporation. All trademarks and registered trademarks are the property of their respective owners.

Contact Information

For further information on a product, technology, the most up-to-date version of a document, or your nearest sales office, please visit www.renesas.com/contact-us/.