

Application Note

Digital Dice

AN-CM-292

Abstract

This application note describes how to design a true random number generator from 1 to 6 with a 7-segment 1-digit LED display. The device is designed to replace commonly used dice.

This application note comes complete with design files which can be found in the References section.

Digital Dice

Contents

Abstract	1
Contents	2
Figures	2
Tables	2
1 Terms and Definitions	3
2 References	3
3 Introduction	4
4 Device Architecture	4
4.1 Entropy Generator.....	4
4.2 Linear Feedback Shift Register.....	5
4.3 Binary to 7-Segment Decoder.....	5
4.4 Control Unit	6
4.5 Macrocell Settings.....	7
5 Conclusions	9
Revision History	10

Figures

Figure 1: Digital Dice Schematic Diagram.....	4
Figure 2: GreenPAK6 Designer Project	4
Figure 3: Entropy Generator.....	5
Figure 4: LFSR	5
Figure 5: Binary to 7 Segment Decoder.....	6
Figure 6: Control Unit	6

Tables

Table 1. LUT Settings.....	7
Table 2: DFF Settings.....	7
Table 3: CNT/DLY Settings	7
Table 4: FILTER Settings	8
Table 5: P DLY Settings	8
Table 6: OSC Settings.....	8
Table 7: PIN Settings.....	8

Digital Dice

1 Terms and Definitions

DFF	D-type Flip Flop
LED	Light-emitting diode
LFSR	Linear feedback shift register
LUT	Lookup table

2 References

For related documents and software, please visit:

[GreenPAK™ Programmable Mixed-Signal Products | Renesas](#)

Download our free [GreenPAK™ Designer](#) software [1] to open the .gp files [2] and view the proposed circuit design. Use the [GreenPAK development tools](#) [3] to freeze the design into your own customized IC in a matter of minutes. Find out more in complete library of application notes [4] featuring design examples as well as explanations of features and blocks within the GreenPAK IC.

[1] [Go Configure™ Software Hub | Renesas](#), Software Download, and User Guide

[2] [AN-CM-292 Digital Dice.gp](#), [GreenPAK Design File](#)

[3] [GreenPAK Development Tools](#), [GreenPAK Development Tools Webpage](#)

[4] [GreenPAK Application Notes](#), [GreenPAK Application Notes Webpage](#)

[5] [SLG46826V](#), Datasheet

[6] [AN-1200 True Random Number Generator Hardware](#)

Author: Nazar Sliunchenko

Digital Dice

3 Introduction

This application note describes how to design Digital Dice, a true random number generator from 1 to 6. This device can be used instead of a commonly used dice. It has a 1-digit 7-segment LED display and two buttons: "Run" and "Display Previous". The Digital Dice can be powered from a single CR-2032 battery. It has no power-on switch due to negligibly low power consumption when idle.

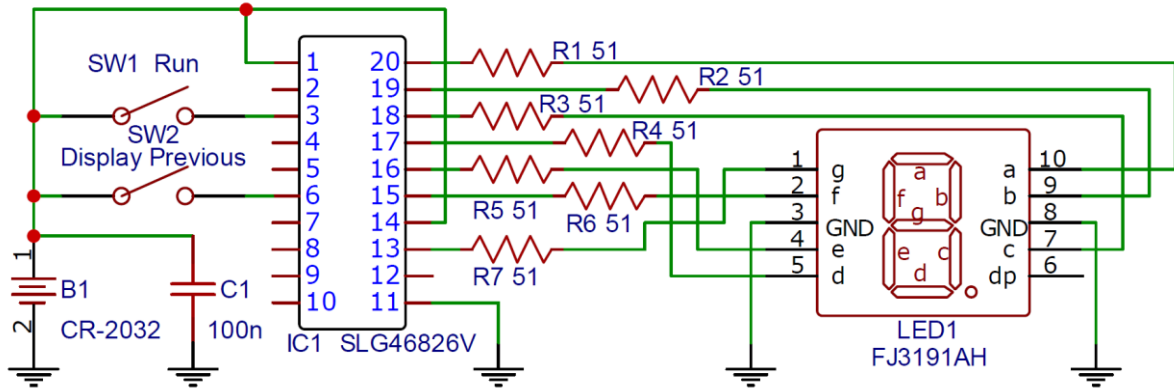

Figure 1: Digital Dice Schematic Diagram

4 Device Architecture

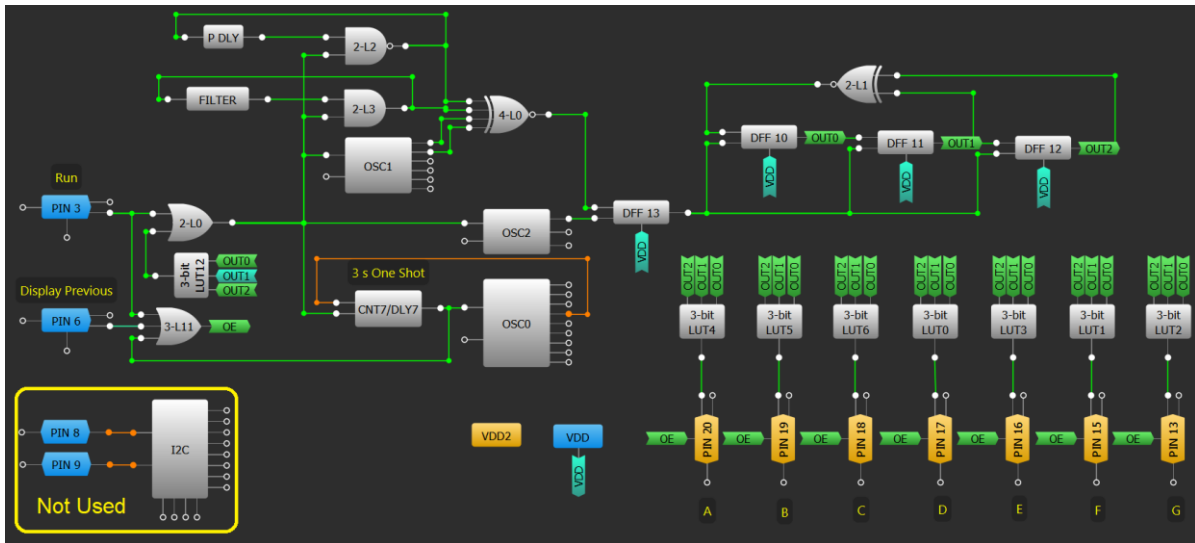

Figure 2: GreenPAK6 Designer Project

The design consists of the following blocks:

4.1 Entropy Generator

The entropy generator is built of four asynchronous oscillators. Two of which are built using an inverted closed-loop LUT with delay (1 MHz and 6.5 MHz). Two others are GreenPAK's OSC1 (2.048 MHz along with a divide by 3) and OSC2 (25 MHz divided by 2).

Digital Dice

Inputting a few asynchronous clock signals to XNOR gate is enough to get an unpredictable signal on its output (noise or entropy). But the macrocells within the SLG46826V allow making even more complicated solutions. Using one more oscillator and DFF we get a completely random signal.

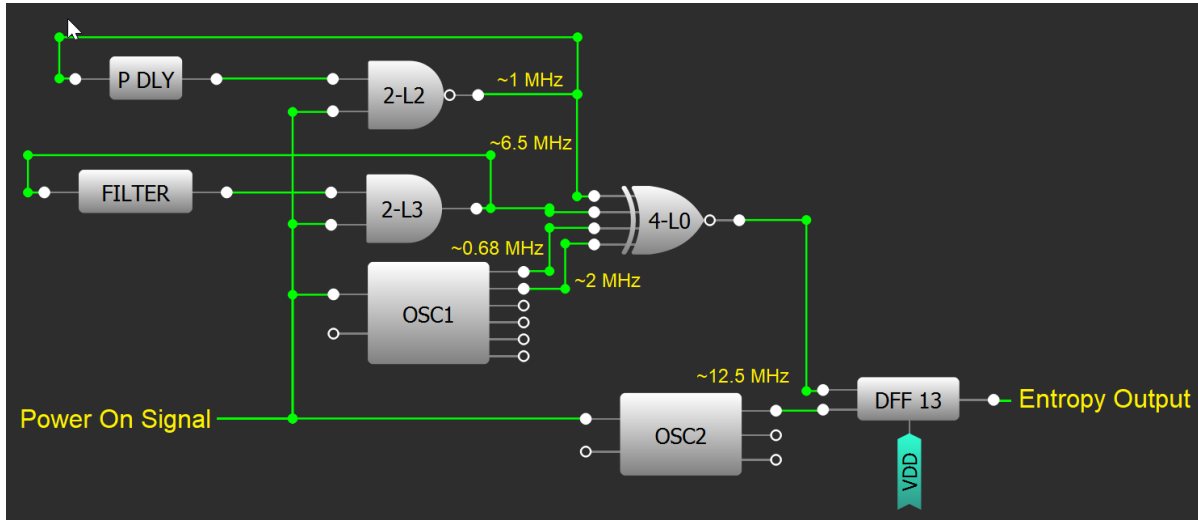

Figure 3: Entropy Generator

4.2 Linear Feedback Shift Register

The 3-bit LFSR is built using three DFFs and one XNOR gate. This block with each input clock generates a 3-bit pseudo-random number. Here, instead of a clock pulse, the noise signal goes into the LFSR's input, generating a true random 3-bit number.

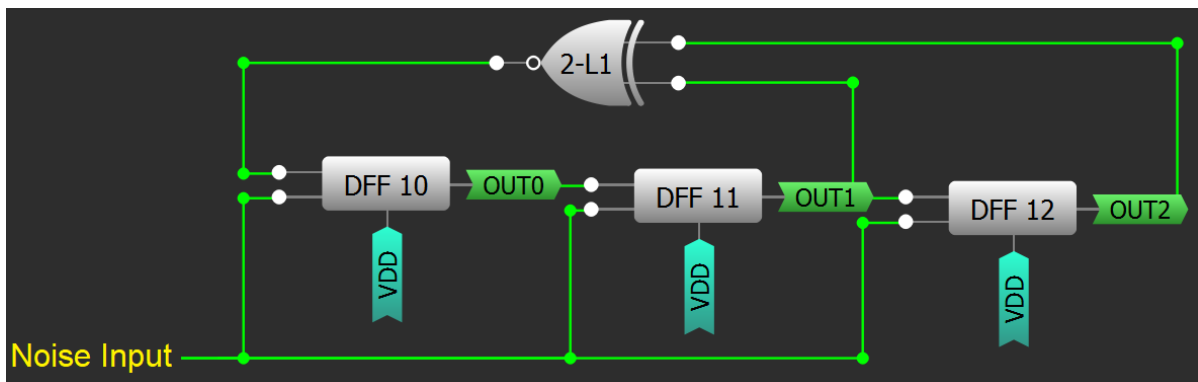

Figure 4: LFSR

4.3 Binary to 7-Segment Decoder

In order to convert the 3-bit random number generated by the LSFR, the Binary to 7-segment decoder is used, see Figure 3. The decoder is built of 3-bit LUTs.

Digital Dice

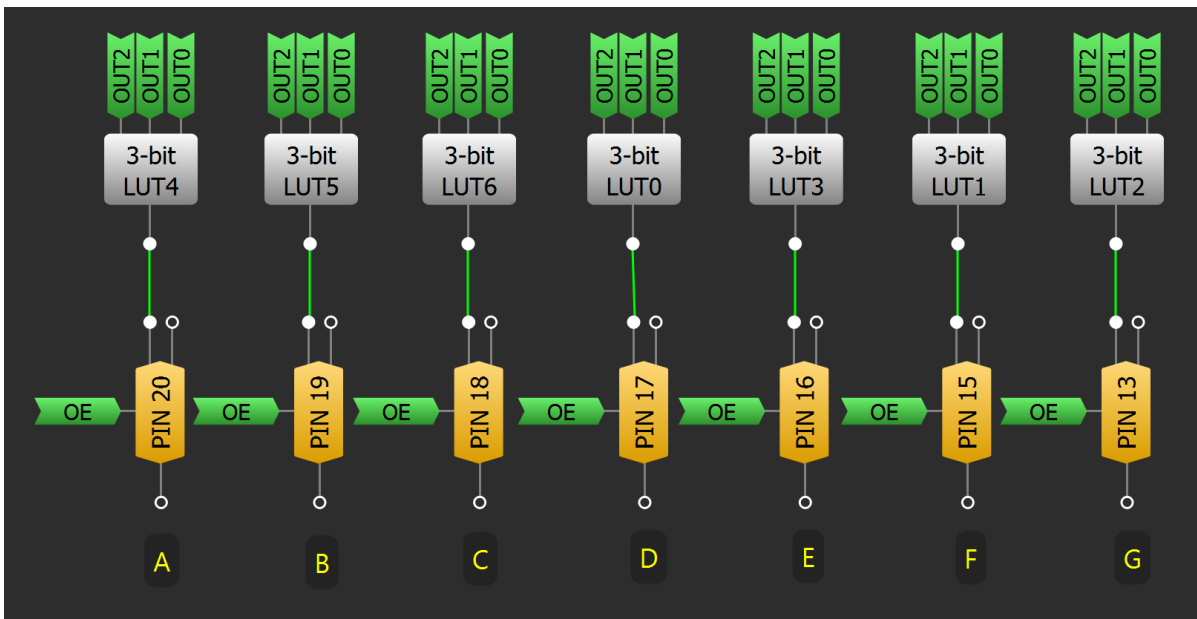

Figure 5: Binary to 7 Segment Decoder

4.4 Control Unit

The control unit is a part of the device designed to start it and stop after the 3-second period. Two pins are configured as inputs and two buttons must be connected from VDD to those pins. While the button "Run" is pressed, the device continuously generates random numbers. Right after the button is released, the generation stops and LFSR latches its outputs. The decoder subsequently drives a 7-segment display. After a 3 second period, the Digital Dice goes idle. The device is still powered on, but because all oscillations have been turned off, the current consumption is extremely low. This allows the device to "remember" the last generated random number. If the button "Display Previous" is pressed, the last generated random number will be displayed until the button is released. Because Digital Dice is designed to replace usual dice, the 3-bit LUT12 is used to restart it when "0" or "7" occurs. This ensures the device will generate a random number in the range of 1 to 6.

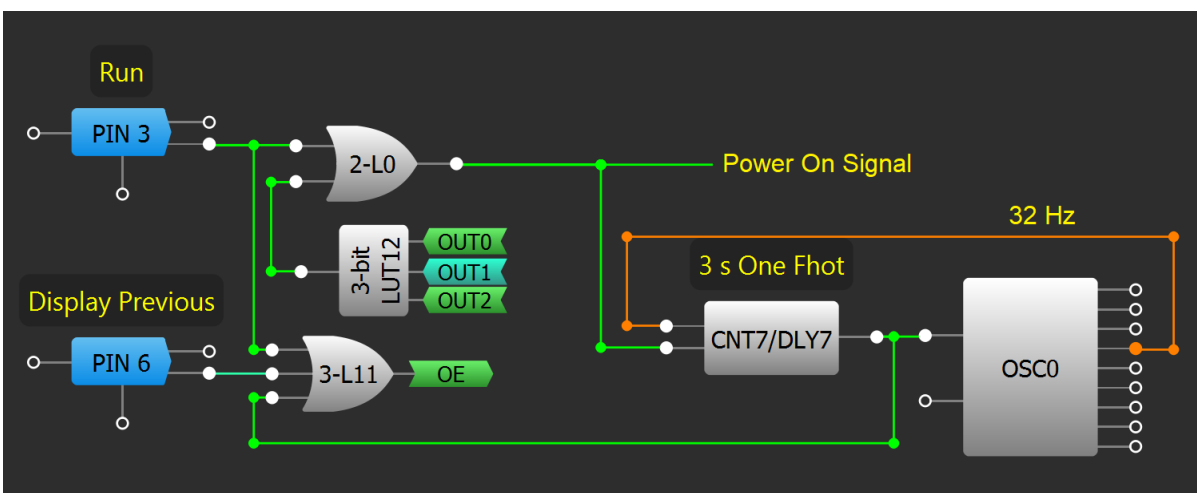

Figure 6: Control Unit

Digital Dice

4.5 Macrocell Settings

For each macrocell, settings refer to the tables below.

Table 1. LUT Settings

IN3	IN2	IN1	IN0	2-bit LUT0 OUT	2-bit LUT1 OUT	2-bit LUT2 OUT	2-bit LUT3 OUT	3-bit LUT0 OUT	3-bit LUT1 OUT	3-bit LUT2 OUT	3-bit LUT3 OUT	3-bit LUT4 OUT	3-bit LUT5 OUT	3-bit LUT6 OUT	3-bit LUT11 OUT	3-bit LUT12 OUT	4-bit LUT0 OUT
0	0	0	0	0	1	1	0	0	0	0	0	0	0	0	0	1	1
0	0	0	1	1	0	1	0	0	0	0	0	0	1	1	1	0	0
0	0	1	0	1	0	1	0	1	0	1	1	1	1	0	1	0	0
0	0	1	1	1	1	0	1	1	0	1	0	1	1	1	1	0	1
0	1	0	0	-	-	-	-	0	1	1	0	0	1	1	1	0	0
0	1	0	1	-	-	-	-	1	1	1	0	1	0	1	1	0	1
0	1	1	0	-	-	-	-	1	1	1	1	1	0	1	1	0	1
0	1	1	1	-	-	-	-	0	0	0	0	0	0	0	1	1	0
1	0	0	0	-	-	-	-	-	-	-	-	-	-	-	-	-	0
1	0	0	1	-	-	-	-	-	-	-	-	-	-	-	-	-	1
1	0	1	0	-	-	-	-	-	-	-	-	-	-	-	-	-	1
1	0	1	1	-	-	-	-	-	-	-	-	-	-	-	-	-	0
1	1	0	0	-	-	-	-	-	-	-	-	-	-	-	-	-	1
1	1	0	1	-	-	-	-	-	-	-	-	-	-	-	-	-	0
1	1	1	0	-	-	-	-	-	-	-	-	-	-	-	-	-	0
1	1	1	1	-	-	-	-	-	-	-	-	-	-	-	-	-	1

Table 2: DFF Settings

Properties	DFFs 10, 11, 12, 13
Multi-function mode	DFF/LATCH
Mode	DFF
nSET/nRESET option	nRESET
Initial polarity	Low
Q output polarity	Non-Inverted (Q)

Table 3: CNT/DLY Settings

Properties	8-bit CNT7/DLY7 (MF)
Multi-function mode	CNT/DLY
Mode	One shot
Counter data	95

Digital Dice

Properties	8-bit CNT7/DLY7 (MF)
Edge select	Falling
DLY IN init. value	Bypass the initial
Output polarity	Non-inverted (OUT)
Mode signal sync.	Bypass
Clock	OSC0 /8

Table 4: FILTER Settings

Properties	8-bit CNT7/DLY7 (MF)
Type	FILTER
Output polarity	Inverted (nOUT)

Table 5: P DLY Settings

Properties	8-bit CNT7/DLY7 (MF)
Mode	Both edge delay
Delay value	500 ns

Table 6: OSC Settings

Properties	OSC0	OSC1	OSC2
Control pin mode	Force on	Force on	Force on
OSC power mode	Auto Power On	Auto Power On	Auto Power On
Clock selector	OSC	OSC	OSC
'CLK' predivider by	8	1	2
'OUT0' second divider by	4	3	-
'OUT1' second divider by	1	1	-
'OUT' second divider by	-	-	1
Start with delay	-	-	Enable

Table 7: PIN Settings

Properties	PINs 3 and 6	PINs 13, 15 to 19	PIN 20
I/O selection	Digital input	Digital input/output	Digital input/output
Input mode	Digital in with Schmitt trigger	Digital in without Schmitt trigger	Digital in without Schmitt trigger
Output mode	None	2x push pull	2x push pull
Resistor	Pull Down	Floating	Floating
Resistor value	100K	Floating	Floating
100 uA pullup on input	None	None	Disable

5 Conclusions

The Digital Dice can be used as a replacement of usual dice in casinos or when playing any other games where dice are needed. It has an entropy generator that is constantly generating 3-bit random numbers while the button "Run" is pressed. It stops and displays the result only when the button is released, so the human factor also affects the generated random number. Four asynchronous oscillators together with human button push variability make the device completely and desirably unpredictable.

Revision History

Revision	Date	Description
1.0	04-Feb-2020	Initial Version

IMPORTANT NOTICE AND DISCLAIMER

RENESAS ELECTRONICS CORPORATION AND ITS SUBSIDIARIES (“RENESAS”) PROVIDES TECHNICAL SPECIFICATIONS AND RELIABILITY DATA (INCLUDING DATASHEETS), DESIGN RESOURCES (INCLUDING REFERENCE DESIGNS), APPLICATION OR OTHER DESIGN ADVICE, WEB TOOLS, SAFETY INFORMATION, AND OTHER RESOURCES “AS IS” AND WITH ALL FAULTS, AND DISCLAIMS ALL WARRANTIES, EXPRESS OR IMPLIED, INCLUDING, WITHOUT LIMITATION, ANY IMPLIED WARRANTIES OF MERCHANTABILITY, FITNESS FOR A PARTICULAR PURPOSE, OR NON-INFRINGEMENT OF THIRD-PARTY INTELLECTUAL PROPERTY RIGHTS.

These resources are intended for developers who are designing with Renesas products. You are solely responsible for (1) selecting the appropriate products for your application, (2) designing, validating, and testing your application, and (3) ensuring your application meets applicable standards, and any other safety, security, or other requirements. These resources are subject to change without notice. Renesas grants you permission to use these resources only to develop an application that uses Renesas products. Other reproduction or use of these resources is strictly prohibited. No license is granted to any other Renesas intellectual property or to any third-party intellectual property. Renesas disclaims responsibility for, and you will fully indemnify Renesas and its representatives against, any claims, damages, costs, losses, or liabilities arising from your use of these resources. Renesas' products are provided only subject to Renesas' Terms and Conditions of Sale or other applicable terms agreed to in writing. No use of any Renesas resources expands or otherwise alters any applicable warranties or warranty disclaimers for these products.

(Disclaimer Rev.1.01)

Corporate Headquarters

TOYOSU FORESIA, 3-2-24 Toyosu,
Koto-ku, Tokyo 135-0061, Japan
www.renesas.com

Trademarks

Renesas and the Renesas logo are trademarks of Renesas Electronics Corporation. All trademarks and registered trademarks are the property of their respective owners.

Contact Information

For further information on a product, technology, the most up-to-date version of a document, or your nearest sales office, please visit www.renesas.com/contact-us/.