

**Introduction**

The CFA has advantages over the VFA. Why not avail yourself of them?

The current feedback amplifier (CFA) has the same ideal closed-loop equations as the voltage feedback amplifier (VFA), but the CFA offers three improvements when compared with the VFA. Generally, CFA's cost less per megahertz of bandwidth, and they don't have the constant gain-bandwidth or slew rate limitations of the VFA. As a result, the CFA's open-loop gain doesn't roll off until much higher frequencies. That typically makes the CFA the amplifier of choice for high-frequency op-amp circuits.

On top of that, the input circuit of the CFA supplies current to the output under transient conditions, and this extra current increases the slew rate. In fact, the CFA often is the best circuit available with its cost-effective combination of high gain, high performance, and low I<sub>cc</sub>. Substituting a CFA for a VFA in the design or production stages will result in better performance and lower cost. The rather straightforward mechanics of the substitution are detailed here.

**Understanding the CFA**

In a CFA model, it can be seen that the noninverting input is connected to the input of a unity gain, which usually takes the form of sophisticated emitter follower circuit, and is modeled by G<sub>B</sub> and Z<sub>B</sub> (Figure 1). Because the noninverting input is actually the input of a buffer, it's a high-impedance input. Also, because this buffer's output connects to the inverting input, CFAs have a lower inverting-input impedance, Z<sub>B</sub>. The inverting-input impedance will be very low (as low as 10Ω). Therefore, the open-loop inverting-input impedance is about equal to (Z<sub>G</sub> + Z<sub>B</sub>), which ranges from 1kΩ to 10Ω.

G<sub>B</sub> possesses a bandwidth greater than the remainder of the amplifier, coupled with a gain that is very close to one, so it is neglected in the calculations. On the other hand, Z<sub>B</sub> is a function of frequency and has a secondary effect on stability, so it must be included in the calculations. The current I, flowing through the inverting input generates a voltage that is equal to the current times the transimpedance, Z. This voltage is modeled by the output voltage source, Z(I). This voltage becomes the output voltage after passing through the output buffer, which is modeled by G<sub>OUT</sub> and Z<sub>OUT</sub>. Again, G<sub>OUT</sub> will be neglected for the same reasons that G<sub>B</sub> was neglected. Z<sub>OUT</sub> is a function of frequency and can have an effect at higher frequencies under capacitive-load conditions, but it will be neglected because these effects are easily calculated and are minimal under normal loading.

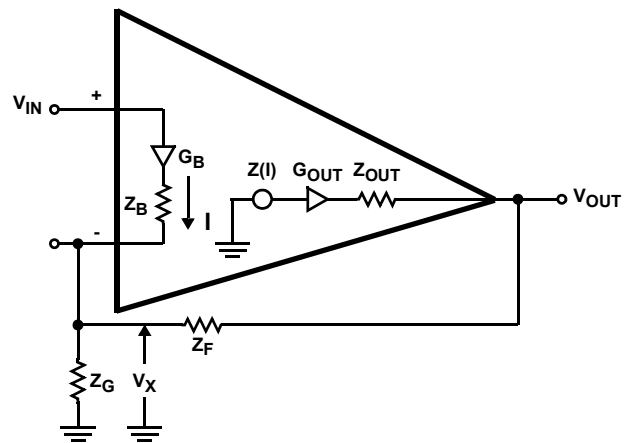

FIGURE 1. MODEL OF A CURRENT FEEDBACK AMPLIFIER (CFA)

An abbreviated development of the noninverting circuit equations is given here; the complete development of the CFA equations is available in many other sources[1]. Equation 1 is the current equation at the inverting input of the circuit shown in Figure 1. Equation 2 is the loop equation for the input circuit, and Equation 3 is the output circuit equation. Applying some algebraic manipulation to these equations yields Equation 4, which is the noninverting closed-loop circuit equation. Equation 5 is the standard feedback equation where A is the direct gain and β is the feedback factor[2].

$$I = \frac{V_X}{Z_G} - \frac{(V_{OUT} - V_X)}{Z_F} \tag{EQ. 1}$$

$$V_X = V_{IN} - IZ_B \tag{EQ. 2}$$

$$V_{OUT} = IZ \tag{EQ. 3}$$

$$\frac{V_{OUT}}{V_{IN}} = \frac{\frac{Z(1 + Z_F/Z_G)}{Z_F(1 + Z_B/Z_F \parallel Z_G)}}{1 + \frac{Z}{Z_F(1 + Z_B/Z_F \parallel Z_G)}} \tag{EQ. 4}$$

$$\frac{V_{OUT}}{V_{IN}} = \frac{A}{1 + A\beta} \tag{EQ. 5}$$

If A is so large that the product Aβ is much greater than one, then the ideal closed-loop gain is equal to 1/β. Also, the stability[3] of Equation 5 is determined by its denominator, or, in other words, by Aβ. As the transimpedance, Z, in Equation 4 approaches infinity, the ideal closed-loop gain becomes G = 1 + Z<sub>F</sub>/Z<sub>G</sub>, which is identical to the VFA noninverting

ideal closed-loop gain. This presents a paradox: If the ideal closed-loop gains are identical, then how does the CFA become independent from the constant-gain-bandwidth limitation of the VFA?

If the input buffer were perfect, the quantity  $Z_B$  in Equation 4 would be zero, and Equation 4 becomes Equation 6 as shown.

$$\frac{V_{OUT}}{V_{IN}} = \frac{Z(1 + Z_F/Z_G)}{Z_F \left(1 + \frac{Z}{Z_F}\right)} \quad (\text{EQ. 6})$$

A close inspection of Equation 6 indicates that the CFA has the same ideal closed-loop gain as the transimpedance gets very large, but  $Z_G$  is eliminated from the denominator when  $Z_B$  is zero. The stability is determined by the denominator, and the denominator is independent of  $Z_G$ . Thus, the stability is independent of the closed-loop gain, and the constant-gain-bandwidth limitation doesn't exist.

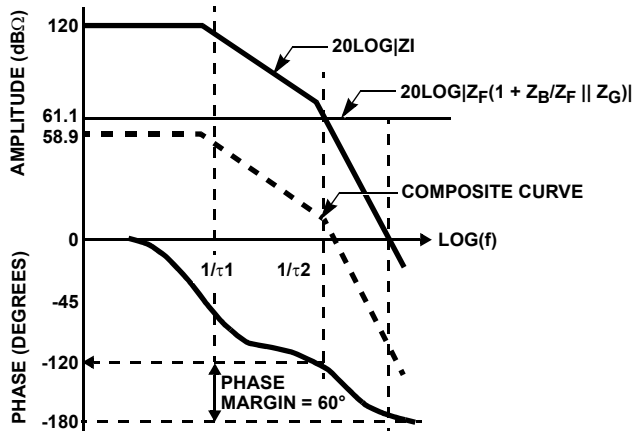

**FIGURE 2. THROUGH LOG (BODE) PLOTS OF STABILITY FOR A CFA, THE CIRCUIT DESIGNER CAN MANIPULATE INDEPENDENT VARIABLES SEPARATELY TO ANALYZE THEIR INDIVIDUAL EFFECTS**

The equation for the inverting configuration is developed with the same techniques used to develop the noninverting equation and is given as Equation 7. Notice that the denominators of Equations 4 and Equation 7 are identical. This is because stability depends solely on the loop gain,  $A\beta$ , given in Equation 8, and not on the placement of the inputs.

$$\frac{V_{OUT}}{V_{IN}} = -\frac{\frac{Z}{Z_G(1 + Z_B/Z_F || Z_G)}}{1 + \frac{Z}{Z_F(1 + Z_B/Z_F || Z_G)}} \quad (\text{EQ. 7})$$

$$A\beta = \frac{Z}{Z_F(1 + Z_B/Z_F || Z_G)} \quad (\text{EQ. 8})$$

## Stability and Resistors

Equation 9 gives the criteria for stability, but there several methods for evaluating this criteria. The method used in this article is called the Bode plot[4], which is a log plot of the stability equation. A brief explanation of the Bode-plot procedure is provided in the publication Feedback, Op Amps and Compensation[5].

The magnitude and phase of the open-loop transfer function are both plotted on logarithmic scales, and if the gain declines below 0dB before the phase shift reaches  $-180^\circ$ , the circuit is stable. In practice, the negative phase shift should be  $\leq 140^\circ$ , or greater than  $40^\circ$  phase margin, to obtain a well behaved circuit.

$$1 + A\beta = 0 \text{ or } A\beta = -1 = |1| \angle -180^\circ \quad (\text{EQ. 9})$$

$$20\log |A\beta| = 20\log \left| \frac{Z}{Z_F(1 + Z_B/Z_F || Z_G)} \right| \quad (\text{EQ. 10})$$

$$\phi = \text{Tangent}^{-1} \frac{Z}{Z_F(1 + Z_B/Z_F || Z_G)} \quad (\text{EQ. 11})$$

The answer to the stability question is found by plotting these functions on log paper. The stability equation  $20\log |A\beta|$ , for the CFA has the form  $20\log(x/y)$ , which can be written as  $20\log(x/y) = 20\log(x) - 20\log(y)$ . The numerator and denominator of Equation 10 will be operated on separately, plotted independently, and then added graphically for analysis. Using this procedure, the independent variables can be manipulated separately to show their individual effects. This is given in a plot of Equation 10 for a typical CFA, where  $Z = 1M\Omega(\tau_1S + 1)(\tau_2S + 1)$ ;  $Z_F = Z_G = 1k\Omega$ ; and  $Z_B = 70\Omega$  (Figure 2).

If  $20\log |Z_F(1 + Z_B/Z_F || Z_G)|$  were equal to 0dB, the circuit would oscillate because the phase shift of  $Z$  reaches  $-180^\circ$  before  $20\log |Z|$  falls below 1. Because  $20\log |Z_F(1 + Z_B/Z_F || Z_G)| = 61.1\text{dB}\Omega$ , the transimpedance curve moves down by that amount to  $58.9\text{dB}\Omega$ , where it's stable because it has  $-120^\circ$  phase shift or  $60^\circ$  phase margin. Notice that when  $Z_F$  approaches zero (represented by a short circuit from the output to negative input), which is typical of a unity gain VFA,  $A\beta = Z/Z_B$ , and because  $Z_B$  is very small, the circuit tends to become unstable.

This explains why the CFA, when configured in a noninverting gain of one circuit, must have a properly selected feedback resistor to prevent oscillations. Placing diodes or capacitors across or in place of the feedback resistor will cause oscillations because they simulate good short circuits at some point in their transfer functions. Remember that oscillation is always preceded by overshoot and ringing as the phase margin decreases, so if the circuit has too much overshoot, the stray feedback capacitance may be too high, or  $R_F$  may be too low. If  $Z_B = 0\Omega$  and  $Z_F = R_F$ , then  $A\beta = Z/R_F$ . In this special case, stability is only a function of  $Z$  and  $R_F$ , and  $R_F$  can be specified to guarantee stability.

The first conclusion drawn here is that  $Z_F(1 + Z_B/Z_F \parallel Z_G)$  impacts stability, and that because the feedback resistor is the preeminent part of that quantity, it has the dominant impact on stability. The dominant selection criteria for  $R_F$  is to obtain the widest bandwidth with an acceptable amount of peaking: 60° phase margin is equivalent to about 10% overshoot. The second conclusion is that the input buffer's output impedance,  $Z_B$ , will have a minor effect on stability because it's small compared to the feedback resistor, even though it is multiplied by  $1/Z_F \parallel Z_G$ .

Rewriting Equation 8 as  $A\beta = Z(Z_F + Z_B(1 + R_F/R_G))$  leads to the third conclusion, which is that the closed-loop gain has a minor effect on stability and bandwidth because it's multiplied by  $Z_B$ , which is a small quantity relative to  $Z_F$ . It's because of this third conclusion that many people claim closed-loop gain versus bandwidth independence for the CFA, but that claim depends on the value of  $Z_B$  relative to  $Z_F$ .

The manufacturer selects optimum values for  $R_F$  during circuit characterization, but different  $R_F$  values can be selected for each different closed-loop gain to yield the best transient performance. An easy way to select a new value of  $R_F$  is to review the manufacturer's data sheet and interpolate or extrapolate to determine  $R_F$  and bandwidth values outside those given by the manufacturer.

### Real-Life Conversions

Most VFA-to-CFA conversions are made in the initial design stages, but the cost and performance advantages of CFAs can dictate that conversions occur while in production. Because the ideal closed-loop equations are identical, it's possible to directly substitute a CFA in a VFA socket with no PC board changes. When the direct substitution happens, it's because the VFA circuit used a feedback resistor, and good grounding and power-distribution techniques aided the board layout.

Several in-production substitutions have been undertaken because CFAs are less expensive for high-frequency applications. All direct substitutions require extensive testing before the new design hits production.

Sometimes it's impossible to implement a direct substitution either because  $R_F$  wasn't included in the original design, feedback capacitors were used, or  $R_F$  was paralleled by diodes. In these cases, the circuit will have to be modified so that  $R_F$  can control the stability. Diodes in the feedback loop often can be replaced by input or output clamp diodes, and feedback capacitors can be neutralized by putting a resistance in series with them. Or, they could be replaced by other filtering techniques.

The integrator configuration is especially hard for a CFA to perform because it requires a feedback capacitor. This can be done, however, by placing the capacitor in the CFA's positive-input circuit or by buffering the capacitor with another amplifier.

The bias currents in a CFA aren't correlated like they are in a VFA. The VFA uses a differential-transistor pair in the input, and because the differential pair is matched, its bias currents also are matched. Applications using VFAs can take advantage of the matched bias currents to cancel them so that the resulting circuit only sees the difference in the bias currents as an error source. CFA inputs are the input and output of a buffer. This means that the positive input current is really a bias current, while the negative input current is the buffer's output current. Manufacturers attempt to minimize the inverting-input current because it generates an offset voltage by flowing through  $R_F$ . In most cases, noninverting input current isn't critical in high-frequency amplifier circuits because low source impedances keep the voltage generated by the input currents low. There is little need for DC precision in high frequency circuits, so the small DC offset is acceptable. The CFA and VFA have similar offset voltages, so this isn't a problem in precision design.

### Watch Layout

Any high-frequency circuit requires attention to layout details, and CFA circuits are no exception. Remember, the criteria for referring to an amplifier as "high frequency" is its maximum bandwidth, not the signal frequency or function it performs.

The first criteria of a good layout is a solid ground plane for low-impedance current-return paths that will prevent the return currents from generating noise. This conflicts with the requirement that the stray capacitance associated with the inverting input,  $C_{IN}$ , be kept low to prevent peaking. Equation 8 shows that the value of  $Z_G$  is critical to stability, and any capacitance added to the inverting node will push the circuit toward instability (Figure 3). There's less than 1dB peaking when  $C_{IN}$  or  $C_F$  equal zero. However, when either of these capacitors reaches just 2pF, the peaking is increased by 3dB or more. The way to minimize the node capacitance is to cut away the ground plane under the inverting input and under the traces connected to this node.

This chops up the ground plane slightly, but the noise increase is minimal if it's done correctly.

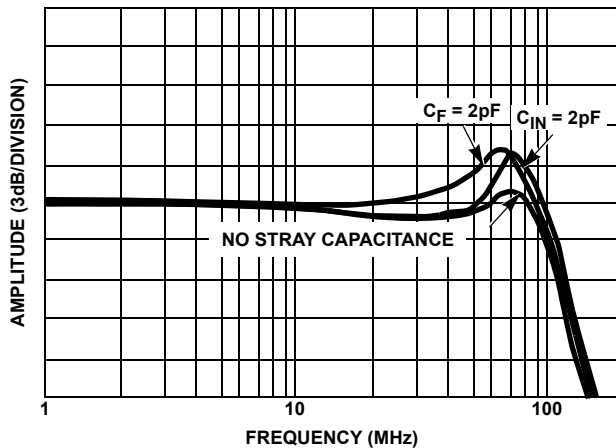

**FIGURE 3. THE EFFECTS OF STRAY CAPACITANCE ON THE CLOSED-LOOP PERFORMANCE OF A CFA**

The IC manufacturer must create good layouts to characterize the CFA. These layouts are typically made available to customers in the form of evaluation boards and artwork. It's very important to initially evaluate a new CFA on the manufacturer's supplied evaluation board. That way, you have a common test bed with the application engineers who characterized the device. If problems or questions arise, the application engineer can quickly emulate or duplicate them on another evaluation board.

Don't be afraid to modify the evaluation boards as required to suit your needs; they will still serve as the platform for getting your design off the ground. The artwork that generates the evaluation boards (Figure 4) contains many engineering hours, and because it isn't copyrighted, you may feel free to use it in your next design. Most IC manufacturers encourage the use of their evaluation-board artwork in a customer's product.

The worst noise sources on a PC board are the logic chips. Be careful when selecting a logic family: Some generate 50mA current spikes when their outputs change state, CMOS families included. These current spikes will generate voltage noise in the ground system, and CFAs have enough bandwidth to amplify the resultant voltage spikes. Analog signals should never be run parallel to digital signals because the edges in the digital signals will inject crosstalk into the analog lines, which creates noise in the analog signals. If PC board-density requirements force you to run analog signals in parallel with digital signals, they should be separated by a trace grounded at one end. The grounded trace acts as a Faraday shield that shunts the digital edges to ground.

Capacitive loads often will make amplifiers ring or oscillate. This can be prevented by inserting a small resistor (27Ω is a good starting value) in series with the output. The isolation resistor will be most effective if it's placed outside the

feedback loop, but it forms a low-pass filter with the load capacitor (Figure 5) and introduces gain errors if driving low resistance loads. If the resistor is put inside the feedback loop, there's little or no filtering effect, and the feedback eliminates the gain error. This technique, however, doesn't work for all amplifiers. In either case, extensive testing is required to determine the correct value. Remember to allow for manufacturing tolerances by choosing a larger resistor than seems necessary.

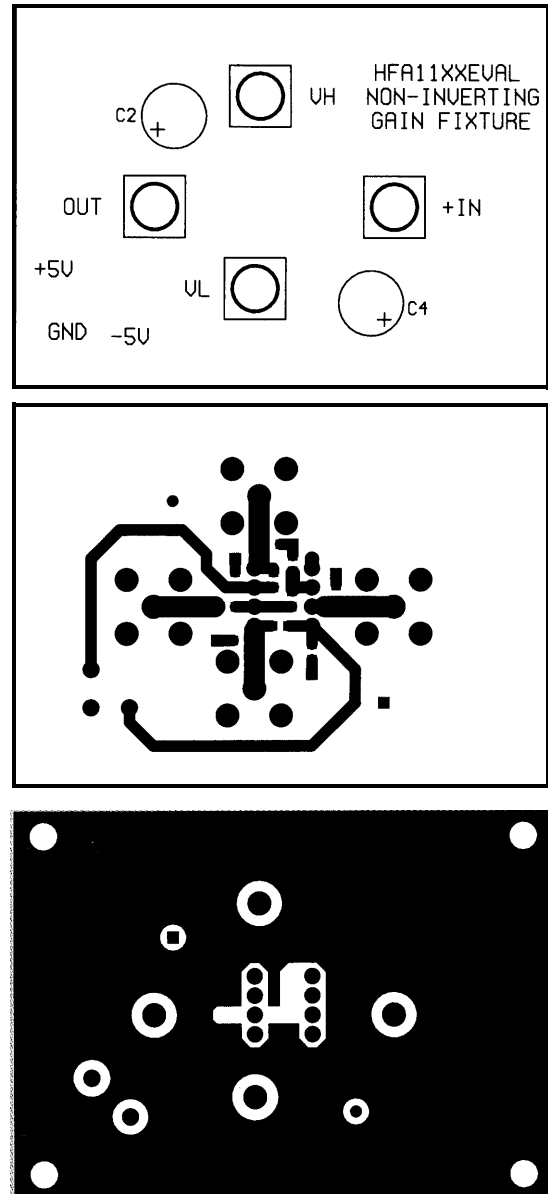

**FIGURE 4. EXAMPLE CFA EVALUATION BOARD ARTWORK**

All active circuits must be decoupled with a good grade of 0.01 $\mu$ F ceramic capacitor. This capacitor circulates return currents at the IC, thus, preventing noise generation. It also acts as a power-supply filter. At high frequencies, the circuit trace between the IC and the power supply acts like a nanohenry-value inductor, so the decoupling capacitor may be your only defense against locally generated noise.

One last item to consider is the selection of the CFA's companion components. Leadless components are preferred because their low lead inductance won't impede high-frequency performance. Components must be small so they can be placed as close as possible to the IC to keep traces short. Also, ensure that the components' self-resonant frequency is much higher than the amplifier's bandwidth. That way, the components will work correctly until the CFA transimpedance has decreased enough to preclude oscillation.

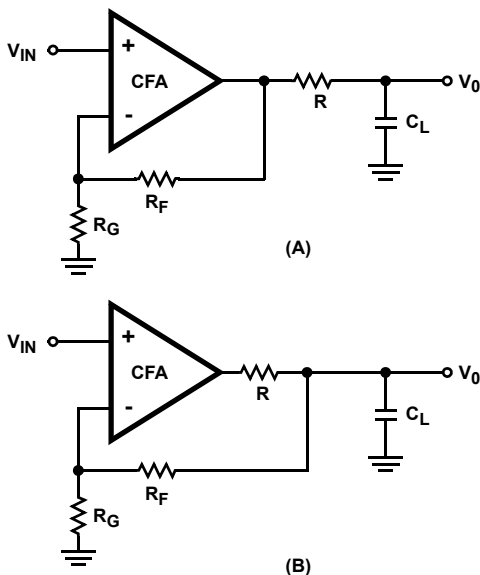

**FIGURE 5. TWO METHODS FOR TAMING LOAD CAPACITANCE EFFECTS: (A) ISOLATION RESISTOR OUTSIDE THE FEEDBACK LOOP. (B) RESISTOR INSIDE THE FEEDBACK LOOP.**

### AC Precision

The error signal expressed as a function of the loop gain for any feedback system is equal to  $V_{IN}/A\beta$  for  $A\beta \gg 1$ :

$$\text{Error} = V_{IN}/(1 + A\beta) \quad (\text{EQ. 12})$$

Consider the HA502X[6] family of CFA ICs in a noninverting gain of +2:  $Z = 6\text{M}\Omega$ ,  $R_F = R_G = 1\text{k}\Omega$ , and  $R_B = 75\Omega$ . Also,  $A\beta = 6,000,000/1000(1 + 75/500) = 5217$ . Then the error =  $1/5217$  or 0.019%. Or conversely, the system is accurate to 12.4 bits because  $N = 1.45\text{Ln}(5217)$ . The HA2841[7] is a high-frequency VFA with accuracy of 15.7 bits at DC. Now consider the same amplifiers at a gain of 10 and a frequency of 1MHz. The CFA's parameters are  $Z = 40\text{k}\Omega$ ,  $R_F = 383\Omega$ ,

and  $R_G = 42.5\Omega$ , so  $A\beta = 35.3$ . This means the accuracy is equivalent to a 5.16-bit system. The same VFA has a loop gain of 10dB at 1MHz, which corresponds to an accuracy of 1.69 bits. Although the DC accuracy of CFAs is lower than that of the VFA at low frequencies, it surpasses the accuracy of VFAs at higher-gain/frequency applications.

### Amplifier Noise

All amplifiers generate internal noise, which they amplify and pass on to other circuits in the signal chain. The input-voltage noise level is comparable in the CFA and the VFA, and in both cases is multiplied by the ideal closed-loop gain. The input-current noise is higher for the CFA, but it doesn't always result in a higher overall-circuit voltage noise because the resistances for CFAs are typically lower.

The noninverting-input current noise is approximately  $2.5 \text{ pA}/(\text{Hz})^{1/2}$ , which is lower than the inverting-input current noise of about  $25 \text{ pA}/(\text{Hz})^{1/2}$ . Because the positive input is typically terminated in  $75\Omega$  or less, the voltage noise contribution attributed to the current noise is  $187.5 \text{ pV}$ . The inverting input current noise is the troublemaker because it's bigger and is multiplied by the feedback resistor. With feedback resistors approaching  $1\text{k}\Omega$ , the resultant noise voltage at the circuit output is  $25 \text{ nV}/(\text{Hz})^{1/2}$ . One way to minimize this noise is to choose CFAs that specify a very low feedback-resistor value.

### Conclusion

In conclusion, the CFA can easily replace the VFA in most high-frequency applications with better performance and lower cost. There are just a few salient points to be aware of during the replacement, and most cases will require either minor or no PC-board changes. But remember that the CFA must have a feedback resistor, thus a CFA can't be substituted directly for a VFA in unity-gain applications in which the output is shorted to the inverting input ( $R_F = 0$ ).

The key to CFA stability is the feedback resistor. A value of  $R_F$  that yields stable operation can always be found. It's best to start with the manufacturer's recommended value, but graphical techniques can be used to select new  $R_F$  values if wider bandwidth or a new closed-loop gain is desired. Remember, lower  $R_F$  increases bandwidth while increasing ringing and overshoot. Don't drop the value of  $R_F$  too much or oscillation will result.

The CFA is optimized for high frequency tasks but not for low-frequency precision work. Although new CFAs have improved precision parameters, there's rarely any advantage in using a high-frequency amplifier when a low-frequency one will do. An exception is when the high-frequency amplifier is bandwidth-limited by an external component to achieve AC stability. The VFA has the higher precision at DC, but as frequency increases, the CFA ends up with the highest precision. This is especially true in high-gain applications.

As with all high-frequency amplifiers, PC-board layout is critical. At one time, it was said that a good layout could gain an extra 10% in bandwidth. Now, an excellent layout is required to achieve stability, and the bandwidth will be a direct function of the layout and the CFA. Peripheral components should also be chosen carefully, because they also contribute to the frequency response.

The CFA doesn't have a constant-gain-bandwidth limitation, so it can be optimized for bandwidth at each new gain. The optimization is implemented by selecting the feedback resistor. Basically speaking, the CFA is no harder to use than a VFA with equivalent bandwidth; it's just a little different.

### **References**

- [1] Mancini, R. and Lies, J., Current Feedback Amplifier Theory and Applications, Intersil Corporation, 1995.
- [2] Mancini, R., Feedback, Op Amps and Compensation, Intersil Corporation, 1995.
- [3] Ibid.
- [4] Bode, H.W., Network Analysis and Feedback Amplifier Design, D. Van Nostrand Inc., 1945.
- [5] Mancini, R., Feedback, Op Amps and Compensation, Intersil Corporation, 1995.
- [6] Data sheet for HA5020, Intersil Corporation, 1995.
- [7] Data sheet for HA-2841 Intersil Corporation, 1995.

## Notice

1. Descriptions of circuits, software and other related information in this document are provided only to illustrate the operation of semiconductor products and application examples. You are fully responsible for the incorporation or any other use of the circuits, software, and information in the design of your product or system. Renesas Electronics disclaims any and all liability for any losses and damages incurred by you or third parties arising from the use of these circuits, software, or information.
  2. Renesas Electronics hereby expressly disclaims any warranties against and liability for infringement or any other claims involving patents, copyrights, or other intellectual property rights of third parties, by or arising from the use of Renesas Electronics products or technical information described in this document, including but not limited to, the product data, drawings, charts, programs, algorithms, and application examples.
  3. No license, express, implied or otherwise, is granted hereby under any patents, copyrights or other intellectual property rights of Renesas Electronics or others.
  4. You shall not alter, modify, copy, or reverse engineer any Renesas Electronics product, whether in whole or in part. Renesas Electronics disclaims any and all liability for any losses or damages incurred by you or third parties arising from such alteration, modification, copying or reverse engineering.
  5. Renesas Electronics products are classified according to the following two quality grades: "Standard" and "High Quality". The intended applications for each Renesas Electronics product depends on the product's quality grade, as indicated below.  
"Standard": Computers; office equipment; communications equipment; test and measurement equipment; audio and visual equipment; home electronic appliances; machine tools; personal electronic equipment; industrial robots; etc.  
"High Quality": Transportation equipment (automobiles, trains, ships, etc.); traffic control (traffic lights); large-scale communication equipment; key financial terminal systems; safety control equipment; etc.  
Unless expressly designated as a high reliability product or a product for harsh environments in a Renesas Electronics data sheet or other Renesas Electronics document, Renesas Electronics products are not intended or authorized for use in products or systems that may pose a direct threat to human life or bodily injury (artificial life support devices or systems; surgical implantations; etc.), or may cause serious property damage (space system; undersea repeaters; nuclear power control systems; aircraft control systems; key plant systems; military equipment; etc.). Renesas Electronics disclaims any and all liability for any damages or losses incurred by you or any third parties arising from the use of any Renesas Electronics product that is inconsistent with any Renesas Electronics data sheet, user's manual or other Renesas Electronics document.
  6. When using Renesas Electronics products, refer to the latest product information (data sheets, user's manuals, application notes, "General Notes for Handling and Using Semiconductor Devices" in the reliability handbook, etc.), and ensure that usage conditions are within the ranges specified by Renesas Electronics with respect to maximum ratings, operating power supply voltage range, heat dissipation characteristics, installation, etc. Renesas Electronics disclaims any and all liability for any malfunctions, failure or accident arising out of the use of Renesas Electronics products outside of such specified ranges.
  7. Although Renesas Electronics endeavors to improve the quality and reliability of Renesas Electronics products, semiconductor products have specific characteristics, such as the occurrence of failure at a certain rate and malfunctions under certain use conditions. Unless designated as a high reliability product or a product for harsh environments in a Renesas Electronics data sheet or other Renesas Electronics document, Renesas Electronics products are not subject to radiation resistance design. You are responsible for implementing safety measures to guard against the possibility of bodily injury, injury or damage caused by fire, and/or danger to the public in the event of a failure or malfunction of Renesas Electronics products, such as safety design for hardware and software, including but not limited to redundancy, fire control and malfunction prevention, appropriate treatment for aging degradation or any other appropriate measures. Because the evaluation of microcomputer software alone is very difficult and impractical, you are responsible for evaluating the safety of the final products or systems manufactured by you.
  8. Please contact a Renesas Electronics sales office for details as to environmental matters such as the environmental compatibility of each Renesas Electronics product. You are responsible for carefully and sufficiently investigating applicable laws and regulations that regulate the inclusion or use of controlled substances, including without limitation, the EU RoHS Directive, and using Renesas Electronics products in compliance with all these applicable laws and regulations. Renesas Electronics disclaims any and all liability for damages or losses occurring as a result of your noncompliance with applicable laws and regulations.
  9. Renesas Electronics products and technologies shall not be used for or incorporated into any products or systems whose manufacture, use, or sale is prohibited under any applicable domestic or foreign laws or regulations. You shall comply with any applicable export control laws and regulations promulgated and administered by the governments of any countries asserting jurisdiction over the parties or transactions.
  10. It is the responsibility of the buyer or distributor of Renesas Electronics products, or any other party who distributes, disposes of, or otherwise sells or transfers the product to a third party, to notify such third party in advance of the contents and conditions set forth in this document.
  11. This document shall not be reprinted, reproduced or duplicated in any form, in whole or in part, without prior written consent of Renesas Electronics.
  12. Please contact a Renesas Electronics sales office if you have any questions regarding the information contained in this document or Renesas Electronics products.
- (Note 1) "Renesas Electronics" as used in this document means Renesas Electronics Corporation and also includes its directly or indirectly controlled subsidiaries.  
(Note 2) "Renesas Electronics product(s)" means any product developed or manufactured by or for Renesas Electronics.

(Rev.4.0-1 November 2017)



### SALES OFFICES

Renesas Electronics Corporation

<http://www.renesas.com>

Refer to "<http://www.renesas.com/>" for the latest and detailed information.

**Renesas Electronics America Inc.**  
1001 Murphy Ranch Road, Milpitas, CA 95035, U.S.A.  
Tel: +1-408-432-8888, Fax: +1-408-434-5351

**Renesas Electronics Canada Limited**  
9251 Yonge Street, Suite 8309 Richmond Hill, Ontario Canada L4C 9T3  
Tel: +1-905-237-2004

**Renesas Electronics Europe Limited**  
Dukes Meadow, Millboard Road, Bourne End, Buckinghamshire, SL8 5FH, U.K  
Tel: +44-1628-651-700, Fax: +44-1628-651-804

**Renesas Electronics Europe GmbH**  
Arcadiastrasse 10, 40472 Düsseldorf, Germany  
Tel: +49-211-6503-0, Fax: +49-211-6503-1327

**Renesas Electronics (China) Co., Ltd.**  
Room 1709 Quantum Plaza, No.27 ZhichunLu, Haidian District, Beijing, 100191 P. R. China  
Tel: +86-10-8235-1155, Fax: +86-10-8235-7679

**Renesas Electronics (Shanghai) Co., Ltd.**  
Unit 301, Tower A, Central Towers, 555 Langao Road, Putuo District, Shanghai, 200333 P. R. China  
Tel: +86-21-2226-0888, Fax: +86-21-2226-0999

**Renesas Electronics Hong Kong Limited**  
Unit 1601-1611, 16/F., Tower 2, Grand Century Place, 193 Prince Edward Road West, Mongkok, Kowloon, Hong Kong  
Tel: +852-2265-6688, Fax: +852-2886-9022

**Renesas Electronics Taiwan Co., Ltd.**  
13F, No. 363, Fu Shing North Road, Taipei 10543, Taiwan  
Tel: +886-2-8175-9600, Fax: +886-2-8175-9670

**Renesas Electronics Singapore Pte. Ltd.**  
80 Bendemeer Road, Unit #06-02 Hyflux Innovation Centre, Singapore 339949  
Tel: +65-6213-0200, Fax: +65-6213-0300

**Renesas Electronics Malaysia Sdn.Bhd.**  
Unit 1207, Block B, Menara Amcorp, Amcorp Trade Centre, No. 18, Jln Persiaran Barat, 46050 Petaling Jaya, Selangor Darul Ehsan, Malaysia  
Tel: +60-3-7955-9390, Fax: +60-3-7955-9510

**Renesas Electronics India Pvt. Ltd.**  
No.777C, 100 Feet Road, HAL 2nd Stage, Indiranagar, Bangalore 560 038, India  
Tel: +91-80-67208700, Fax: +91-80-67208777

**Renesas Electronics Korea Co., Ltd.**  
17F, KAMCO Yangjae Tower, 262, Gangnam-daero, Gangnam-gu, Seoul, 06265 Korea  
Tel: +82-2-558-3737, Fax: +82-2-558-5338