

RS-485 Networks

External Fail-Safe Biasing of RS-485 Networks

AN1986
Rev.1.00
Aug 3, 2017

Abstract

Despite the integrated fail-safe feature of full fail-safe transceivers, RS-485 networks in electrical noisy environments require additional fail-safe biasing in the form of external voltage divider networks. Knowing how to calculate the necessary resistor values ranks at the top of the list of customer inquiries. This application note shows how to apply external fail-safe biasing for short and long distance buses, using the ISL3152E, the industry’s strongest RS-485 transceiver.

Contents

| | |
|---|-----------|
| 1. Introduction | 2 |
| 2. Single Fail-Safe Biasing Network Design | 3 |
| 3. Common-Mode Loading | 5 |
| 4. Dual Fail-Safe Biasing | 6 |
| 4.1 Calculation Examples | 7 |
| 4.2 Transceiver Selection | 7 |
| 5. Conclusion | 10 |
| 6. Revision History | 11 |

List of Figures

| | |
|---|---|
| Figure 1. External Fail-Safe Biasing Network for Short to Medium Bus Distance | 2 |
| Figure 2. Lumped Equivalent Model of Figure 1 Circuit | 3 |
| Figure 3. Lumped Equivalent Model for Dual Fail-Safe Biasing | 6 |
| Figure 4. Differential Output Drive Capability: ISL315x vs Standard RS-485 Transceivers | 8 |
| Figure 5. Common-Mode Output Drive Capability: ISL315x vs Standard RS-485 Transceivers | 8 |

1. Introduction

In RS-485 networks (see [Figure 1](#)), there are periods of time when no driver actively drives the bus, such as when one driver relinquishes the bus to another driver. During this time, the termination resistors collapse the differential bus voltage to 0V, which is an undefined input level for many RS-485 receivers. Faced with this undefined input, a receiver might output the wrong logic state, or worse yet, might oscillate. The oscillation may be interpreted as an “endless” stream of message start bits, so a controller might waste valuable bandwidth trying to service these phantom messages. Fail-safe bus biasing is one way to alleviate this problem.

External fail-safe biasing is accomplished through resistor networks of pull-up, termination, and pull-down resistors whose voltage divider actions provide a differential DC bus voltage, V_{AB} , when no driver is actively driving the bus.

To drive all receiver outputs to the defined idle state of a logic high, V_{AB} must be higher than the maximum input threshold, V_{IT-MAX} . In addition, sufficient noise margin should be added to allow for operation in harsh industrial environments, thus making $V_{AB} = V_{IT-MAX} + V_{Noise}$.

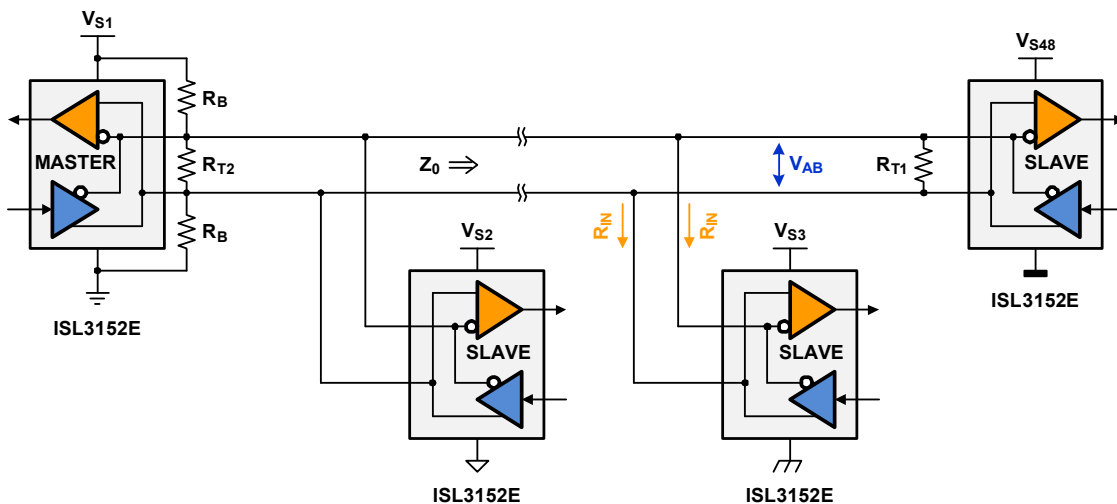

Figure 1. External Fail-Safe Biasing Network for Short to Medium Bus Distance

To help system engineers design successful fail-safe biasing networks, this article derives the equations for calculating the resistor values and the maximum possible bus loading caused by transceivers for single and dual fail-safe terminations. The article also introduces the ISL315x family of high V_{OD} transceivers whose common-mode drive capabilities of 60 unit loads exceeds the 32 ULs of standard transceivers by far.

2. Single Fail-Safe Biasing Network Design

For short network distances of $\leq 100\text{m}$ and low to medium idle-bus voltages of $50\text{mV} \leq V_{AB} \leq 300\text{mV}$, fail-safe biasing at one bus end often suffices. For simplification, the network in [Figure 1](#) is converted into the lumped equivalent circuit of [Figure 2](#) with the bias resistors, R_B , and the termination resistors, R_{T1} and R_{T2} . R_{EQ} represents the equivalent input resistance of all transceivers connected to the bus.

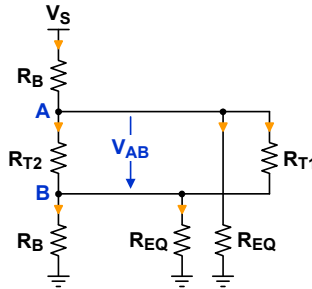

Figure 2. Lumped Equivalent Model of [Figure 1](#) Circuit

Before deriving the equations for calculating the resistor values, we establish the conditions that must be satisfied with regards to line termination and common-mode loading.

- (1) The cable end without the biasing network is terminated with R_{T1} , whose value should match the characteristic impedance of the cable, Z_0 .

$$R_{T1} = Z_0 \quad (\text{EQ. 1})$$

- (2) For line impedance matching during normal operation, the series combination of the two biasing resistors in parallel with the termination resistor, R_{T2} , must match the characteristic cable impedance: $Z_0 = 2R_B \parallel R_{T2}$. Thus, for a given value of R_B , R_{T2} becomes:

$$R_{T2} = \frac{2R_B \cdot Z_0}{2R_B - Z_0} \quad (\text{EQ. 2})$$

- (3) RS-485 specifies the maximum common-mode load, which a standard compliant transceiver must be able to drive, with 32 parallel unit loads (ULs). One unit load represents a minimum common-mode resistance of around $12\text{k}\Omega$ between each signal conductor and ground. Thus, the total common-mode loading of 32 ULs results in a minimum common-mode resistance of $R_{CM} = 375\Omega$. Because the bias resistors present a common-mode load in addition to the equivalent transceiver input resistance, the parallel combination of R_B and R_{EQ} must be greater or equal to R_{CM} : $R_B \parallel R_{EQ} \geq R_{CM}$. For a given R_B value, R_{EQ} is therefore limited to:

$$R_{EQ} = \frac{R_B \cdot R_{CM}}{R_B - R_{CM}} \quad (\text{EQ. 3})$$

To find the equation for calculating R_B , we determine the node currents of A and B in [Figure 2](#) and solve for the individual line voltages, V_A and V_B .

$$\text{Node A) } \frac{V_A}{R_{EQ}} = \frac{V_S - V_A}{R_B} - \frac{V_{AB}}{R_{T2}} - \frac{V_{AB}}{R_{T1}} \quad \Rightarrow \quad V_A = R_{EQ} \left[\frac{V_S}{R_B} - \frac{V_A}{R_B} - V_{AB} \left(\frac{1}{R_{T2}} + \frac{1}{R_{T1}} \right) \right]$$

$$\text{Node B) } \frac{V_B}{R_{EQ}} = \frac{V_{AB}}{R_{T2}} - \frac{V_B}{R_B} + \frac{V_{AB}}{R_{T1}} \quad \Rightarrow \quad V_B = R_{EQ} \left[V_{AB} \left(\frac{1}{R_{T2}} + \frac{1}{R_{T1}} \right) - \frac{V_B}{R_B} \right]$$

Then calculating the difference between the line voltages provides the differential bus voltage with:

$$V_{AB} = R_{EQ} \left\{ \frac{V_S}{R_B} - V_{AB} \cdot \left[\frac{1}{R_B} + 2 \left(\frac{1}{R_{T2}} + \frac{1}{R_{T1}} \right) \right] \right\} \quad (\text{EQ. 4})$$

Inserting EQs. [1](#), [2](#), and [3](#) into [\(EQ. 4\)](#) provides the final equation for the DC-bus idle voltage with:

$$V_{AB} = \frac{V_S}{R_B \left(\frac{1}{R_{CM}} + \frac{4}{Z_0} \right) - 1} \quad (\text{EQ. 5})$$

And solving for R_B yields the minimum required bias resistor value with:

$$R_B \geq \frac{V_S / V_{AB} + 1}{1 / R_{CM} + 4 / Z_0} \quad (\text{EQ. 6})$$

3. Common-Mode Loading

Because external fail-safe biasing presents additional common-mode loading, it is necessary to determine the maximum number of transceiver unit loads, n_{UL} , that can load the bus without dropping below $R_{CM} = 375\Omega$.

n_{UL} is the ratio of the common-mode resistance of one unit load to the common-mode resistance of the transceiver unit load: $n_{UL} = 12k\Omega / R_{EQ}$, and inserting [\(EQ. 3\)](#) for R_{EQ} yields:

$$n_{UL} = 12k\Omega \cdot \left(\frac{1}{R_{CM}} - \frac{1}{R_B} \right) \quad (\text{EQ. 7})$$

This maximum number of transceiver unit loads can be accomplished through the use of $n \times 1$ UL, $2n \times \frac{1}{2}$ UL, $4n \times \frac{1}{4}$ UL, or $8n \times \frac{1}{8}$ UL transceivers.

4. Dual Fail-Safe Biasing

To maintain a constant V_{AB} over long cable lengths, fail-safe biasing at both bus ends is necessary. Here, each biasing network compensates for the loss of biasing of the other network towards along the cable run.

[Figure 3](#) shows the lumped equivalent circuit of a bus with dual fail-safe biasing.

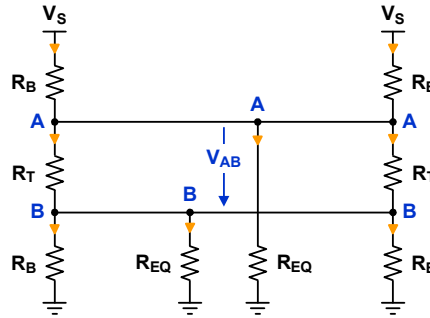

Figure 3. Lumped Equivalent Model for Dual Fail-Safe Biasing

The requirements for the termination resistors, R_T , are the same as for R_{T2} in the single fail-safe biasing network demanding that $Z_0 = 2R_B \parallel R_T$. Hence, for a given R_B , R_T must be:

$$R_T = \frac{2R_B \cdot Z_0}{2R_B - Z_0} \quad (\text{EQ. 8})$$

The condition for common-mode loading however, changes because each conductor now sees two biasing resistors in parallel to ground. Thus, the parallel combination of $R_B/2$ and R_{EQ} needs to be greater or equal to R_{CM} : $R_B/2 \parallel R_{EQ} \geq R_{CM}$. Hence, for a given R_B value, R_{EQ} is limited to:

$$R_{EQ} = \frac{R_B \cdot R_{CM}}{R_B - 2R_{CM}} \quad (\text{EQ. 9})$$

To find the equation for R_B we determine the node currents into A and B. Because the biasing networks are identical, they drive the same amount of current through R_{EQ} . We therefore have to establish only one current through R_{EQ} and multiply it by a factor of two to determine V_{AB} in the middle of the bus.

$$\text{Node A) } \frac{V_A}{R_{EQ}} = 2 \left(\frac{V_S - V_A}{R_B} - \frac{V_{AB}}{R_T} \right) \quad \text{Node B) } \frac{V_B}{R_{EQ}} = 2 \left(\frac{V_{AB}}{R_T} - \frac{V_B}{R_B} \right)$$

Solving the node currents for the individual line voltages, V_A and V_B , and calculating the difference between them, provides the differential bus voltage with:

$$V_{AB} = 2R_{EQ} \left[\frac{V_S}{R_B} - V_{AB} \left(\frac{1}{R_B} + \frac{2}{R_T} \right) \right] \quad (\text{EQ. 10})$$

Inserting EQs. 8, and 9 into (EQ. 10) provides the final equation for V_{AB} with:

$$V_{AB} = \frac{V_S}{\frac{R_B}{2} \left(\frac{1}{R_{CM}} + \frac{4}{Z_0} \right) - \frac{1}{2}} \quad (\text{EQ. 11})$$

And solving for R_B yields the minimum required bias resistor value with:

$$R_B \geq \frac{2V_S/V_{AB} + 1}{1/R_{CM} + 4/Z_0} \quad (\text{EQ. 12})$$

With R_B in place the maximum number of transceiver unit loads can now be calculated via:

$$n_{UL} = 12k\Omega \cdot \left(\frac{1}{R_{CM}} + \frac{2}{R_B} \right) \quad (\text{EQ. 13})$$

4.1 Calculation Examples

In the following examples we calculate the resistor values for the single and dual fail-safe biasing networks of a short and a long data link assuming a characteristic impedance of $Z_0 = 120\Omega$. The bus transceivers chosen are of the ISL8487E type. This device is a 1/8 UL transceiver with a minimum supply of $V_S = 4.75V$. Its maximum receiver input threshold is 200mV which, assuming a 100mV noise margin, requires an idle bus voltage of $V_{AB} = 300mV$.

Single Fail-Safe Network

(1) Make $R_{T1} = Z_0 = 120\Omega$

(2) Calculate R_B with (EQ. 6):

$$R_B \geq \frac{4.75V/0.3V + 1}{1/375\Omega + 4/120\Omega} = 467.6\Omega$$

Choose $R_B = 470\Omega$ from E-192 series of standard resistors.

(3) Calculate R_{T2} with (EQ. 2):

$$R_{T2} = \frac{2 \cdot 470\Omega \cdot 120\Omega}{2 \cdot 470\Omega - 120\Omega} = 137.6\Omega$$

Choose $R_{T2} = 138\Omega$ from E-192 series.

(4) Calculate n_{UL} with (EQ. 7):

$$n_{UL} = 12k\Omega \cdot \left(\frac{1}{375\Omega} - \frac{1}{470\Omega} \right) = 6.4 \text{ UL}$$

The maximum number of 1/8 UL transceivers is 6.4 UL / 1/8 UL = 51.

Dual Fail-Safe Network

(1) Calculate R_B with (EQ. 12):

$$R_B \geq \frac{2 \cdot 4.75V/0.3V + 1}{1/375\Omega + 4/120\Omega} = 907.4\Omega$$

Choose $R_B = 909\Omega$ from E-192 series.

(2) Calculate R_{T2} with (EQ. 2):

$$R_{T2} = \frac{2 \cdot 909\Omega \cdot 120\Omega}{2 \cdot 909\Omega - 120\Omega} = 128.5\Omega$$

Choose $R_{T2} = 129\Omega$ from E-192 series.

(3) Calculate n_{UL} with (EQ. 13):

$$n_{UL} = 12k\Omega \cdot \left(\frac{1}{375\Omega} - \frac{2}{909\Omega} \right) = 5.6 \text{ UL}$$

Here the maximum number of 1/8 UL transceivers is 5.6 UL / 1/8 UL = 44.

4.2 Transceiver Selection

Selecting the best transceiver with regard to noise immunity and output drive capability is important for robust network design for two reasons.

- (1) During times when the bus is not actively driven, there should be sufficient noise margin to prevent a receiver from false triggering even in very noisy environments.
- (2) During normal data transmission, the active driver must be able to drive the added common-mode load created by fail-safe biasing and still provide a signal with sufficient noise margin to remote transceivers.

Take the first generation ISL8487E, for example. The device has a positive receiver input threshold of $V_{IT-max} = 200mV$. Adding just a small noise margin of 50mV makes $V_{AB} = 200mV + 50mV = 250mV$.

Compare this to a second generation transceiver, such as the ISL83082E, with full fail-safe capability. Its receiver output turns high whether the receiver inputs are floating (bus open) or shorted (bus short or idle). Full fail-safe capability is accomplished by offsetting the maximum input threshold to a slightly negative level, in this case -50mV. To provide the same 50mV noise margin, a V_{AB} of 0V is sufficient, which eliminates the need for external fail-safe biasing. Without a biasing network, all 32 unit loads are available to bus transceivers.

In modern industrial applications with high electrical noise pollution however, industrial networks, such as Profibus, use dual fail-safe biasing with idle bus voltages of 0.6V and more. V_{AB} levels that high require the bias resistors to be of such low resistance that their combined value drops far below the minimum common-mode resistance of 375Ω. When this happens the calculation of n_{UL} will result in negative values. In fact, it is possible to calculate the maximum V_{AB} (when $n_{UL} = 0$) by making $R_B/2 = R_{CM}$ in (EQ. 12) and solving for V_{AB} :

$$V_{AB} = \frac{V_S \cdot Z_0}{4R_{CM}} = \frac{4.75V \cdot 120\Omega}{4 \cdot 375\Omega} = 0.38V \tag{EQ. 14}$$

Hence, networks requiring high V_{AB} levels need dedicated transceivers that provide much higher differential and common-mode drive capability than standard compliant transceivers.

One transceiver series meeting these demands is Intersil’s ISL315x family of large V_{OD} transceivers. These devices are capable of driving up to eight 120Ω terminations in parallel at a minimum differential output of $V_{OD-MIN} = 1.5V$, (Figure 4) and more than 60 DC-unit loads over a common-mode voltage range from -7V to +12V at a minimum V_{OD} of 2.4V (Figure 5).

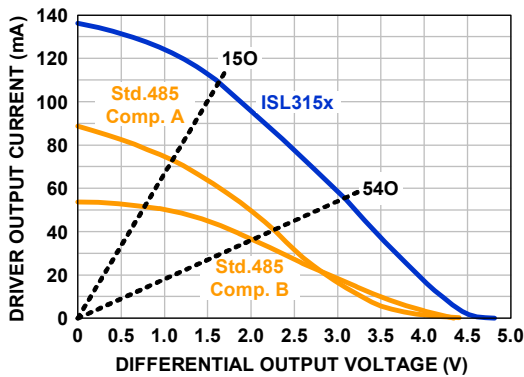

Figure 4. Differential Output Drive Capability: ISL315x vs Standard RS-485 Transceivers

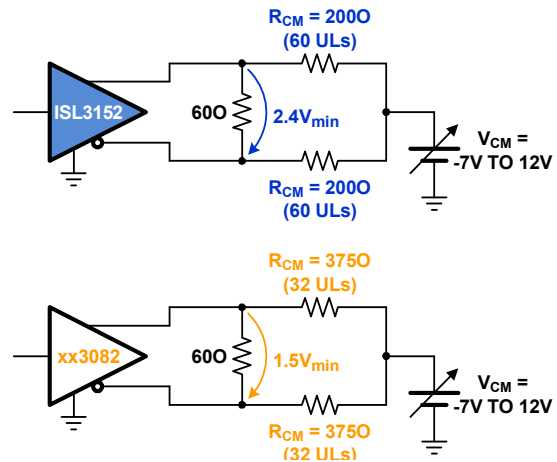

Figure 5. Common-Mode Output Drive Capability: ISL315x vs Standard RS-485 Transceivers

The ISL315x’s superior output drive capability provides enhanced noise immunity even to the most remote bus transceiver, while allowing for twice the common-mode loading of standard RS-485 transceivers.

Table 1 on page 9 lists the resistor values for single and dual fail-safe biasing networks and compares the available transceiver unit loads for two standard transceivers, ISL8487 and ISL83082, and the high- V_{OD} transceiver, ISL3152, as a function of noise margin.

Table 1. Resistor Values and ULs for Standard and High V_{OD} Transceivers as a Function of Noise Margin

| V_{NOISE} (mV) | 50 | | | 100 | | | 300 | | 600 | 800 |
|---|---------|----------|----------|---------|----------|---------|----------|---------|---------|---------|
| Device | ISL8487 | ISL83082 | ISL3152 | ISL8487 | ISL83082 | ISL3152 | ISL83082 | ISL3152 | ISL3152 | ISL3152 |
| V_{IT-MAX} (mV) | 200 | -50 | -50 | 200 | -50 | -50 | -50 | -50 | -50 | -50 |
| V_{AB} (V) | 250 | 0 | 0 | 300 | 50 | 50 | 250 | 250 | 550 | 750 |
| R_{T1}, Z_0 (Ω) | 120 | 120 | 120 | 120 | 120 | 120 | 120 | 120 | 120 | 150 |
| R_{CM} (Ω) | 375 | 375 | 200 | 375 | 375 | 200 | 375 | 200 | 200 | 200 |
| Single Fail-Safe Biasing | | | | | | | | | | |
| R_B (Ω) | 556 | ∞ | ∞ | 470 | 2670 | 2520 | 556 | 523 | 252 | 232 |
| R_{T2} (Ω) | 135 | 120 | 120 | 138 | 123 | 123 | 135 | 137 | 158 | 249 |
| Dual Fail-Safe Biasing | | | | | | | | | | |
| R_B (Ω) | 1110 | ∞ | ∞ | 942 | 5360 | 5110 | 1110 | 1050 | 505 | 463 |
| R_T (Ω) | 127 | 120 | 120 | 129 | 121 | 121 | 127 | 127 | 137 | 180 |
| Transceiver Count and Unit Loads | | | | | | | | | | |
| n_{UL} | 10.4 | 32 | 60 | 6.5 | 27.5 | 55.3 | 10.4 | 37.1 | 12.5 | 8.2 |
| n_{TX} | 83 | 256 | 480 | 52 | 220 | 442 | 83 | 297 | 99 | 65 |

Transceivers with a 200mV input threshold, such as the ISL8487, allow only for low idle-bus noise margins of up to 100mV. Beyond that, the required rise in V_{AB} demands the bias resistor values to be so low that the resulting numbers in transceiver unit loads turns negative.

Full fail-safe transceivers, such as the ISL83082, require much lower V_{AB} values due to their negative input threshold of -50mV. This allows for much higher bias resistor values and consequently higher numbers in bus transceivers.

Both transceiver types however, have a standard drive capability of up to 32 unit loads, which limits their use in noisy environments to networks with mediocre noise margins and low transceiver counts.

In strong contrast, the ISL3152 with its high V_{OD} easily drives more than twice the transceiver count at medium noise levels and still manages to support up to 100 transceivers at 600mV noise margin. To accomplish even higher noise margins, an increase in the characteristic cable impedance is necessary. This is done in Profibus where $Z_0 = 150\Omega$, thus necessitating higher values for R_T and R_B to lower common-mode loading of the biasing networks.

5. Conclusion

Fail-safe biasing networks ensure stable network node operation during periods of time when the bus is not actively driven. The additional common-mode loading caused by the bias resistors must be driven by an active driver during normal data transmission. The high noise margins required in industrial networks demand low bias resistor values whose common-mode load can overburden the drive capability of standard RS-485 transceivers.

To alleviate this problem Intersil has released the ISL315x family of large output voltage swing transceivers, capable of driving up to eight 120Ω terminations and more than 60 DC-unit loads. In combination with the equations provided in this application note, these transceivers ease and accelerate the design of fail-safe biasing networks.

The ISL315x transceivers are available in half- and full-duplex versions and with speed grades of 0.115, 1, and 20Mbps. The devices come with $\pm 16\text{kV}$ IEC61000 ESD protection on the bus pins, high transient overvoltage tolerance of up to 100V, hot plug capability, slew-rate limiting, and ultra-low shutdown mode of 70nA.

6. Revision History

| Rev. | Date | Description |
|------|--------------|---|
| 1.00 | Aug 3, 2017 | Updated Equations 11, 12, and 13. Removed Note under Equation 13. Updated the calculated examples. Added Revision History. |
| 0.00 | Apr 28, 2017 | Initial release |

Notice

1. Descriptions of circuits, software and other related information in this document are provided only to illustrate the operation of semiconductor products and application examples. You are fully responsible for the incorporation or any other use of the circuits, software, and information in the design of your product or system. Renesas Electronics disclaims any and all liability for any losses and damages incurred by you or third parties arising from the use of these circuits, software, or information.
2. Renesas Electronics hereby expressly disclaims any warranties against and liability for infringement or any other claims involving patents, copyrights, or other intellectual property rights of third parties, by or arising from the use of Renesas Electronics products or technical information described in this document, including but not limited to, the product data, drawings, charts, programs, algorithms, and application examples.
3. No license, express, implied or otherwise, is granted hereby under any patents, copyrights or other intellectual property rights of Renesas Electronics or others.
4. You shall not alter, modify, copy, or reverse engineer any Renesas Electronics product, whether in whole or in part. Renesas Electronics disclaims any and all liability for any losses or damages incurred by you or third parties arising from such alteration, modification, copying or reverse engineering.
5. Renesas Electronics products are classified according to the following two quality grades: "Standard" and "High Quality". The intended applications for each Renesas Electronics product depends on the product's quality grade, as indicated below.
"Standard": Computers; office equipment; communications equipment; test and measurement equipment; audio and visual equipment; home electronic appliances; machine tools; personal electronic equipment; industrial robots; etc.
"High Quality": Transportation equipment (automobiles, trains, ships, etc.); traffic control (traffic lights); large-scale communication equipment; key financial terminal systems; safety control equipment; etc.
Unless expressly designated as a high reliability product or a product for harsh environments in a Renesas Electronics data sheet or other Renesas Electronics document, Renesas Electronics products are not intended or authorized for use in products or systems that may pose a direct threat to human life or bodily injury (artificial life support devices or systems; surgical implantations; etc.), or may cause serious property damage (space system; undersea repeaters; nuclear power control systems; aircraft control systems; key plant systems; military equipment; etc.). Renesas Electronics disclaims any and all liability for any damages or losses incurred by you or any third parties arising from the use of any Renesas Electronics product that is inconsistent with any Renesas Electronics data sheet, user's manual or other Renesas Electronics document.
6. When using Renesas Electronics products, refer to the latest product information (data sheets, user's manuals, application notes, "General Notes for Handling and Using Semiconductor Devices" in the reliability handbook, etc.), and ensure that usage conditions are within the ranges specified by Renesas Electronics with respect to maximum ratings, operating power supply voltage range, heat dissipation characteristics, installation, etc. Renesas Electronics disclaims any and all liability for any malfunctions, failure or accident arising out of the use of Renesas Electronics products outside of such specified ranges.
7. Although Renesas Electronics endeavors to improve the quality and reliability of Renesas Electronics products, semiconductor products have specific characteristics, such as the occurrence of failure at a certain rate and malfunctions under certain use conditions. Unless designated as a high reliability product or a product for harsh environments in a Renesas Electronics data sheet or other Renesas Electronics document, Renesas Electronics products are not subject to radiation resistance design. You are responsible for implementing safety measures to guard against the possibility of bodily injury, injury or damage caused by fire, and/or danger to the public in the event of a failure or malfunction of Renesas Electronics products, such as safety design for hardware and software, including but not limited to redundancy, fire control and malfunction prevention, appropriate treatment for aging degradation or any other appropriate measures. Because the evaluation of microcomputer software alone is very difficult and impractical, you are responsible for evaluating the safety of the final products or systems manufactured by you.
8. Please contact a Renesas Electronics sales office for details as to environmental matters such as the environmental compatibility of each Renesas Electronics product. You are responsible for carefully and sufficiently investigating applicable laws and regulations that regulate the inclusion or use of controlled substances, including without limitation, the EU RoHS Directive, and using Renesas Electronics products in compliance with all these applicable laws and regulations. Renesas Electronics disclaims any and all liability for damages or losses occurring as a result of your noncompliance with applicable laws and regulations.
9. Renesas Electronics products and technologies shall not be used for or incorporated into any products or systems whose manufacture, use, or sale is prohibited under any applicable domestic or foreign laws or regulations. You shall comply with any applicable export control laws and regulations promulgated and administered by the governments of any countries asserting jurisdiction over the parties or transactions.
10. It is the responsibility of the buyer or distributor of Renesas Electronics products, or any other party who distributes, disposes of, or otherwise sells or transfers the product to a third party, to notify such third party in advance of the contents and conditions set forth in this document.
11. This document shall not be reprinted, reproduced or duplicated in any form, in whole or in part, without prior written consent of Renesas Electronics.
12. Please contact a Renesas Electronics sales office if you have any questions regarding the information contained in this document or Renesas Electronics products.
(Note 1) "Renesas Electronics" as used in this document means Renesas Electronics Corporation and also includes its directly or indirectly controlled subsidiaries.
(Note 2) "Renesas Electronics product(s)" means any product developed or manufactured by or for Renesas Electronics.

(Rev.4.0-1 November 2017)



SALES OFFICES

Renesas Electronics Corporation

<http://www.renesas.com>

Refer to "<http://www.renesas.com/>" for the latest and detailed information.

Renesas Electronics America Inc.
1001 Murphy Ranch Road, Milpitas, CA 95035, U.S.A.
Tel: +1-408-432-8888, Fax: +1-408-434-5351

Renesas Electronics Canada Limited
9251 Yonge Street, Suite 8309 Richmond Hill, Ontario Canada L4C 9T3
Tel: +1-905-237-2004

Renesas Electronics Europe Limited
Dukes Meadow, Millboard Road, Bourne End, Buckinghamshire, SL8 5FH, U.K
Tel: +44-1628-651-700, Fax: +44-1628-651-804

Renesas Electronics Europe GmbH
Arcadiastrasse 10, 40472 Düsseldorf, Germany
Tel: +49-211-6503-0, Fax: +49-211-6503-1327

Renesas Electronics (China) Co., Ltd.
Room 1709 Quantum Plaza, No.27 ZhichunLu, Haidian District, Beijing, 100191 P. R. China
Tel: +86-10-8235-1155, Fax: +86-10-8235-7679

Renesas Electronics (Shanghai) Co., Ltd.
Unit 301, Tower A, Central Towers, 555 Langao Road, Putuo District, Shanghai, 200333 P. R. China
Tel: +86-21-2226-0888, Fax: +86-21-2226-0999

Renesas Electronics Hong Kong Limited
Unit 1601-1611, 16/F., Tower 2, Grand Century Place, 193 Prince Edward Road West, Mongkok, Kowloon, Hong Kong
Tel: +852-2265-6688, Fax: +852-2886-9022

Renesas Electronics Taiwan Co., Ltd.
13F, No. 363, Fu Shing North Road, Taipei 10543, Taiwan
Tel: +886-2-8175-9600, Fax: +886-2-8175-9670

Renesas Electronics Singapore Pte. Ltd.
80 Bendemeer Road, Unit #06-02 Hyflux Innovation Centre, Singapore 339949
Tel: +65-6213-0200, Fax: +65-6213-0300

Renesas Electronics Malaysia Sdn.Bhd.
Unit 1207, Block B, Menara Amcorp, Amcorp Trade Centre, No. 18, Jln Persiaran Barat, 46050 Petaling Jaya, Selangor Darul Ehsan, Malaysia
Tel: +60-3-7955-9390, Fax: +60-3-7955-9510

Renesas Electronics India Pvt. Ltd.
No.777C, 100 Feet Road, HAL 2nd Stage, Indiranagar, Bangalore 560 038, India
Tel: +91-80-67208700, Fax: +91-80-67208777

Renesas Electronics Korea Co., Ltd.
17F, KAMCO Yangjae Tower, 262, Gangnam-daero, Gangnam-gu, Seoul, 06265 Korea
Tel: +82-2-558-3737, Fax: +82-2-558-5338