

Abstract

Today's telecom, datacom and computing environments are delivering more power than ever and requiring less space for the DC/DC conversion. Intersil has numerous power management reference designs for POL conversion in the smallest space available. Designers can take the schematic, BOM (Bill of Materials) layout information and apply it directly to their present design, saving them time and money.

As with every benefit there are tradeoffs. In this case, the tradeoff is access to testing. Since there are limited places to probe on the board, special techniques must be implemented when using small form factor evaluation boards. In this paper we will discuss some of these techniques.

Table of Contents

Introduction 2

Application Example 2

 Simplified Schematic Connection 3

 Traditional Method for Lab Measurements 3

Application Example 5

 New Interconnect System 5

 High Frequency Scope Connection 6

New High Frequency Interconnect Method 7

Performance Comparison 8

Summary 8

List of Figures

FIGURE 1. Intersil Small Form Factor Evaluation Boards 2

FIGURE 2. ISL8002B Demonstration Board 2

FIGURE 3. ISL8002B Tracking Start-up 2

FIGURE 4. Simplified Schematic Connection 3

FIGURE 5. Traditional Method for Lab Measurements 3

FIGURE 6. New Connector System 4

FIGURE 7. 64 Pin Solder Tail 4

FIGURE 8. New Interconnect System 5

FIGURE 9. Detailed View Showing Interconnects and DMM Connection on the Master 5

FIGURE 10. Detailed View Showing Interconnects and DMM Connection on the Slave 6

FIGURE 11. Connector Socket Receptacle 6

FIGURE 12. Ground Connection 6

FIGURE 13. CT2714 Oscilloscope Probe Tip Ground 6

FIGURE 14. Connection Using New High Frequency Interconnect Method 7

FIGURE 15. Traditional Scope Connection 7

FIGURE 16. Traditional Scope Probe Method 8

FIGURE 17. Interconnect Scope Probe Method 8

Introduction

As you can see, most of the evaluation boards are about a ½" on a side. Intersil small reference designs mentioned here are listed below, but not limited to the following part numbers: ISL85410, ISL85413, ISL85415, ISL85418, ISL85403, ISL85412, ISL8033, ISL85003A, ISL8002B, ISL8016, ISL8023 and ISL8024.

Intersil small form factor evaluation boards, great size but challenging to validate the design.

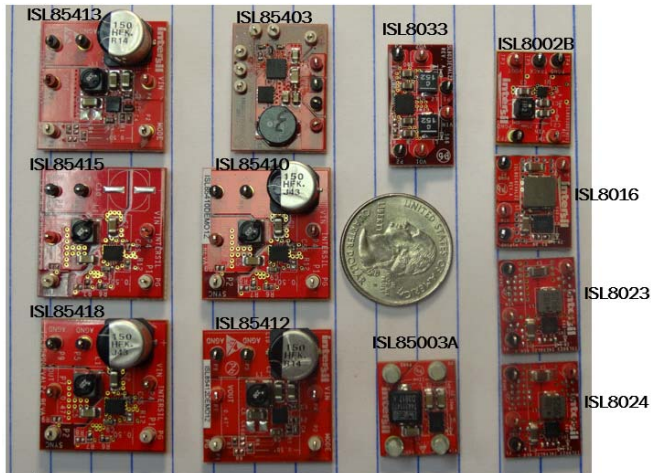

FIGURE 1. INTERSIL SMALL FORM FACTOR EVALUATION BOARDS

Application Example

Coincidental voltage tracking using two ISL8002B demonstration boards. Showing the issues with a small form factor board.

Tracking is easy to accomplish by connecting a feedback resistor network, R_3 and R_4 from V_{OUT} of the master (m) to the SS/TR2 pin of the slave (s) with the same ratio of R_1 and R_2 that sets the V_{OUT} voltage of the slave device. Note: the ISL8002B demonstration board already has this resistor divider included for the default output voltage. Therefore, the V_{OUT} (TP3) from the master device needs to be connected directly to the TRK/SS pin (TP5) of the slave device.

1. Connect the positive terminal of PS#1 to VIN (TP1) and negative terminal to PGND (TP2) for BOTH master board and slave board.
2. Connect positive (+) terminal of PS#2 to TRK/SS pin (TP5) and negative terminal to PGND on the master boards. (Set the soft-start and enable for master board.)
3. Connect V_{OUT} of master board to TRK/SS pin of slave board.
4. Connect one channel of the oscilloscope to V_{OUT} of master board. Connect another channel of the oscilloscope to the slave board. Trigger the master channel for ONE SHOT on the RISING EDGE.
5. Turn on PS#1 to give power to both boards.
6. Turn on PS#2 to enable the master board. Observe the oscilloscope capture of slave tracking master output. The slave device V_{OUT} will rise with the master device V_{OUT} to respective voltages. If both boards are default, the output voltages will match (1.8V).

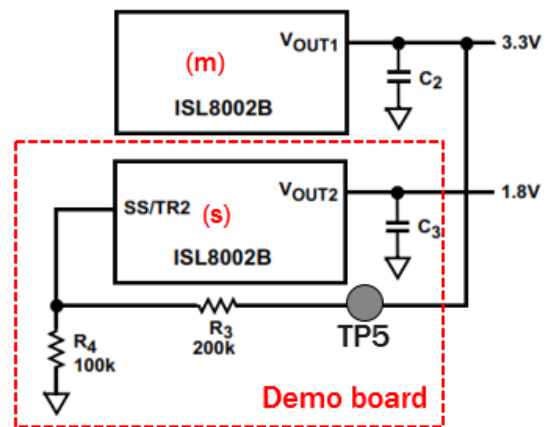

FIGURE 2. ISL8002B DEMONSTRATION BOARD

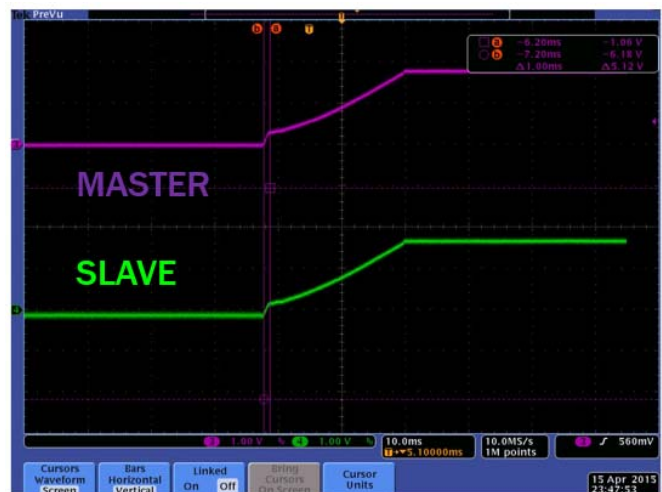

FIGURE 3. ISL8002B TRACKING START-UP

Simplified Schematic Connection

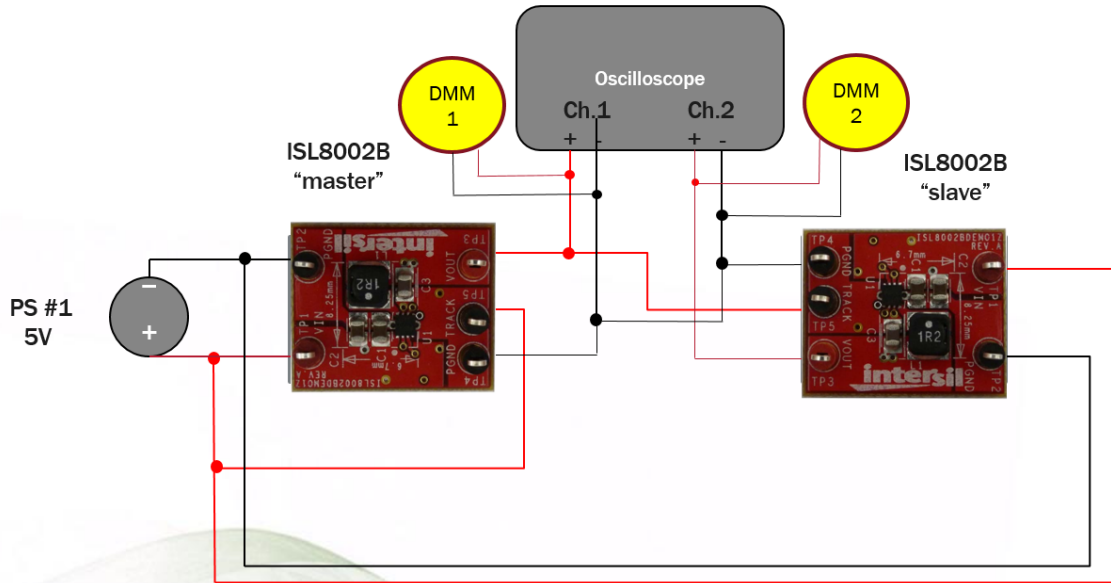

FIGURE 4. SIMPLIFIED SCHEMATIC CONNECTION

Traditional Method for Lab Measurements

PROBLEM: Board is not big enough for all the connections; VIN, VOUT, GND and Tracking. There are 23 connections needed for measuring the output voltage tracking capability.

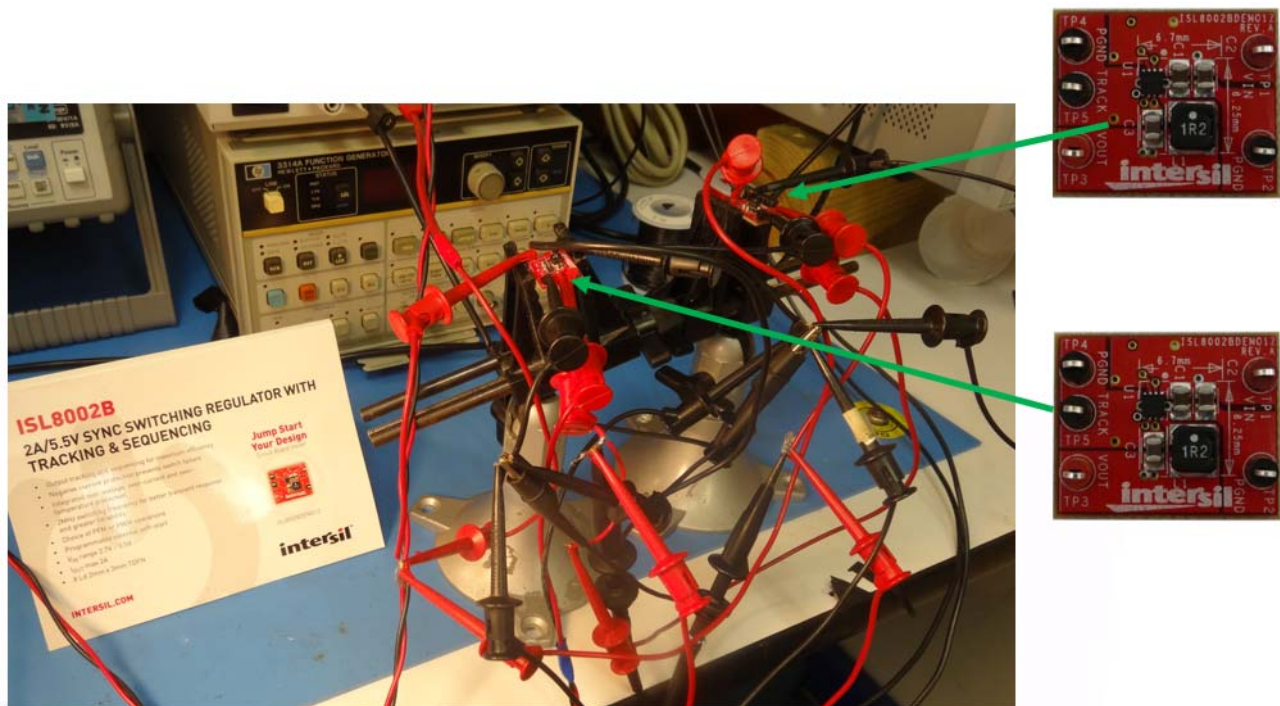

FIGURE 5. TRADITIONAL METHOD FOR LAB MEASUREMENTS

SOLUTION: Build a new connector system using a 18-20 gauge wire with a 64 pin strip socket solder tail. This reduces the number of connections to 8.

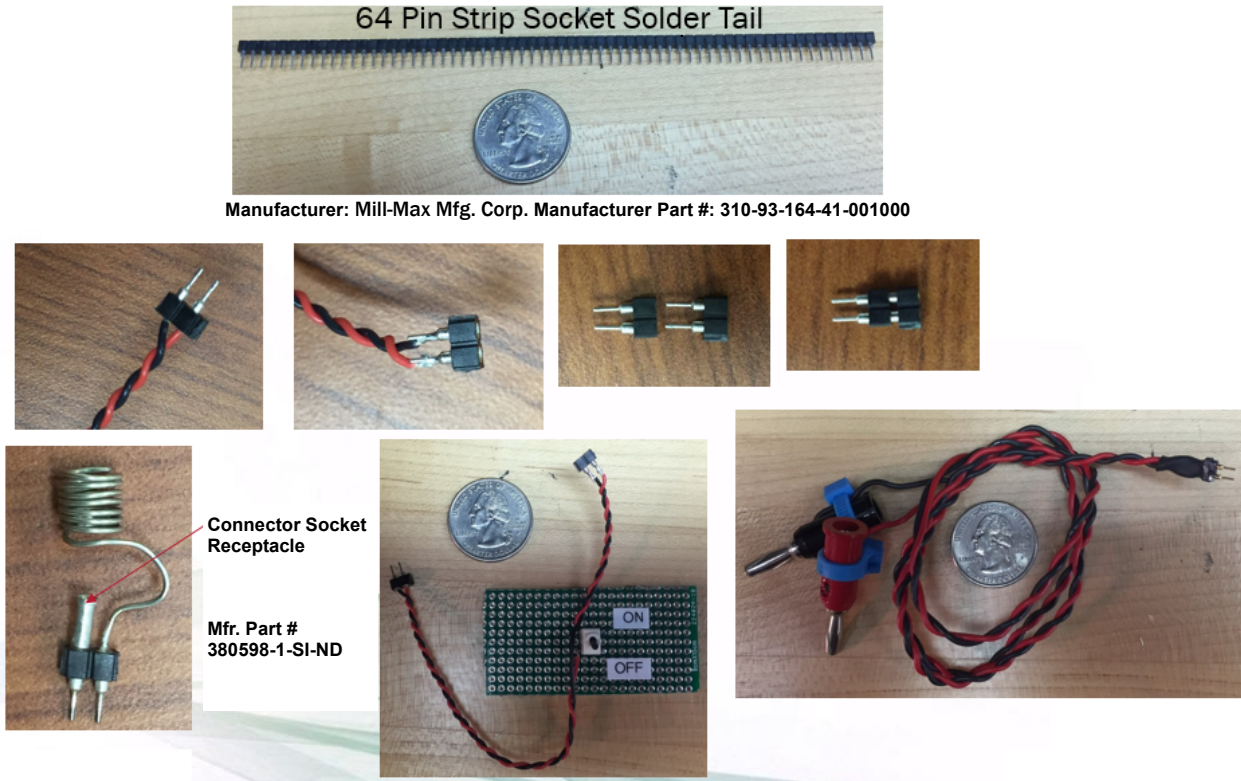

FIGURE 6. NEW CONNECTOR SYSTEM



FIGURE 7. 64 PIN SOLDER TAIL

NOTE: The 64 pin solder tails snap apart to any length needed.

Application Example

New Interconnect System

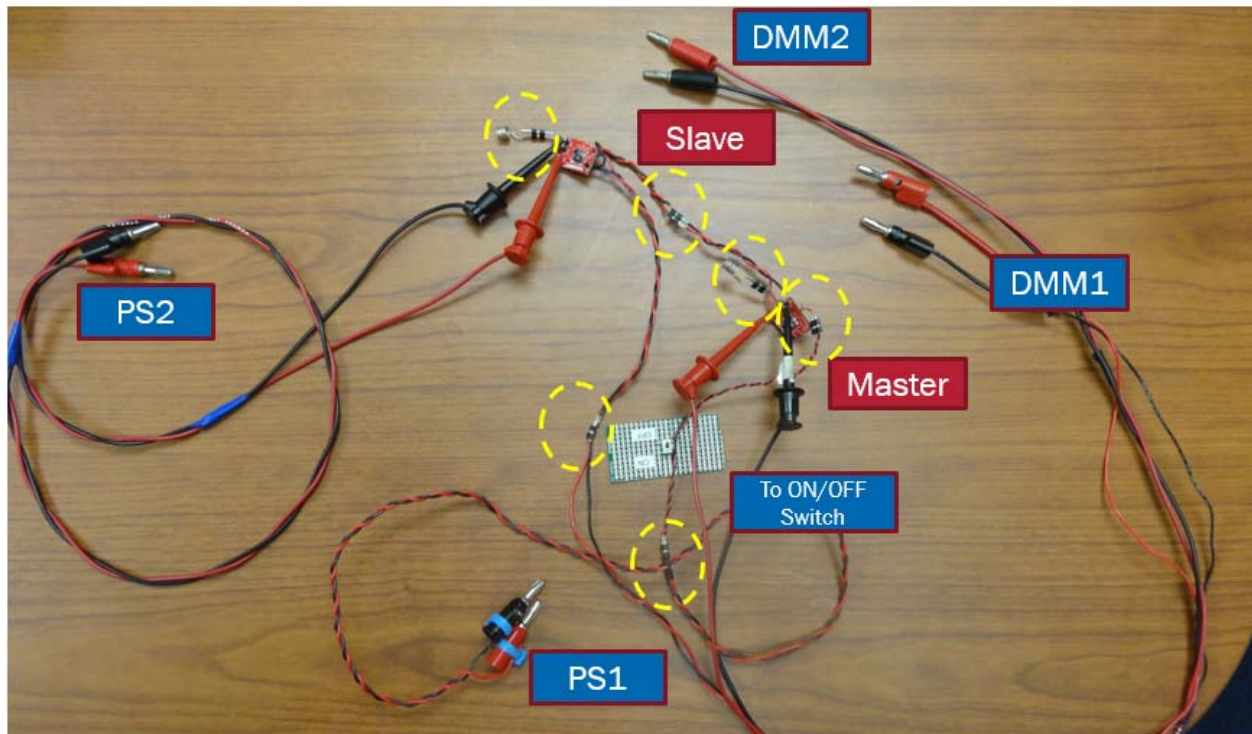

FIGURE 8. NEW INTERCONNECT SYSTEM

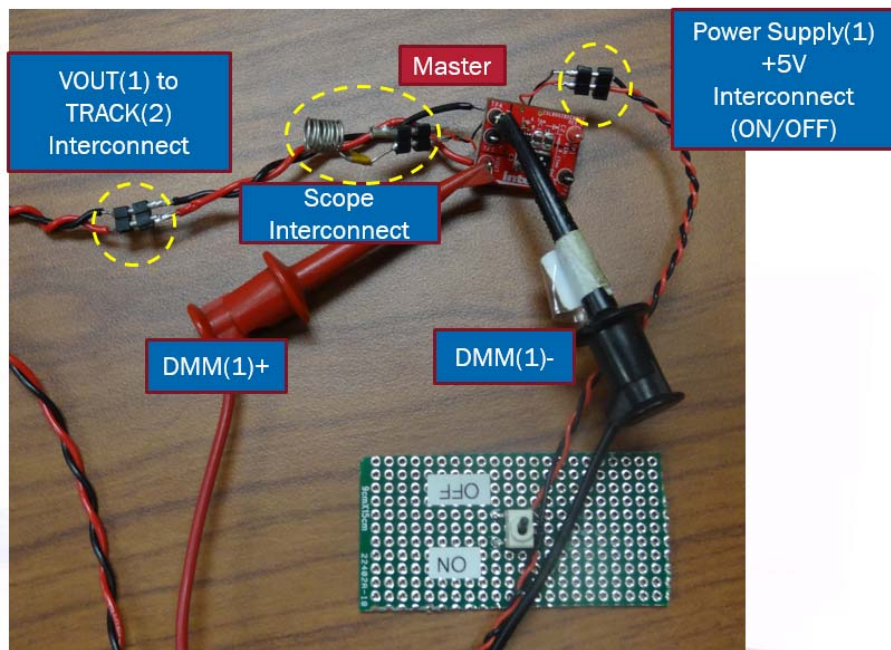

FIGURE 9. DETAILED VIEW SHOWING INTERCONNECTS AND DMM CONNECTION ON THE MASTER

New Interconnect System (Continued)

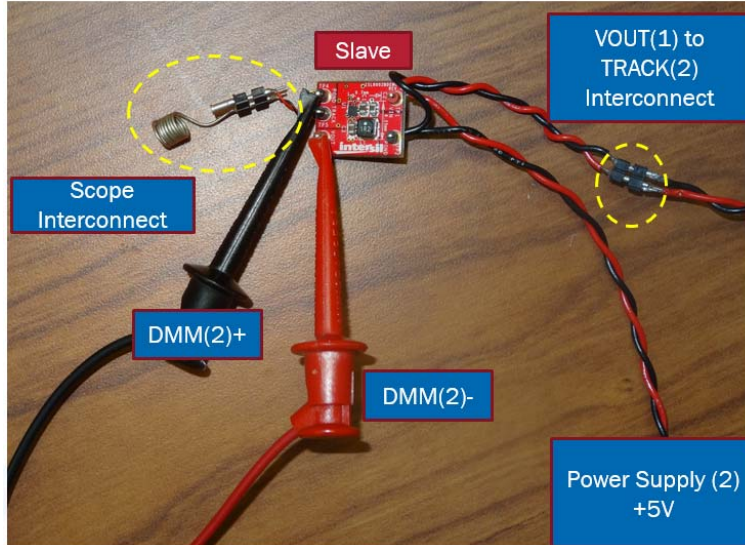

FIGURE 10. DETAILED VIEW SHOWING INTERCONNECTS AND DMM CONNECTION ON THE SLAVE

High Frequency Scope Connection

Creating a high frequency scope connection minimizes noise induced in the output waveform. Using the same strip socket for the interconnections, use a receptacle listed in [Figure 11](#) in one of the sockets and the other to create a ground connection. The ground connection can be made from a solid wire wrapped around the scope probe (see [Figure 12](#)) or order one from [Cal Test Electronics](#) ([Figure 13](#)).



FIGURE 12. GROUND CONNECTION



Connector Socket Receptacle
Mfr: TE Connectivity
Mfr. Part # 380598-1-SI-ND



FIGURE 11. CONNECTOR SOCKET RECEPTACLE



Mfr: Cal Test Electronics
Mfr. Part # CT2714

Oscilloscope probe tip ground compatible with most 5mm scope probes. 5mm probe accessories.

FIGURE 13. CT2714 OSCILLOSCOPE PROBE TIP GROUND

New High Frequency Interconnect Method



FIGURE 14. CONNECTION USING NEW HIGH FREQUENCY INTERCONNECT METHOD



FIGURE 15. TRADITIONAL SCOPE CONNECTION

Performance Comparison

A different evaluation board was used to help show the difference between the two different scope connections. The boards used in [Figures 16](#) and [17](#) had a 10A load step with VOUT AC coupled.

Summary

In this paper a low cost, highly effective method was introduced to help the designer analyze his design with the small form factor evaluation boards from Intersil. One thing to note is that this method is targeted for low power circuit analysis (PGOOD signal generation, sequencing and other timing validation) and not intended for full load efficiency testing because of the small gauge wire and the interconnect system.

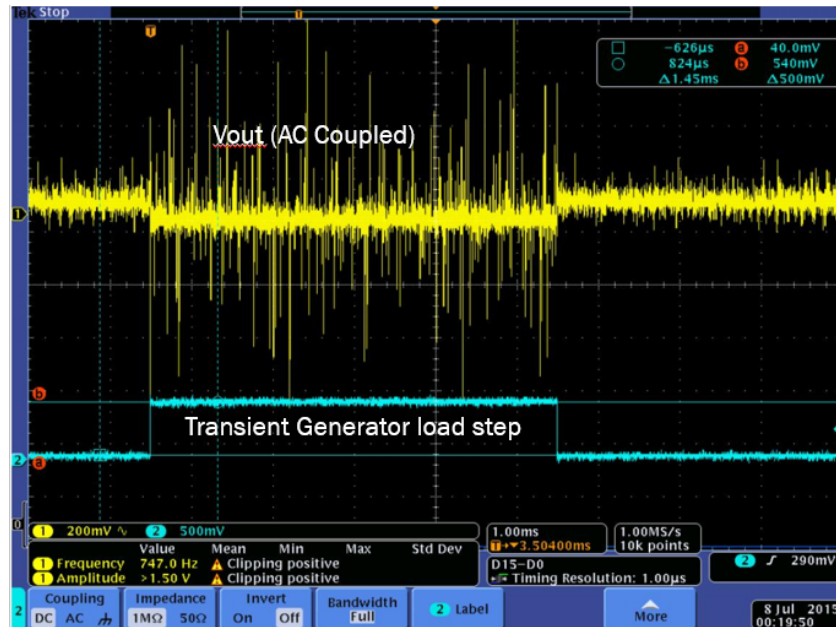

FIGURE 16. TRADITIONAL SCOPE PROBE METHOD

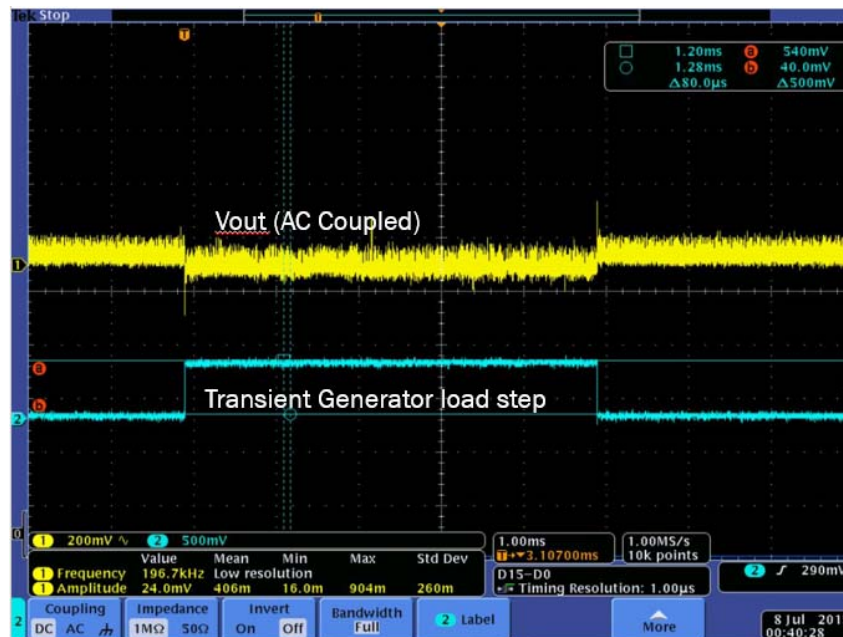

FIGURE 17. INTERCONNECT SCOPE PROBE METHOD

Notice

1. Descriptions of circuits, software and other related information in this document are provided only to illustrate the operation of semiconductor products and application examples. You are fully responsible for the incorporation or any other use of the circuits, software, and information in the design of your product or system. Renesas Electronics disclaims any and all liability for any losses and damages incurred by you or third parties arising from the use of these circuits, software, or information.
2. Renesas Electronics hereby expressly disclaims any warranties against and liability for infringement or any other claims involving patents, copyrights, or other intellectual property rights of third parties, by or arising from the use of Renesas Electronics products or technical information described in this document, including but not limited to, the product data, drawings, charts, programs, algorithms, and application examples.
3. No license, express, implied or otherwise, is granted hereby under any patents, copyrights or other intellectual property rights of Renesas Electronics or others.
4. You shall not alter, modify, copy, or reverse engineer any Renesas Electronics product, whether in whole or in part. Renesas Electronics disclaims any and all liability for any losses or damages incurred by you or third parties arising from such alteration, modification, copying or reverse engineering.
5. Renesas Electronics products are classified according to the following two quality grades: "Standard" and "High Quality". The intended applications for each Renesas Electronics product depends on the product's quality grade, as indicated below.
"Standard": Computers; office equipment; communications equipment; test and measurement equipment; audio and visual equipment; home electronic appliances; machine tools; personal electronic equipment; industrial robots; etc.
"High Quality": Transportation equipment (automobiles, trains, ships, etc.); traffic control (traffic lights); large-scale communication equipment; key financial terminal systems; safety control equipment; etc.
Unless expressly designated as a high reliability product or a product for harsh environments in a Renesas Electronics data sheet or other Renesas Electronics document, Renesas Electronics products are not intended or authorized for use in products or systems that may pose a direct threat to human life or bodily injury (artificial life support devices or systems; surgical implantations; etc.), or may cause serious property damage (space system; undersea repeaters; nuclear power control systems; aircraft control systems; key plant systems; military equipment; etc.). Renesas Electronics disclaims any and all liability for any damages or losses incurred by you or any third parties arising from the use of any Renesas Electronics product that is inconsistent with any Renesas Electronics data sheet, user's manual or other Renesas Electronics document.
6. When using Renesas Electronics products, refer to the latest product information (data sheets, user's manuals, application notes, "General Notes for Handling and Using Semiconductor Devices" in the reliability handbook, etc.), and ensure that usage conditions are within the ranges specified by Renesas Electronics with respect to maximum ratings, operating power supply voltage range, heat dissipation characteristics, installation, etc. Renesas Electronics disclaims any and all liability for any malfunctions, failure or accident arising out of the use of Renesas Electronics products outside of such specified ranges.
7. Although Renesas Electronics endeavors to improve the quality and reliability of Renesas Electronics products, semiconductor products have specific characteristics, such as the occurrence of failure at a certain rate and malfunctions under certain use conditions. Unless designated as a high reliability product or a product for harsh environments in a Renesas Electronics data sheet or other Renesas Electronics document, Renesas Electronics products are not subject to radiation resistance design. You are responsible for implementing safety measures to guard against the possibility of bodily injury, injury or damage caused by fire, and/or danger to the public in the event of a failure or malfunction of Renesas Electronics products, such as safety design for hardware and software, including but not limited to redundancy, fire control and malfunction prevention, appropriate treatment for aging degradation or any other appropriate measures. Because the evaluation of microcomputer software alone is very difficult and impractical, you are responsible for evaluating the safety of the final products or systems manufactured by you.
8. Please contact a Renesas Electronics sales office for details as to environmental matters such as the environmental compatibility of each Renesas Electronics product. You are responsible for carefully and sufficiently investigating applicable laws and regulations that regulate the inclusion or use of controlled substances, including without limitation, the EU RoHS Directive, and using Renesas Electronics products in compliance with all these applicable laws and regulations. Renesas Electronics disclaims any and all liability for damages or losses occurring as a result of your noncompliance with applicable laws and regulations.
9. Renesas Electronics products and technologies shall not be used for or incorporated into any products or systems whose manufacture, use, or sale is prohibited under any applicable domestic or foreign laws or regulations. You shall comply with any applicable export control laws and regulations promulgated and administered by the governments of any countries asserting jurisdiction over the parties or transactions.
10. It is the responsibility of the buyer or distributor of Renesas Electronics products, or any other party who distributes, disposes of, or otherwise sells or transfers the product to a third party, to notify such third party in advance of the contents and conditions set forth in this document.
11. This document shall not be reprinted, reproduced or duplicated in any form, in whole or in part, without prior written consent of Renesas Electronics.
12. Please contact a Renesas Electronics sales office if you have any questions regarding the information contained in this document or Renesas Electronics products.
(Note 1) "Renesas Electronics" as used in this document means Renesas Electronics Corporation and also includes its directly or indirectly controlled subsidiaries.
(Note 2) "Renesas Electronics product(s)" means any product developed or manufactured by or for Renesas Electronics.

(Rev.4.0-1 November 2017)



SALES OFFICES

Renesas Electronics Corporation

<http://www.renesas.com>

Refer to "<http://www.renesas.com/>" for the latest and detailed information.

Renesas Electronics America Inc.
1001 Murphy Ranch Road, Milpitas, CA 95035, U.S.A.
Tel: +1-408-432-8888, Fax: +1-408-434-5351

Renesas Electronics Canada Limited
9251 Yonge Street, Suite 8309 Richmond Hill, Ontario Canada L4C 9T3
Tel: +1-905-237-2004

Renesas Electronics Europe Limited
Dukes Meadow, Millboard Road, Bourne End, Buckinghamshire, SL8 5FH, U.K.
Tel: +44-1628-651-700, Fax: +44-1628-651-804

Renesas Electronics Europe GmbH
Arcadiastrasse 10, 40472 Düsseldorf, Germany
Tel: +49-211-6503-0, Fax: +49-211-6503-1327

Renesas Electronics (China) Co., Ltd.
Room 1709 Quantum Plaza, No.27 ZhichunLu, Haidian District, Beijing, 100191 P. R. China
Tel: +86-10-8235-1155, Fax: +86-10-8235-7679

Renesas Electronics (Shanghai) Co., Ltd.
Unit 301, Tower A, Central Towers, 555 Langao Road, Putuo District, Shanghai, 200333 P. R. China
Tel: +86-21-2226-0888, Fax: +86-21-2226-0999

Renesas Electronics Hong Kong Limited
Unit 1601-1611, 16/F., Tower 2, Grand Century Place, 193 Prince Edward Road West, Mongkok, Kowloon, Hong Kong
Tel: +852-2265-6688, Fax: +852-2886-9022

Renesas Electronics Taiwan Co., Ltd.
13F, No. 363, Fu Shing North Road, Taipei 10543, Taiwan
Tel: +886-2-8175-9600, Fax: +886-2-8175-9670

Renesas Electronics Singapore Pte. Ltd.
80 Bendemeer Road, Unit #06-02 Hyflux Innovation Centre, Singapore 339949
Tel: +65-6213-0200, Fax: +65-6213-0300

Renesas Electronics Malaysia Sdn.Bhd.
Unit 1207, Block B, Menara Amcorp, Amcorp Trade Centre, No. 18, Jln Persiaran Barat, 46050 Petaling Jaya, Selangor Darul Ehsan, Malaysia
Tel: +60-3-7955-9390, Fax: +60-3-7955-9510

Renesas Electronics India Pvt. Ltd.
No.777C, 100 Feet Road, HAL 2nd Stage, Indiranagar, Bangalore 560 038, India
Tel: +91-80-67208700, Fax: +91-80-67208777

Renesas Electronics Korea Co., Ltd.
17F, KAMCO Yangjae Tower, 262, Gangnam-daero, Gangnam-gu, Seoul, 06265 Korea
Tel: +82-2-558-3737, Fax: +82-2-558-5338