

Introduction

Ambient Light Sensors have become widely established components in digital display products. Virtually every contemporary flat display, regardless of backlighting approach, implements ambient light sensing to facilitate display brightness control. While dynamic display brightness control improves display viewability and reduces user eye-strain, more significantly it enables extended battery operational life in mobile devices.

The ambient light sensing function may be implemented using discrete components, such as silicon photodetectors and transimpedance (current-to-voltage) amplifiers. However, fully integrated, mixed-signal sensor devices are more common in backlit digital displays. Many ambient light sensors work quite well, others do not. However, more often than not, it is not the sensor device that performs inadequately; it is the optical/mechanical implementation in the display product that is at fault.

An ambient light sensor is an opto-electronic device - it has two separate but, equally important interfaces: electrical and optical. Inattention to either interface will reduce performance and possibly lead to functional failure under certain conditions. Just as device functionality depends on proper electrical connections and signal characteristics, the sensor also must be provided with proper optical paths and optical signals. It is through the optical/mechanical product design that proper optical signal paths and signal integrity are implemented.

Typically, product designers do not want the user to be aware of the ambient light sensor or its location, during normal use. Therefore, the sensor frequently is located under heavily tinted glass - allowing only a small fraction (5% to 10%) of ambient illumination to reach the sensor. Additionally, ambient illumination may be able to reach the sensor only through a small aperture or, window in the product case. This aperture may reduce the quantity of ambient illumination at the sensor. But, more importantly, it may reduce the sensor Field-of-View - the viewing angle range over which unobscured ambient illumination reaches the sensor.

This Application Note provides valuable optical/mechanical guidelines and insights for best performance for Intersil Ambient Light Sensor products. One of the most frequently used Intersil products, the ISL29023, is chosen to demonstrate the design concepts in the following examples.

Contents

Introduction 1

Ambient Light Sensor Field-of-View 1

The General Opto-Mechanical Reference Model 2

Window Materials 3

The Circular Aperture Model 4

Hard Aperture vs Soft Aperture 5

Appendix A: Solid-Angle Geometry 6

Appendix B: Radiometry and Photometry 8

Bibliography 9

Ambient Light Sensor Field-of-View

The Ambient Light Sensor Field-of-View (FOV) - typically expressed as $\pm\theta$ in degrees - is a critical parameter in the performance of the sensor device. A large FOV allows the sensor to integrate the illuminance over a large area, possibly including several ambient light sources or luminaires. This eliminates sensor directionality that could cause undesirable changes in display brightness due to sensor shadowing by the consumer. For example, consider a sensor with a $\pm 12.5^\circ$ FOV located in the upper frame of a desktop flat-panel monitor. At a distance of $\sim \frac{1}{2}$ meter from the monitor (typical viewing distance), the FOV span (width in space) will be $\sim 20\text{cm}$ - the width of a typical human head. If the primary luminaire is directly behind the consumer when s/he sits in front of the monitor, the consumer's head may completely shadow the sensor - thus, causing a change in the display brightness. This is not a desirable situation. However, if the sensor FOV is more like $\pm 35^\circ$, the consumer's head will subtend a solid-angle of $\sim 0.15\text{sr}$, obscuring only 13% of the sensor FOV.

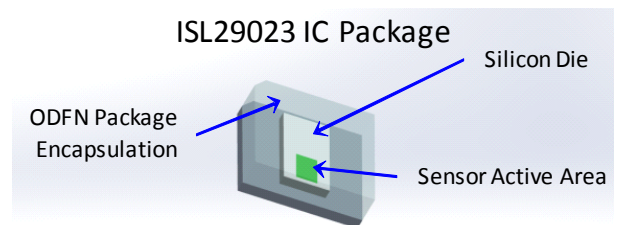

FIGURE 1. THE ISL 29023 IC PACKAGE

The sensor intrinsic FOV is defined by the angular sensitivity of the silicon photo-sensor, the geometry of the photo-sensor and the thickness and refractive index of the ODFN (Optical Dual Flat No-lead) package encapsulation. Since the ISL29023 photo-sensor is rectangular, as shown by Figure 1, the intrinsic FOV in air will have a rectangular cross-section, or pyramidal, rather than conical, shape. Thus, best illumination over the ambient FOV will be obtained using a rectangular window as shown in Figure 2. While the ISL29023 intrinsic FOV typically is $\pm 55^\circ$, the window shown in Figure 2 provides for an Ambient FOV of $\pm 35^\circ$, as recommended in previous.

The General Opto-Mechanical Reference Model

The ISL29023 Opto-Mechanical Reference Model is shown in Figure 2, illustrating the FOV, and in Figure 3, showing the principle components and dimensions. The Model consists of the ISL29023 IC package mounted to a PC board (typically, a Flex-PCB) spaced 3.0mm below a 0.7mm - thick glass Window mounted in a non-transmitting Cover Frame, or Case. The specified dimensions are typical when the ISL29023 is used in mobile consumer products with back-lit flat displays. Typically, the Frame also includes structural members that set the PCB spacing and also provide some optical isolation for the Ambient Light Sensor, ISL29023.

The glass Window is rectangular to provide best FOV for illumination of the ISL29023 photo-sensor. As shown in Figure 1, the ISL29023 photo-sensor active area is not centered in the IC package, rather offset toward one end. The Window should be centered over the Sensor active area, rather than the IC package for best performance. This provides symmetric FOV in all directions.

The Window size is defined by the desired FOV to $\pm 35^\circ$ in Figure 2 and the PCB-to-Window separation 3mm in Figure 3. Figure 4 shows the Reference Model in side view. Determination of the optimal window dimensions is a matter of simple geometry. The following steps illustrate a typical approach:

1. Select the PCB-to-Window separation distance - 3.0mm as shown in Figure 4.
2. Select the desired Field-of-View for the Ambient Light Sensor to $\pm 35^\circ$ in the Figure 4 example.
3. Determine the full Aperture-to-Sensor distance:

$$T = \text{Gap} + t_w - s_v \quad (\text{EQ. 1})$$

where Gap is the PCB-to-Window Distance, 3.0mm, t_w is Window thickness, 0.7mm, and s_v is the vertical sensor location relative to the ISL29023 IC package, 0.4mm.

4. Calculate the Window dimension:

$$\text{Win} = 2 \cdot T \cdot \tan 35^\circ + s_w \quad (\text{EQ. 2})$$

where T is the full Aperture-to-Sensor distance, and s_w is the ISL29023 sensor width, 0.49mm.

5. Adjust for the Window Material Refractive Index:

$$\Delta \text{Win} = 2 \cdot t_w \cdot \left(\tan 35^\circ - \tan \left(\frac{1}{n} \cdot 35^\circ \right) \right) \quad (\text{EQ. 3})$$

where ΔWin is the Window Width adjustment for material refractive index, and n is the material refractive index, 1.50 for common glass.

The previous steps show that the Window width is 5.11mm - $\Delta \text{Win} = 4.75\text{mm}$ (see Figures 3 and 4).

The unit-to-unit FOV tolerance is dependent on a) the window dimension tolerance, b) the PCB-to-Window tolerance, and c) the Window thickness tolerance. If the tolerance for each of the dependencies is $\pm 0.1\text{mm}$ (typical for plastic injection-molded parts), then the FOV will be $35 \pm 1.3^\circ$.

The symmetry of the FOV (positive half-angle equal to negative half-angle) depends on a) the IC placement accuracy, and b) the PCB alignment tolerance. If the tolerance for each of these also is $\pm 0.1\text{mm}$, then $\Delta \text{FOV} = \text{PHA} \pm \text{NHA}$ (Positive/Negative Half Angle) will be $\pm 3.1^\circ$.

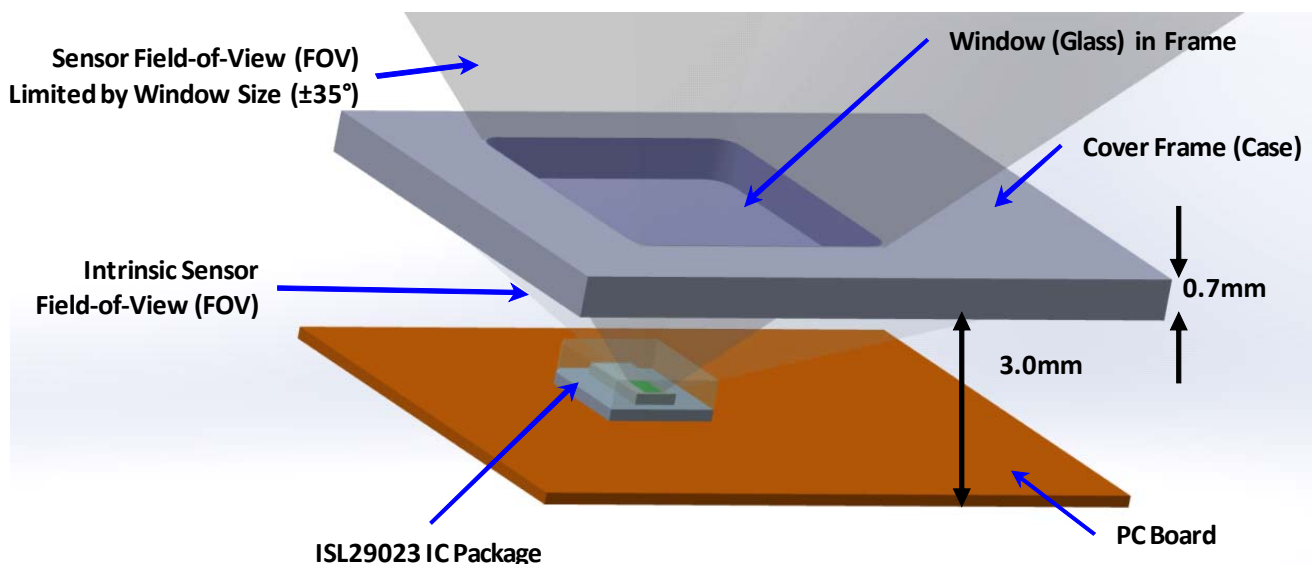

FIGURE 2. ISL29023 OPTO-MECHANICAL REFERENCE MODEL

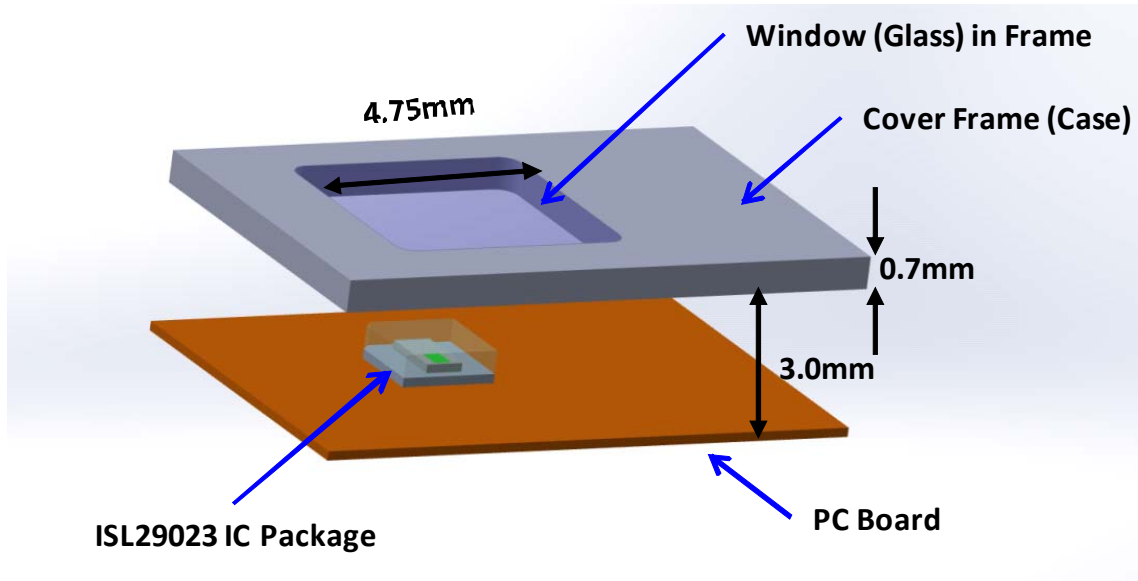

FIGURE 3. REFERENCE MODEL COMPONENTS

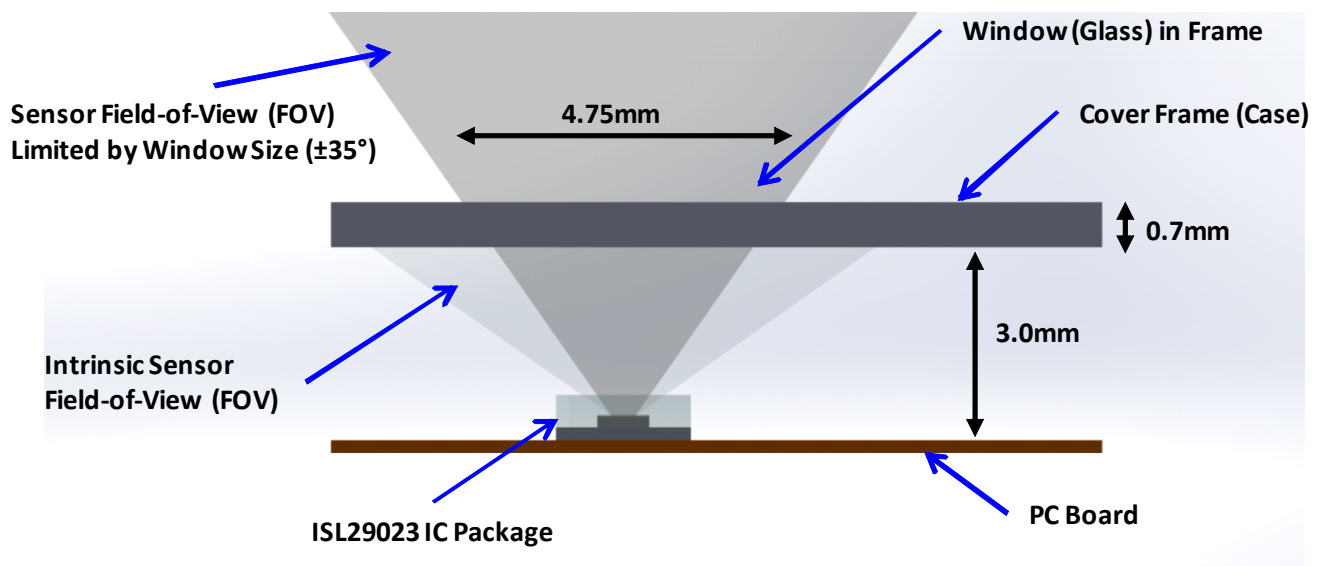

FIGURE 4. REFERENCE MODEL SIDE VIEW

Window Materials

The preceding example highlights an important point: the Window size (or FOV) is dependent on the Refractive Index of the Window and, thus, the Window material. For the example, common glass was used with a refractive index, n , of 1.50. However, not all glass is common and many other materials also may be used - such as many optical plastics. The refractive index varies with material. For typical window glasses, the refractive index varies between 1.43 and 1.55. For optical plastics, the refractive index varies from 1.48 to 1.70. The thicker the Window, the greater the effect of the material refractive index on the Window size. Table 1 provides the nominal refractive index for many window materials commonly used in mobile devices.

The Abbe Value provided in Table 1 is a measure of the optical dispersion for the material and represents the variation of the material refractive index with wavelength. A higher Abbe Value indicates a smaller index variation with wavelength, $dn/d\lambda$. Dispersion is an important factor for any visible light imaging system. Thus, lenses (or, light pipes) are used since the focal-point (or, Internal Reflection angle) for blue light may be quite different than for red light.

TABLE 1. MATERIAL REFRACTIVE INDEX

MATERIAL	INDEX	ABBE VALUE
Soda-Lime Glass	1.52	87.7
Calcium-Fluoride	1.43	94.9
Corning Gorilla Glass	1.50	n/a
Acrylic (PMMA)	1.49	57.2

TABLE 1. MATERIAL REFRACTIVE INDEX (Continued)

MATERIAL	INDEX	ABBE VALUE
Polycarbonate (PC)	1.585	34.0
Polystyrene (PS)	1.59	30.8
Olefin (COC, COP)	1.53	57.0
Polyethyleneimine (PEI)	1.68	19.0

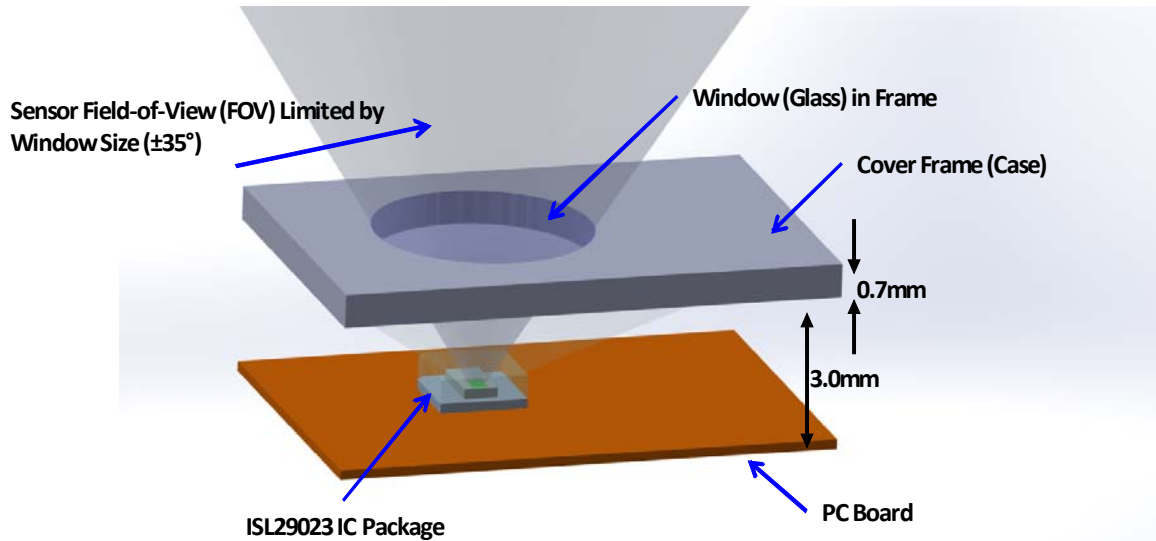

FIGURE 5. THE CIRCULAR APERTURE MODEL

The Circular Aperture Model

Circular, rather than rectangular, apertures often are preferred for windows in mobile devices. Note, much care must be taken when implementing a circular window or aperture (see Figure 5). All silicon photodetectors are fabricated in a square or, rectangular shape. Thus, the rectangular aperture provides much better illumination of the Ambient Light Sensor. A circular aperture may be used, however, it is important that the geometrical circle be circumscribed on the ideal rectangular aperture dimensions. In other words, the diameter of the circular aperture should be no less than the diagonal dimension of the ideal rectangular aperture. This condition is illustrated in Figure 6. The circumscribed circular aperture assures that the full FOV is maintained for all azimuthal angles. Optically, the rectangle aperture is more efficient: it provides greater light collecting ability (larger solid-angle, see Appendix A) with a smaller aperture.

Most Ambient Light Sensor photodetectors are segmented so that several spectral filters may be used to detect different wavelength ranges of visible and infrared ambient illumination.

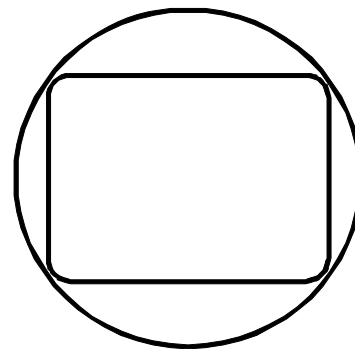

FIGURE 6. CIRCUMSCRIBED CIRCULAR APERTURE

Typically, spectral filtering is used to compensate different types of light sources, such as incandescent (blackbody) and fluorescent (non-blackbody) light sources. Figure 7 shows the spectral filter configuration for the ISL29023. Most visible spectral filters allow some level of infrared (IR) light to reach the photodetector - IR leakage. An IR spectral filter is used to separately detect the IR illumination and correct the IR leakage in the visible filter. Non-blackbody light sources, such as fluorescent lamps and LED sources typically do not emit much IR light. However, blackbody sources such as incandescent and halogen lamps emit much IR light.

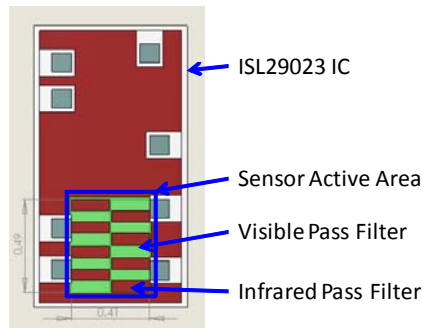

FIGURE 7. ISL29023 SPECTRAL FILTER CONFIGURATION

Sensor Field-of-View (FOV) Limited by Window Size ($\pm 35^\circ$)

Shadowing (Sensor area not illuminated) due to Circular Aperture

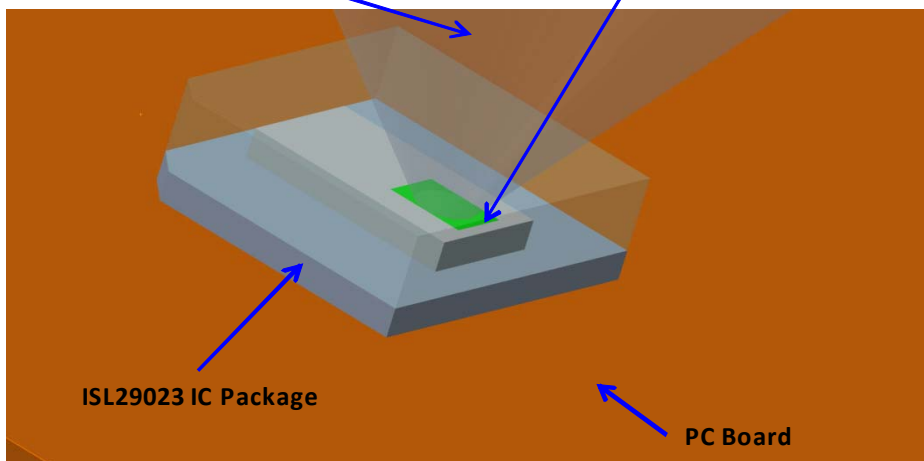

FIGURE 8. LIGHT SENSOR SHADOWING

The performance of the light source compensation (IR leakage correction) depends on uniform illumination of all the spectrally filtered detector segments. If, for example, ambient illumination is prevented (blocked) from reaching the IR-filtered photodetector, then the IR leakage circuits will not be able to properly correct the leakage condition. Figure 8 shows this "shadowing" effect on the photodetector of the ISL29023. The Ambient Light Sensor IC package on a PCB is illuminated through a circular aperture smaller than the recommended rectangular aperture described previously. The ambient illumination underfills the photodetector area. If the ambient light source is small and directional, the shadowing effect may be more pronounced; thus, further reducing the effectiveness of the IR leakage correction. Reducing the diameter of the circular aperture reduces the effective FOV and increases the probability of sensor shadowing.

Hard Aperture vs Soft Aperture

Up to this point, the reference model only has considered an insert Window in a physical aperture (opening) within the case or, frame, of the mobile product. However, another configuration frequently is implemented in mobile products. In this case, a large-area cover glass plate is used and the aperture is formed by

an opening in a printed ink layer on the inside surface of the glass plate. The ink layer is opaque to visible and IR light - thus blocking all illumination from certain directions. Typically, the aperture area also is covered by a printed ink. However, this ink allows some of the visible - and infrared - illumination to pass on to the Ambient Light Sensor. Typically, 5% to 10% of the incident visible illumination is transmitted by the aperture ink layer.

Aperture size determination is different for the case of a printed ink aperture than for the "hard," physical aperture described above. In this case, the aperture is limited to the inside surface of the glass plate and, effectively, has zero thickness. Figure 9 shows a detailed, scale drawing for the "hard" aperture configuration and Figure 10 shows the scale drawing for the "soft" aperture case.

All mechanical dimensions from the previous discussion on aperture size determination are retained in these figures. All mechanical dimensions in these two figures are the same: the PCB to Window distance, the Window (glass plate) thickness, the Window (glass plate) refractive index, and the desired FOV half-angle. The only difference is that Figure 9 shows a Window inset in the mobile device case (frame), forming a physical hard-aperture and Figure 10 shows a large glass plate with the aperture formed by the printed ink layer on the inside surface of

the glass plate. Refraction of the incident ambient light still occurs at the glass plate surfaces, just as with the hard aperture Window.

The desired FOV is the same in both cases. However, in the hard aperture case, the limiting aperture for the FOV is at the top (outside) surface of the Window (case, frame). While for the soft aperture case, the limiting aperture for the FOV is at the bottom (inside) surface of the glass plate. Locating the limiting aperture on inside surface of the glass plate reduces the required aperture dimensions shown by Equation 4.

$$2 \cdot t_w \cdot \tan(\text{FOV} \cdot \text{Half} \cdot \text{Angle}) \tag{EQ. 4}$$

where t_w is the thickness of the glass plate (window) - from 4.75mm to 4.18mm, as shown in Figures 9 and 10.

With the printed ink aperture, the determination of the aperture dimensions is somewhat simplified compared to the earlier analysis for the “Hard Aperture” case discussed on page 5.

1. Select the PCB-to-Window separation distance (3.0mm) as shown in Figure 10.
2. Select the desired Field-of-View for the Ambient Light Sensor to $\pm 35^\circ$ in this example.
3. The Aperture-to-Sensor distance is simply:

$$T = \text{Gap} - s_v \tag{EQ. 5}$$

where Gap is the PCB-to-Window Distance, 3.0mm, and s_v is the vertical sensor location relative to the ISL29023 IC package, 0.4mm.

4. Calculate the Window dimension as shown by Equation 6 :

$$W_{in} = 2 \cdot T \cdot \tan 35^\circ + s_w \tag{EQ. 6}$$

T is the Aperture-to-Sensor distance, and s_w is the ISL29023 sensor width, 0.44mm.

The adjustment for the Window (glass plate) material Refractive Index is not required for this case.

The previous steps show the Window width is 4.13mm as in Figure 10.

Since the tolerance dependencies for the FOV are reduced for the soft aperture case - the Window (glass plate) thickness is eliminated - the unit-to-unit FOV tolerance also is reduced. Assuming the tolerance for each of the dependencies remains $\pm 0.1\text{mm}$, then the FOV will be $35 \pm 1.23^\circ$. The positional tolerances effect on FOV asymmetry will remain unchanged from the hard aperture case.

Appendix A: Solid-Angle Geometry

Throughout this Application Note, FOV has been discussed in terms plane angles, particularly the FOV planar half-angle. However, in 3-dimensional space, FOV also is a 3-dimensional entity or, solid-angle, in units of steradians, sr, rather than degrees or radians. A conical solid-angle is expressed by Equation 7.

$$\Omega = \frac{a}{r^2} \tag{EQ. 7}$$

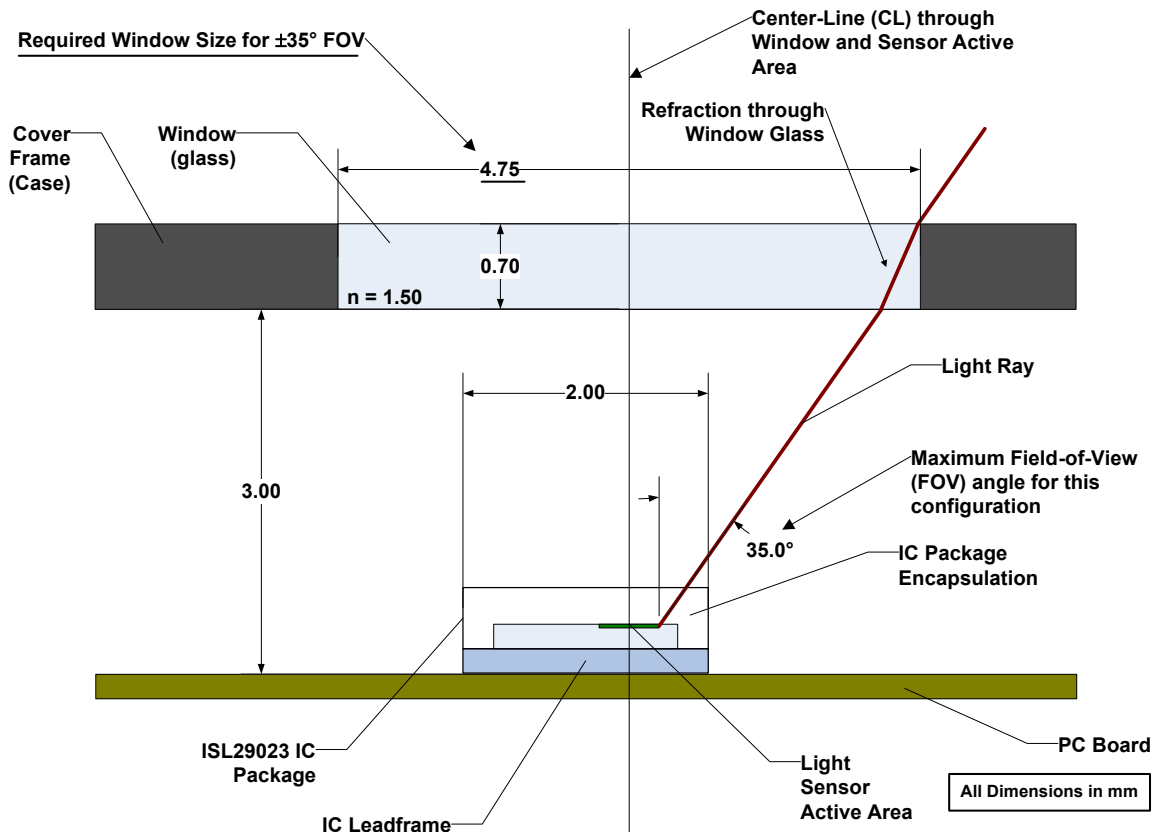

FIGURE 9. HARD APERTURE DETAILED DRAWING

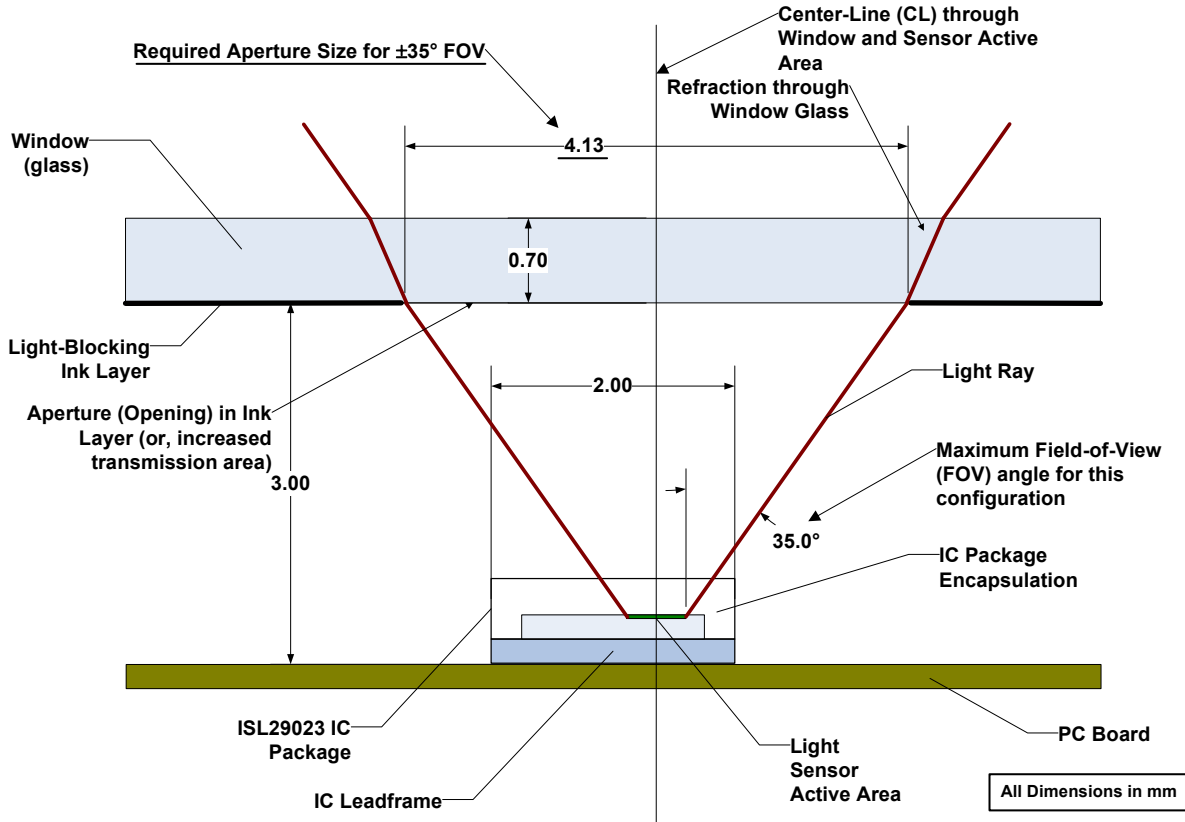

FIGURE 10. SOFT APERTURE DETAILED DRAWING

where Ω is the solid-angle, a is the area subtended by the solid-angle on a spherical surface, and r is the radial distance from the vertex of the solid-angle to spherical surface, as shown in Figure 11. The frequent reference to the "half-angle" of the FOV has not been arbitrary. The conical solid-angle, Ω , can be calculated directly from the planar half-angle:

$$\Omega = 4\pi \sin^2 \frac{1}{2} \theta_{1/2} \quad (\text{EQ. 8})$$

where Ω is the solid-angle, and $\theta_{1/2}$ is the planer half-angle in radians. So, in the previous examples, the 35° half-angle represents a solid-angle of 1.14 sr. (see Figure 10).

Surface of Sphere

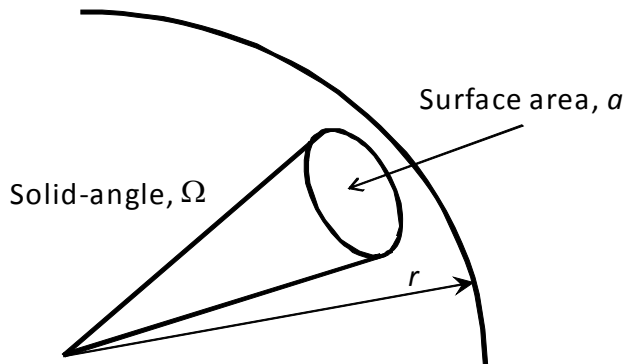

FIGURE 11. SOLID-ANGLE

In the earlier discussion, a rectangular detector area generally provides a rectangular FOV, such as with the ISL29023. The general form for the rectangular Solid-Angle is shown in Figure 12. In this case, surface area, a , is a rectangular section of the surface of the sphere with radius, r . The apex angles, a and b , subtend the vertical and horizontal sides of surface area, a . If surface area, a , is square, then apex angles $a = b$. Apex angle, $a = 2 \times \theta_{1/2}$, and apex angle, $b = 2 \times \phi_{1/2}$. The solid-angle is expressed by Equation 9.

$$\Omega = 4 \cdot \text{asin} \left(\sin \frac{a}{2} \sin \frac{b}{2} \right) \quad (\text{EQ. 9})$$

or by Equation 10.

$$\Omega = 4 \cdot \text{asin} (\sin \theta_{1/2} \sin \phi_{1/2}) \quad (\text{EQ. 10})$$

Thus, in the previous examples, the 35° half-angle rectangular solid-angle is $\Omega = 1.34$ sr.

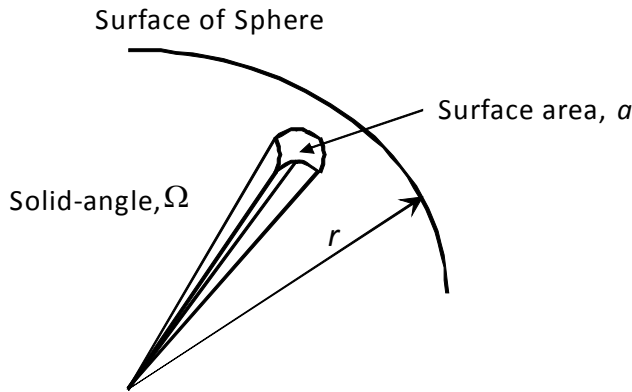

FIGURE 12. RECTANGULAR SOLID-ANGLE

Appendix B: Radiometry and Photometry

Any application of ambient light sensors (and, frequently, proximity sensors) involves radiometry and photometry and their respective units of measure. Unfortunately, in these applications, radiometry and photometry often are intermingled, which is confusing to someone not familiar with the terminology.

While this appendix, by no means, intends to fully resolve the complexity of these fields, it should provide the most basic concepts and a very brief description of the respective units of measure and their duality.

TABLE 2. RADIOMETRIC UNITS

QUANTITY	SYMBOL	DEFINITION	UNIT
Radiant Energy	Q	$\int \Phi dt$	J
Radiant Energy Density	U	dQ/dV	J/m^3
Radiant Flux (power)	Φ, P	dQ/dt	W
Radiant Exitance	M	$d\Phi/dA$	W/m^2
Irradiance	E	$d\Phi/dA$	W/m^2
Radiance	L	$d^2\Phi/dA_{proj}d\Omega$	W/m^2sr
Radiant Intensity	I	$d\Phi/d\Omega$	W/sr

Radiometry deals with the measurement of general optical radiation fields over a wide range of wavelengths, from the extreme ultraviolet (EUV) to the far infrared (FIR), including the radiative transference of heat energy. The basic SI units of optical radiant energy and radiant flux (power) are the joule and the watt. Table 2 lists the basic units of Radiometry and their relationships.

In the table, A is the area of either a radiant source or receiver (detector), Ω is the solid-angle (see Appendix A), and A_{proj} is the projected area per unit solid-angle leaving a radiant source or, any reference surface, defined by $dA_{proj} = dA \cos \theta$, where θ is the projection angle.

The first three quantities in Table 2 are self-explanatory. The remaining four quantities require a brief explanation. Radiant Exitance, Radiance, and Radiant Intensity describe optical radiation leaving a radiant source or, some arbitrary surface.

Irradiance describes optical radiation encountering a surface or, receiver such as a sensor. Typically, light sources are described by Total Radiant Flux (in all directions), Radiance (in a particular direction), or Radiant Intensity (relative to a reference solid-angle). Light receivers are described by Irradiance relative to the area of the receiver.

Photometry, on the other hand, deals with the measurement of the transference of Visible light through optical systems. Unlike radiometry, photometry only is concerned with that portion of the radiation field that can induce a visual response. The basic SI unit of Luminous Intensity is the candela (cd). Table 3 lists the basic units of Photometry and their relationships.

TABLE 3. PHOTOMETRIC UNITS

QUANTITY	SYMBOL	DEFINITION	UNIT
Luminous Energy	Q_v	$\int \Phi_v dt$	lm-s = talbot
Luminous Density	U_v	dQ_v/dV	$lm-s/m^3$
Luminous Flux	Φ_v	dQ_v/dt	lm
Illuminance	E_v	$d\Phi_v/dA$	$lm/m^2 = lx$
Luminous Exitance	M_v	$d\Phi_v/dA$	$lm/m^2 = lx$
Luminance	L_v	$d^2\Phi_v/dA_{proj}d\Omega$	$lm/m^2sr = nt$
Luminous Intensity	I_v	$d\Phi_v/d\Omega$	$lm/sr = cd$

Tables 2 and 3 show that every photometric quantity is the dual of a radiometric quantity and is defined by the same geometric relationship. From the SI base unit, candela, the unit of Luminous Flux, the lumen (lm) is derived. From the lumen, the remaining units are derived: the talbot (T), lux (lx), and nit (nt). As with radiometric quantities, Luminous Exitance, Intensity, and Luminance describe visible light energy leaving a luminous source or, a reference surface, and Illuminance describes the visible light energy incident on a receiver or, surface.

Photometric units are related to radiometric units through the standard Photopic Response, or Luminosity Function, based on the visual response of the human eye shown by Equation 11.

$$F = 683 \frac{lm}{W} \int_0^{\infty} \bar{y}(\lambda) J(\lambda) d\lambda \quad (EQ. 11)$$

Where F is the luminous flux in lumens, $J(\lambda)$ is the spectral power distribution (power per unit wavelength, in W/m), $\bar{y}(\lambda)$ is standard luminosity function (dimensionless), and λ is wavelength in meters. Typically, the standard luminosity function is normalized to 683 lm/W at 555nm.

Bibliography

Datasheets

ISL29023: Integrated Digital Light Sensor with Interrupt, 2012,
Intersil, Corp.,

<http://www.intersil.com/content/dam/Intersil/documents/fn66/fn6691.pdf>

Technical References

Radiometry and the Detection of Optical Radiation, Robert W.
Boyd, 1983, John Wiley & Sons, Inc.

The Art of Radiometry, James M. Palmer and Barbara G. Grant,
2010, Society of Photo-Optical Instrumentation Engineers (SPIE).

"Photometry (Optics),"

[http://en.wikipedia.org/wiki/Photometry_\(optics\)](http://en.wikipedia.org/wiki/Photometry_(optics)).

Author

Allen M. Earman

Principal Optical Applications Engineer

Intersil Corp.

1001 Murphy Ranch Road

Milpitas, California, USA, 95035

Notice

1. Descriptions of circuits, software and other related information in this document are provided only to illustrate the operation of semiconductor products and application examples. You are fully responsible for the incorporation or any other use of the circuits, software, and information in the design of your product or system. Renesas Electronics disclaims any and all liability for any losses and damages incurred by you or third parties arising from the use of these circuits, software, or information.
2. Renesas Electronics hereby expressly disclaims any warranties against and liability for infringement or any other claims involving patents, copyrights, or other intellectual property rights of third parties, by or arising from the use of Renesas Electronics products or technical information described in this document, including but not limited to, the product data, drawings, charts, programs, algorithms, and application examples.
3. No license, express, implied or otherwise, is granted hereby under any patents, copyrights or other intellectual property rights of Renesas Electronics or others.
4. You shall not alter, modify, copy, or reverse engineer any Renesas Electronics product, whether in whole or in part. Renesas Electronics disclaims any and all liability for any losses or damages incurred by you or third parties arising from such alteration, modification, copying or reverse engineering.
5. Renesas Electronics products are classified according to the following two quality grades: "Standard" and "High Quality". The intended applications for each Renesas Electronics product depends on the product's quality grade, as indicated below.
"Standard": Computers; office equipment; communications equipment; test and measurement equipment; audio and visual equipment; home electronic appliances; machine tools; personal electronic equipment; industrial robots; etc.
"High Quality": Transportation equipment (automobiles, trains, ships, etc.); traffic control (traffic lights); large-scale communication equipment; key financial terminal systems; safety control equipment; etc.
Unless expressly designated as a high reliability product or a product for harsh environments in a Renesas Electronics data sheet or other Renesas Electronics document, Renesas Electronics products are not intended or authorized for use in products or systems that may pose a direct threat to human life or bodily injury (artificial life support devices or systems; surgical implantations; etc.), or may cause serious property damage (space system; undersea repeaters; nuclear power control systems; aircraft control systems; key plant systems; military equipment; etc.). Renesas Electronics disclaims any and all liability for any damages or losses incurred by you or any third parties arising from the use of any Renesas Electronics product that is inconsistent with any Renesas Electronics data sheet, user's manual or other Renesas Electronics document.
6. When using Renesas Electronics products, refer to the latest product information (data sheets, user's manuals, application notes, "General Notes for Handling and Using Semiconductor Devices" in the reliability handbook, etc.), and ensure that usage conditions are within the ranges specified by Renesas Electronics with respect to maximum ratings, operating power supply voltage range, heat dissipation characteristics, installation, etc. Renesas Electronics disclaims any and all liability for any malfunctions, failure or accident arising out of the use of Renesas Electronics products outside of such specified ranges.
7. Although Renesas Electronics endeavors to improve the quality and reliability of Renesas Electronics products, semiconductor products have specific characteristics, such as the occurrence of failure at a certain rate and malfunctions under certain use conditions. Unless designated as a high reliability product or a product for harsh environments in a Renesas Electronics data sheet or other Renesas Electronics document, Renesas Electronics products are not subject to radiation resistance design. You are responsible for implementing safety measures to guard against the possibility of bodily injury, injury or damage caused by fire, and/or danger to the public in the event of a failure or malfunction of Renesas Electronics products, such as safety design for hardware and software, including but not limited to redundancy, fire control and malfunction prevention, appropriate treatment for aging degradation or any other appropriate measures. Because the evaluation of microcomputer software alone is very difficult and impractical, you are responsible for evaluating the safety of the final products or systems manufactured by you.
8. Please contact a Renesas Electronics sales office for details as to environmental matters such as the environmental compatibility of each Renesas Electronics product. You are responsible for carefully and sufficiently investigating applicable laws and regulations that regulate the inclusion or use of controlled substances, including without limitation, the EU RoHS Directive, and using Renesas Electronics products in compliance with all these applicable laws and regulations. Renesas Electronics disclaims any and all liability for damages or losses occurring as a result of your noncompliance with applicable laws and regulations.
9. Renesas Electronics products and technologies shall not be used for or incorporated into any products or systems whose manufacture, use, or sale is prohibited under any applicable domestic or foreign laws or regulations. You shall comply with any applicable export control laws and regulations promulgated and administered by the governments of any countries asserting jurisdiction over the parties or transactions.
10. It is the responsibility of the buyer or distributor of Renesas Electronics products, or any other party who distributes, disposes of, or otherwise sells or transfers the product to a third party, to notify such third party in advance of the contents and conditions set forth in this document.
11. This document shall not be reprinted, reproduced or duplicated in any form, in whole or in part, without prior written consent of Renesas Electronics.
12. Please contact a Renesas Electronics sales office if you have any questions regarding the information contained in this document or Renesas Electronics products.
(Note 1) "Renesas Electronics" as used in this document means Renesas Electronics Corporation and also includes its directly or indirectly controlled subsidiaries.
(Note 2) "Renesas Electronics product(s)" means any product developed or manufactured by or for Renesas Electronics.

(Rev.4.0-1 November 2017)



SALES OFFICES

Renesas Electronics Corporation

<http://www.renesas.com>

Refer to "<http://www.renesas.com/>" for the latest and detailed information.

Renesas Electronics America Inc.
1001 Murphy Ranch Road, Milpitas, CA 95035, U.S.A.
Tel: +1-408-432-8888, Fax: +1-408-434-5351

Renesas Electronics Canada Limited
9251 Yonge Street, Suite 8309 Richmond Hill, Ontario Canada L4C 9T3
Tel: +1-905-237-2004

Renesas Electronics Europe Limited
Dukes Meadow, Millboard Road, Bourne End, Buckinghamshire, SL8 5FH, U.K
Tel: +44-1628-651-700, Fax: +44-1628-651-804

Renesas Electronics Europe GmbH
Arcadiastrasse 10, 40472 Düsseldorf, Germany
Tel: +49-211-6503-0, Fax: +49-211-6503-1327

Renesas Electronics (China) Co., Ltd.
Room 1709 Quantum Plaza, No.27 ZhichunLu, Haidian District, Beijing, 100191 P. R. China
Tel: +86-10-8235-1155, Fax: +86-10-8235-7679

Renesas Electronics (Shanghai) Co., Ltd.
Unit 301, Tower A, Central Towers, 555 Langao Road, Putuo District, Shanghai, 200333 P. R. China
Tel: +86-21-2226-0888, Fax: +86-21-2226-0999

Renesas Electronics Hong Kong Limited
Unit 1601-1611, 16/F., Tower 2, Grand Century Place, 193 Prince Edward Road West, Mongkok, Kowloon, Hong Kong
Tel: +852-2265-6688, Fax: +852-2886-9022

Renesas Electronics Taiwan Co., Ltd.
13F, No. 363, Fu Shing North Road, Taipei 10543, Taiwan
Tel: +886-2-8175-9600, Fax: +886-2-8175-9670

Renesas Electronics Singapore Pte. Ltd.
80 Bendemeer Road, Unit #06-02 Hyflux Innovation Centre, Singapore 339949
Tel: +65-6213-0200, Fax: +65-6213-0300

Renesas Electronics Malaysia Sdn.Bhd.
Unit 1207, Block B, Menara Amcorp, Amcorp Trade Centre, No. 18, Jln Persiaran Barat, 46050 Petaling Jaya, Selangor Darul Ehsan, Malaysia
Tel: +60-3-7955-9390, Fax: +60-3-7955-9510

Renesas Electronics India Pvt. Ltd.
No.777C, 100 Feet Road, HAL 2nd Stage, Indiranagar, Bangalore 560 038, India
Tel: +91-80-67208700, Fax: +91-80-67208777

Renesas Electronics Korea Co., Ltd.
17F, KAMCO Yangjae Tower, 262, Gangnam-daero, Gangnam-gu, Seoul, 06265 Korea
Tel: +82-2-558-3737, Fax: +82-2-558-5338