

Development of a Spice Op-Amp Macro Model for Current-Feedback Amplifiers
DC/DC Module Trim with Digital Potentiometers

Current-feedback amplifiers (CFAs) are the high-speed relatives of more common voltage-feedback amplifiers (VFAs). CFAs have wider bandwidths and faster slew rates. Applications such as DSL rely on their fast and strong output drives.

Models are important because they allow engineers to test designs before they go through the time-intensive and costly process of building a working prototype. In this application note, we introduce you to a circuit model for a current-feedback amplifier. Since it would take far too long to simulate every nuance of a complete design, this macro model simulates the most common effects, such as transient response, frequency response, voltage noise and output slew rate limiting. Detailed descriptions of each stage in the model will be presented with examples of model performance and correlation to actual device behavior.

Figure 1 shows the conceptual approach of the current feedback amplifier. CFAs have a unity gain buffer to force the inverting input (V_{in-}) to follow the non-inverting input (V_{in+}). This topology is very different from the high impedance inputs of the voltage-feedback amplifier. In the CFA case, the inverting input node shows the low input impedance (Z_{in-}) from the output of the buffer. The error signal is the current (I) flowing into or out of the inverting node. The error current is converted by a large transimpedance, Z , to the output voltage. R_f is used to control the feedback current. This is another major deviation from the voltage-feedback topology. In VFAs, the feedback network (R_f and R_g) primarily set the voltage gain. In CFAs, the feedback network does set the gain, but the value of R_f also controls the bandwidth of the amplifier.

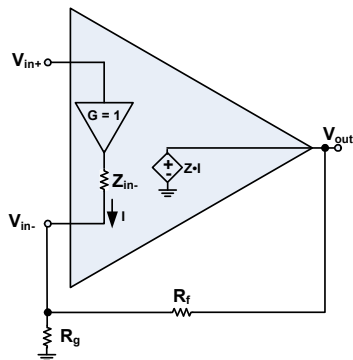

FIGURE 1. THE BLOCK DIAGRAM OF A CURRENT FEEDBACK AMPLIFIER

A five-stage model represents the actual circuit and the block diagram is shown in Figure 2. These five basic blocks are the input stage, the gain stage, the frequency-shaping stage, the output stage and the noise module.

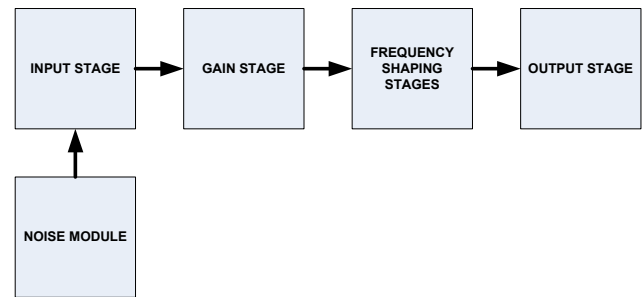

FIGURE 2. THE BLOCK DIAGRAM OF A CFA MACRO MODEL

The Input Stage

As stated, the biggest difference between a CFA and a VFA is the input stage. Figure 3 shows an example, the input stage of a CFA model. Four bipolar transistors are included, Q1 to Q4. The effective output of this stage is at nodes 11 and 12, which are coupled into the gain stage by using voltage controlled current source. The bias current I_1 - I_2 of Q1-Q2 should be set by:

$$I_1 = I_2 = \frac{kT}{2q \cdot Z_{in-}} \quad \text{i.e.} \quad Z_{in-} = \frac{1}{2g_m} \quad (\text{EQ. 1})$$

The impedance at the inverting input, Z_{in-} , can be measured. In this example, $I_1 = I_2 = 85\mu\text{A}$. R_1 , R_2 , C_1 , C_2 are used to fit the frequency response and to control the input stage slew rate.

There are many other components used in the input block. C_{s1} and C_{s2} are the inverting input capacitance. C_{in1} is the non-inverting input capacitance. The input bias current is modeled by current sources I_{b1} and I_{b2} . The input offset voltage is modeled by the voltage source V_{os} . The current source G_{b1} is used to model the input current common mode rejection at the inverting input.

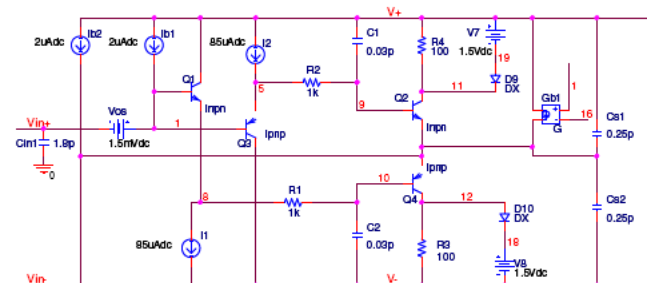

FIGURE 3. INPUT STAGE OF A CFA (EL5165)

The Gain Stage

This stage is similar to the gain stage of a VFA. It performs many important functions.

1. This stage sets the open loop trans-impedance of the part.
2. It provides output slew rate limiting.
3. It contributes the dominant pole to the AC characteristic.
4. It level shifts the signal from two voltages referred to the supplies to a single voltage referred to the mid-point.
5. It limits the output voltage swing.

Taking a closer look at the components of the gain stage in Figure 4, slew rate limiting is set by limiting the current to C3 and C4 in Figure 4. The current limiting is set in the input stage by clamping the voltage across R3 and R4 shown in Figure 3. This voltage is decided by voltage sources V1 and V2 and diodes D1 and D2. R7-C3 and R8-C4 decide the dominant pole of this model. D3-D4 and V5-V6 are used to control the output clamping voltage.

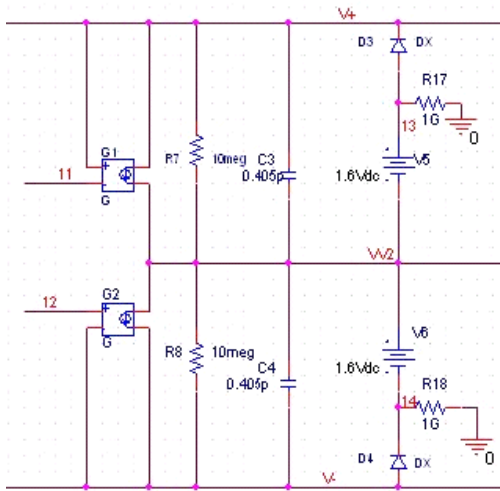

FIGURE 4. GAIN STAGE

Frequency-Shaping Stages

The frequency-shaping stages of a CFA model are very similar to that of a VFA. Each frequency-shaping block provides unity gain, so it is easy to add more poles and zeros. For more information of the frequency-shaping stages, see [Reference 2]. For our example op amp, only three pole stages are used, which is shown in Figure 5. E3 is used to set the reference level at the middle of the supplies, V+ and V-.

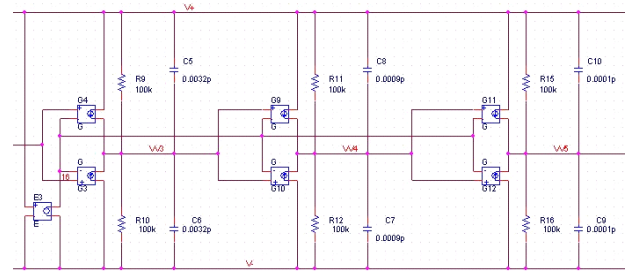

FIGURE 5. HIGHER ORDER POLE STAGES

Noise Module

The input current noise of the current feedback op amp model can't be neglected. It is described as:

$$pA / \sqrt{Hz}$$

Voltage noise is also important, so both a voltage noise module and a current noise module are needed for our CFA model.

For the right noise analysis, one trick called "noiseless resistors" can be used at the input stage. All the resistors in the input stage should be substituted by voltage controlled current sources (Device G in SPICE) where input and output terminals are connected together and the gm is set to the reciprocal of the required resistance.

We will use two pieces to construct the total noise model. The noise module of Figure 6 generates 1/f and white noise by using a 1.5V voltage source biasing a diode-resistor series combination. White noise is generated by the thermal noise-current generated in the material of the resistors.

$$i_n^2 = \frac{4kT}{R} \quad \text{where } k \text{ is the Boltzmann's constant} \quad (\text{EQ. 2})$$

So the required value of the resistor for a given noise-voltage spectral density is:

$$R = \frac{e_n^2}{2 \times 4kT} \quad \text{where } e_n \text{ is the spectral density of the white noise voltage} \quad (\text{EQ. 3})$$

Flicker noise, also called 1/f noise, refers to the noise exhibiting power spectral density inversely proportional to the frequency. More generally, this noise has a spectral density of:

$$S_N \propto \frac{1}{|f|^\beta} \quad \text{where } \beta > 0 \quad (\text{EQ. 4})$$

As a data point, the frequency where the flicker noise curve crosses the white noise curve is defined as the corner frequency. The small amount of flicker noise that remains is modeled within the SPICE diode model. Referring to Figure 6,

$$i_n^2 = 2qI_d + KF \cdot \frac{I_d^{AF}}{\text{frequency}} \quad (\text{EQ. 5})$$

where I_d is the DC diode current. AF and KF are the model parameters of the SPICE diode and q is the charge of the electron. The flicker noise exponent (AF) is set to 1 and the flicker noise coefficient (KF) is set:

$$KF = \frac{E_a^2}{2R^2 \bullet I_d} \quad \text{where } E_a \text{ is the noise-voltage spectral density at 1Hz.} \quad (\text{EQ. 6})$$

The simulated voltage noise will show the $1/f$ noise-voltage spectral density with the correct corner frequency.

The noise module in Figure 7 only simulates the white noise portion of the current noise by utilizing thermal noise of two parallel resistors.

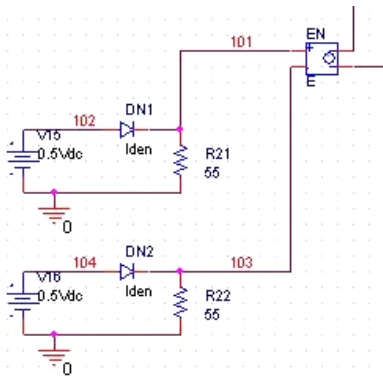

FIGURE 6. NOISE VOLTAGE MODULE

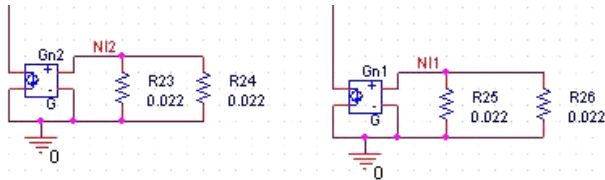

FIGURE 7. NOISE CURRENT MODULE

Output Stage

After the frequency shaping-stages, the signal appears at Node VV5, which is referenced to the midpoint of the two supply rails. Each controlled source can generate enough current to support the desired voltage drop across its parallel resistor. R13 and R14 are equal to twice the open loop output resistance, so their parallel combination gives the correct Z_{out} . D5-D8 and G9-10 are used to force a current from the positive rail to the negative rail to correct the real current sink or source. G11-12 drive the output.

$$G9 = G10 = G11 = G12 = \frac{1}{2Z_{out}} \quad (\text{EQ. 7})$$

$$R13 = R14 = 2Z_{out} \quad (\text{EQ. 8})$$

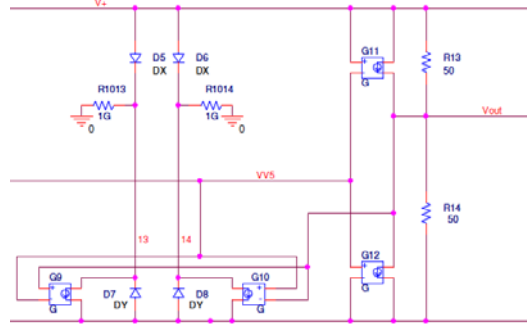

FIGURE 8. OUTPUT STAGE

Simulation Results

The simulation results of the macro model should be compared with the real world device to verify its functionality. The example op amp used in this application note is the EL5165, a high speed current feedback amplifier. Some SPICE simulation results are compared with the measured results.

The gain plots in Figure 9 shows a remarkable similarity between our model on the left at a gain of two and measurements from the EL5165 on the right. The measurements from the device are taken at both unity gain and a gain of two. There is less than 1% error between the -3dB frequency of the two gain-of-two measurements.

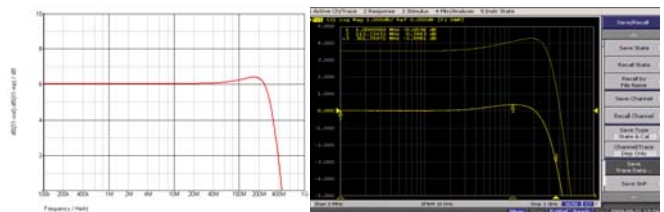

FIGURE 9. AC RESPONSE FOR GAIN = +2 OF THE MACRO MODEL (LEFT) AND EL5165 (RIGHT) ($R_f = 499\Omega$)

At a gain of three, the discrepancy increases a bit, as shown in Figure 10. Now the error in cut-off frequency is within 5%.

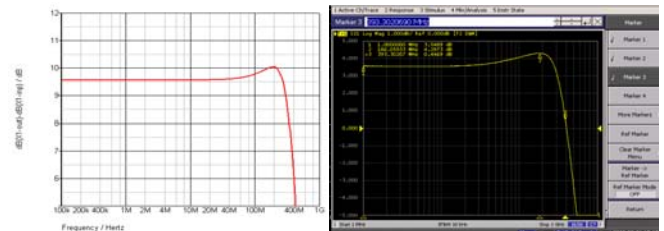

FIGURE 10. AC RESPONSE FOR GAIN = +3 OF THE MACRO MODEL (LEFT) AND EL5165 DEVICE (RIGHT) ($R_f = 249\Omega$)

Since the feedback resistor controls the bandwidth, we offer a comparison of frequency response for a range of resistors in Figure 11. The values of resistance are listed on the plot on the right that comes from the data sheet. The left plot is from our macro model. Again, the matching of -3dB frequency is within 5%.

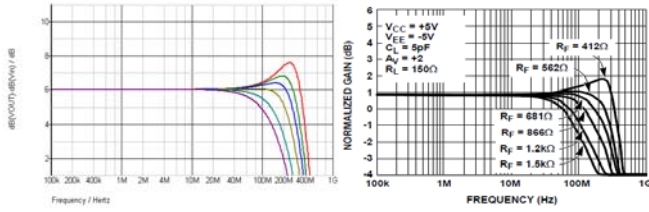

FIGURE 11. FREQUENCY RESPONSE WITH DIFFERENT RF FOR THE MODEL (LEFT) AND THE DEVICE (RIGHT)

After examining the small-signal response versus frequency, the next logical step is to inspect the large-signal response, as shown in Figure 12. Here we look at the slew rate of the step response with a gain of two driving a load of 150Ω from a ±5V supply. While the time base (x-axis) is at different resolutions in the two plots, the slew rate of the macro model shown on the left is 5000V/μs. This agrees to 5% from the slew rate on the output signal of the EL5165 on the right.

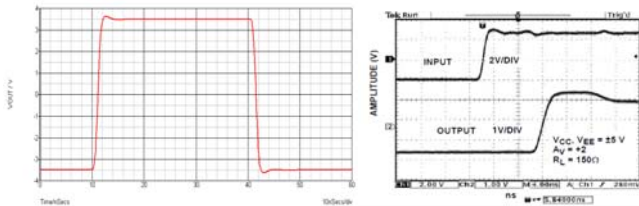

FIGURE 12. LARGE-SIGNAL STEP RESPONSE FOR THE MACRO MODEL (LEFT) AND FROM THE DEVICE DATA SHEET (RIGHT)

After frequency response and slew rate, our next goal is to match the noise performance. We have chosen to demonstrate the voltage noise, so the model in Figure 6 is included, but not the current noise model from Figure 7. The voltage noise model exhibits the spectrum shown in the plot on the left and has a value of

$$2.15 \text{ nV} / \sqrt{\text{Hz}} \text{ at } 1\text{MHz}$$

The datasheet curve for voltage noise is on the right and has a value of:

$$2.1 \text{ nV} / \sqrt{\text{Hz}} \text{ at } 1\text{MHz}.$$

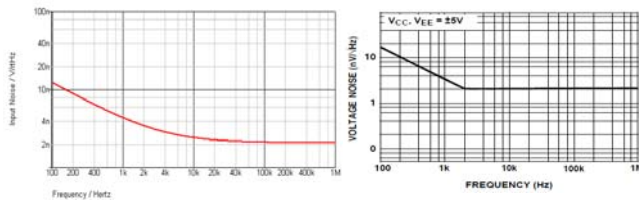

FIGURE 13. INPUT NOISE VOLTAGE VERSUS FREQUENCY FOR MACRO MODEL (LEFT) AND DEVICE DATA SHEET (RIGHT)

Conclusion

A more comprehensive SPICE macro model for a current feedback amplifier is developed. This macro model includes effects such as transfer response, accurate AC response, DC offset and voltage noise. It is convenient to use such a model and change the parameters to fit other current feedback amplifiers.

Several of Intersil's current feedback amplifiers use the same model topology with different internal model values.

EL5165 Macro Model Netlist

```
.subckt EL5165 3 2 7 4 6
```

*

*Input Stage

```
C_Cin1 0 3 1.8p
V_Vos 1 N4150175 1.5mVdc
I_I1 8 4 DC 85uAdc
I_I2 7 5 DC 85uAdc
I_Ib1 7 1 DC 2uAdc
I_Ib2 7 2 DC 2uAdc
G_Gi1 8 10 8 10 0.001
G_Gi2 5 9 5 9 0.001
G_Gi3 12 4 12 4 0.01
G_Gi4 7 11 7 11 0.01
G_Gb1 7 2 1 16 0.0000001
Q_Q1 7 1 8 Inpn
Q_Q2 11 9 2 Inpn
Q_Q3 4 1 5 Ipnp
Q_Q4 12 10 2 Ipnp
D_D9 19 11 DX
D_D10 12 18 DX
V_V7 7 19 1.5dc
V_V8 18 4 1.5Vdc
C_C1 9 7 0.03p
C_C2 4 10 0.03p
C_Cs1 2 7 0.25p
C_Cs2 4 2 0.25p
I_I3 7 4 DC 3mAdc
*Gain stage
C_C3 VV2 7 0.405p
C_C4 4 VV2 0.405p
D_D3 13 7 DX
D_D4 4 14 DX
G_G1 7 VV2 7 11 0.01
G_G2 VV2 4 12 4 0.01
R_R7 VV2 7 10meg
R_R8 4 VV2 10meg
R_R17 13 0 1G
```

```

R_R18    14 0 1G
V_V5     13 VV2 1.6Vdc
V_V6     VV2 14 1.6Vdc
*High-order poles
E_E3     16 4 7 4 0.5
C_C5     VV3 7 0.0032p
C_C6     4 VV3 0.0032p
C_C7     4 VV4 0.0009p
C_C8     VV4 7 0.0009p
C_C9     4 VV5 0.0001p
C_C10    VV5 7 0.0001p
R_R9     VV3 7 100k
R_R10    4 VV3 100k
R_R11    VV4 7 100k
R_R12    4 VV4 100k
R_R15    VV5 7 100k
R_R16    4 VV5 100k
G_G3     4 VV3 VV2 16 0.00001
G_G4     7 VV3 VV2 16 0.00001
G_G9     7 VV4 VV3 16 0.00001
G_G10    4 VV4 VV3 16 0.00001
G_G11    7 VV5 VV4 16 0.00001
G_G12    4 VV5 VV4 16 0.00001
*Output stage
G_G5     15 4 6 VV5 0.0001
G_G6     17 4 VV5 6 0.0001
G_G7     7 6 7 VV5 -0.04
G_G8     6 4 VV5 4 -0.04
R_R13    6 7 25
R_R14    4 6 25
D_D5     7 15 DX
D_D6     7 17 DX
D_D7     4 15 DY
D_D8     4 17 DY
*Voltage noise
E_EN     N4150175 3 101 103 1
V_V15    102 0 0.5Vdc
V_V16    104 0 0.5Vdc
D_DN1    102 101 Iden
D_DN2    104 103 Iden
R_R21    0 101 55
R_R22    0 103 55
*Current noise
R_R23    0 NI2 0.022
R_R24    0 NI2 0.022
R_R25    0 NI1 0.022
R_R26    0 NI1 0.022
G_Gn1    3 0 NI1 0 1
G_Gn2    2 0 NI2 0 1
*
* Models
*
.model lnpn pnp(is=1e-15 bf=1E9 VAF=65)
.model lnnp npn(is=1e-15 bf=1E9 VAF=65)
.model lden d(kf=100e-14 af=1)
.MODEL DY D(IS=1E-20 BV=50 Rs=1)
.MODEL DX D(IS=1E-15 Rs=1)
.ends EL5165

```

References

- [1] Derek Bowers, Mark Alexander, Joe Buxton, "A Comprehensive Simulation Macromodels for 'Current Feedback' Operational Amplifiers," IEEE Proceedings, Vol. 137, April 1990 pp.137-145.
- [2] Mark Alexander, Derek Bowers, "AN-138 SPICE-Compatible Op Amp Macro-Models", Analog Devices Inc., Application Note 138.
- [3] "AN-840 Development of an Extensive SPICE Macromodel for 'Current-Feedback' Amplifiers", National Semiconductor Corp., Application Note 840.
- [4] "Current Feedback Amplifier Theory and Applications", Intersil Corp., Application Note 9420.

Notice

1. Descriptions of circuits, software and other related information in this document are provided only to illustrate the operation of semiconductor products and application examples. You are fully responsible for the incorporation or any other use of the circuits, software, and information in the design of your product or system. Renesas Electronics disclaims any and all liability for any losses and damages incurred by you or third parties arising from the use of these circuits, software, or information.
 2. Renesas Electronics hereby expressly disclaims any warranties against and liability for infringement or any other claims involving patents, copyrights, or other intellectual property rights of third parties, by or arising from the use of Renesas Electronics products or technical information described in this document, including but not limited to, the product data, drawings, charts, programs, algorithms, and application examples.
 3. No license, express, implied or otherwise, is granted hereby under any patents, copyrights or other intellectual property rights of Renesas Electronics or others.
 4. You shall not alter, modify, copy, or reverse engineer any Renesas Electronics product, whether in whole or in part. Renesas Electronics disclaims any and all liability for any losses or damages incurred by you or third parties arising from such alteration, modification, copying or reverse engineering.
 5. Renesas Electronics products are classified according to the following two quality grades: "Standard" and "High Quality". The intended applications for each Renesas Electronics product depends on the product's quality grade, as indicated below.
"Standard": Computers; office equipment; communications equipment; test and measurement equipment; audio and visual equipment; home electronic appliances; machine tools; personal electronic equipment; industrial robots; etc.
"High Quality": Transportation equipment (automobiles, trains, ships, etc.); traffic control (traffic lights); large-scale communication equipment; key financial terminal systems; safety control equipment; etc.
Unless expressly designated as a high reliability product or a product for harsh environments in a Renesas Electronics data sheet or other Renesas Electronics document, Renesas Electronics products are not intended or authorized for use in products or systems that may pose a direct threat to human life or bodily injury (artificial life support devices or systems; surgical implantations; etc.), or may cause serious property damage (space system; undersea repeaters; nuclear power control systems; aircraft control systems; key plant systems; military equipment; etc.). Renesas Electronics disclaims any and all liability for any damages or losses incurred by you or any third parties arising from the use of any Renesas Electronics product that is inconsistent with any Renesas Electronics data sheet, user's manual or other Renesas Electronics document.
 6. When using Renesas Electronics products, refer to the latest product information (data sheets, user's manuals, application notes, "General Notes for Handling and Using Semiconductor Devices" in the reliability handbook, etc.), and ensure that usage conditions are within the ranges specified by Renesas Electronics with respect to maximum ratings, operating power supply voltage range, heat dissipation characteristics, installation, etc. Renesas Electronics disclaims any and all liability for any malfunctions, failure or accident arising out of the use of Renesas Electronics products outside of such specified ranges.
 7. Although Renesas Electronics endeavors to improve the quality and reliability of Renesas Electronics products, semiconductor products have specific characteristics, such as the occurrence of failure at a certain rate and malfunctions under certain use conditions. Unless designated as a high reliability product or a product for harsh environments in a Renesas Electronics data sheet or other Renesas Electronics document, Renesas Electronics products are not subject to radiation resistance design. You are responsible for implementing safety measures to guard against the possibility of bodily injury, injury or damage caused by fire, and/or danger to the public in the event of a failure or malfunction of Renesas Electronics products, such as safety design for hardware and software, including but not limited to redundancy, fire control and malfunction prevention, appropriate treatment for aging degradation or any other appropriate measures. Because the evaluation of microcomputer software alone is very difficult and impractical, you are responsible for evaluating the safety of the final products or systems manufactured by you.
 8. Please contact a Renesas Electronics sales office for details as to environmental matters such as the environmental compatibility of each Renesas Electronics product. You are responsible for carefully and sufficiently investigating applicable laws and regulations that regulate the inclusion or use of controlled substances, including without limitation, the EU RoHS Directive, and using Renesas Electronics products in compliance with all these applicable laws and regulations. Renesas Electronics disclaims any and all liability for damages or losses occurring as a result of your noncompliance with applicable laws and regulations.
 9. Renesas Electronics products and technologies shall not be used for or incorporated into any products or systems whose manufacture, use, or sale is prohibited under any applicable domestic or foreign laws or regulations. You shall comply with any applicable export control laws and regulations promulgated and administered by the governments of any countries asserting jurisdiction over the parties or transactions.
 10. It is the responsibility of the buyer or distributor of Renesas Electronics products, or any other party who distributes, disposes of, or otherwise sells or transfers the product to a third party, to notify such third party in advance of the contents and conditions set forth in this document.
 11. This document shall not be reprinted, reproduced or duplicated in any form, in whole or in part, without prior written consent of Renesas Electronics.
 12. Please contact a Renesas Electronics sales office if you have any questions regarding the information contained in this document or Renesas Electronics products.
- (Note 1) "Renesas Electronics" as used in this document means Renesas Electronics Corporation and also includes its directly or indirectly controlled subsidiaries.
(Note 2) "Renesas Electronics product(s)" means any product developed or manufactured by or for Renesas Electronics.

(Rev.4.0-1 November 2017)



SALES OFFICES

Renesas Electronics Corporation

<http://www.renesas.com>

Refer to "<http://www.renesas.com/>" for the latest and detailed information.

Renesas Electronics America Inc.
1001 Murphy Ranch Road, Milpitas, CA 95035, U.S.A.
Tel: +1-408-432-8888, Fax: +1-408-434-5351

Renesas Electronics Canada Limited
9251 Yonge Street, Suite 8309 Richmond Hill, Ontario Canada L4C 9T3
Tel: +1-905-237-2004

Renesas Electronics Europe Limited
Dukes Meadow, Millboard Road, Bourne End, Buckinghamshire, SL8 5FH, U.K
Tel: +44-1628-651-700, Fax: +44-1628-651-804

Renesas Electronics Europe GmbH
Arcadiastrasse 10, 40472 Düsseldorf, Germany
Tel: +49-211-6503-0, Fax: +49-211-6503-1327

Renesas Electronics (China) Co., Ltd.
Room 1709 Quantum Plaza, No.27 ZhichunLu, Haidian District, Beijing, 100191 P. R. China
Tel: +86-10-8235-1155, Fax: +86-10-8235-7679

Renesas Electronics (Shanghai) Co., Ltd.
Unit 301, Tower A, Central Towers, 555 Langao Road, Putuo District, Shanghai, 200333 P. R. China
Tel: +86-21-2226-0888, Fax: +86-21-2226-0999

Renesas Electronics Hong Kong Limited
Unit 1601-1611, 16/F., Tower 2, Grand Century Place, 193 Prince Edward Road West, Mongkok, Kowloon, Hong Kong
Tel: +852-2265-6688, Fax: +852-2886-9022

Renesas Electronics Taiwan Co., Ltd.
13F, No. 363, Fu Shing North Road, Taipei 10543, Taiwan
Tel: +886-2-8175-9600, Fax: +886-2-8175-9670

Renesas Electronics Singapore Pte. Ltd.
80 Bendemeer Road, Unit #06-02 Hyflux Innovation Centre, Singapore 339949
Tel: +65-6213-0200, Fax: +65-6213-0300

Renesas Electronics Malaysia Sdn.Bhd.
Unit 1207, Block B, Menara Amcorp, Amcorp Trade Centre, No. 18, Jln Persiaran Barat, 46050 Petaling Jaya, Selangor Darul Ehsan, Malaysia
Tel: +60-3-7955-9390, Fax: +60-3-7955-9510

Renesas Electronics India Pvt. Ltd.
No.777C, 100 Feet Road, HAL 2nd Stage, Indiranagar, Bangalore 560 038, India
Tel: +91-80-67208700, Fax: +91-80-67208777

Renesas Electronics Korea Co., Ltd.
17F, KAMCO Yangjae Tower, 262, Gangnam-daero, Gangnam-gu, Seoul, 06265 Korea
Tel: +82-2-558-3737, Fax: +82-2-558-5338