

Introduction

This application note is focused on exploiting the RF design capabilities of ISL73096RH/ISL73127RH/ISL73128RH transistor arrays. Detailed design procedures, using these transistor arrays, for a matched (800MHz to 2500MHz) high-gain low-noise amplifier and a 10MHz to 600MHz wideband feedback amplifier are described.

The ISL73096RH, ISL73127RH and ISL73128RH transistor arrays are fabricated in a complementary bipolar bonded wafer silicon-on-insulator (SOI) technology, dubbed UHF-1 [1]. All three products make use of the same die, which has both NPN and PNP transistors on it. Figure 1 shows the pinouts of the three different products. Typical NPN and PNP transistor characteristics are shown in Table 1.

TABLE 1. UHF-1 DEVICE CHARACTERISTIC

PARAMETERS	NPN	PNP	UNITS
BV_{CEO} , MIN	8	8	V
BV_{CBO} , MIN	12	10	V
BV_{EBO} , MIN	5.5	4.5	V
I_{CBO}	0.1	0.1	nA
h_{FE}	70	40	
C_{CB}	500	600	fF
f_T	9	5.5	GHz
P_{1DB} ($I_C = 10mA$, $V_{CE} = 5V$, $f_O = 1GHz$)	7.6	6.2	dBm
IP3 ($I_C = 10mA$, $V_{CE} = 5V$, $f_O = 1GHz$)	17.6	16.2	dBm
NF ($R_S = 50\Omega$, $I_C = 5mA$, $V_{CE} = 3V$, $f_O = 1GHz$)	3.5	3.0	dB

The SOI process has the advantage of lower DC and AC parasitic leakage currents as opposed to junction isolation, which leads to good isolation between transistors. Furthermore, an SOI process provides substantially lower collector to substrate capacitance, immunity to any possible latch-up between the devices, and superior radiation hardness.

The ISL73127RH is used for the two stage matched (800MHz to 2500MHz) high-gain amplifier design, while the ISL73096RH is used for the 10MHz to 600MHz wideband feedback amplifier.

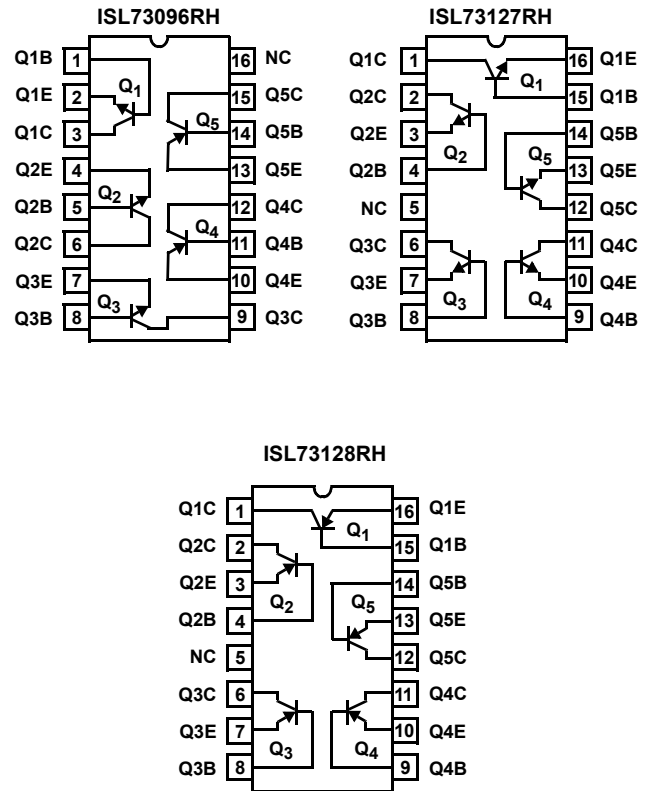

FIGURE 1. PINOUTS OF ISL73096RH, ISL73127RH, ISL73128RH

Circuit Design

High-Gain Low-Noise Amplifier

One important design requirement for an RF amplifier is the accurate control of input and output impedance levels. This is especially important if the amplifier is to interface with matched source and load impedances.

Based on S-parameter measurements, for a common-emitter configuration, transistors of ISL73127RH exhibit a prematched condition on the input side over a wide range of frequencies. The package lead and bond wire inductances for these transistors make the input impedance close to 50Ω . For $I_C = 5mA - 10mA$, $V_{CE} = 2V - 5V$, the input VSWR of Q_2 and Q_5 was less than $-10dB$ for frequencies of 800MHz to 3000MHz. Furthermore, for these transistors, a good output match, output VSWR $< -10dB$ for frequencies 300MHz to 3000MHz, could be accomplished through bypassing the collector with a 100Ω resistor. As the single stage amplifiers built with Q_2 and Q_5 both show good input and output matching, they can be cascaded for higher gain without requiring an impedance transforming network. Figure 2 shows the final two stage amplifier. The advantage of this circuit is its simplicity. This design does not use any tuning inductors or capacitors which would tend to increase the cost of the circuit.

Furthermore, this circuit accomplishes higher gain by cascading two amplifier stages built with integrated transistors.

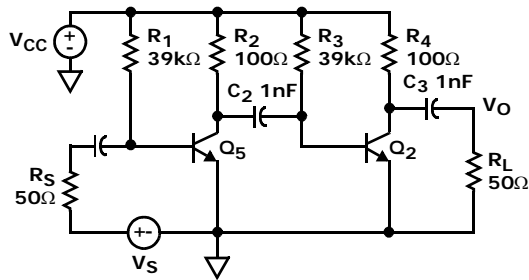

FIGURE 2. HIGH-GAIN LOW-NOISE AMPLIFIER REALIZED WITH ISL73127RH

Figure 3 shows the measured characteristics of the amplifier under two different bias conditions: $V_{CC} = 3V$, $I_{C2} = I_{C5} = 5mA$; and $V_{CC} = 5V$, $I_{C2} = I_{C5} = 10mA$. As can be seen from Figure 3, the input and output VSWR is less than -10dB for frequencies greater than 800MHz. The amplifier shows better performance at the expense of higher power dissipation ($I_C = 10mA$ and $V_{CC} = 5V$) except the noise figure. For $I_{C2} = I_{C5} = 10mA$, the amplifier gains are 18.7, 8.8, and 6.6dB at frequencies of 900MHz, 1800MHz, and 2200MHz, respectively.

From Figure 2, the noise figure of the whole circuit is mainly controlled by the noise characteristics of the transistor Q_5 . As shown in Figure 3D, this high-gain amplifier demonstrates good noise performance. For $I_{C2} = I_{C5} = 5mA$, the measured noise figure is 3.9dB at 900MHz, making this useful as a high-gain, low-noise amplifier.

The complete microstrip board layout is shown in Figure 4. A 0.031 inch thick FR-4 (G-10) glass epoxy board is used for the layout. The dielectric constant of the material is 4.7 at 1000MHz.

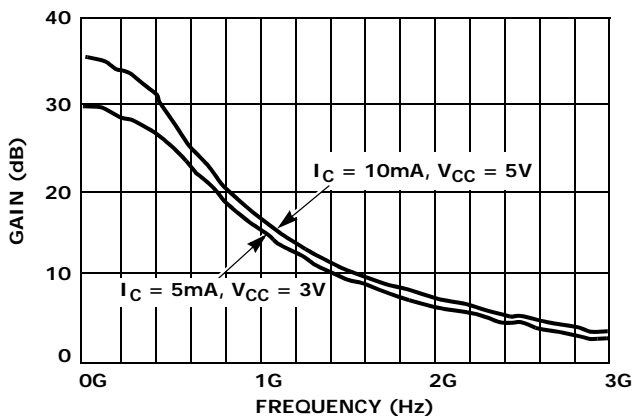

FIGURE 3A. GAIN

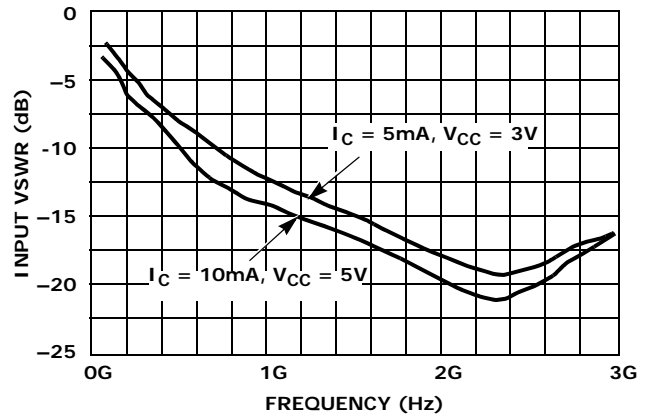

FIGURE 3B. INPUT VSWR

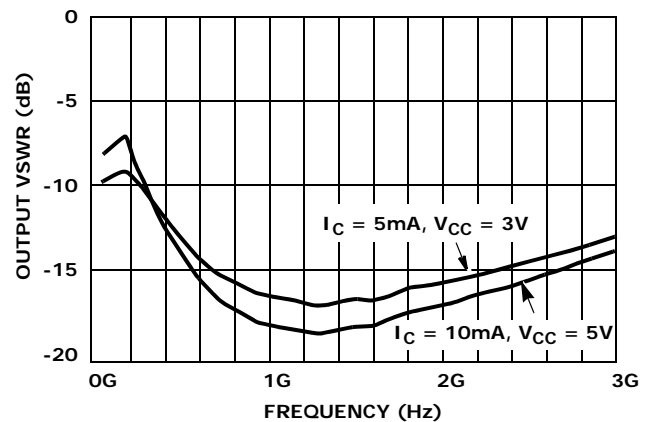

FIGURE 3C. OUTPUT VSWR

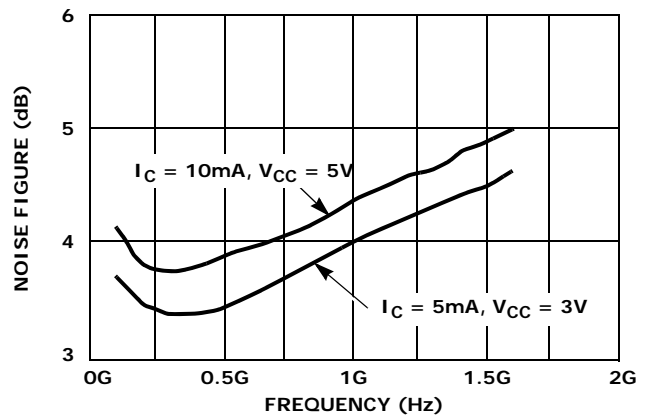

FIGURE 3D. NOISE
FIGURE 3. MEASURED CHARACTERISTICS OF THE HIGH GAIN LOW-NOISE AMPLIFIER

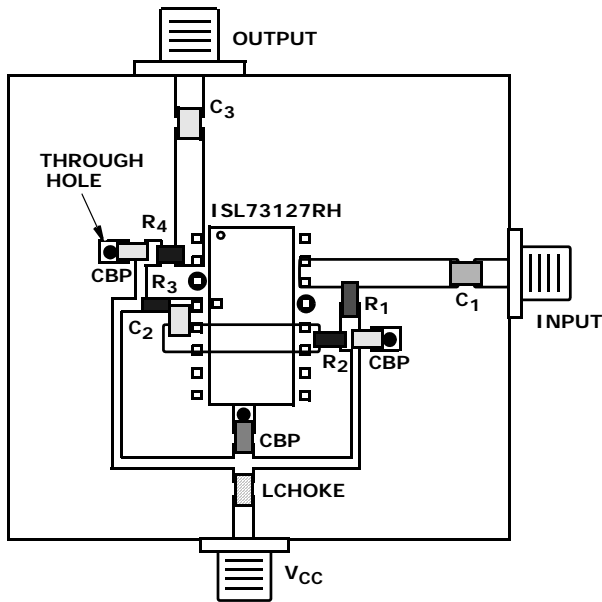

FIGURE 4. MICROSTRIP BOARD LAYOUT FOR THE HIGH-GAIN LOW-NOISE AMPLIFIER

The key rule for the circuit board layout is to make the physical length of the conductors as short as possible where the RF signal is involved. Although it seems obvious, it is easy to forget that the impedance looking into a microstrip line, that has load attached at the end, can be totally different from the attached load impedance depending on the length of the microstrip line and frequency. Outside the RF signal path, it does not matter.

At RF frequencies, the value of chip resistors, capacitors, and inductors should not be taken for granted. In general, the smaller the size of the component, the better the performance. However, it is important to evaluate the components before use. For the RF frequencies, these components can be evaluated easily using a network analyzer by mounting them as shown in Figure 5. The SMA connector itself contributes about 0.7pF of capacitance between the signal and ground terminals.

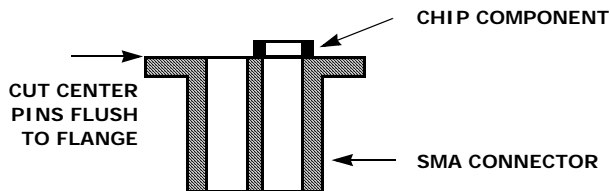

FIGURE 5. A CHIP COMPONENT MOUNTED ON AN SMA

Wideband Amplifier

A well known simple amplifier configuration which achieves flat gain and broadband matching without losing excessive signal power is shown in Figure 6. The simultaneous use of both shunt and series feedback gives rise to broadband resistive input and output impedances [2, 3].

Figure 7 shows a similar version of the double feedback wideband amplifier realized with the ISL73096RH. This design takes advantage of the PNP transistors (Q_4 and Q_5) available on the ISL73096RH, to bias amplifying transistor Q_2 for good temperature stability.

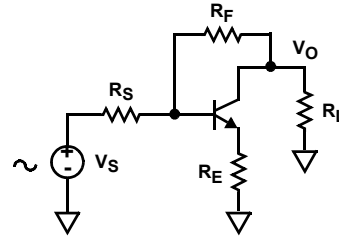

FIGURE 6. SINGLE STAGE SHUNT AND SERIES FEEDBACK

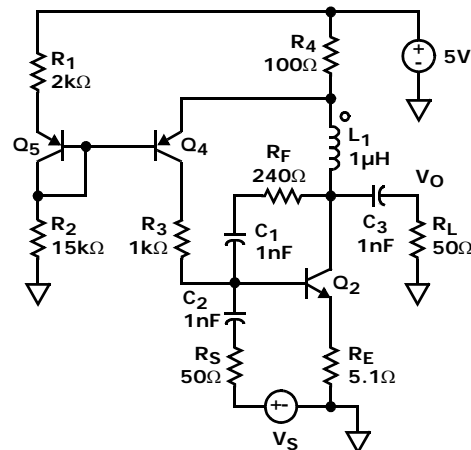

FIGURE 7. WIDEBAND AMP REALIZED WITH ISL73096RH

The frequency response of the wideband amplifier is shown in Figure 8. As can be seen from Figure 8, the amplifier shows 10dB of flat gain with 600MHz bandwidth. The input and output matching is very good over the range of frequency where gains are flat. The low frequency performance is limited by the 1000pF capacitor.

The microstrip board layout for the wideband amplifier is shown in Figure 9. A 0.031 inch thick FR-4 (G-10) glass epoxy board is used for the layout.

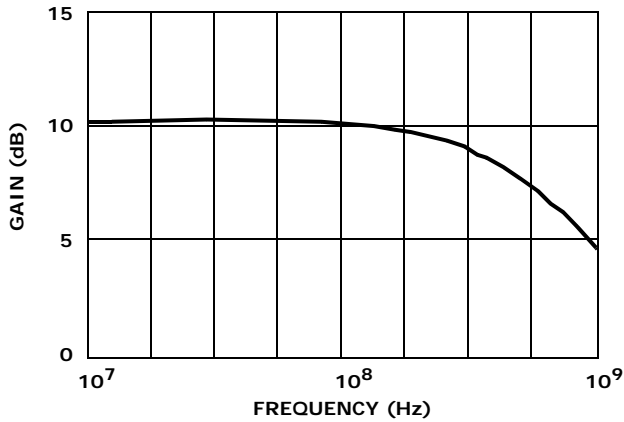

FIGURE 8A. GAIN

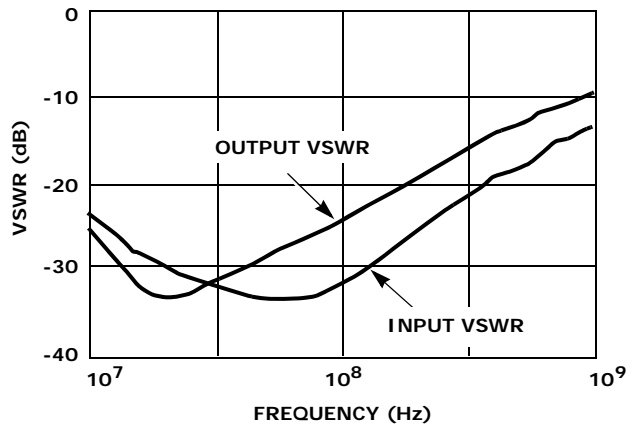

FIGURE 8B. INPUT-OUTPUT VSWR

FIGURE 8. MEASURED CHARACTERISTICS OF THE WIDEBAND AMPLIFIER

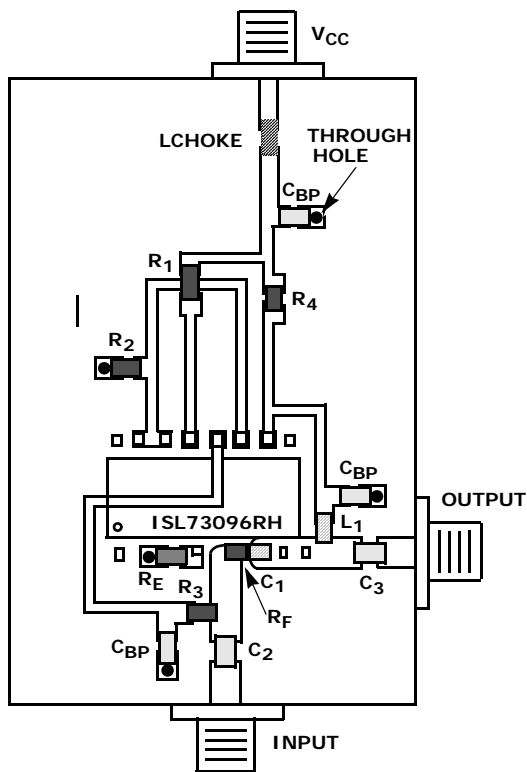

FIGURE 9. MICROSTRIP BOARD LAYOUT FOR THE WIDEBAND AMPLIFIER

Summary

A detailed process of designing a high-gain low-noise and a wideband amplifier using the Intersil UHF transistor arrays is summarized.

A two-stage, high-gain, low-noise amplifier built with the ISL73127RH demonstrates 50Ω input and output impedance over a wide frequency range of 800MHz to 2500MHz without the use of external matching networks. The gain at 900MHz is in excess of 17dB with a noise figure of 3.9dB.

A wideband amplifier built with the ISL73096RH demonstrates excellent input and output matching with 10dB of constant gain. The -3dB bandwidth of this amplifier is 600MHz. PNP transistors available on the ISL73096RH are used for temperature stable biasing of the amplifying transistor.

References

- [1] C. Davis, et al, "UHF-1: A High Speed Complementary Bipolar Analog Process on SOI," Proceeding of BCTM 92, pp260-263, Oct. 1992.
- [2] J. B. Coughlin, et al, "A Monolithic Silicon wideband Amplifier from DC to 1 GHz," IEEE J. Solid-State Circuits, vol. SC-8, pp414-419, Dec. 1973.
- [3] R. G. Meyer, et al, "A wideband Ultralinear Amplifier from 3 to 300 MHz," IEEE J. Solid-State Circuits, vol. SC-9, pp167-175, Aug. 1974.

Notice

1. Descriptions of circuits, software and other related information in this document are provided only to illustrate the operation of semiconductor products and application examples. You are fully responsible for the incorporation or any other use of the circuits, software, and information in the design of your product or system. Renesas Electronics disclaims any and all liability for any losses and damages incurred by you or third parties arising from the use of these circuits, software, or information.
2. Renesas Electronics hereby expressly disclaims any warranties against and liability for infringement or any other claims involving patents, copyrights, or other intellectual property rights of third parties, by or arising from the use of Renesas Electronics products or technical information described in this document, including but not limited to, the product data, drawings, charts, programs, algorithms, and application examples.
3. No license, express, implied or otherwise, is granted hereby under any patents, copyrights or other intellectual property rights of Renesas Electronics or others.
4. You shall not alter, modify, copy, or reverse engineer any Renesas Electronics product, whether in whole or in part. Renesas Electronics disclaims any and all liability for any losses or damages incurred by you or third parties arising from such alteration, modification, copying or reverse engineering.
5. Renesas Electronics products are classified according to the following two quality grades: "Standard" and "High Quality". The intended applications for each Renesas Electronics product depends on the product's quality grade, as indicated below.
"Standard": Computers; office equipment; communications equipment; test and measurement equipment; audio and visual equipment; home electronic appliances; machine tools; personal electronic equipment; industrial robots; etc.
"High Quality": Transportation equipment (automobiles, trains, ships, etc.); traffic control (traffic lights); large-scale communication equipment; key financial terminal systems; safety control equipment; etc.
Unless expressly designated as a high reliability product or a product for harsh environments in a Renesas Electronics data sheet or other Renesas Electronics document, Renesas Electronics products are not intended or authorized for use in products or systems that may pose a direct threat to human life or bodily injury (artificial life support devices or systems; surgical implantations; etc.), or may cause serious property damage (space system; undersea repeaters; nuclear power control systems; aircraft control systems; key plant systems; military equipment; etc.). Renesas Electronics disclaims any and all liability for any damages or losses incurred by you or any third parties arising from the use of any Renesas Electronics product that is inconsistent with any Renesas Electronics data sheet, user's manual or other Renesas Electronics document.
6. When using Renesas Electronics products, refer to the latest product information (data sheets, user's manuals, application notes, "General Notes for Handling and Using Semiconductor Devices" in the reliability handbook, etc.), and ensure that usage conditions are within the ranges specified by Renesas Electronics with respect to maximum ratings, operating power supply voltage range, heat dissipation characteristics, installation, etc. Renesas Electronics disclaims any and all liability for any malfunctions, failure or accident arising out of the use of Renesas Electronics products outside of such specified ranges.
7. Although Renesas Electronics endeavors to improve the quality and reliability of Renesas Electronics products, semiconductor products have specific characteristics, such as the occurrence of failure at a certain rate and malfunctions under certain use conditions. Unless designated as a high reliability product or a product for harsh environments in a Renesas Electronics data sheet or other Renesas Electronics document, Renesas Electronics products are not subject to radiation resistance design. You are responsible for implementing safety measures to guard against the possibility of bodily injury, injury or damage caused by fire, and/or danger to the public in the event of a failure or malfunction of Renesas Electronics products, such as safety design for hardware and software, including but not limited to redundancy, fire control and malfunction prevention, appropriate treatment for aging degradation or any other appropriate measures. Because the evaluation of microcomputer software alone is very difficult and impractical, you are responsible for evaluating the safety of the final products or systems manufactured by you.
8. Please contact a Renesas Electronics sales office for details as to environmental matters such as the environmental compatibility of each Renesas Electronics product. You are responsible for carefully and sufficiently investigating applicable laws and regulations that regulate the inclusion or use of controlled substances, including without limitation, the EU RoHS Directive, and using Renesas Electronics products in compliance with all these applicable laws and regulations. Renesas Electronics disclaims any and all liability for damages or losses occurring as a result of your noncompliance with applicable laws and regulations.
9. Renesas Electronics products and technologies shall not be used for or incorporated into any products or systems whose manufacture, use, or sale is prohibited under any applicable domestic or foreign laws or regulations. You shall comply with any applicable export control laws and regulations promulgated and administered by the governments of any countries asserting jurisdiction over the parties or transactions.
10. It is the responsibility of the buyer or distributor of Renesas Electronics products, or any other party who distributes, disposes of, or otherwise sells or transfers the product to a third party, to notify such third party in advance of the contents and conditions set forth in this document.
11. This document shall not be reprinted, reproduced or duplicated in any form, in whole or in part, without prior written consent of Renesas Electronics.
12. Please contact a Renesas Electronics sales office if you have any questions regarding the information contained in this document or Renesas Electronics products.
(Note 1) "Renesas Electronics" as used in this document means Renesas Electronics Corporation and also includes its directly or indirectly controlled subsidiaries.
(Note 2) "Renesas Electronics product(s)" means any product developed or manufactured by or for Renesas Electronics.

(Rev.4.0-1 November 2017)



SALES OFFICES

Renesas Electronics Corporation

<http://www.renesas.com>

Refer to "<http://www.renesas.com/>" for the latest and detailed information.

Renesas Electronics America Inc.
1001 Murphy Ranch Road, Milpitas, CA 95035, U.S.A.
Tel: +1-408-432-8888, Fax: +1-408-434-5351

Renesas Electronics Canada Limited
9251 Yonge Street, Suite 8309 Richmond Hill, Ontario Canada L4C 9T3
Tel: +1-905-237-2004

Renesas Electronics Europe Limited
Dukes Meadow, Millboard Road, Bourne End, Buckinghamshire, SL8 5FH, U.K
Tel: +44-1628-651-700, Fax: +44-1628-651-804

Renesas Electronics Europe GmbH
Arcadiastrasse 10, 40472 Düsseldorf, Germany
Tel: +49-211-6503-0, Fax: +49-211-6503-1327

Renesas Electronics (China) Co., Ltd.
Room 1709 Quantum Plaza, No.27 ZhichunLu, Haidian District, Beijing, 100191 P. R. China
Tel: +86-10-8235-1155, Fax: +86-10-8235-7679

Renesas Electronics (Shanghai) Co., Ltd.
Unit 301, Tower A, Central Towers, 555 Langao Road, Putuo District, Shanghai, 200333 P. R. China
Tel: +86-21-2226-0888, Fax: +86-21-2226-0999

Renesas Electronics Hong Kong Limited
Unit 1601-1611, 16/F., Tower 2, Grand Century Place, 193 Prince Edward Road West, Mongkok, Kowloon, Hong Kong
Tel: +852-2265-6688, Fax: +852-2886-9022

Renesas Electronics Taiwan Co., Ltd.
13F, No. 363, Fu Shing North Road, Taipei 10543, Taiwan
Tel: +886-2-8175-9600, Fax: +886-2-8175-9670

Renesas Electronics Singapore Pte. Ltd.
80 Bendemeer Road, Unit #06-02 Hyflux Innovation Centre, Singapore 339949
Tel: +65-6213-0200, Fax: +65-6213-0300

Renesas Electronics Malaysia Sdn.Bhd.
Unit 1207, Block B, Menara Amcorp, Amcorp Trade Centre, No. 18, Jln Persiaran Barat, 46050 Petaling Jaya, Selangor Darul Ehsan, Malaysia
Tel: +60-3-7955-9390, Fax: +60-3-7955-9510

Renesas Electronics India Pvt. Ltd.
No.777C, 100 Feet Road, HAL 2nd Stage, Indiranagar, Bangalore 560 038, India
Tel: +91-80-67208700, Fax: +91-80-67208777

Renesas Electronics Korea Co., Ltd.
17F, KAMCO Yangjae Tower, 262, Gangnam-daero, Gangnam-gu, Seoul, 06265 Korea
Tel: +82-2-558-3737, Fax: +82-2-558-5338