

Extending the KVM Video Range to 1.5k Ft

The present KVM extension solution, Intersil's 'Hermes' board, support RGB video transmission down Cat 5 cable to about 1,000ft. Yet, you can extend this solution to 1,500ft by simply adding a pre-compensation network cable driver. This pre-comp driver is inserted between the EL4543 line driver RJ45 output plug and the Cat 5 cable to extend the range by 500ft (refer to Figure 3). We will also offer an option which you can connect directly to the computer's VGA video output plug to extend the range of the PC's RGB output on Cat 5 cable.

Problem

Cat 5 is not an ideal transmission medium for video yet, is very economical vs using RG-59 Coax. The present KVM solution used the EL4543 which embeds the H_{SYNC} and V_{SYNC} as a difference common mode signal onto the RGB line pairs. The embedding of the syncs reduces the cable requirement to just three twisted wire pairs in a Cat 5 cable bundle of four wire pairs. The present KVM solution is good to about 1,000ft and uses the EL9111 or three EL9110s to receive and extract the H_{SYNC} and V_{SYNC} from the RGB. Yet, the longer the Cat 5 cable, the more the signal losses of the higher frequencies. For a flat frequency response needed for video, the cable will need compensation. Cat 5 cable losses are about 3dB per decade so simple RC passive circuits to boost the HF components will not compensate for such losses. How then is the range extended by 500ft?

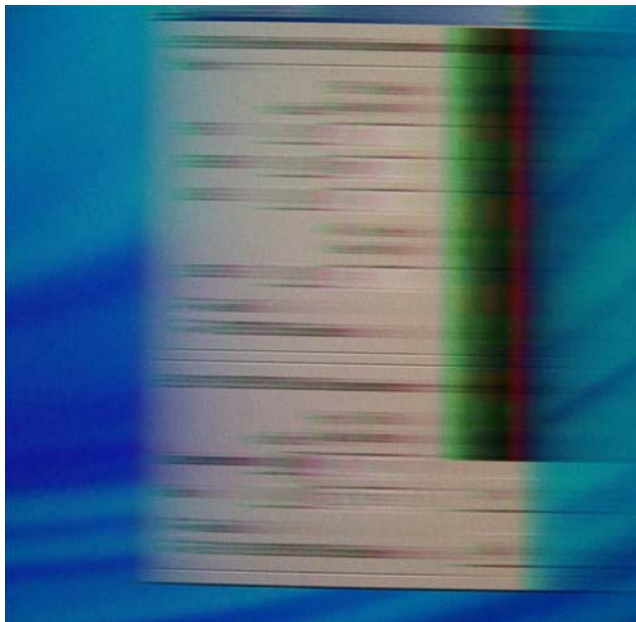

FIGURE 1. RGB DOWN 1,500ft CAT 5 NO COMPENSATION

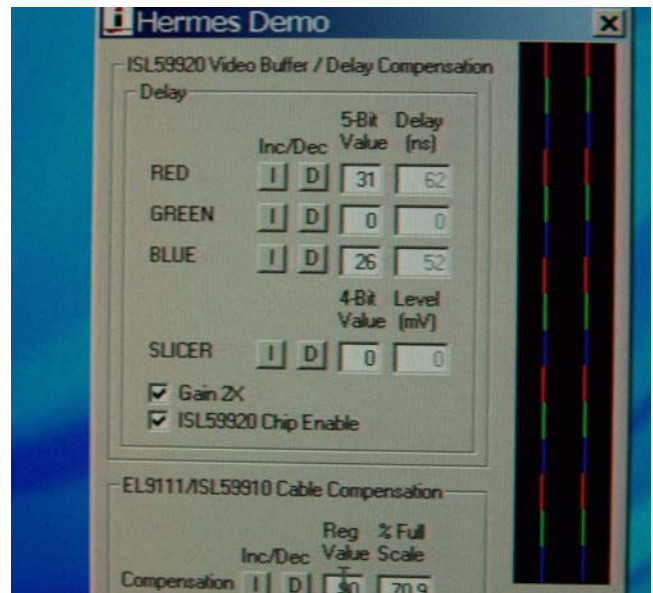

FIGURE 2. HERMES' BOARD COMPENSATION WITH THE 5009' DRIVER EXTENTION

Solution

This application note will address using active peaking circuitry at the driving end of the Cat 5 cable to extend the usable range an additional 500ft. The same peaking circuit can be used to extend standard RGB output from a PC up to 500ft as well. Key is insuring the high frequency elements, such as the H_{SYNC}, V_{SYNC} and color information are peaked in such a manner to overcome Cat 5 cable losses. This design is done in the analog domain to maximize the overall performance at the lowest cost.

We will discuss one channel, the other 2 channels will need to be replicated for a complete RGB system.

The Amplifier

The amplifier peaks the incoming RGBHV of the EL4543 and drives the long distance Cat 5 cable (See Figure 4). To accomplish this, we will need to complete the following steps:

1. Impedance match the incoming Cat 5 to the peaking network.
2. Adjust the sync CMV level to within the input range of the Amp to optimize its operation.
3. Add peaking circuitry to correct sync offset rising and falling edges due to the CMV offset circuit.
4. Peak the three critical portions of the signal, which are the Flatness, High Frequency components and the DC Gain level

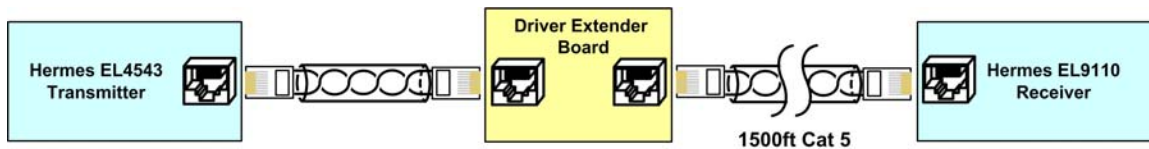

FIGURE 3. PLACEMENT OF THE DRIVER EXTENDER BOARD

Basic Overall Circuit Description

The compensation circuitry needs a very high BW to provide the gain for the high frequency elements of the incoming video signal. We selected the EL5378 Triple 700MHz Differential Twisted-Pair Driver as the basis for the incoming amplifier and peaking network. Key for its selection is the wide bandwidth and unique differential input structure and its external reference input. This unique input structure isolates the input from the feedback network, greatly reducing design problems. We can set the Gain and Offset without being concerned about how they would negatively impact the input video signal.

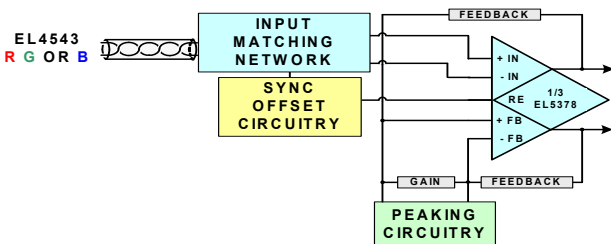

FIGURE 4. BASIC BLOCK DIAGRAM OF THE CIRCUIT

EL4543 RGB with Differential CMV Sync Encoded

The EL4543 is normally used as a 0V to 5V video amplifier with the output offset to half the supply voltage of 2.5V. The EL5378 must be used at $\pm 5V$ to allow for the frequency peaking voltage output range. Thus, the output of the EL4543 must be offset to match the 0V input need for the EL5378. If the EL4543 is used at $\pm 5V$, then the output has no offset and the offset circuit can be set for 0V offset with a switch.

INPUT MATCHING NETWORK

(Refer to Figure 6) The incoming R, G or B video is a differential signal. Once the differential signal is properly matched and adjusted to the input of the EL5378 (Input Matching Network), the signal will require a 2x gain to compensate for the output cable termination loss of the EL5378. The EL5378 is a differential amplifier and to set the gain will require the classic two feedback resistors from the outputs to the feedback pins and a gain resistor between the feedback pins.

SYNC OFFSET CIRCUITRY

The peaking circuitry needs to be applied to the R, G or B incoming signals separately. The H_{SYNC} and V_{SYNC} are encoded on the R, G and B differential signal lines by the EL4543. The encoded H_{SYNC} and V_{SYNC} will need to be

recovered and repled as a common mode voltage (CMV) to the amplifier insuring the CMV range of the amplifier is optimized.

The Sync Offset circuit will also reduce the sync amplitude by 1/3 due to the series 1k and 2k resistors, thus requiring modification of the gain in order to peak the syncs leading and trailing edge and recover the sync amp.

Peaking Circuit

The Cat 5 cable signal losses are at a higher frequency. For a flat frequency response needed for video, the cable will need compensation. Cat 5 cable losses are about 3dB per decade. Thus, simple RC passive circuits will not work.

Even though the video signal has gained up to recover the termination loss, there is a need to selectively peak the gain for certain bandwidths as the Cat 5 cable effects different frequency bands differently. Thus, developing a peaking/frequency boost network to compensate for this effect. The peaking network is connected across the gain resistor to adjust the gains at different frequencies.

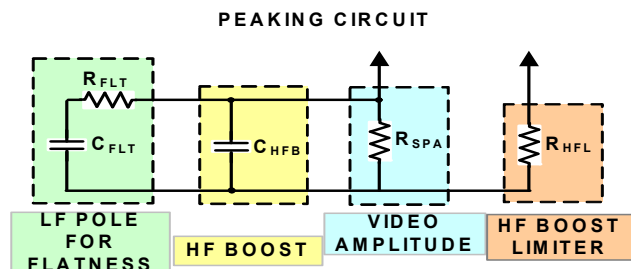

FIGURE 5. PEAKING CIRCUITRY

The peaking network selected, is a classic configuration with separate R, C and RC elements to modify the gain for Flatness, HF Boost and Video Amplitude. The single capacitor, C_{HFB} will peak the highest frequencies and the network gain resistor controls the peak gain/sharpness. The additional series RC network, R_{FLT} and C_{FLT} form the low frequency pole to determine the flatness of Back Porch. The last resistor to ground, R_{SPA} , determines the height of the low frequency video. We added R_{HFL} to gain limit the HF Boost for stability and reduce HF noise.

The Peaking circuit is parallel to the DC gain resistor which modifies the overall gain of the amplifier to generate a flat frequency response needed for video. You can break down the video requirements into four different parts (refer to Figure 5):

1. **SYNC Flatness** – The Back Porch flatness sets the overall luminance reference for the horizontal scan.

Using a simple low frequency pole to peak the gain at low frequencies ensures the received back porch at the other end of the cable will be reasonably flat. A simple series RC forms the low frequency pole.

2. **HF Boost** – Since the Cat 5 cable has greater losses at higher frequencies, we use a capacitor to peak the gain at high frequencies.
3. **Video Amplitude** – A simple resistor can insure we have correct gain. Why not just use one resistor to set the DC gain? We will explain our reasoning in the following sections.
4. **Limit HF Boost** – We use a small value resistor to reduce the effect of the peaking circuit on the summing node of the EL5378. This resistor will limit the HF Boost, prevent the circuit from going into oscillations, and help reduce the HF noise from being amplified. A small series resistor is used to reduce the effects of any capacitance you may have on the summing node and their effects. More on this topic is discussed later in this application note.

Detail Circuit Description

Input Matching Network (Figure 6)

The input network is set up to terminate the Cat 5 cable impedance with two 51Ω resistors in series across the cable for a 100Ω load match. We use two series resistor to establish a mid point for Sync Extraction.

SYNC Extraction w/Offset Adjust

We can use the midpoint of the two resistor termination and extract the common mode Syncs. We can also use the same node to apply the required CMV adjustment.

The encoded H_{SYNC} and V_{SYNC} are recovered by the 1k resistor parallel with the 0.1μF capacitor to the 51Ω mid point. If the EL4543 is operating in single supply mode, +5VDC, the CMV point will be at 2.5VDC. In turn, the EL5378 operates with a dual supply of ±5V and its common mode zero point is at 0VDC. Thus, we must have the REF input and the DIFF output at 0V average. To accomplish this, we need to offset the incoming Sync by -2.5VDC to force Syncs CMV to match the EL5378s CMV. We can connect a 1k resistor from the termination

mid point in series with a 2k resistor terminated at -5V, to offset the Sync by -2.5VDC. If the source (EL4543) is operated at ± 5V, then the offset is not needed and the 2k resistors should be connected to ground. A universal option is given by using switch S1, see Figure 1, to connect the 2k resistors to ground or -5V. The 1k and 2k induce a 1/3 loss of the sync signal amplitude but the 0.1μF capacitor will give the edges a full level signal so that no useful sync signal is lost.

Peaking Circuit

Even though the video signal has been gained up, certain bandwidths need to be selectively peaked as the Cat 5 cable effects different bands differently. It is then necessary to develop a peaking/frequency boost network to compensate for the cable effect. The discussion on ng how to design this circuit will not be discussed, however, we will mention how it works. The key point to remember is that each of the peaking networks is additive.

LIMITING THE HF BOOST

The EL5378 is not truly a 2x gain amp due to stray PCB capacitance impacting the HF frequency gain. This small stray capacitance will peak the gain at other higher frequencies. It is near impossible to remove all the stray capacitances but it is possible to reduce the stray capacitance. However, this stray capacitance will cause the gain to be peaked at other than the desired frequencies. By placing a small resistor after the selection switch (see Figure 6) close to the summing node, will act as an isolation resistor to the stray capacitance by reducing the overall Q of the parasitic capacitors. The reasoning for being concerned about stray capacitance is the more capacitance you have on the summing node the more unstable the wide band amplifier becomes. Make sure to place these resistors very close to the summing node, to further reduce the stray capacitance of the PCB trace between the resistor and the node. Also, for the components that form the summing node, keep the physical distance to a minimum. As for the basic layout guidelines, use a good ground plane and a ground plane moat under the summing node and the network RCs to help reduce noise and stray PCB capacitances.

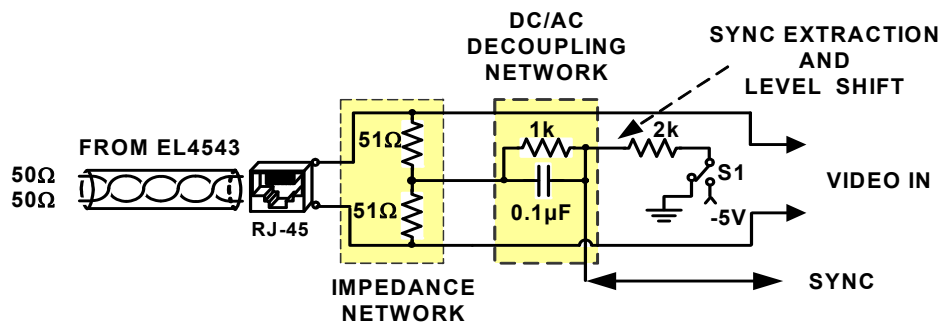

FIGURE 6. INPUT IMPEDANCE MATCHING NETWORK

Improved Design Using Selectable Range 150ft, 300ft and 450ft (150ft + 300ft)

This design covers from 1,000ft to 1,500ft. Yet, it does require trade-offs if implemented in a single peaking circuit. The high frequency losses of the Cat 5 cable changes dramatically as the cable length increases. Yet, if the peaking circuits are optimized for a given increment of Cat 5 cable length, the networks are able to be connected in parallel, compensating the driver for different cable runs as needed. By dividing the additional 500ft into two, 1/3 and 2/3's, we can we can optimize the peaking for each length, improving the overall performance. Now, using superposition, the two different peaking circuits are able to be added, achieving an overall length of 450ft.

Range selection can be done by using a simple low capacitance mechanical SPST switch. A simple selector switch will give us the flexibility to use this circuit in many applications for cable lengths from 1,000ft to 1,150ft to 1,300ft to finally 1,450ft with minimal degradation in the video signal.

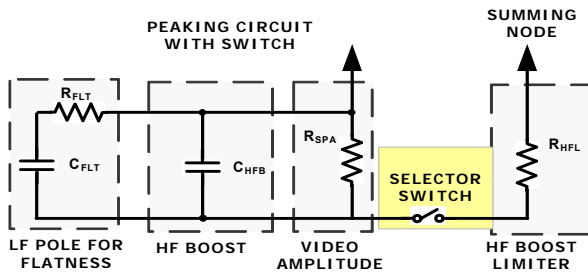

FIGURE 7. SELECTOR SWITCH PLACEMENT

At this point, we have gone through the quantitative experimentation and have come up with our recommended values for the peaking circuit components. To help isolate these stray capacitances, the switches should be connected upstream of the peaking network, before the HF Boost Limiter resistor and closest to the In-Amp's summing node right at the gain resistor.

The peaking circuit is designed to peak the desirable HF elements by using an edge enhancement HF Boost RC network, a parallel H_{SYNC} pulse flatness RC network, a parallel DC video amplitude network and a switch to add peaking as function of the cable length. The peaking circuit is designed to peak the desirable HF elements by using an edge enhancement HF Boost RC network, a parallel H_{SYNC} pulse flatness RC network, a parallel DC video amplitude network and a switch to add peaking as function of the cable length (see Table 1).

TABLE 1. TYPICAL PEAKING NETWORK VALUES BY CAT 5 CABLE LENGTH

CAT 5e	FLATNESS		HF BOOST	SYNC TIP	HF BOOST LIMITER
	R _{F_{LT}} (kΩ)	C _{F_{LT}} (pF)	C _{H_{GB}} (pF)	R _{S_{PA}} (kΩ)	R _{H_{FL}} (Ω)
150	5	75	20	34	510
300	2	130	47	16	255
500	1.43	200	68	11	170

Test Results

There is the same image at 1500ft with the hermes board and the extender circuit. Using the Herme's design and extended board full range compensation, you can see in Figure 8, the images are very useful.

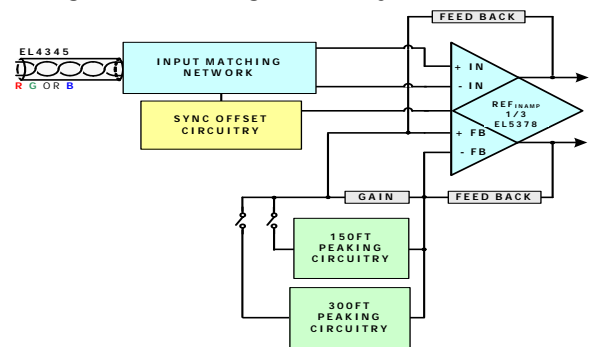

FIGURE 8. COMPLETE BLOCK DIAGRAM

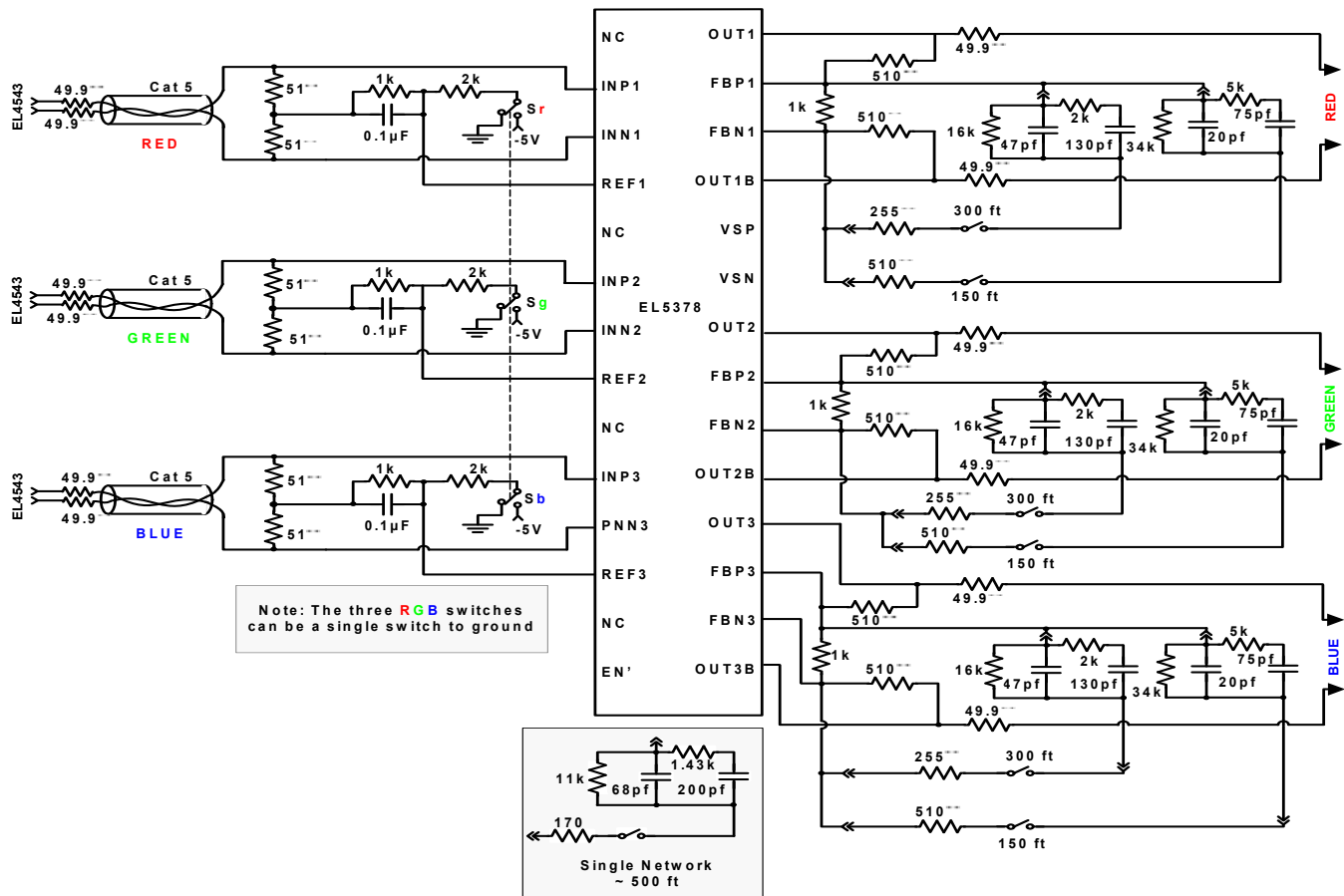

FIGURE 9. COMPLETE RGB EXTENDER CIRCUITRY

Extending the RGB+HVsync Output from Your PC

We can use the same peaking network to also extend the RGBHV from your PC by simply encoding the H_{SYNC} and V_{SYNC} as is done in the EL4543 but do it discreetly using simple digital NAND gates (74HC00). We will also need to encode, then offset and scale these signals so they can be added on the R, G and B as we did in the previous circuit (Refer to Figure 10).

STD LEVEL BUFFER AND ENCODER

The buffer will shift the input levels to a simple logic level for the logic encoding. We can use a simple HCMOS logic device to perform both the Level Buffer and the Encoding.

OFFSET ADJUST AND SCALER

We need to offset this ground reference logic level Syncs to a common mode voltage average of 0V. Thus, as with the previous circuit, we will need to offset the Syncs negatively to remove the DC offset from the logic device output.

Extending the RGB + HV_{SYNC}

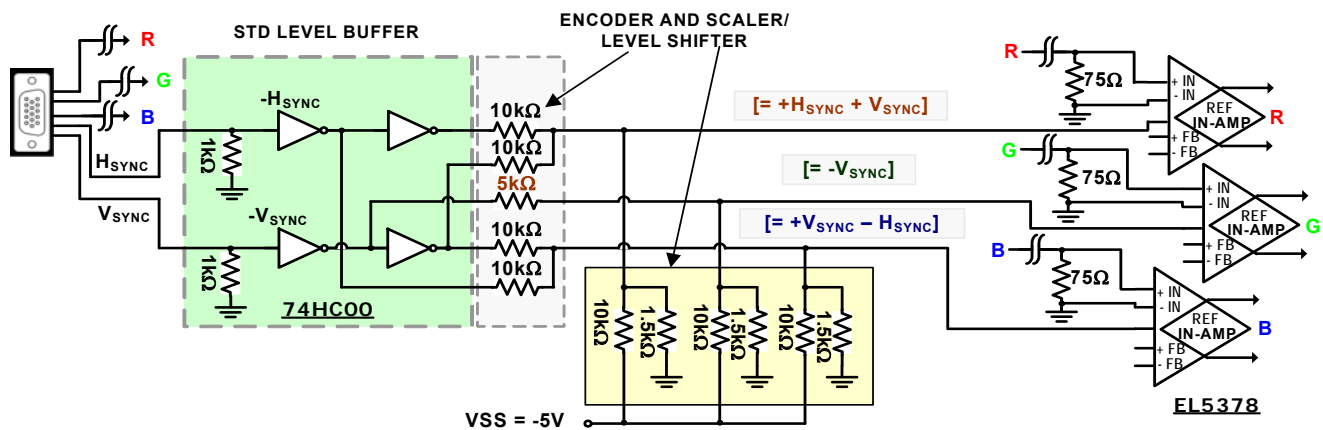

FIGURE 10. DETAILED PC RGB EXTENDER

Circuit Details

STD Level Buffer (Figure 10)

The H_{SYNC} and V_{SYNC} coming from the PC are referenced to ground using a 1kΩ resistor as a standard load. We use a very low cost logic gate, such as the HC00 on the H_{SYNC} and V_{SYNC} inputs, setting to known levels as source to the encoding. The outputs are H_{SYNC} and V_{SYNC} both inverted and non-inverted.

Encode

We need to buffer the input to the Ref of the EL5378. We use 10kΩ series resistors at the output of the buffers to prevent these outputs from loading each other and at the same time properly encode the H_{SYNC} and V_{SYNC}. The output of each is 5k in order to simplify the configuration. Now we have encoded the output of the buffers to the Sync sum/differences as generated internally by the EL4543.

Offset and Scale

Scaling and level shifting of the Syncs is done in one simple resistor divider. Using a simple resistor divider network tied to -5VDC, we can offset each Sync combinations as needed before applying them to the EL5378 Reference inputs. Reference Inputs are as follows:

RED [+ H_{SYNC} + V_{SYNC}]

GREEN [- V_{SYNC}]

BLUE [+ V_{SYNC} - H_{SYNC}]

Figure 10 shows that, all the buffer outputs resistor networks have the same 5k output impedance and the 10k to -5V. This gives us a 0V output with ±1.66V sync levels at 3.33k source and with 1.5k to ground giving ±0.5V sync output levels to the Ref.

The H_{SYNC} and V_{SYNC} are now properly encoded matching the encoding scheme of the EL4543. The encoded Syncs are applied to the V_{REF} of the EL5378. Thus, the PC RGB signals are single ended outputs. The VGA cable RGB lines are connected to a 75Ω termination resistor and the INP inputs of the EL5378 and the INN inputs to ground. This configuration with the 75Ω termination resistor will properly terminate the video signal. We still need to keep the 2x gain to overcome the termination loss.

RGB pairs have no standard cable pin out so be sure you use the same cable pin out as your receiver.

Cable pinout for cat 5 RJ45 input board design should be correct to insure the sync is on the correct color line so the sync decode will work.

The cable pin out used is the same as used on the Intersil EL4543 'HERMES-DEMO-BOARDZ'.

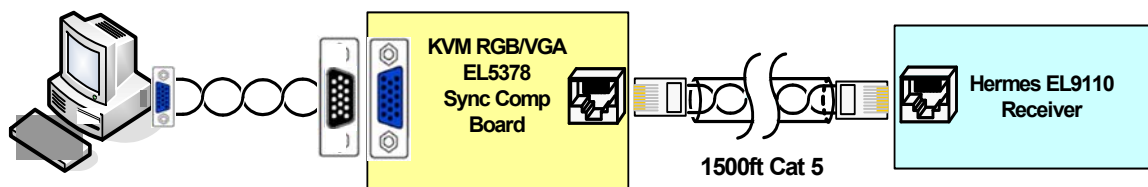

FIGURE 11. PLACEMENT OF THE RGB/VGA SYNC COMPENSATION BOARD

Notes to Consider

1. RGB pairs have no standard cable3 pinout. So be sure you use the same cable pinout as your receiver.
2. Cable pinout for Cat 5 RJ45 input board design should be correct to insure the Sync is on the correct color line. Otherwise, the sync decode will not work.
3. The cable pinout used is the same as used on the Intersil EL4543 HERMES-DEMO-BOARDZ, see Figure 12.

Test Results

1. Results for experimentation and testing: The video band width is about:
 160MHz at the 150ft range
 110MHz at the 300ft range
 85MHz at the 450ft range

These test results are similar to the EL9111 at max range of 1000ft.

2. Cat 5E cable skew starts to show up at about 300ft. We recommend the use of a deskew IC like the EL9115 or ISL59920 for Cat 5E cables greater than 300ft.

Complete Schematic and PCB Layout

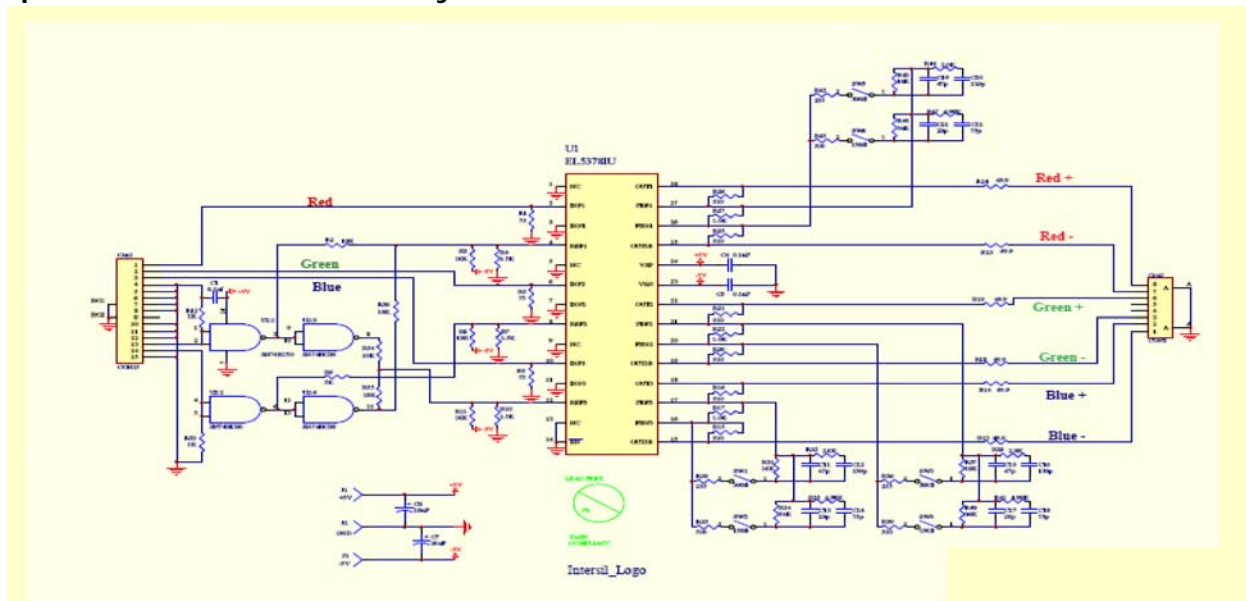

FIGURE 12. KVM RGB w/CMV SYNC-CABLE COMPENSATION SCHEMATIC

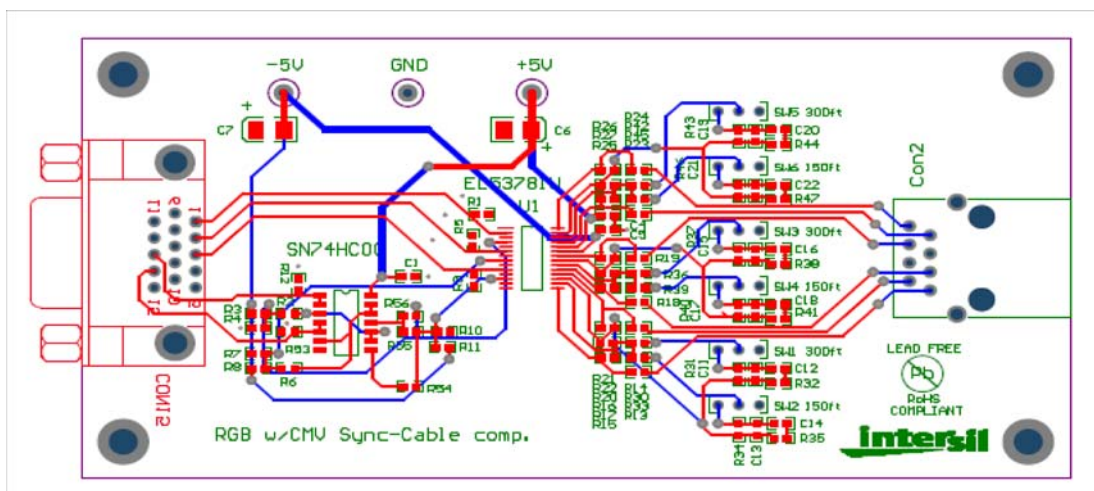

FIGURE 13. KVM RGB w/CMV SYNC-CABLE COMPENSATION PCB LAYOUT

Appendix

Cat 5 cable pair Video color selection Problems and Solutions:

Problem - The cat 5 cable pairs have different twist rates to reduce the crosstalk. However, the different twist rates causes the prop delay to be different for each pair. Using the pairs for good color video reproduction requires the colors arrive at the same time so they will align with each other. The different twist rates causes the colors to arrive at the monitor at different times. The result is having three different color images next to each other.

Solution for Deskew ICs - To optimize the performance of the deskew IC, select the wire pairs to minimize the RGB skew caused by the cable's different twist rates. Our testing has shown that the skew is about 24ns to 32ns for nearest skew pairs. Three twisted wire pairs have been tested at the standard Cat 5 RJ45 pins. The wire pairs associated with pin pair 1–2 is the shortest pin pair 3–6 is the middle and pin pair 7-8 is the longest.

Recommendations

For optimum performance, we recommend the shortest pair (pins 1–2) to be the Blue signal, which will require the longest delay. The Green (pins 7-8) should be the longest pair and be the reference or zero delay, thus, needing no correction. Then, the middle, Red (pins 3–6). The selection for the RED and Green pairs is not very critical when using a deskew IC but the Blue wire pair should have the longest delay.

DeSkew Solution

There are a number of applications where added deskew is needed. Such as, when a Hermes type KVM receiver cable comp board is used and a cable longer than 1000ft is needed, then a pre comp cable driver can be used but more deskew will be needed. By designing an IC deskew board unit with computer (VGA cable plugs on the input and output and a USB plug) then it can be added to the output of an existing cable receiver to get the needed deskew added. The deskew unit can be connected to the input of the pre comp cable driver. This will allow an extra long cable to be added to a working system. For new systems the extra IC de skew chip can be designed in as needed.

Another application for a deskew unit is for shorter up to 500ft cable using the EL4543 as a cable driver and the application note in the data sheet using the EL5375 used as the cable comp receiver.

Add Deskew to New Receiver Design

The extra skew from the added 500ft of cable should be corrected at the cable receiver if possible. It will be easier to implement at the receiver.

The deskew IC is best placed just before the receiver VGA plug at the output to the monitor. The RGB lines are separated from the embedded H_{SYNC} and V_{SYNC} so just the RGB is available at the VGA plug.

Adding 500' Cat 5 Skew Problem - A Low Cost Work Around

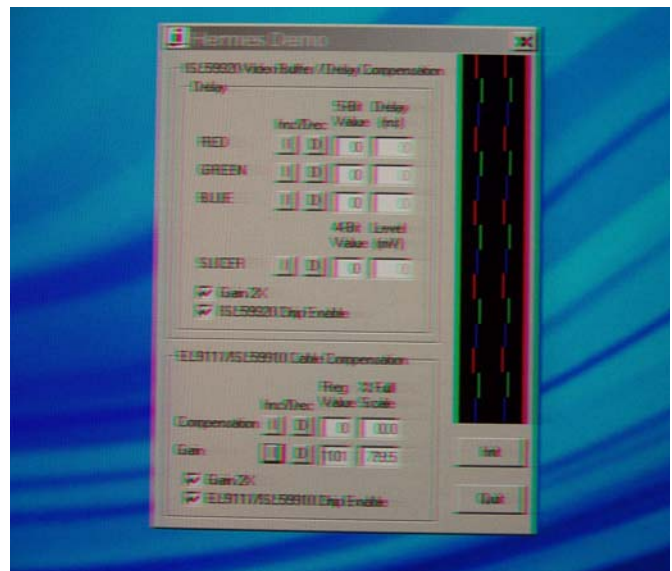

FIGURE 14. SKEW AT 500' NO COMPENSATION

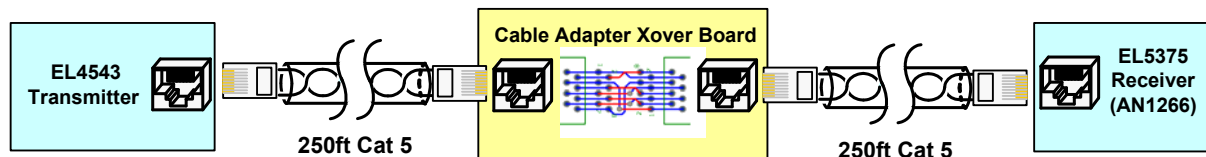

FIGURE 15. PLACEMENT OF THE CABLE CROSSOVER BOARD

Notes:

1. Most of the skew may be canceled by using two 250ft alike Cat 5 cables in series to make 500ft cable. At the middle of the 500ft cable, you swap the longest and shortest video lines and at the receiver swap them back.
2. When a deskew IC is used in the system with over 1k feet then the two cables can be of different length, as long as the deskew IC can correct the difference in the two cable lengths. A 1k feet cable with 500ft cable with longest and shortest video pairs reversed at both ends of one cable, will have only 500ft of skew remaining that the deskew IC can correct.
3. Cable adapter boards, see Figures 16 and 17, may be used to rearrange the color pairs with existing systems to get better color performance with the KVM extender at 1500ft to optimum color pair assignments. When an added deskew IC is not used then there will be blue color error but generally will be small. This will give a low cost solution with good performance to about 1300ft and reduced performance at 1500ft on Cat 6 cable.

The cable adapter cable wiring crossover will need to be designed as needed for the application. The adapter crossover shown is for Hermes improved pair selection.

The cable adapter board may be configured for color pair long to short pair reversal. The same adapter is used in the middle and one end of the cable and just reversed in direction. The "Cable" labels should go to the same cable.

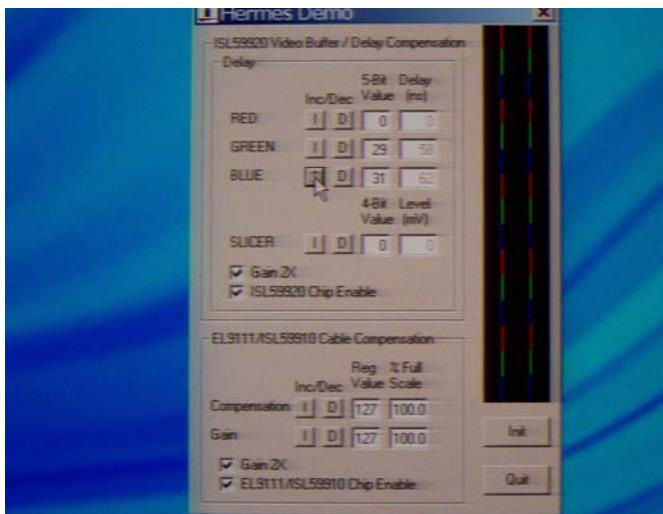

FIGURE 16. 500' WITH THE ADAPTER BOARD

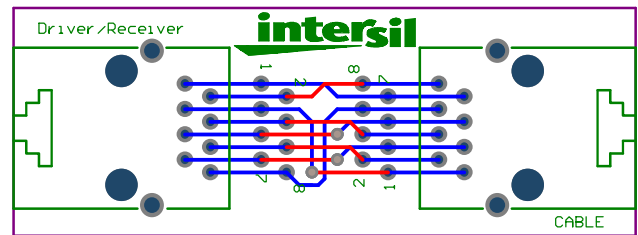

FIGURE 17. CABLE ADAPTER BOARD

Dielectric Cable Smear (Dielectric Storage Effect)

If you look close at Figure 18, you will see a smearing to the right of any Dark to Light or Light to Dark color transition. This is referred as a cable smear, the result of the twisted wire insulation dielectric absorption.

The rise time of the cable causes short time constant smear that is corrected with cable compensation. However, the dielectric insulation in the cable has dielectric absorption that causes electrons to be stored in the dielectric. When there is a voltage across the dielectric, the electrons are not just on the surface but go into the dielectric and are stored there. Therefore, when the voltage is removed, the electrons are slowly released. In a long cable that is at one voltage for a number of micro seconds followed by a larger voltage change, there is a charge or discharge of the electrons that changes the voltage on the cable that shows up as a long time constant of a number of micro seconds of smear. This can only be fixed by a low dielectric absorption cable.

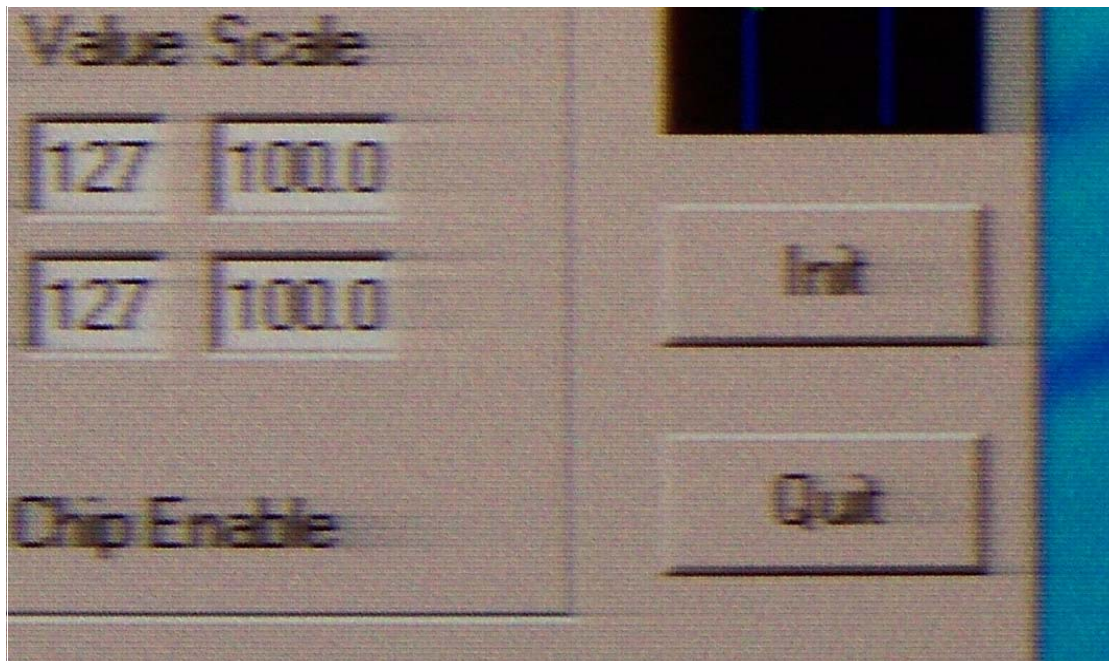

FIGURE 18. EXAMPLE OF CABLE SMEAR

ESD Protection

Figure 19 does not have ESD protection shown. ESD protection should be added as needed with a Schottky diode, we recommend the BAT54S dual diode be connected from the plus and minus supplies to the output and input cables. Transit Voltage Suppressors should be added if the cables are exposed outdoors. The placement should be close to the first IC encountered from the input of the receiver. For short runs this would be the input to the EL537x and for long runs requiring deskew, this would be the input to either the EL9115 or ISL5992x.

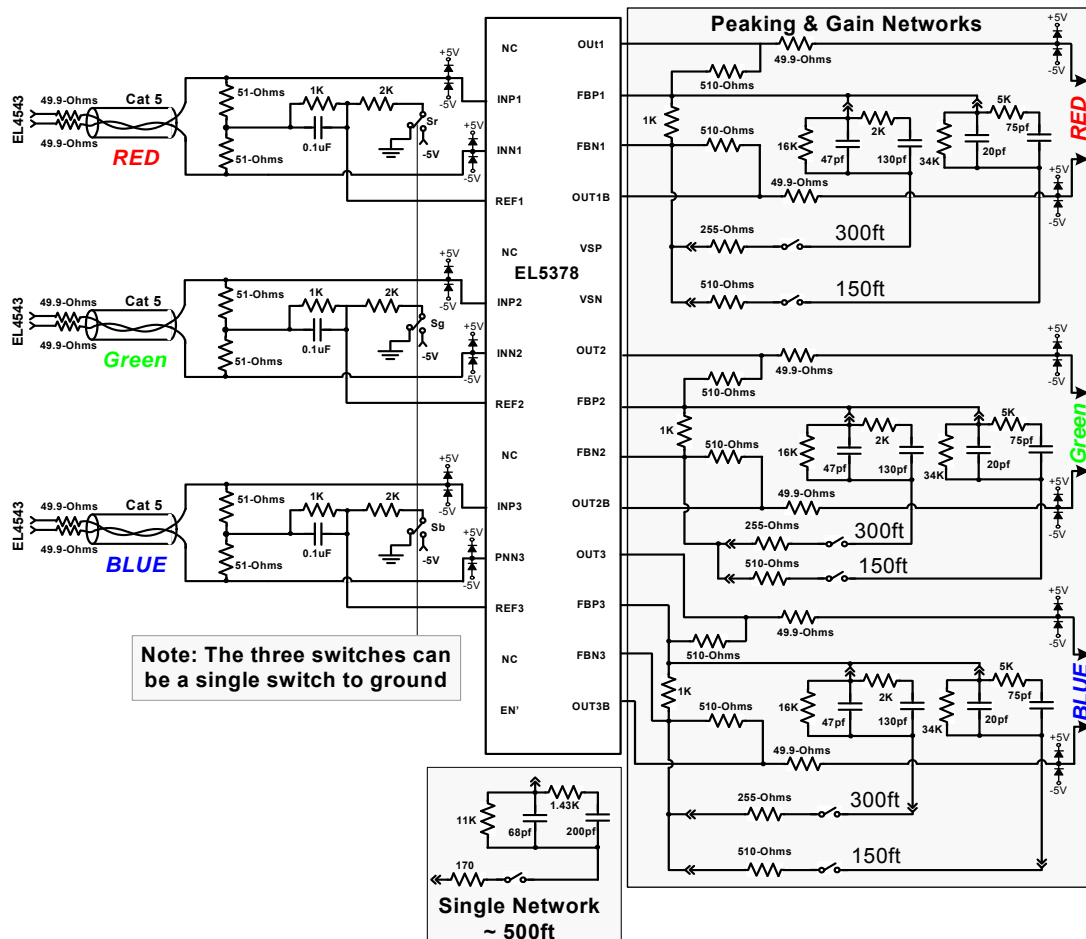

FIGURE 19. COMPLETE COMP CIRCUITRY WITH ESD PROTECTION

Add De-Skew to New Pre Comp Driver

When the cable receiver does not have the range to correct the added skew, and the added deskew cannot be added at the receiver, then the additional correction can be added at the cable driver end. The Cat 5 cable has a fourth digital control wire pair which can control the logic from a USB port, for a remote deskew IC at the cable driver. You can now control the deskew from the remote KVM station using the fourth cable pair for the deskew logic control.

The deskew IC is then connected from the of the VGA board input to the RGB input of the EL5378. The 75Ω termination resistor stays with the cable. The USB interface to the deskew IC and the software is needed to support the remote deskew control. The interface for the deskew IC is in its data sheet and in the HERMES-DEMO-BOARDZ' documentation.

Notice

1. Descriptions of circuits, software and other related information in this document are provided only to illustrate the operation of semiconductor products and application examples. You are fully responsible for the incorporation or any other use of the circuits, software, and information in the design of your product or system. Renesas Electronics disclaims any and all liability for any losses and damages incurred by you or third parties arising from the use of these circuits, software, or information.
2. Renesas Electronics hereby expressly disclaims any warranties against and liability for infringement or any other claims involving patents, copyrights, or other intellectual property rights of third parties, by or arising from the use of Renesas Electronics products or technical information described in this document, including but not limited to, the product data, drawings, charts, programs, algorithms, and application examples.
3. No license, express, implied or otherwise, is granted hereby under any patents, copyrights or other intellectual property rights of Renesas Electronics or others.
4. You shall not alter, modify, copy, or reverse engineer any Renesas Electronics product, whether in whole or in part. Renesas Electronics disclaims any and all liability for any losses or damages incurred by you or third parties arising from such alteration, modification, copying or reverse engineering.
5. Renesas Electronics products are classified according to the following two quality grades: "Standard" and "High Quality". The intended applications for each Renesas Electronics product depends on the product's quality grade, as indicated below.
"Standard": Computers; office equipment; communications equipment; test and measurement equipment; audio and visual equipment; home electronic appliances; machine tools; personal electronic equipment; industrial robots; etc.
"High Quality": Transportation equipment (automobiles, trains, ships, etc.); traffic control (traffic lights); large-scale communication equipment; key financial terminal systems; safety control equipment; etc.
Unless expressly designated as a high reliability product or a product for harsh environments in a Renesas Electronics data sheet or other Renesas Electronics document, Renesas Electronics products are not intended or authorized for use in products or systems that may pose a direct threat to human life or bodily injury (artificial life support devices or systems; surgical implantations; etc.), or may cause serious property damage (space system; undersea repeaters; nuclear power control systems; aircraft control systems; key plant systems; military equipment; etc.). Renesas Electronics disclaims any and all liability for any damages or losses incurred by you or any third parties arising from the use of any Renesas Electronics product that is inconsistent with any Renesas Electronics data sheet, user's manual or other Renesas Electronics document.
6. When using Renesas Electronics products, refer to the latest product information (data sheets, user's manuals, application notes, "General Notes for Handling and Using Semiconductor Devices" in the reliability handbook, etc.), and ensure that usage conditions are within the ranges specified by Renesas Electronics with respect to maximum ratings, operating power supply voltage range, heat dissipation characteristics, installation, etc. Renesas Electronics disclaims any and all liability for any malfunctions, failure or accident arising out of the use of Renesas Electronics products outside of such specified ranges.
7. Although Renesas Electronics endeavors to improve the quality and reliability of Renesas Electronics products, semiconductor products have specific characteristics, such as the occurrence of failure at a certain rate and malfunctions under certain use conditions. Unless designated as a high reliability product or a product for harsh environments in a Renesas Electronics data sheet or other Renesas Electronics document, Renesas Electronics products are not subject to radiation resistance design. You are responsible for implementing safety measures to guard against the possibility of bodily injury, injury or damage caused by fire, and/or danger to the public in the event of a failure or malfunction of Renesas Electronics products, such as safety design for hardware and software, including but not limited to redundancy, fire control and malfunction prevention, appropriate treatment for aging degradation or any other appropriate measures. Because the evaluation of microcomputer software alone is very difficult and impractical, you are responsible for evaluating the safety of the final products or systems manufactured by you.
8. Please contact a Renesas Electronics sales office for details as to environmental matters such as the environmental compatibility of each Renesas Electronics product. You are responsible for carefully and sufficiently investigating applicable laws and regulations that regulate the inclusion or use of controlled substances, including without limitation, the EU RoHS Directive, and using Renesas Electronics products in compliance with all these applicable laws and regulations. Renesas Electronics disclaims any and all liability for damages or losses occurring as a result of your noncompliance with applicable laws and regulations.
9. Renesas Electronics products and technologies shall not be used for or incorporated into any products or systems whose manufacture, use, or sale is prohibited under any applicable domestic or foreign laws or regulations. You shall comply with any applicable export control laws and regulations promulgated and administered by the governments of any countries asserting jurisdiction over the parties or transactions.
10. It is the responsibility of the buyer or distributor of Renesas Electronics products, or any other party who distributes, disposes of, or otherwise sells or transfers the product to a third party, to notify such third party in advance of the contents and conditions set forth in this document.
11. This document shall not be reprinted, reproduced or duplicated in any form, in whole or in part, without prior written consent of Renesas Electronics.
12. Please contact a Renesas Electronics sales office if you have any questions regarding the information contained in this document or Renesas Electronics products.
(Note 1) "Renesas Electronics" as used in this document means Renesas Electronics Corporation and also includes its directly or indirectly controlled subsidiaries.
(Note 2) "Renesas Electronics product(s)" means any product developed or manufactured by or for Renesas Electronics.

(Rev.4.0-1 November 2017)



SALES OFFICES

Renesas Electronics Corporation

<http://www.renesas.com>

Refer to "<http://www.renesas.com/>" for the latest and detailed information.

Renesas Electronics America Inc.
1001 Murphy Ranch Road, Milpitas, CA 95035, U.S.A.
Tel: +1-408-432-8888, Fax: +1-408-434-5351

Renesas Electronics Canada Limited
9251 Yonge Street, Suite 8309 Richmond Hill, Ontario Canada L4C 9T3
Tel: +1-905-237-2004

Renesas Electronics Europe Limited
Dukes Meadow, Millboard Road, Bourne End, Buckinghamshire, SL8 5FH, U.K
Tel: +44-1628-651-700, Fax: +44-1628-651-804

Renesas Electronics Europe GmbH
Arcadiastrasse 10, 40472 Düsseldorf, Germany
Tel: +49-211-6503-0, Fax: +49-211-6503-1327

Renesas Electronics (China) Co., Ltd.
Room 1709 Quantum Plaza, No.27 ZhichunLu, Haidian District, Beijing, 100191 P. R. China
Tel: +86-10-8235-1155, Fax: +86-10-8235-7679

Renesas Electronics (Shanghai) Co., Ltd.
Unit 301, Tower A, Central Towers, 555 Langao Road, Putuo District, Shanghai, 200333 P. R. China
Tel: +86-21-2226-0888, Fax: +86-21-2226-0999

Renesas Electronics Hong Kong Limited
Unit 1601-1611, 16/F., Tower 2, Grand Century Place, 193 Prince Edward Road West, Mongkok, Kowloon, Hong Kong
Tel: +852-2265-6688, Fax: +852-2886-9022

Renesas Electronics Taiwan Co., Ltd.
13F, No. 363, Fu Shing North Road, Taipei 10543, Taiwan
Tel: +886-2-8175-9600, Fax: +886-2-8175-9670

Renesas Electronics Singapore Pte. Ltd.
80 Bendemeer Road, Unit #06-02 Hyflux Innovation Centre, Singapore 339949
Tel: +65-6213-0200, Fax: +65-6213-0300

Renesas Electronics Malaysia Sdn.Bhd.
Unit 1207, Block B, Menara Amcorp, Amcorp Trade Centre, No. 18, Jln Persiaran Barat, 46050 Petaling Jaya, Selangor Darul Ehsan, Malaysia
Tel: +60-3-7955-9390, Fax: +60-3-7955-9510

Renesas Electronics India Pvt. Ltd.
No.777C, 100 Feet Road, HAL 2nd Stage, Indiranagar, Bangalore 560 038, India
Tel: +91-80-67208700, Fax: +91-80-67208777

Renesas Electronics Korea Co., Ltd.
17F, KAMCO Yangjae Tower, 262, Gangnam-daero, Gangnam-gu, Seoul, 06265 Korea
Tel: +82-2-558-3737, Fax: +82-2-558-5338