

Introduction

CAT-5 cable provides an enormous cost benefit over coax. The average cost of 100 meters of CAT-5 cable is \$20 while the average cost of 100 meters of Coax cable could easily exceed \$240. Furthermore, wiring is reduced from a bulky, hard-to-manage bundle of 3 cables to 1 easily-pulled cable. Additionally, CAT-5 cable has a 4th twisted pair available, which can be used for audio, timing or control signal transmission.

This paper provides in-depth information on component video standards and amplifier characteristics necessary to achieve those standards. The trade-offs of differential line driver and receiver topologies are discussed in detail. This paper also presents an array of common video problems along with an explanation of the source and a suggested solution. This array includes: ghosting, color matching, common-mode noise, power-supply noise, mismatches in channel timing and equalization.

With a focus on CAT-5, extra effort is spent in the discussion of video equalization techniques, an inevitable result of the lower bandwidth of the cables. While circuit specifics are presented, they involve manual tuning to compensate for the exact length of the cable used. Since manual tuning requires professional installation, two new systems based on automatic cable compensation are also presented.

Video Example - SXGA

We have chosen to discuss the main aspects of a video system with respect to the SXGA video standard. Table 1 presents key parameters of 76Hz SXGA video signal so we can calculate the bandwidth and slew rate needed in the driver and receiver amplifiers. If not provided, the signal bandwidth is calculated with the Equation 1:

$$BWS = (1/2)(K \cdot AR \cdot (VLT)^2 \cdot FR) \cdot (KH)/(KV) = 51.9\text{MHz} \quad (\text{EQ. 1})$$

where BWS = Signal bandwidth

K = Kell factor, Visual information is lost when video information passes during the retrace rather than the active portion of the scan line. Assuming 30% of the visual information is lost, K = 0.7.

AR = Aspect ratio (the display width divided by display height) = 1.33

VLT = Total number of vertical pixels = 1067

FR = Frame rate or refresh rate = 76

KH = Ratio of total horizontal pixels to active pixels = 1720/1280 = 1.34

KV = Ratio of total vertical lines to active lines = 1.04

TABLE 1. PARAMETERS OF SXGA VIDEO STANDARD

PARAMETER	VALUE
Active Horizontal Pixels	1280
Active Vertical Pixels	1311
Total Horizontal Pixels	1720
Total Vertical Pixels (VLT)	1067
Frame Rate (FR)	76Hz
Horizontal Rate	81.1kHz
Pixel Rate	139.5Mpixels/second
Signal Bandwidth (BWS)	51.9MHz

The signal bandwidth is calculated to ensure adequate system bandwidth. When choosing an amplifier, remember that the reported bandwidth is measured as the half-power point, also known as the 3dB frequency. The 50% loss of power at this frequency is not acceptable in any part of the video signal bandwidth. Therefore, it is customary to determine the 0.1dB bandwidth of the amplifiers chosen for the drivers and receivers of the video system. The correlation between 3dB bandwidth and 0.1dB bandwidth will depend on the number of poles in the amplifier. A single-pole amplifier needs to have a reported 3dB bandwidth of 337MHz (~6.5 times more than 51.9MHz) to have sufficient 0.1dB bandwidth. A multiple-pole amplifier (including most modern high-speed amplifiers) must have a 3dB bandwidth of at least 156MHz (~3 times more than 51.9MHz) to ensure the proper 0.1dB bandwidth.

The second crucial characteristic is slew rate. The slew-rate can be calculated from the signal amplitude and pixel rate. To maintain video signal integrity for a pixel rate of 139.5MHz and a swing of ~1V transition during ¼ of a clock period:

$$\text{Slew Rate} = 1/(1/4 \cdot \text{Pixel Time}) = 1/(1/4 \cdot (1/139.5\text{MHz})) = 558\text{V}/\mu\text{s} \quad (\text{EQ. 2})$$

Therefore, the video driver and receiver must have bandwidth in excess of 337MHz (worst case) and slew rate greater than 558V/μs.

CAT-5 Cable Characteristics

Standard CAT-5 cable consists of 4 twisted pairs of AWG 24 cable, which has a characteristic impedance of 100Ω. The DC resistance is 10Ω/100m with a capacitance of 4.6nF/100m. One important characteristic of SXGA video transmission is high frequency cable attenuation, which increases exponentially over frequency and distance. Figure 1 shows the effects of signal frequency and cable length on the signal attenuation. As Figure 1 illustrates, the losses within CAT-5 cable are significant at 51.9MHz, the calculated signal bandwidth of SXGA.

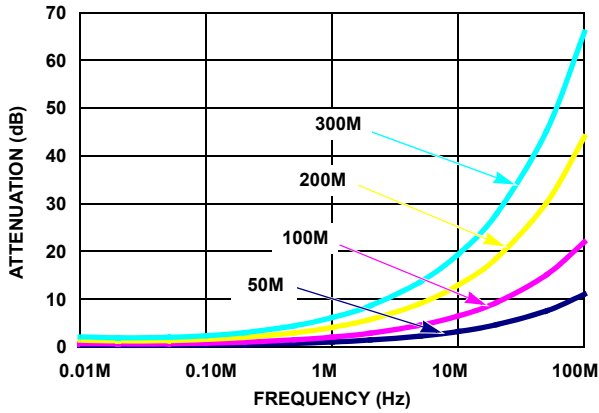

FIGURE 1. CAT-5 CABLE ATTENUATION CHARACTERISTICS

Differential Line Driver Topologies

Figure 2 illustrates a standard differential input and output line driver system built with discrete operational amplifiers. The differential output driver doubles the output voltage swing – while the resistors R_F and R_G determine the circuit voltage gain with Equation 3:

$$V_{OUT}/V_{IN} = 1 + 2 \cdot R_F/R_G \quad (\text{EQ. 3})$$

High noise rejection such as 60Hz power line interference is accomplished by amplifying only the differential input voltage signals and not amplifying the common-mode input voltage. The only real disadvantage of this circuit is the required differential input signal sources.

Typically, signals originate in single-ended rather than differential form. Converting single-ended signals to differential mode prior to line transmission reaps the benefit of high common-mode noise reduction. The circuit in Figure 3 provides a very simple way to generate a differential output signal from a single-ended input signal using two operational amplifiers; the upper amplifier is non-inverting while the bottom is inverting.

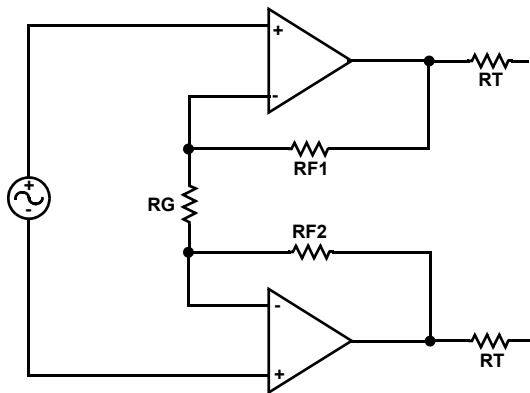

FIGURE 2. DIFFERENTIAL LINE DRIVER WITH DISCRETE AMPLIFIERS

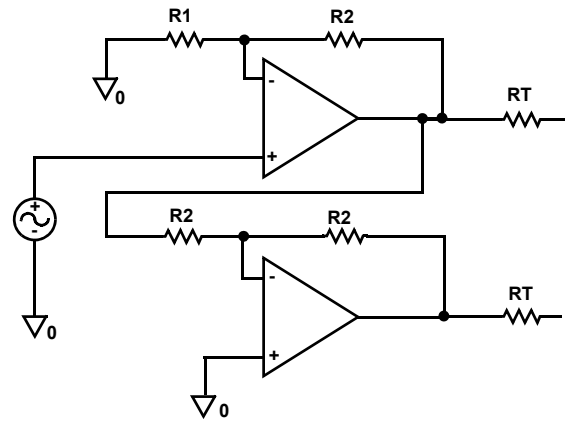

FIGURE 3. SINGLE-ENDED TO DIFFERENTIAL LINE DRIVER

Note the amplifiers in Figure 3 have different feedback ratios (closed-loop gain) which results in different bandwidths for voltage feedback amplifiers. The difference in bandwidth causes higher frequency signal mismatch and can lead to distortion. An integrated solution will ensure proper matching and the EL5177 is available. It is a differential output amplifier with a bandwidth of 550MHz, a slew rate of 1100V/ μ s, and can accept single or differential inputs. This device is internally compensated for a stable closed-loop gain of +1 and the gain is set by an external R_F and R_G while the common mode output voltage is controlled by a reference pin.

Differential Line Receiver Topologies

Figure 4 shows a differential to single-ended converter implemented with high-speed amplifiers. The advantage is both a very high input impedance and very high common mode rejection achieved with simplicity. Bandwidth mismatch of the two amplifiers introduces the possibility of high-frequency distortion. The differential gain is determined by R_1 and R_2 resistors with the relationship:

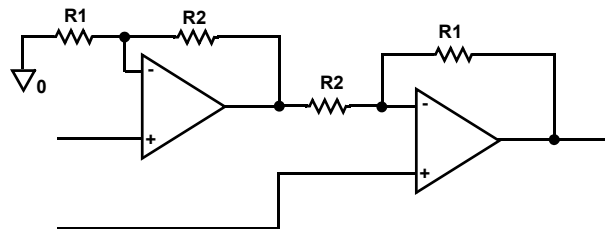

FIGURE 4. DIFFERENTIAL TO SINGLE-ENDED CONVERTER, GAIN = $1 + R_1/R_2$

An integrated, balanced receiver solution, the EL5175, provides the complement to the integrated driver, the EL5177. It takes the differential signal from the CAT-5 cable and provides a single-ended output within a 550MHz bandwidth and 622V/ μ s slew rate.

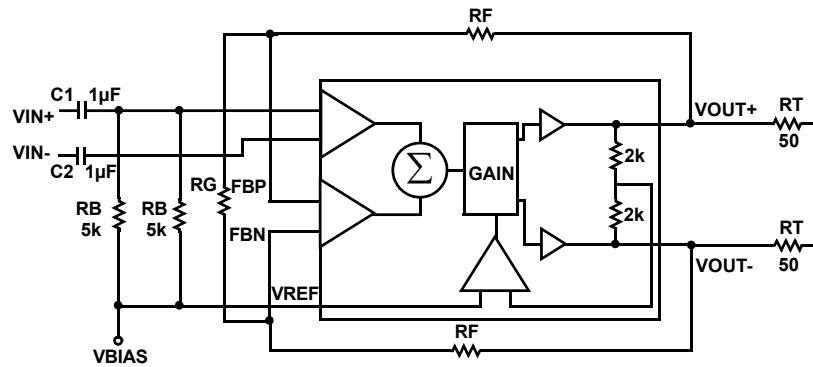

FIGURE 5. CAT-5 CABLE TERMINATION SCHEME (DRIVER SIDE)

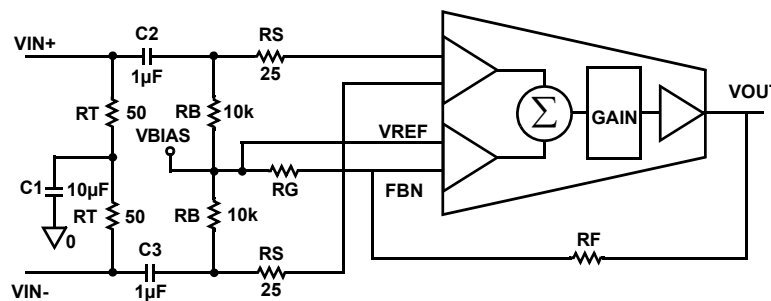

FIGURE 6. CAT-5 CABLE TERMINATION SCHEME (RECEIVER SIDE)

Common Video Problems and Solutions

Video systems can experience a myriad of problems. Many of those problems are uncovered and explained in the following paragraphs. Solutions are presented as space allows. The issue of equalization, brought about by the attenuation inherent in CAT-5 cable, is discussed in detail.

Video Problem 1: Ghosting

Ghosting occurs when a circuit does not have proper termination. Improper termination causes ringing, which appears as additional images after the original image. It always occurs horizontally and to the observer's right—following the path of the video signal.

To avoid reflections and maintain integrity of the input video signals, each stage must be properly terminated. The characteristic impedance of a standard CAT-5 cable is 100Ω which is split into two 50Ω resistors for driving the line differentially. Figures 5 and 6 show the termination schemes on the driver and receiver sides.

C₁ and R_T of the receiver form a low pass filter to reject high frequency common-mode noise on the cable. Capacitors isolate DC voltage differences in the ground potential of the driver and receiver systems. A small resistor R_s isolates the

input capacitance of the receiver from the PCB trace inductance to avoid any resonance at the amplifier inputs.

Some video systems do not have a negative supply available and require single supply operation. The above circuits also show the implementation of single supply operation.

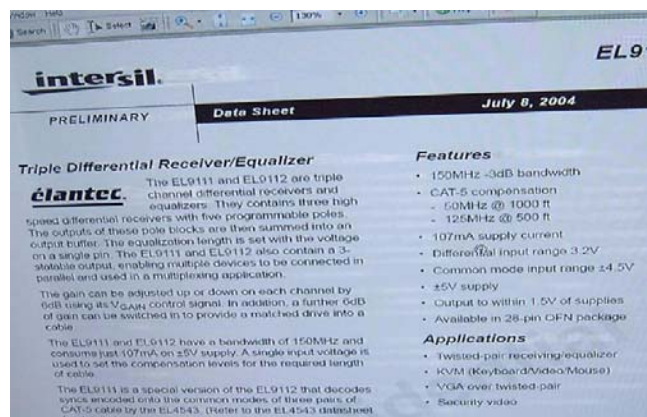

FIGURE 7. EXAMPLE OF WHITE GHOSTING ON A WEB PAGE

Video Problem 2: Color Mismatch

Color mismatch is the effect of a difference in gain or offset of the R, G, and B channels. This offset can be adjusted manually with resistive dividers or additional op amps. An integrated solution is available in the EL9111.

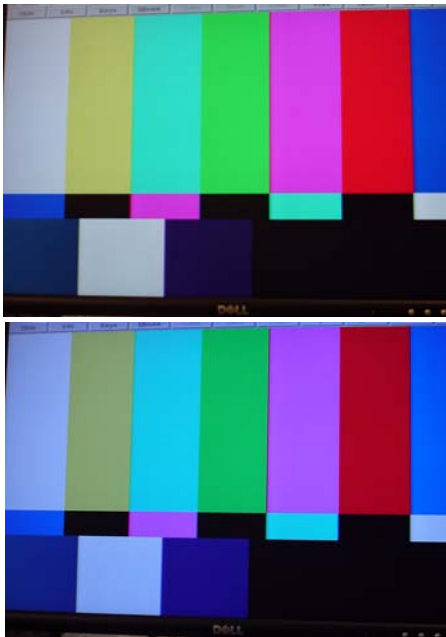

FIGURE 8. EXAMPLES OF COLOR MISMATCH. THE SCREEN ON THE BOTTOM HAS EXCESS BLUE

Video Problem 3: Common-mode Noise

Since the horizontal and vertical sync information is typically transmitted as a common-mode signal, common-mode noise can cause a loss of synchronization. An example of delay in horizontal sync is shown in Figure 9. Figure 12 shows a circuit to eliminate it. The sum of all of the common-mode signals is gathered at the amplifier at the bottom and fed back as a reference to each of the signal line.

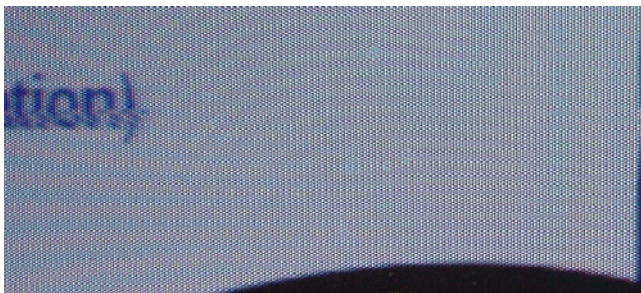

FIGURE 9. EXAMPLE OF LOSS OF HORIZONTAL SYNCHRONIZATION

Video Problem 4: Power Supply Noise

Power supply noise appears as a repetitious disturbance in the video picture. As the power supply is effectively raised and lowered, the gains of the amplifiers are altered. This commonly causes the striping that appears in the following figures. To avoid this unwanted behavior, use a higher quality voltage regulator to power the amplifiers and bypass all ICs as close to the power pins as possible.

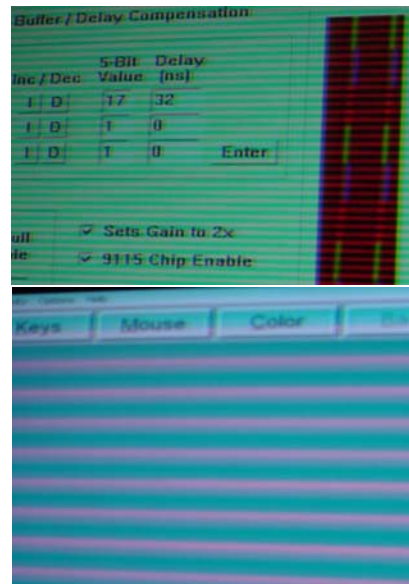

FIGURE 10. EXAMPLES OF POWER SUPPLY NOISE

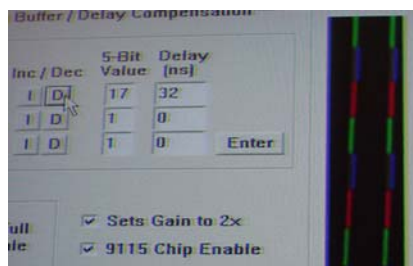

FIGURE 11. EXAMPLES OF CHANNEL TIMING MISMATCH

Video Problem 5: Channel Timing Mismatch

If the R, G, and B signals are mismatched with respect to time, they will cause a blurring of the signal. In Figure 11, the left side shows each of the color signals and blue is late with respect to the others. This causes an offset in the overlay of the three colors. In Figure 11, look at the icons on the right where the blue has been overcompensated and is appearing first, causing the other colors to appear as a trailing edge.

This usually signifies a mismatch in line length, either within the cable or the printed circuit board. An analog delay line can be added to delay early signals, but must be tuned for the given circuit. An integrated solution is available, the EL9115, which will insert a specific delay into any or all of the three video signals. In fact, we used it to offset the blue signal and create these images.

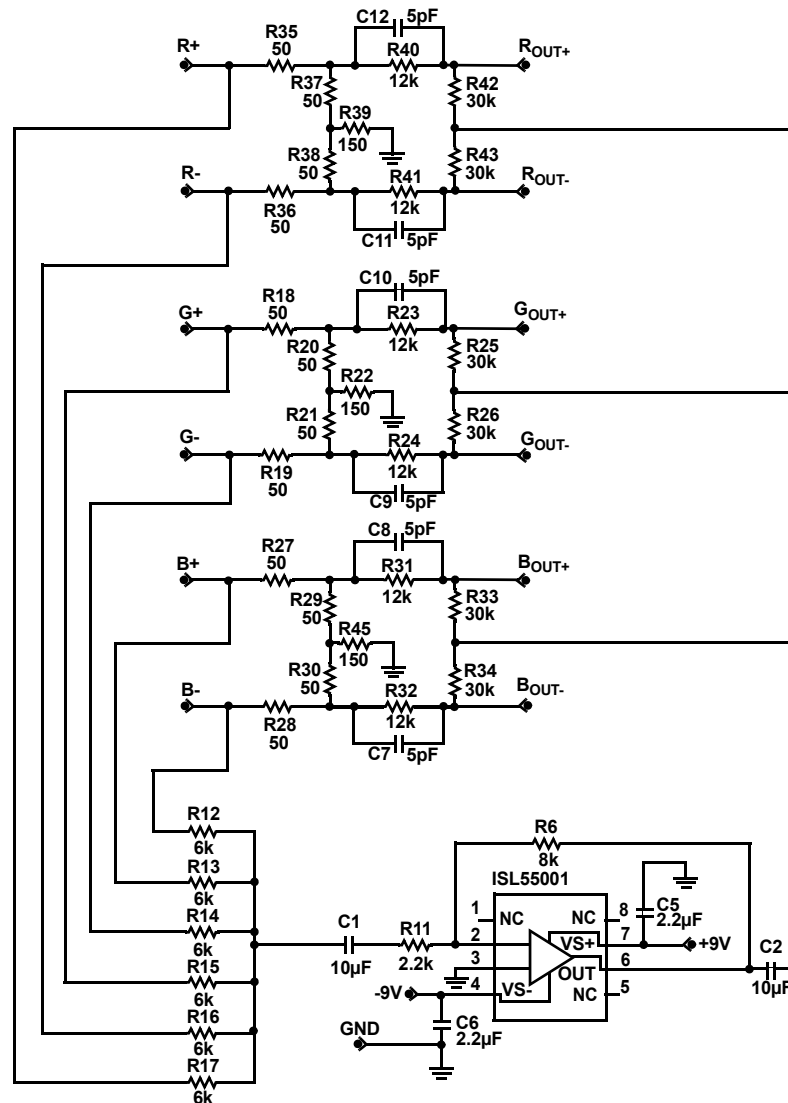

FIGURE 12. COMMON-MODE FEEDBACK CIRCUIT TO CORRECT SYNCHRONIZATION PROBLEMS

Video Problem 6: Equalization

Equalization issues are unavoidable when using CAT-5 cable. Since the cable attenuates some of the signal bandwidth, the high frequency signals will be distorted. This causes the smearing apparent in Figure 13. Compensation is needed to rectify the high frequency losses of the system. This compensation can be provided at the driver (before entering the cable, predistortion) or at the receiver (after going through the cable).



FIGURE 13. VIDEO SIGNAL WITH SMEARING (TOP) AND WITHOUT SMEARING (BOTTOM)

**VIDEO EQUALIZATION STRATEGIES:
PRE-EQUALIZATION VERSUS POST-EQUALIZATION**

Figure 14 shows a very simple method of pre-equalizing the line with the inclusion of a parallel 1.6nF capacitor with the termination resistor. The 1.6nF capacitor shorts the 50Ω termination resistor at high frequencies and allows a larger amount of signal on the line. The resistor-capacitor combination is a single pole high pass filter with a zero at 2MHz. The maximum achievable gain at high frequency is limited to 6dB. In this scheme, cable parasitic capacitance appears at the amplifier output and can lead to oscillation.

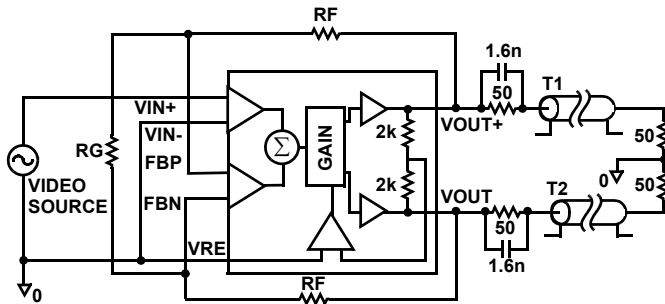

FIGURE 14. SINGLE-POLE PRE-EQUALIZATION SCHEME

Figure 15 shows a 3 pole compensation circuit using a 1GHz bandwidth high slew rate amplifier. The circuit is configured around the gain setting resistor that places the poles at 1.2MHz, 15MHz and 100MHz respectively. The amount of high frequency compensation is determined by the resistance. The capacitor and resistor combinations set the pole frequencies. Theoretically, this circuit can be used for both pre and post equalization. In practice the line driver slew rate and output swing limit the pre-equalization performance; for instance, a 1V 60MHz input signal becomes a 12.6V 60MHz signal at the line driver output requiring approximately a 5kV/μS slew rate. This would require a factor of 10 increase in slew rate. Therefore, this circuit should always be implemented in a post-equalization configuration where the incoming high frequency signal is low in amplitude.

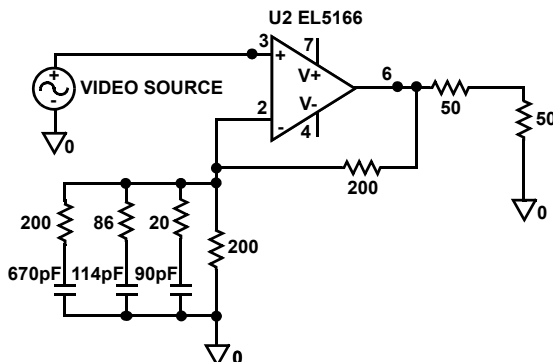

FIGURE 15. 3 POLE POST-EQUALIZATION SCHEME

A third solution is the EL9110, a differential line receiver with an integrated CAT-5 cable compensation network. Since the frequency-dependent losses are preprogrammed into the amplifier, a control voltage allows the amplifier to compensate for the cable loss.

Figure 16 shows a comparison of 100 meter CAT-5 cable attenuation and the frequency responses of the 3 cable compensation circuits. The 1.6pF//R_{OUT} compensation circuit works well up to 10MHz. The frequency response of the 3 pole compensation circuit comes very close to matching the CAT-5 cable attenuation. The EL9110, with V_{GAIN} set to 0.24V, compensates for signal frequencies up to 100MHz.

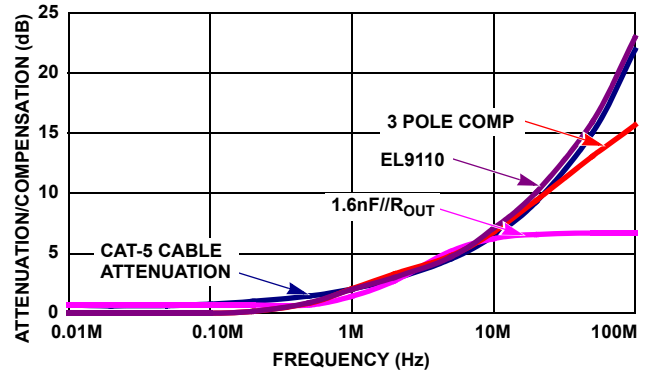

FIGURE 16. 100m CAT-5 CABLE ATTENUATION AND COMPENSATION

Automated Equalization - Step-Response Solution

With the acquisition of an IC internally programmed with the frequency-dependent losses of CAT-5 cable, an automated system can be constructed to provide the gain voltage. We offer two methods for determining this gain input and therefore the amount of compensation necessary to offset cable losses. The first is a digital solution using the non ideality of a step response.

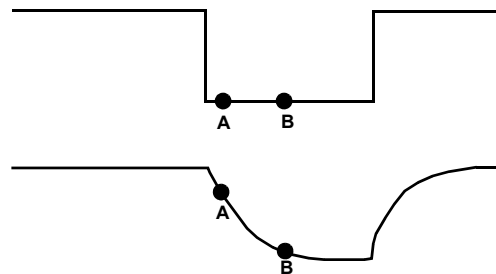

FIGURE 17. COMPENSATED (ABOVE) AND UNCOMPENSATED (BELOW) SYNC TIPS

In a properly compensated receiver; the edges are square. In a grossly under compensated receiver, the edges are soft and indistinct due to the cable's attenuation of the high frequency components. The rest of the video signal suffers equally, but the sync tip shows the effect of under compensation most dramatically.

Consider the points labeled "A" and "B" in Figure 17. In a properly-compensated receiver, the sync tip is flat, and the slope between points A and B is roughly zero. Without compensation, the sync tip is not flat and there is a negative slope between points A and B. The slope of the line between these two points can be used to measure the compensation

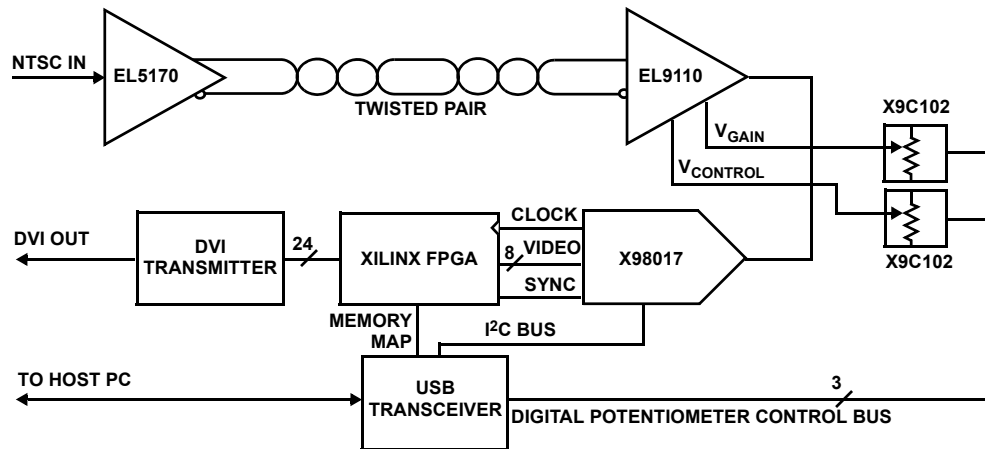

FIGURE 18. AUTOMATIC EQUALIZATION LOOP BLOCK DIAGRAM

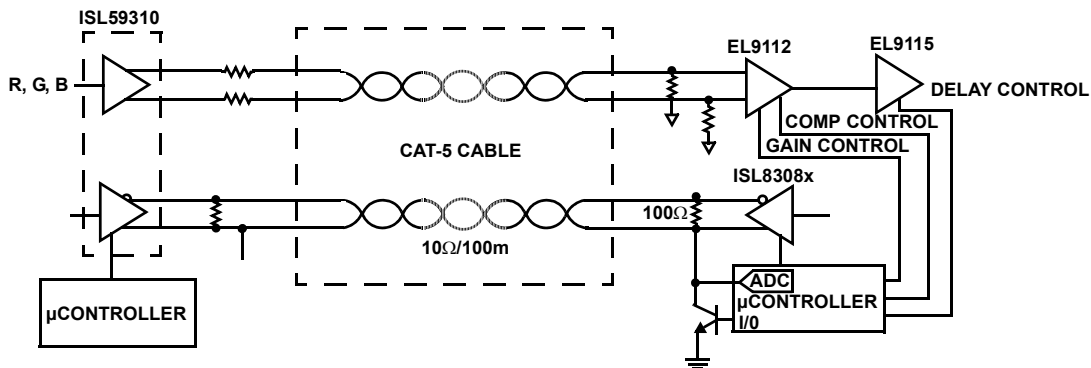

FIGURE 19. AUTOMATIC EQUALIZATION CIRCUIT USING RESISTANCE MEASUREMENT OF LINE

quality and provides a means to develop an auto-equalization loop.

The analog transmission line is comprised of an EL5170 twisted-pair transmitter, CAT-5 cable, and EL9110 single channel receiver and equalizer. The EL9110's gain and equalization settings (V_{GAIN} and $V_{CONTROL}$) are controlled digitally with two X9C102 digitally-controlled potentiometers.

Automated Equalization – Resistive Method

In the method shown in Figure 19, the fourth pair of wires is used to calculate the loss of the CAT-5 cable. Since the loss of CAT-5 cable is 10Ω per 100 meters and the total loss incurred typically remains less than 100Ω , a resistive divider is formed to calculate the length. Figure 20 demonstrates the resistor-divider set-up on the fourth pair of wires. This fourth pair is driven on both ends. The driver also has the ability to disconnect from the line when set for high impedance.

After the driver (left side) is set to provide a constant 5V, the ISL8308x has its output set for high impedance. With a transistor acting as a switch, the resistive divider shown in Figure 20 is created. The voltage read by the microcontroller will reveal the line loss using Equation 4:

$$V_{MEASURED} = 5V \cdot [R_{LINE} / (2 \cdot R_{LINE} + 100\Omega)] \quad (EQ. 4)$$

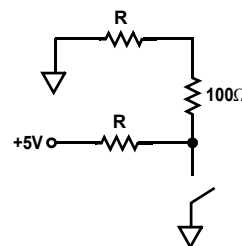

FIGURE 20. RESISTIVE DIVIDER FORMED ON 4TH PAIR OF CAT-5 WIRES FOR MEASURING LENGTH

A microcontroller is configured to read this voltage and send the appropriately scaled voltage to the gain input of the ISL9112 line receiver. Since the ISL9112 includes specialized compensation for CAT5 cable loss, the calibration is complete and the system is operational.

Conclusion

CAT-5 cable provides a low-cost option for transmitting video signals. Many potential problems are discussed along with suggestions and solutions. Emphasis on equalization, including two complete automated systems, gives multiple options for compensating high frequency losses.

Author Biography:

Tamara Papalias is a principle applications engineer with nine years of consulting experience within Intersil's applications group. She is also a full-time professor of electrical engineering focusing on analog circuits and test development at San Jose State University. She has her BSEE, MSEE, and PhD in RF CMOS design from Stanford University.

Mike Wong is the director of application engineering for Intersil's Elantec Product group where he has worked for over 10 years. He specializes in high performance analog circuit and power management applications. He has previously worked at ASTEC. He has a BSEE from University of California at Davis.

Notice

1. Descriptions of circuits, software and other related information in this document are provided only to illustrate the operation of semiconductor products and application examples. You are fully responsible for the incorporation or any other use of the circuits, software, and information in the design of your product or system. Renesas Electronics disclaims any and all liability for any losses and damages incurred by you or third parties arising from the use of these circuits, software, or information.
2. Renesas Electronics hereby expressly disclaims any warranties against and liability for infringement or any other claims involving patents, copyrights, or other intellectual property rights of third parties, by or arising from the use of Renesas Electronics products or technical information described in this document, including but not limited to, the product data, drawings, charts, programs, algorithms, and application examples.
3. No license, express, implied or otherwise, is granted hereby under any patents, copyrights or other intellectual property rights of Renesas Electronics or others.
4. You shall not alter, modify, copy, or reverse engineer any Renesas Electronics product, whether in whole or in part. Renesas Electronics disclaims any and all liability for any losses or damages incurred by you or third parties arising from such alteration, modification, copying or reverse engineering.
5. Renesas Electronics products are classified according to the following two quality grades: "Standard" and "High Quality". The intended applications for each Renesas Electronics product depends on the product's quality grade, as indicated below.
"Standard": Computers; office equipment; communications equipment; test and measurement equipment; audio and visual equipment; home electronic appliances; machine tools; personal electronic equipment; industrial robots; etc.
"High Quality": Transportation equipment (automobiles, trains, ships, etc.); traffic control (traffic lights); large-scale communication equipment; key financial terminal systems; safety control equipment; etc.
Unless expressly designated as a high reliability product or a product for harsh environments in a Renesas Electronics data sheet or other Renesas Electronics document, Renesas Electronics products are not intended or authorized for use in products or systems that may pose a direct threat to human life or bodily injury (artificial life support devices or systems; surgical implantations; etc.), or may cause serious property damage (space system; undersea repeaters; nuclear power control systems; aircraft control systems; key plant systems; military equipment; etc.). Renesas Electronics disclaims any and all liability for any damages or losses incurred by you or any third parties arising from the use of any Renesas Electronics product that is inconsistent with any Renesas Electronics data sheet, user's manual or other Renesas Electronics document.
6. When using Renesas Electronics products, refer to the latest product information (data sheets, user's manuals, application notes, "General Notes for Handling and Using Semiconductor Devices" in the reliability handbook, etc.), and ensure that usage conditions are within the ranges specified by Renesas Electronics with respect to maximum ratings, operating power supply voltage range, heat dissipation characteristics, installation, etc. Renesas Electronics disclaims any and all liability for any malfunctions, failure or accident arising out of the use of Renesas Electronics products outside of such specified ranges.
7. Although Renesas Electronics endeavors to improve the quality and reliability of Renesas Electronics products, semiconductor products have specific characteristics, such as the occurrence of failure at a certain rate and malfunctions under certain use conditions. Unless designated as a high reliability product or a product for harsh environments in a Renesas Electronics data sheet or other Renesas Electronics document, Renesas Electronics products are not subject to radiation resistance design. You are responsible for implementing safety measures to guard against the possibility of bodily injury, injury or damage caused by fire, and/or danger to the public in the event of a failure or malfunction of Renesas Electronics products, such as safety design for hardware and software, including but not limited to redundancy, fire control and malfunction prevention, appropriate treatment for aging degradation or any other appropriate measures. Because the evaluation of microcomputer software alone is very difficult and impractical, you are responsible for evaluating the safety of the final products or systems manufactured by you.
8. Please contact a Renesas Electronics sales office for details as to environmental matters such as the environmental compatibility of each Renesas Electronics product. You are responsible for carefully and sufficiently investigating applicable laws and regulations that regulate the inclusion or use of controlled substances, including without limitation, the EU RoHS Directive, and using Renesas Electronics products in compliance with all these applicable laws and regulations. Renesas Electronics disclaims any and all liability for damages or losses occurring as a result of your noncompliance with applicable laws and regulations.
9. Renesas Electronics products and technologies shall not be used for or incorporated into any products or systems whose manufacture, use, or sale is prohibited under any applicable domestic or foreign laws or regulations. You shall comply with any applicable export control laws and regulations promulgated and administered by the governments of any countries asserting jurisdiction over the parties or transactions.
10. It is the responsibility of the buyer or distributor of Renesas Electronics products, or any other party who distributes, disposes of, or otherwise sells or transfers the product to a third party, to notify such third party in advance of the contents and conditions set forth in this document.
11. This document shall not be reprinted, reproduced or duplicated in any form, in whole or in part, without prior written consent of Renesas Electronics.
12. Please contact a Renesas Electronics sales office if you have any questions regarding the information contained in this document or Renesas Electronics products.
(Note 1) "Renesas Electronics" as used in this document means Renesas Electronics Corporation and also includes its directly or indirectly controlled subsidiaries.
(Note 2) "Renesas Electronics product(s)" means any product developed or manufactured by or for Renesas Electronics.

(Rev.4.0-1 November 2017)



SALES OFFICES

Renesas Electronics Corporation

<http://www.renesas.com>

Refer to "<http://www.renesas.com/>" for the latest and detailed information.

Renesas Electronics America Inc.
1001 Murphy Ranch Road, Milpitas, CA 95035, U.S.A.
Tel: +1-408-432-8888, Fax: +1-408-434-5351

Renesas Electronics Canada Limited
9251 Yonge Street, Suite 8309 Richmond Hill, Ontario Canada L4C 9T3
Tel: +1-905-237-2004

Renesas Electronics Europe Limited
Dukes Meadow, Millboard Road, Bourne End, Buckinghamshire, SL8 5FH, U.K
Tel: +44-1628-651-700, Fax: +44-1628-651-804

Renesas Electronics Europe GmbH
Arcadiastrasse 10, 40472 Düsseldorf, Germany
Tel: +49-211-6503-0, Fax: +49-211-6503-1327

Renesas Electronics (China) Co., Ltd.
Room 1709 Quantum Plaza, No.27 ZhichunLu, Haidian District, Beijing, 100191 P. R. China
Tel: +86-10-8235-1155, Fax: +86-10-8235-7679

Renesas Electronics (Shanghai) Co., Ltd.
Unit 301, Tower A, Central Towers, 555 Langao Road, Putuo District, Shanghai, 200333 P. R. China
Tel: +86-21-2226-0888, Fax: +86-21-2226-0999

Renesas Electronics Hong Kong Limited
Unit 1601-1611, 16/F., Tower 2, Grand Century Place, 193 Prince Edward Road West, Mongkok, Kowloon, Hong Kong
Tel: +852-2265-6688, Fax: +852-2886-9022

Renesas Electronics Taiwan Co., Ltd.
13F, No. 363, Fu Shing North Road, Taipei 10543, Taiwan
Tel: +886-2-8175-9600, Fax: +886-2-8175-9670

Renesas Electronics Singapore Pte. Ltd.
80 Bendemeer Road, Unit #06-02 Hyflux Innovation Centre, Singapore 339949
Tel: +65-6213-0200, Fax: +65-6213-0300

Renesas Electronics Malaysia Sdn.Bhd.
Unit 1207, Block B, Menara Amcorp, Amcorp Trade Centre, No. 18, Jln Persiaran Barat, 46050 Petaling Jaya, Selangor Darul Ehsan, Malaysia
Tel: +60-3-7955-9390, Fax: +60-3-7955-9510

Renesas Electronics India Pvt. Ltd.
No.777C, 100 Feet Road, HAL 2nd Stage, Indiranagar, Bangalore 560 038, India
Tel: +91-80-67208700, Fax: +91-80-67208777

Renesas Electronics Korea Co., Ltd.
17F, KAMCO Yangjae Tower, 262, Gangnam-daero, Gangnam-gu, Seoul, 06265 Korea
Tel: +82-2-558-3737, Fax: +82-2-558-5338