

A Primer on Digitally-Controlled Potentiometers

AN124
Rev.0.00
June 7, 2005

The objective of this technical note is to provide the design engineer with the fundamentals of the operation and application of digitally-controlled potentiometers.

The potentiometer is a three terminal variable, resistance-like device whose schematic symbol is shown in Figure 1.

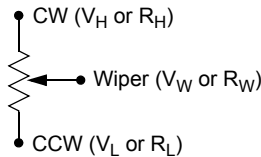

FIGURE 1. SCHEMATIC SYMBOL OF THE POTENTIOMETER

There are two types of potentiometers; mechanical and electronic. The terminals of the mechanical potentiometer are called CW (clockwise), CCW (counter clockwise), and wiper. The corresponding names or designations for the terminals of the electronic version are V_H or R_H , V_L or R_L , and the wiper V_W or R_W . The mechanical pot is a three terminal device while the electronic pot is an integrated circuit with a minimum of eight terminals.

Intersil's digitally-controlled potentiometer (XDCP) is an electronic potentiometer whose wiper position is computer or digitally controlled. The electronic version of the potentiometer also has memory where wiper settings and/or data can be stored.

The digitally-controlled potentiometer (XDCP) is a system level control device performing a component level function.

The block diagram of a typical digitally-controlled potentiometer is shown in Figure 2.

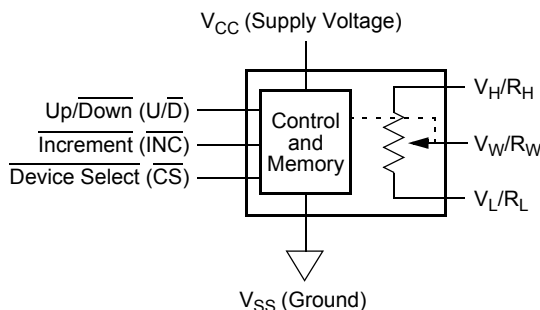

FIGURE 2. BLOCK DIAGRAM OF THE DIGITALLY-CONTROLLED POTENTIOMETER

The control and memory section of the device is implemented in CMOS and biased with a 3V or 5V digital or logic supply. The device is controlled through one of three different serial buses; (1) 3-wire, (2) 2-wire similar to I²C, and (3) SPI (Serial Peripheral Interface). The control signals

for the 3-wire bus are Up/Down, Increment, and Device Select. The Up/Down control input is a level sensitive signal which establishes the direction of the movement of the wiper. The wiper is moved on the falling edge of the Increment control input in the direction established by the Up/Down signal. The Device Select control input is like an address line and enables or disables the device. The control inputs for the 2-wire bus are Clock (SCL), a bidirectional Serial Data line (SDA), and Address lines (ADDR). The control inputs for the SPI bus are Clock (SCK), Serial In (SI) and Serial Out (SO) data lines, and address lines (ADDR). The 2-wire and SPI serial interfaces have protocols that are explained in the data sheets.

The digitally-controlled potentiometer is an integrated circuit whose implementation is shown in Figure 3. Polycrystalline resistors are connected in series between the R_H and R_L terminals and solid state switches implemented by nMOS or CMOS transistors are connected at each end of this resistor array and between the resistors. The switches are equivalent to a single pole, single throw switch. One end of all the switches are tied together and are connected to the wiper terminal. Only one switch will be closed at a time connecting a node in the series resistor array to the wiper. The resistors are polycrystalline silicon deposited on a oxide layer to insulate them from the other circuitry.

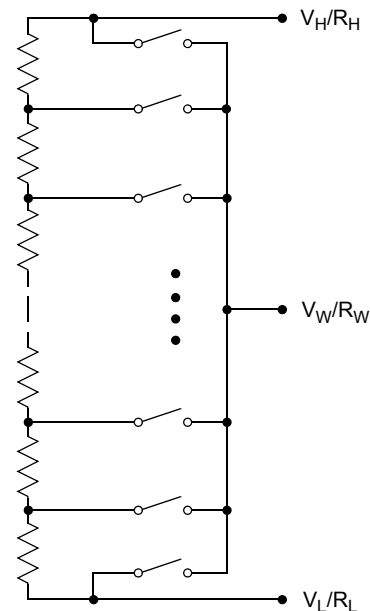

FIGURE 3. IMPLEMENTATION OF THE ELECTRONIC POTENTIOMETER

The potentiometer can be used in application circuits as a three terminal device or as a two terminal device. The most common way to use the potentiometer as a three terminal

device, Figure 4, is as a voltage divider circuit. Plus and/or minus voltages are connected across the *potentiometer* and the wiper goes from one voltage limit to the other as the wiper is moved from the low to high terminals. In many applications, this circuit can be substituted for a digital-to-analog converter since it performs a digital in, analog out function.

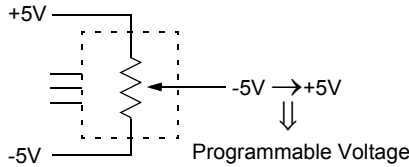

FIGURE 4. THREE TERMINAL CONFIGURATION AND APPLICATION

The second fundamental way of using the XDCP is as a two terminal, *variable resistance*. A simple application illustrating this configuration is shown in Figure 5 where the potentiometer functions as a variable resistor and, in essence, varies the current through the LED since the voltage across the potentiometer is relatively constant.

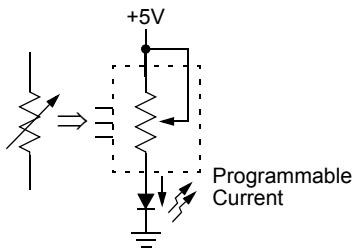

FIGURE 5. TWO TERMINAL CONFIGURATION AND APPLICATION

The two basic applications illustrate the use of the digitally controlled potentiometer in a digital-to-analog voltage circuit and in a digital-to-analog current circuit.

Figure 6 expands the block diagram of the XDCP to include the internal registers and data paths. The WCR or Wiper Counter Register is a volatile register whose output determines the position of the wiper by closing a switch connecting the wiper terminal to a point in the resistor array. For the XDCPs with a 2-wire or SPI bus, there are also four nonvolatile Data Registers (R_{0-3}) which can be used to store data or additional wiper settings. The wiper counter and data registers can be programmed from the bus or data can be transferred between the registers through the device's instruction set. Normally, data register R_0 is used to store the wiper setting for the power-up condition. For the XDCPs with a 3-wire interface, there is only one internal nonvolatile register per potentiometer, which stores the wiper setting for restoration during the power-up condition.

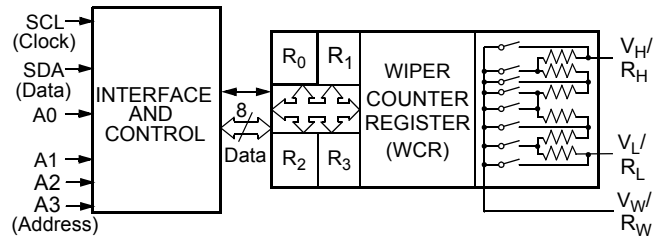

FIGURE 6. XDCP SYSTEM CONTROL AND REGISTERS

The XDCPs with a 2-wire (I^2C) or SPI serial bus have an instruction set. The typical instructions are shown in Figure 7 along with the typical bit structure in Figure 8. The instructions control the flow of data internally or through the bus, the increment/decrement feature, and some specialized commands. The global transfer command transfers data between registers in devices with a multiple number of potentiometers and the write in progress (WIP) instruction monitors the completion of the nonvolatile write process.

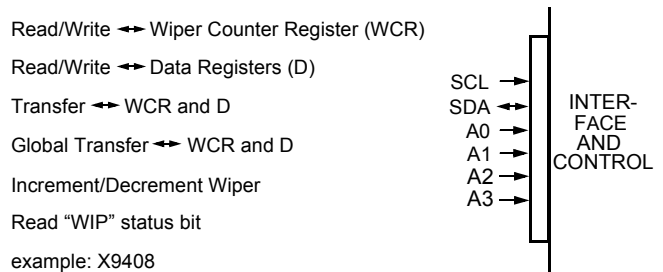

FIGURE 7. INSTRUCTION SET

Intersil digitally-controlled potentiometers also come with active devices like operational amplifiers and comparators. The block diagram of the dual pot-dual op amp device is shown in Figure 9.

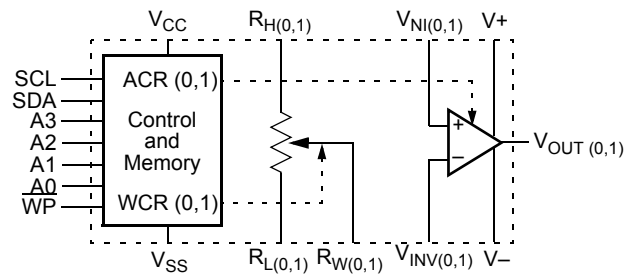

FIGURE 8. POTENTIOMETER AND OPERATIONAL AMPLIFIER

The terminals of both the potentiometer and the op amp are brought out to accommodate all possible configurations. The op amp is powered or biased with the externally connected V_+ and V_- analog voltage supplies. The WCR programs the location of the wiper of the potentiometer and the Analog Control Register (ACR) programs features of the operational amplifier.

The analog data sheet parameters reflect the limitations of the digitally-controlled potentiometer. The key analog data sheet parameters are number of taps, end to end resistance, maximum voltages on the potentiometer pins, wiper resistance and current, power rating, resolution, noise, linearity, and temperature coefficient. Figure 10 lists the data sheet parameters and their values for a typical XDCP.

The number of taps in a potentiometer varies from 16 to 256 and reflects the resolution of the device or its ability to discern 1 of n. The end to end resistance (R_H to R_L) of the potentiometer is R_{TOTAL} and comes in $1k^{3/4}$ to $1M^{3/4}$ values. The voltage V_{CC} , 3 to 5V, provides the voltage biasing for the digital control and memory section and $V+$ and $V-$ provide the voltage biasing for the analog section. The voltages $V_{TERMINAL}$ are the maximum voltages, $\pm 5V$ to $+15V$, that can be applied to the potentiometer pins in their application. Wiper resistance, nominally 40W, models the resistance r_{ds} (on) of the MOS switches used to connect the wiper terminal to a node in the resistor array. The wiper current spec, 1-3mA, limits the

maximum amount of current allowed through the wiper switches. Absolute linearity describes the actual versus expected value of the potentiometer when used as a divider and is guaranteed to be accurate within one least significant bit or minimum increment (MI). Relative linearity describes the tap to tap accuracy and is guaranteed to be 0.2 of an LSB or MI. The potentiometer has a maximum power rating between 10mW and 50mW. Two parameters describe the temperature dependence of R_{TOTAL} and the resistances in the series array. R_{TOTAL} TC (temperature coefficient) is a nominal 300ppm/ $^{\circ}C$ and the ratiometric TC is guaranteed to be within 20ppm/ $^{\circ}C$.

While the data sheet parameters reflect the performance limitations of the digitally controlled potentiometer, there are a large number of circuit techniques that minimize these limitations. Intersil application notes and technical briefs describe these techniques and are available at the Intersil's website www.Intersil.com In addition, these publications describe the myriad of possible applications.

Write Wiper Counter Register (WCR)

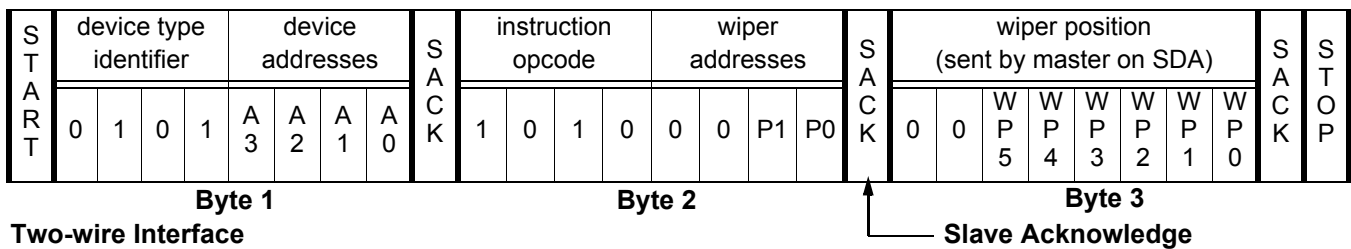

FIGURE 9. BIT STRUCTURE

ANALOG CHARACTERISTICS (Over recommended operating conditions unless otherwise stated.)

Symbol	Parameter		Limits				Test Conditions
			Min.	Typ.	Max.	Units	
R _{TOTAL}	End to End Resistance		-20		+20	%	
	Power Rating				50	mW	25°C, each pot
I _W	Wiper Current		-3		+3	mA	
R _W	Wiper Resistance			40	100	Ω	V _{CC} = 5V, I _W =±1mA
				150	250		V _{CC} = 2.7-5.5V, I _W =±1mA
V _{v+}	Voltage on V+ Pin	X9410	+4.5		+5.5	V	
		X9410-2.7	+2.7		+5.5		
V _{v-}	Voltage on V- Pin	X9410	-5.5		-4.5	V	
		X9410-2.7	-5.5		-2.7		
V _{TERM}	Voltage on any V _H or V _L Pin		V-		V+	V	
	Noise			-140		dBV	Ref: 1kHz
	Resolution (4)			1.6		%	
	Absolute Linearity (1)		-1		+1	MI(3)	V _{w(n)(actual)} - V _{w(n)(expected)}
	Relative Linearity (2)		-0.2		+0.2	MI(3)	V _{w(n+1)} - [V _{w(n)} + MI]
	Temperature Coefficient of R _{TOTAL}			±300		ppm/°C	
	Ratiometric Temp. Coefficient				20	ppm/°C	

- Notes: (1) Absolute Linearity is utilized to determine actual wiper voltage versus expected voltage as determined by wiper position when used as a potentiometer.
(2) Relative Linearity is utilized to determine the actual change in voltage between two successive tap positions when used as a potentiometer. It is a measure of the error in step size.
(3) MI = RTOT/63 or (V_H - V_L)/63, single pot
(4) Individual array resolutions.

FIGURE 10. Analog Data Sheet Parameters

Notice

1. Descriptions of circuits, software and other related information in this document are provided only to illustrate the operation of semiconductor products and application examples. You are fully responsible for the incorporation or any other use of the circuits, software, and information in the design of your product or system. Renesas Electronics disclaims any and all liability for any losses and damages incurred by you or third parties arising from the use of these circuits, software, or information.
2. Renesas Electronics hereby expressly disclaims any warranties against and liability for infringement or any other claims involving patents, copyrights, or other intellectual property rights of third parties, by or arising from the use of Renesas Electronics products or technical information described in this document, including but not limited to, the product data, drawings, charts, programs, algorithms, and application examples.
3. No license, express, implied or otherwise, is granted hereby under any patents, copyrights or other intellectual property rights of Renesas Electronics or others.
4. You shall not alter, modify, copy, or reverse engineer any Renesas Electronics product, whether in whole or in part. Renesas Electronics disclaims any and all liability for any losses or damages incurred by you or third parties arising from such alteration, modification, copying or reverse engineering.
5. Renesas Electronics products are classified according to the following two quality grades: "Standard" and "High Quality". The intended applications for each Renesas Electronics product depends on the product's quality grade, as indicated below.
"Standard": Computers; office equipment; communications equipment; test and measurement equipment; audio and visual equipment; home electronic appliances; machine tools; personal electronic equipment; industrial robots; etc.
"High Quality": Transportation equipment (automobiles, trains, ships, etc.); traffic control (traffic lights); large-scale communication equipment; key financial terminal systems; safety control equipment; etc.
Unless expressly designated as a high reliability product or a product for harsh environments in a Renesas Electronics data sheet or other Renesas Electronics document, Renesas Electronics products are not intended or authorized for use in products or systems that may pose a direct threat to human life or bodily injury (artificial life support devices or systems; surgical implantations; etc.), or may cause serious property damage (space system; undersea repeaters; nuclear power control systems; aircraft control systems; key plant systems; military equipment; etc.). Renesas Electronics disclaims any and all liability for any damages or losses incurred by you or any third parties arising from the use of any Renesas Electronics product that is inconsistent with any Renesas Electronics data sheet, user's manual or other Renesas Electronics document.
6. When using Renesas Electronics products, refer to the latest product information (data sheets, user's manuals, application notes, "General Notes for Handling and Using Semiconductor Devices" in the reliability handbook, etc.), and ensure that usage conditions are within the ranges specified by Renesas Electronics with respect to maximum ratings, operating power supply voltage range, heat dissipation characteristics, installation, etc. Renesas Electronics disclaims any and all liability for any malfunctions, failure or accident arising out of the use of Renesas Electronics products outside of such specified ranges.
7. Although Renesas Electronics endeavors to improve the quality and reliability of Renesas Electronics products, semiconductor products have specific characteristics, such as the occurrence of failure at a certain rate and malfunctions under certain use conditions. Unless designated as a high reliability product or a product for harsh environments in a Renesas Electronics data sheet or other Renesas Electronics document, Renesas Electronics products are not subject to radiation resistance design. You are responsible for implementing safety measures to guard against the possibility of bodily injury, injury or damage caused by fire, and/or danger to the public in the event of a failure or malfunction of Renesas Electronics products, such as safety design for hardware and software, including but not limited to redundancy, fire control and malfunction prevention, appropriate treatment for aging degradation or any other appropriate measures. Because the evaluation of microcomputer software alone is very difficult and impractical, you are responsible for evaluating the safety of the final products or systems manufactured by you.
8. Please contact a Renesas Electronics sales office for details as to environmental matters such as the environmental compatibility of each Renesas Electronics product. You are responsible for carefully and sufficiently investigating applicable laws and regulations that regulate the inclusion or use of controlled substances, including without limitation, the EU RoHS Directive, and using Renesas Electronics products in compliance with all these applicable laws and regulations. Renesas Electronics disclaims any and all liability for damages or losses occurring as a result of your noncompliance with applicable laws and regulations.
9. Renesas Electronics products and technologies shall not be used for or incorporated into any products or systems whose manufacture, use, or sale is prohibited under any applicable domestic or foreign laws or regulations. You shall comply with any applicable export control laws and regulations promulgated and administered by the governments of any countries asserting jurisdiction over the parties or transactions.
10. It is the responsibility of the buyer or distributor of Renesas Electronics products, or any other party who distributes, disposes of, or otherwise sells or transfers the product to a third party, to notify such third party in advance of the contents and conditions set forth in this document.
11. This document shall not be reprinted, reproduced or duplicated in any form, in whole or in part, without prior written consent of Renesas Electronics.
12. Please contact a Renesas Electronics sales office if you have any questions regarding the information contained in this document or Renesas Electronics products.
(Note 1) "Renesas Electronics" as used in this document means Renesas Electronics Corporation and also includes its directly or indirectly controlled subsidiaries.
(Note 2) "Renesas Electronics product(s)" means any product developed or manufactured by or for Renesas Electronics.

(Rev.4.0-1 November 2017)



SALES OFFICES

Renesas Electronics Corporation

<http://www.renesas.com>

Refer to "<http://www.renesas.com/>" for the latest and detailed information.

Renesas Electronics America Inc.
1001 Murphy Ranch Road, Milpitas, CA 95035, U.S.A.
Tel: +1-408-432-8888, Fax: +1-408-434-5351

Renesas Electronics Canada Limited
9251 Yonge Street, Suite 8309 Richmond Hill, Ontario Canada L4C 9T3
Tel: +1-905-237-2004

Renesas Electronics Europe Limited
Dukes Meadow, Millboard Road, Bourne End, Buckinghamshire, SL8 5FH, U.K
Tel: +44-1628-651-700, Fax: +44-1628-651-804

Renesas Electronics Europe GmbH
Arcadiastrasse 10, 40472 Düsseldorf, Germany
Tel: +49-211-6503-0, Fax: +49-211-6503-1327

Renesas Electronics (China) Co., Ltd.
Room 1709 Quantum Plaza, No.27 ZhichunLu, Haidian District, Beijing, 100191 P. R. China
Tel: +86-10-8235-1155, Fax: +86-10-8235-7679

Renesas Electronics (Shanghai) Co., Ltd.
Unit 301, Tower A, Central Towers, 555 Langao Road, Putuo District, Shanghai, 200333 P. R. China
Tel: +86-21-2226-0888, Fax: +86-21-2226-0999

Renesas Electronics Hong Kong Limited
Unit 1601-1611, 16/F., Tower 2, Grand Century Place, 193 Prince Edward Road West, Mongkok, Kowloon, Hong Kong
Tel: +852-2265-6688, Fax: +852-2886-9022

Renesas Electronics Taiwan Co., Ltd.
13F, No. 363, Fu Shing North Road, Taipei 10543, Taiwan
Tel: +886-2-8175-9600, Fax: +886-2-8175-9670

Renesas Electronics Singapore Pte. Ltd.
80 Bendemeer Road, Unit #06-02 Hyflux Innovation Centre, Singapore 339949
Tel: +65-6213-0200, Fax: +65-6213-0300

Renesas Electronics Malaysia Sdn.Bhd.
Unit 1207, Block B, Menara Amcorp, Amcorp Trade Centre, No. 18, Jln Persiaran Barat, 46050 Petaling Jaya, Selangor Darul Ehsan, Malaysia
Tel: +60-3-7955-9390, Fax: +60-3-7955-9510

Renesas Electronics India Pvt. Ltd.
No.777C, 100 Feet Road, HAL 2nd Stage, Indiranagar, Bangalore 560 038, India
Tel: +91-80-67208700, Fax: +91-80-67208777

Renesas Electronics Korea Co., Ltd.
17F, KAMCO Yangjae Tower, 262, Gangnam-daero, Gangnam-gu, Seoul, 06265 Korea
Tel: +82-2-558-3737, Fax: +82-2-558-5338