

Power Supply and DC to DC Converter Control using Intersil Digitally Controlled Potentiometers (XDCPs)

Introduction

The output voltage of power supplies and DC to DC converters is regulated by dividing down the output, comparing it with a stable reference, amplifying the error, and then using this error signal to control the input to output power transfer. Many applications use an expensive and unreliable mechanical potentiometer in the divider to precisely set the output voltage, as shown in Figure 1.

For fixed output supplies, manually adjusting the mechanical pot is a costly and time consuming operation that is prone to error. Physical access to the pot must be provided, which often requires less than optimal PCB layout and additional access holes in the chassis of enclosed units. Though initially set during production, the mechanical pot is subject to shock and vibration, incurring wiper position changes. Humidity and moisture can result in resistive changes and the prying hands of service technicians or end users can also affect accuracy. For variable output supplies, mechanical pots prevent the option of automated or remote adjustment.

To overcome these problems, a potentiometer would have to be electronically programmable in order to eliminate costly and potentially inaccurate manual settings, nonvolatile so as to power-up at the proper setting, and re-programmable for testing in the factory or for adjustments in the field.

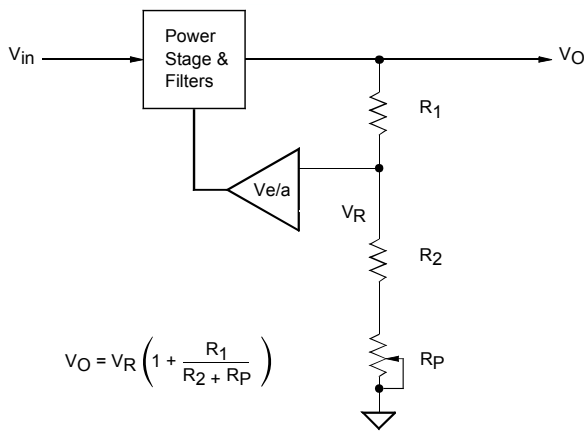

FIGURE 1.

Implementing Designs with XDCPs

An example of a part that meets all of these requirements is the X9CMME from Intersil, shown in Figure 2. This electrically erasable, programmable nonvolatile potentiometer greatly simplifies manufacturing and test, and with a wiper position retention in excess of 100 years, can significantly increase field reliability.

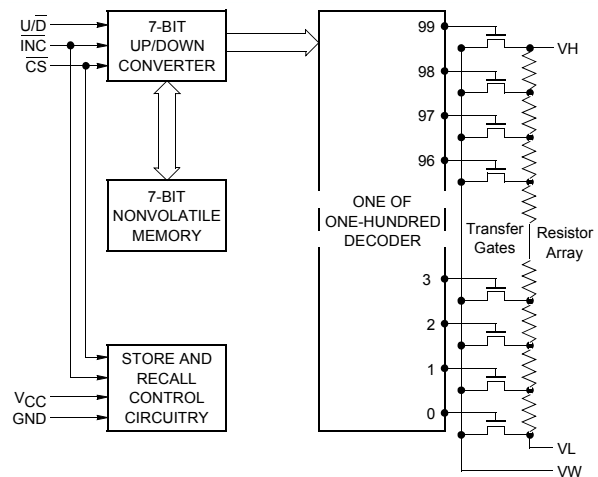

FIGURE 2.

Available in 8-pin DIP or SOIC packages, the 100 wiper position X9CMME is easily implemented into a circuit. Terminal connections are made in the same way as a mechanical pot. The three control lines of the part can be brought out through a connector to automate programming and to test equipment, as shown in Figure 3.

\overline{INC} , $\overline{U/D}$, and \overline{CS} pins control the setting of the wiper. Pulling \overline{CS} LOW enables the part. Each HIGH to LOW transition on the \overline{INC} line increases or decreases (depending on the state of $\overline{U/D}$) the resistance of the pot. After reaching the desired output voltage, the final wiper setting can be stored in nonvolatile memory by bringing \overline{CS} HIGH while \overline{INC} is HIGH. This ensures that the X9CMME powers-up at the last setting. It may appear that this is the only operating sequence for power supply applications, but there is at least one important scenario where wiper position storage is not required.

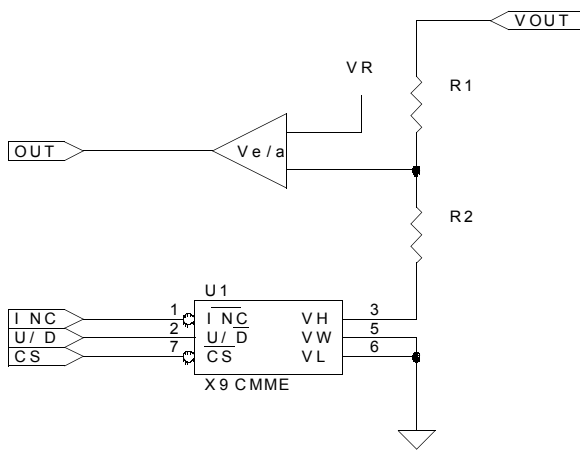

FIGURE 3.

Overvoltage Testing

Overvoltage (OV) testing has always presented a challenge to the manufacturing engineer. If a mechanical potentiometer is available, it must be adjusted manually to test the OV protection circuitry and then be readjusted to reset the output voltage. If there is no potentiometer in the system, or even if there is one that is not easily accessible, an external power supply must be connected to the unit under test (UUT). The voltage on the external supply is then raised while monitoring the UUT, to determine the point at which it shuts down. This often requires observation of waveforms internal to the UUT that are also difficult to access, compounded by the fact that the UUT control circuitry may obscure the response of the OV protection circuitry. This cumbersome procedure can be eliminated through the use of XDCPs.

If the output voltage in Figure 3 is 5V, with a 2.5V reference, and R1 is 10k Ω and R2 is 4.99k Ω , a good choice of XDCP for voltage regulation and overvoltage testing would be the X9C103 (10k Ω version of the X9CMME). Having adjusted the output voltage to meet spec. at some nominal line and load, and after storing this setting in nonvolatile memory by deselecting the part with $\overline{\text{INC}}$ HIGH, the testing of the power supply can begin. When the OV portion of the test is reached, the output voltage is increased by toggling the INC pin of the XDCP while holding $\overline{\text{U/D}}$ LOW. Upon reaching the OV trip point and the supply shutting-down, the final value of the output voltage can be automatically recorded and compared to a maximum allowable value. The automatic test equipment (ATE) could then generate a pass/fail response. Provided $\overline{\text{CS}}$ does not transition from HIGH to LOW with $\overline{\text{INC}}$ HIGH, the OV trip point wiper position will not be stored and the XDCP will return to the previously calibrated regulation voltage upon power-up. This approach provides an accurate, automated means of overvoltage testing.

The X9CMME provides 100 tap positions for terminal voltages of $\pm 5\text{V}$ and is available in 1k Ω , 10k Ω , 50k Ω , and 100k Ω versions. The X9312 gives an extended 0 to 15V terminal voltage capability and the X9313 provides an inexpensive 32 tap alternative. All single XDCPs share the same pinout and are available in DIP and SOIC packages.

Quad XDCP

For multiple output power supplies or in applications where resolution greater than 100 wiper positions is required, Intersil offers the X9241 quad XDCP, shown in Figure 4. Designed to interface directly with a microcontroller, the X9241 can be directly programmed with a wiper position or incremented/decremented tap-by-tap like the X9CMME.

The X9241 contains four 64 wiper position pots in a single 20 pin package. Each pot has a wiper counter register (WCR) that controls the wiper position and four nonvolatile registers that store wiper settings. The part provides four pins for device addressing, allowing as many as 16 devices to share the same bus, using an instruction oriented protocol. Registers and wiper positions can be read and written by the ATE using a two-wire bidirectional serial interface.

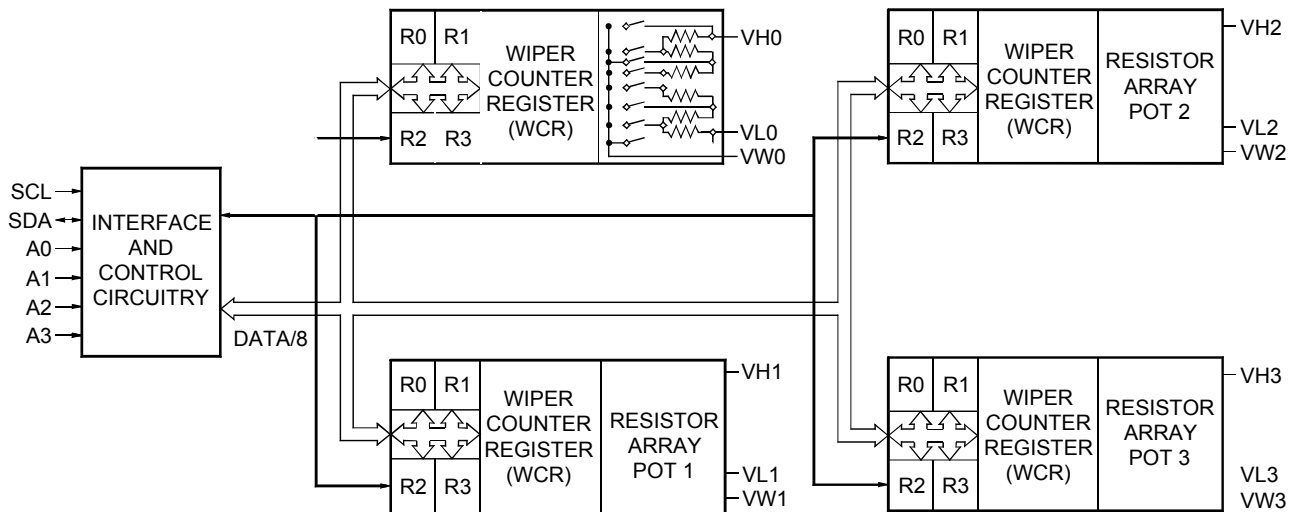

FIGURE 4.

Internal support is available for cascading pots together in series or parallel to increase resolution and provide larger or smaller potentiometer values. These cascading configurations can be implemented in any number of ways using two or more pots. For example, using the X9241M (2kΩ, 10kΩ, 10kΩ, 50kΩ combo version), two pots to can be used to give a fine and course adjustment for setting the regulated output voltage and testing the overvoltage circuitry. This configuration is shown in Figure 5. Pot 3 can be used to provide course adjustment with 800W (50kΩ/63) steps and pot 0 to provide fine adjustment with 32W (2kΩ/63) steps. The wiper position is changed using the increment/decrement or write WCR commands. Wiper settings are stored in nonvolatile memory by directly writing to data registers or transferring data from WCRs to data registers. Each pots' WCR is loaded with contents of data register 0 upon power-up.

The X9241 is a ±5V terminal device available in 2kΩ, 10kΩ, 50kΩ, and combination versions, with either DIP or SOIC package options. This digitally controlled IC greatly simplifies and automates manufacturing and test. Like the X9CMME, nonvolatile storage retention of the X9241 is at least 100 years, providing a significant increase in field reliability.

Conclusion

Nonvolatile XDCPs provide significant advantages over mechanical potentiometers for power supplies in both manufacturing and in the field. Automated assembly and test provide labor savings, while increasing repeatability and eliminating human error. Immune to shock and vibration, and with superior resistance to environmental stress, XDCPs increase long term reliability. In the never ending struggle to cut costs and increase quality, Intersil XDCPs are a major enhancement in the design of power supplies and DC to DC converters.

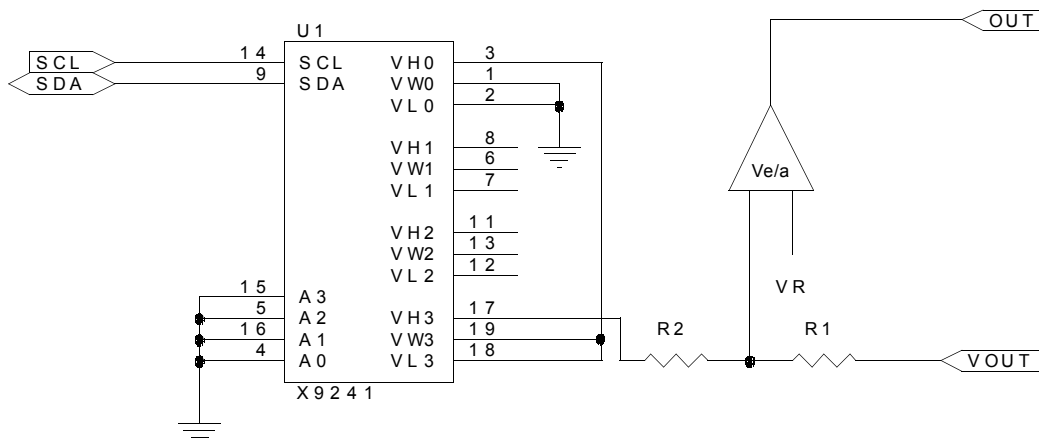

FIGURE 5.

Notice

1. Descriptions of circuits, software and other related information in this document are provided only to illustrate the operation of semiconductor products and application examples. You are fully responsible for the incorporation or any other use of the circuits, software, and information in the design of your product or system. Renesas Electronics disclaims any and all liability for any losses and damages incurred by you or third parties arising from the use of these circuits, software, or information.
2. Renesas Electronics hereby expressly disclaims any warranties against and liability for infringement or any other claims involving patents, copyrights, or other intellectual property rights of third parties, by or arising from the use of Renesas Electronics products or technical information described in this document, including but not limited to, the product data, drawings, charts, programs, algorithms, and application examples.
3. No license, express, implied or otherwise, is granted hereby under any patents, copyrights or other intellectual property rights of Renesas Electronics or others.
4. You shall not alter, modify, copy, or reverse engineer any Renesas Electronics product, whether in whole or in part. Renesas Electronics disclaims any and all liability for any losses or damages incurred by you or third parties arising from such alteration, modification, copying or reverse engineering.
5. Renesas Electronics products are classified according to the following two quality grades: "Standard" and "High Quality". The intended applications for each Renesas Electronics product depends on the product's quality grade, as indicated below.
"Standard": Computers; office equipment; communications equipment; test and measurement equipment; audio and visual equipment; home electronic appliances; machine tools; personal electronic equipment; industrial robots; etc.
"High Quality": Transportation equipment (automobiles, trains, ships, etc.); traffic control (traffic lights); large-scale communication equipment; key financial terminal systems; safety control equipment; etc.
Unless expressly designated as a high reliability product or a product for harsh environments in a Renesas Electronics data sheet or other Renesas Electronics document, Renesas Electronics products are not intended or authorized for use in products or systems that may pose a direct threat to human life or bodily injury (artificial life support devices or systems; surgical implantations; etc.), or may cause serious property damage (space system; undersea repeaters; nuclear power control systems; aircraft control systems; key plant systems; military equipment; etc.). Renesas Electronics disclaims any and all liability for any damages or losses incurred by you or any third parties arising from the use of any Renesas Electronics product that is inconsistent with any Renesas Electronics data sheet, user's manual or other Renesas Electronics document.
6. When using Renesas Electronics products, refer to the latest product information (data sheets, user's manuals, application notes, "General Notes for Handling and Using Semiconductor Devices" in the reliability handbook, etc.), and ensure that usage conditions are within the ranges specified by Renesas Electronics with respect to maximum ratings, operating power supply voltage range, heat dissipation characteristics, installation, etc. Renesas Electronics disclaims any and all liability for any malfunctions, failure or accident arising out of the use of Renesas Electronics products outside of such specified ranges.
7. Although Renesas Electronics endeavors to improve the quality and reliability of Renesas Electronics products, semiconductor products have specific characteristics, such as the occurrence of failure at a certain rate and malfunctions under certain use conditions. Unless designated as a high reliability product or a product for harsh environments in a Renesas Electronics data sheet or other Renesas Electronics document, Renesas Electronics products are not subject to radiation resistance design. You are responsible for implementing safety measures to guard against the possibility of bodily injury, injury or damage caused by fire, and/or danger to the public in the event of a failure or malfunction of Renesas Electronics products, such as safety design for hardware and software, including but not limited to redundancy, fire control and malfunction prevention, appropriate treatment for aging degradation or any other appropriate measures. Because the evaluation of microcomputer software alone is very difficult and impractical, you are responsible for evaluating the safety of the final products or systems manufactured by you.
8. Please contact a Renesas Electronics sales office for details as to environmental matters such as the environmental compatibility of each Renesas Electronics product. You are responsible for carefully and sufficiently investigating applicable laws and regulations that regulate the inclusion or use of controlled substances, including without limitation, the EU RoHS Directive, and using Renesas Electronics products in compliance with all these applicable laws and regulations. Renesas Electronics disclaims any and all liability for damages or losses occurring as a result of your noncompliance with applicable laws and regulations.
9. Renesas Electronics products and technologies shall not be used for or incorporated into any products or systems whose manufacture, use, or sale is prohibited under any applicable domestic or foreign laws or regulations. You shall comply with any applicable export control laws and regulations promulgated and administered by the governments of any countries asserting jurisdiction over the parties or transactions.
10. It is the responsibility of the buyer or distributor of Renesas Electronics products, or any other party who distributes, disposes of, or otherwise sells or transfers the product to a third party, to notify such third party in advance of the contents and conditions set forth in this document.
11. This document shall not be reprinted, reproduced or duplicated in any form, in whole or in part, without prior written consent of Renesas Electronics.
12. Please contact a Renesas Electronics sales office if you have any questions regarding the information contained in this document or Renesas Electronics products.
(Note 1) "Renesas Electronics" as used in this document means Renesas Electronics Corporation and also includes its directly or indirectly controlled subsidiaries.
(Note 2) "Renesas Electronics product(s)" means any product developed or manufactured by or for Renesas Electronics.

(Rev.4.0-1 November 2017)



SALES OFFICES

Renesas Electronics Corporation

<http://www.renesas.com>

Refer to "<http://www.renesas.com/>" for the latest and detailed information.

Renesas Electronics America Inc.
1001 Murphy Ranch Road, Milpitas, CA 95035, U.S.A.
Tel: +1-408-432-8888, Fax: +1-408-434-5351

Renesas Electronics Canada Limited
9251 Yonge Street, Suite 8309 Richmond Hill, Ontario Canada L4C 9T3
Tel: +1-905-237-2004

Renesas Electronics Europe Limited
Dukes Meadow, Millboard Road, Bourne End, Buckinghamshire, SL8 5FH, U.K
Tel: +44-1628-651-700, Fax: +44-1628-651-804

Renesas Electronics Europe GmbH
Arcadiastrasse 10, 40472 Düsseldorf, Germany
Tel: +49-211-6503-0, Fax: +49-211-6503-1327

Renesas Electronics (China) Co., Ltd.
Room 1709 Quantum Plaza, No.27 ZhichunLu, Haidian District, Beijing, 100191 P. R. China
Tel: +86-10-8235-1155, Fax: +86-10-8235-7679

Renesas Electronics (Shanghai) Co., Ltd.
Unit 301, Tower A, Central Towers, 555 Langao Road, Putuo District, Shanghai, 200333 P. R. China
Tel: +86-21-2226-0888, Fax: +86-21-2226-0999

Renesas Electronics Hong Kong Limited
Unit 1601-1611, 16/F., Tower 2, Grand Century Place, 193 Prince Edward Road West, Mongkok, Kowloon, Hong Kong
Tel: +852-2265-6688, Fax: +852-2886-9022

Renesas Electronics Taiwan Co., Ltd.
13F, No. 363, Fu Shing North Road, Taipei 10543, Taiwan
Tel: +886-2-8175-9600, Fax: +886-2-8175-9670

Renesas Electronics Singapore Pte. Ltd.
80 Bendemeer Road, Unit #06-02 Hyflux Innovation Centre, Singapore 339949
Tel: +65-6213-0200, Fax: +65-6213-0300

Renesas Electronics Malaysia Sdn.Bhd.
Unit 1207, Block B, Menara Amcorp, Amcorp Trade Centre, No. 18, Jln Persiaran Barat, 46050 Petaling Jaya, Selangor Darul Ehsan, Malaysia
Tel: +60-3-7955-9390, Fax: +60-3-7955-9510

Renesas Electronics India Pvt. Ltd.
No.777C, 100 Feet Road, HAL 2nd Stage, Indiranagar, Bangalore 560 038, India
Tel: +91-80-67208700, Fax: +91-80-67208777

Renesas Electronics Korea Co., Ltd.
17F, KAMCO Yangjae Tower, 262, Gangnam-daero, Gangnam-gu, Seoul, 06265 Korea
Tel: +82-2-558-3737, Fax: +82-2-558-5338