

## Introduction

System reliability is one of the most emphasized qualities of any telecommunication applications. Redundancy is utilized to improve telecommunication systems' reliability. When a card or a port fails, a redundant card or port shall be switched into the system without interrupting system data continuity. IDT SuperJet and ULIU products have integrated internal termination resistance inside the chips for universal T1/E1/J1 impedance matching, and yet a fixed external resistor is required to complete the termination circuit. This document attempts to provide help for system designers to implement redundancy using IDT products.

## Summary

Redundancy is a much requested feature in telecom applications. IDT's recently released HD-LIU family products have built in fully internal termination features that enable total relay-less redundancy for HPS applications. However, earlier released ULIU (universal LIU) and transceiver (SuperJet) devices require an external resistor for different termination schemes. This note provides some recommendations for redundancy implementations for designs that employ SuperJet transceivers and ULIU devices.

## Redundancy Schemes

Based on different system conditions, different redundancy schemes are proposed. In each redundancy scheme proposal, it is assumed that transmit direction will be put in High-Z state for redundant card. Therefore, the following diagram figures show only the receive direction of the line.

### (1) Systems with a Separate I/O Card for Magnetic

Figure 1 shows a scheme used for designs that allow a separate I/O card on which magnetic component and an external resistor reside.

Figure 1. System Redundancy with Separate I/O Card ( $R_r = 120\Omega$ )

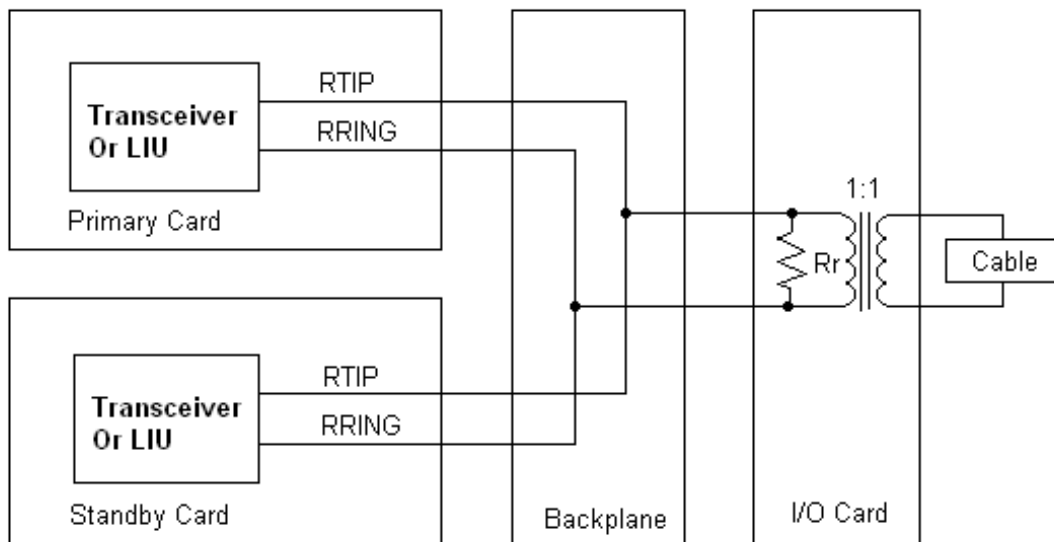

In this configuration, primary card is in normal operation while Standby card is configured to be in high-impedance state. When primary card fails, standby card will be switched to "working mode" from high-impedance state within 2 $\mu$ s.

The switch-over applies to both transmit and receive.

**(2) Systems with Y-cable Patch Panel**

In some other systems, there is no separate I/O card. Magnetic component (transformer) will reside in the same board with the transceiver or LIU chip. If so, there are two different ways to handle the external termination resistor. Figure 2 illustrates a scheme where TIP/RING leads are connected after the transformer forming a Y-shaped cable connection. In this case, a Y-cable patch-panel is expected.

**Figure 2. Redundancy Scheme with Individual Magnetic and Shared Termination Resistor by Y-cable Patch-panel ( $R_r = 120\Omega$ )**

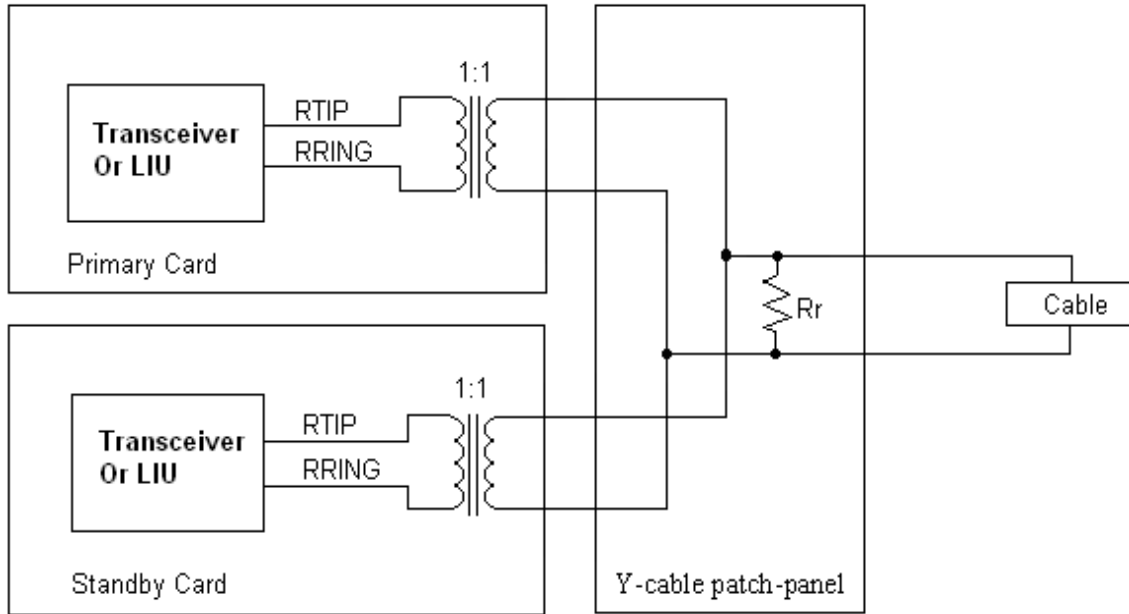

In normal applications, it is recommended that the external termination resistor be as close to the chip as possible. However, with proper layout placement and impedance control, and Y-cable length being less than 1ft, both lab test and simulation indicate acceptable results.

**(3) Systems without an I/O card or Y-cable Patch Panel**

Figure 3 shows a scheme where neither a separate I/O card, nor a Y-cable patch-panel exists. An external resistor lies between the chip and the transformer for both primary card and Standby card. Because TIP/RING leads for two cards are connected together after the transformer, two resistors are essentially in parallel thus changing the impedance matching. Therefore, the resistor on Standby card needs to be switched out. A solid-state analog switch can be used to switch the resistor in or out, as shown in Figure 3.

Figure 3. A Regular Redundant System Employing Analog Switches ( $R_r = 120\Omega$ )

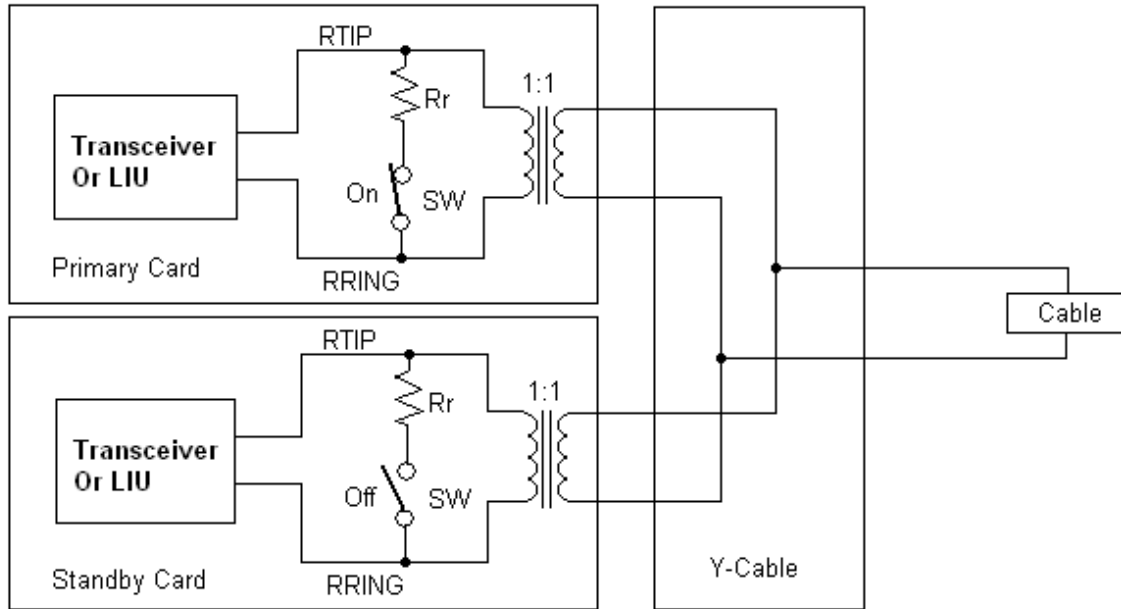

In Figure 3, primary card is in normal operation with  $120\Omega$  resistor switched in the circuit. Standby card, on the other hand, is in high impedance state, and its resistor is switched out of the circuit by the analog switch. Upon primary card failure, Standby card will return to normal operation (from high-impedance state) and its external resistor is switched in. The opposite will occur in primary card.

**(4) Systems without an I/O card or Y-cable Patch Panel that Require “Sniffing”**

Sometimes there requires an application where a “sniffing” feature (a standby card also serves as a line condition monitor) is preferred from a redundant system. As shown in Figure 4, an application proposal is made to achieve just that by using analog switches and attenuation resistors. In Figure 4, analog switches are configured as such that the primary card is operational in normal mode while standby card, while serving as a redundant card upon the failure of primary card, is monitoring the line condition through a  $432\Omega$  resistor simulating a high-impedance bridging circuit commonly used in a digital cross-connect settings. The  $432\Omega$  resistor is used to avoid interfering signals in primary card. SuperJet has built in a Monitor Gain circuit which is able to amplify the attenuated signal by 22dB/26dB/32dB configurable by software.

Figure 4. Redundancy with Line Monitoring

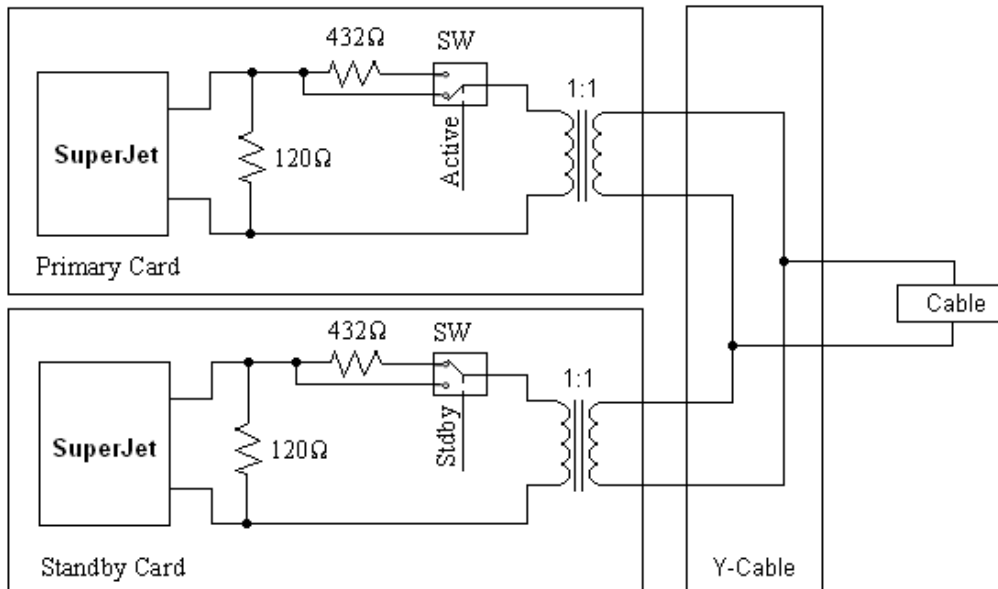

## Appendix

A solid state analog switch can adequately fit into this requirement with the following features:

1. Tiny, compatible packages, i.e. SC70/SOT-23, normally 2x2mm, with single supply.
2. Sub-ohm resistance when ON; Very high resistance when OFF.
3. Extremely fast switching speed, normally 25~40 nanoseconds.
4. In this application, power consumption can be as low as 10mW

**Table 1: A Sampling of Off-the-Shelf Analog Switches**

Part #/Vendor	Ron (Ohm)	Switching Speed	Package Size	Supply
Vishay, DG3001	0.4	47ns	1.5mmx1mm	3.3V
Vishay DT2715	0.4	25ns	SC70, 2x2mm	3.3V
Maxim MAX4715	0.4	18ns	SC70, 2x2mm	3.3V
Maxim MAX4626	0.9	50ns	SOT23-5	3.3V
NEC PS7802	1.1	0.1ms	4.2mmx2.5mm	3.3V



## IMPORTANT NOTICE AND DISCLAIMER

RENESAS ELECTRONICS CORPORATION AND ITS SUBSIDIARIES (“RENESAS”) PROVIDES TECHNICAL SPECIFICATIONS AND RELIABILITY DATA (INCLUDING DATASHEETS), DESIGN RESOURCES (INCLUDING REFERENCE DESIGNS), APPLICATION OR OTHER DESIGN ADVICE, WEB TOOLS, SAFETY INFORMATION, AND OTHER RESOURCES “AS IS” AND WITH ALL FAULTS, AND DISCLAIMS ALL WARRANTIES, EXPRESS OR IMPLIED, INCLUDING, WITHOUT LIMITATION, ANY IMPLIED WARRANTIES OF MERCHANTABILITY, FITNESS FOR A PARTICULAR PURPOSE, OR NON-INFRINGEMENT OF THIRD PARTY INTELLECTUAL PROPERTY RIGHTS.

These resources are intended for developers skilled in the art designing with Renesas products. You are solely responsible for (1) selecting the appropriate products for your application, (2) designing, validating, and testing your application, and (3) ensuring your application meets applicable standards, and any other safety, security, or other requirements. These resources are subject to change without notice. Renesas grants you permission to use these resources only for development of an application that uses Renesas products. Other reproduction or use of these resources is strictly prohibited. No license is granted to any other Renesas intellectual property or to any third party intellectual property. Renesas disclaims responsibility for, and you will fully indemnify Renesas and its representatives against, any claims, damages, costs, losses, or liabilities arising out of your use of these resources. Renesas' products are provided only subject to Renesas' Terms and Conditions of Sale or other applicable terms agreed to in writing. No use of any Renesas resources expands or otherwise alters any applicable warranties or warranty disclaimers for these products.

(Disclaimer Rev.1.0 Mar 2020)

### Corporate Headquarters

TOYOSU FORESIA, 3-2-24 Toyosu,  
Koto-ku, Tokyo 135-0061, Japan  
[www.renesas.com](http://www.renesas.com)

### Contact Information

For further information on a product, technology, the most up-to-date version of a document, or your nearest sales office, please visit:  
[www.renesas.com/contact/](http://www.renesas.com/contact/)

### Trademarks

Renesas and the Renesas logo are trademarks of Renesas Electronics Corporation. All trademarks and registered trademarks are the property of their respective owners.