

### Notes

By Alex Medvedev

## Introduction

The purpose of this Application Note is to provide detail on how to perform and gather power consumption measurements for the IDT Family of PCI Express® I/O Connectivity Switches. This Application Note provides information for the following IDT device evaluation boards: PES8T5, PES12N3, PES12N3A, PES16T4, PES16T7, PES24N3, PES24N3A, PES24T6, and PES32T8. These boards are referred to as Switch Evaluation Boards in this document.

**Note:** For the PES12N3 and PES24N3, the procedures in this document apply to evaluation boards labeled 18-597-001 and 18-590-002 respectively. Users of PES12N3 or PES24N3 evaluation boards with other labels should contact the IDT help desk at [ssdhelp@idt.com](mailto:ssdhelp@idt.com) for additional information.

## Major Components

The following is a list of major components used in the power consumption measurement setup:

- AdexElec PE-FLEX8 12" cables
- Intel Lindenhurst based system or compatible system with at least one x8 PCIe Slot
- HP E3631A Triple Output Power Supplies
- LeCroy Protocol Analyzer System - Model 100K
- IDT PCIe Switch Evaluation Board (I/O Connectivity Family only)
- Fluke 179 True RMS Multi-meters
- Multiple banana-to-test clip cables
- 5 High Performance Fiber Channel (HPFC) Cards (preferably PMC-Sierra HPFC6440 (QX4)) w/ Multiple LC-LC Cables

## Basic Setup

For Switch Evaluation Boards PES8T5, PES12N3A, and the PES16T4:

- plug the LeCroy Analyzer Interposer Card into a x4 unpopulated PCI Express port on the motherboard.

For Switch Evaluation Boards PES16T7, PES24N3, PES24T6, and PES32T8:

- plug the LeCroy Analyzer Interposer Card into a x8 port on the motherboard.

When the LeCroy card has been plugged in, perform the following steps:

1. Connect the LeCroy Interposer Card to the LeCroy Protocol Analyzer using the LeCroy Interposer Card Cables. The LeCroy Protocol Analyzer should be connected to a system that is running the PETracer software application.
2. Plug the upstream port of the Switch Evaluation Board into the LeCroy Interposer Card.
3. Populate all of the downstream ports on the Switch Evaluation Board with HPFC Cards either directly or using Flex Cables. In some cases, 8-to-1 PCIe lane reducers may be needed to populate the x1 downstream ports of the PES8T5 and PES16T7 Evaluation Boards.

## Notes

4. Connect all the ports of the HPFC Cards together using LC-LC Cables (see Figure 1). Either connect the HPFC Cards together (see Figure 2) or connect each HPFC Card in loop-back fashion (see Figure 3).
5. Install the appropriate drivers for the HPFC Cards. Make sure that for each LC-LC cable connection one HPFC port is setup as an initiator and the other is setup as a target (disk volume).
6. Remove the following jumper shunts from the Switch Evaluation Board: W10, W22, W23, W24, and W25.
7. Using a banana-to-test clip see Figure 4), connect the GND of one of the Adjustable DC Power Supplies to a GND pin on the Switch Evaluation Board (TP6 on most Eval. Boards).
8. Connect the GND ports of the Adjustable DC Power Supplies together.

**Note:** Each of the following five voltages must be connected to an Adjustable DC Power Supply using banana-to-test clips:  $V_{DDCORE}$ ,  $V_{DDPE}$ ,  $V_{TTPE}$ ,  $V_{DDAPE}$ ,  $V_{DDIO}$  (refer to section Taking Measurements on page 1-6 for instructions).



Figure 1 LC-LC Cables

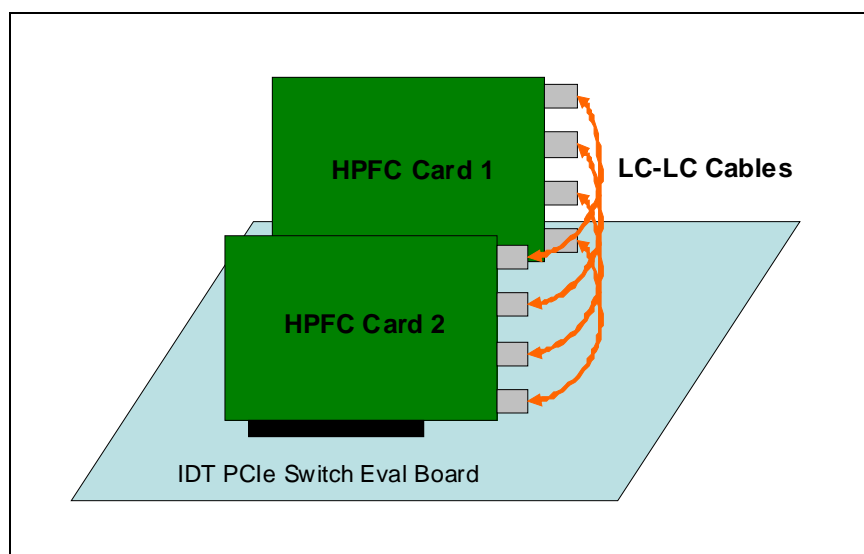

Figure 2 Two HPFC Cards Connected Together

Notes

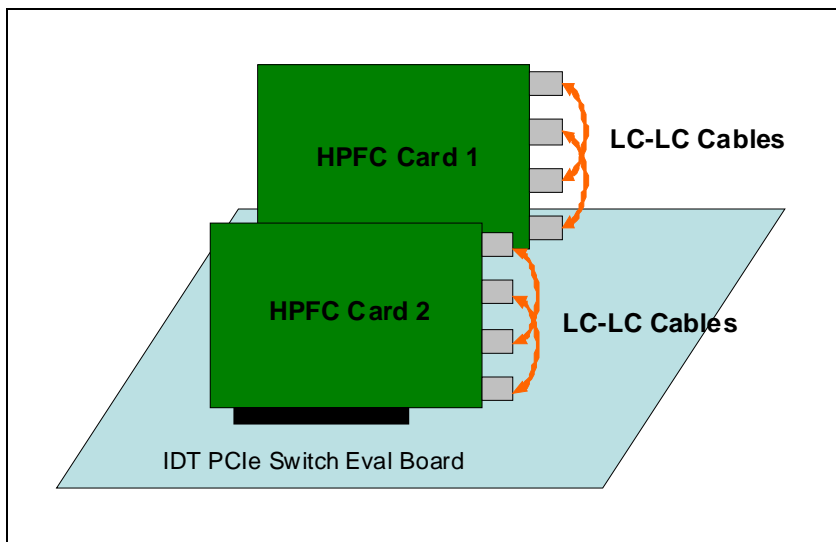

Figure 3 Two HPFC Cards Connected in Loop-back



Figure 4 Banana-to-Test Clips

- Depending on whether the test scenario is for typical or maximum power, adjust the on-board voltages to the values shown in Table 1.

	Typical Value	Max. Value
$V_{DDCORE}$	1.0 V	1.1 V
$V_{DDPE}$	1.0 V	1.1 V
$V_{TTPE}$	1.5 V	1.575 V
$V_{DDAPE}$	1.0 V	1.1 V
$V_{DDIO}$	3.3 V	3.465 V

Table 1 Typical and Maximum Voltage Values

The setup is shown in Figure 5. When the system has been correctly setup, it is ready to be turned on.

## Notes

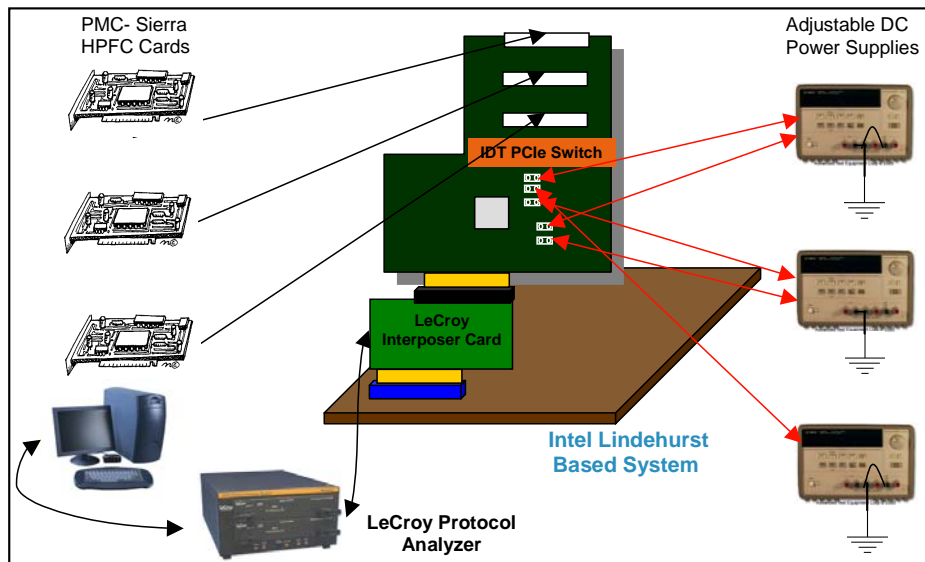

Figure 5 Power Consumption Setup

The system has now been properly set up and is ready to operate. The following sections will provide a detailed explanation of:

- how to connect and supply external power to the Switch Evaluation Board, if it is needed
- how to set up the LeCroy Protocol Analyzer in order to keep track of link utilization on the upstream port of the Switch Evaluation Board
- how to take the actual power consumption measurements
- how to achieve the desired bidirectional link utilization on the upstream port of the Switch Evaluation Board in order to satisfy the requirements for typical and maximum power consumption measurements.

## Supplying External Power

The IDT PCIe Switch Evaluation Boards and all attached endpoint cards are powered entirely by the host system through the upstream PCI Express edge connector. In general, this is sufficient. However, in cases where the combined power requirements of the Switch Evaluation Board and the devices attached to its downstream ports exceed PCI Express specifications, an external power source may be required to supply the necessary power.

### External Power Source

The standard power connector can be found on any ATX Power Supply, as shown in Figure 6.

Notes

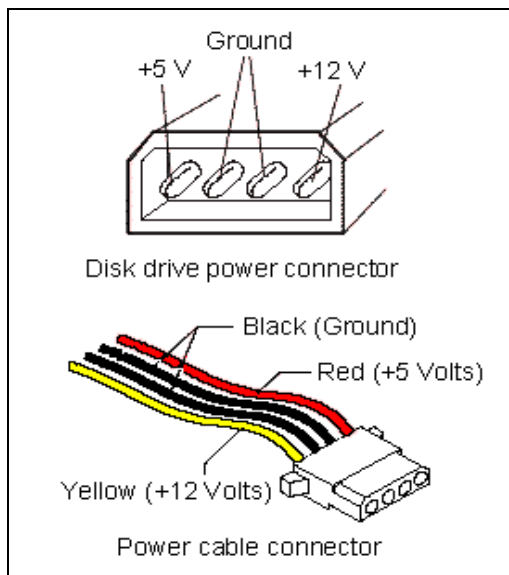

Figure 6 Power Connector on ATX Power Supply

Plug the external power connector into J1 of the Switch Evaluation Board. (Note that the +5V is not used by the Switch Evaluation Board). Set the following jumpers as indicated in Table 2.

Switch Evaluation Board	Jumper	Shunt	Description
PES12N3 <sup>1</sup> , PES24N3 <sup>2</sup> PES12N3A, PES24N3A	W7-W9 and W12	2-3	12.0V & 3.3V sources from external power connector
PES8T5, PES16T4, PES16T7, PES24T6, PES32T8	W45-47	2-3	12.0V source from external power connector

Table 2 Jumper Selection for Use of External Power Source

<sup>1</sup> For Evaluation Boards labeled 18-597-001 only.

<sup>2</sup> For Evaluation Boards labeled 18-590-002 only.

## LeCroy Protocol Analyzer Setup

**Note:** The LeCroy Analyzer Interposer Card is going to sit in between the motherboard of the system and the Switch Evaluation Board.

1. Make sure that the LeCroy Protocol Analyzer is connected to the LeCroy Interposer Card.
2. Turn on the System and the LeCroy Protocol Analyzer.
3. Using a USB Cable, connect a Laptop or a PC to the LeCroy Analyzer.
4. Run the LeCroy PETracer Utility on the laptop or PC from the previous step.
5. In the LeCroy PETracer Utility, pull down the Setup Menu and click on Recording Options.
6. Under the General tab of the Recording Option, set the link to either x8 or x4, depending on the DUT.
7. In the same window, check the Use External Reference Clock box and the Auto-Configure Lane Polarity box.
8. Hit OK.
9. Open up Real Time Statistics. A graph will be displayed showing real time link utilization (see Figure 11). The link utilization for both the upstream and downstream directions should be less than 1% each.

## Notes

Provided that everything works properly, the PETracer will keep track of link utilization on the upstream port of the switch evaluation board. As more bidirectional link traffic goes through the Switch Evaluation Board, the link utilization rate should rise for both the upstream and downstream directions.

## Taking Measurements

Total Power Consumption for the IDT PCIe Switch is determined by measuring the current drawn by five Operating Supply Voltages on the Switch Evaluation Board and multiplying each of those currents by their corresponding voltages.

The Five Voltages can be found at the outputs of the following Voltage Converters:

- PCI Express Serial Data Transmit Termination Voltage Converter  
A DC-DC converter provides a 1.5V PCI Express serial data transmit termination voltage to the Switch IC on the Switch Evaluation Board.
- PCI Express Digital Power Voltage Converter  
A separate DC-DC converter provides a 1.0V PCI Express digital power voltage to the Switch IC on the Switch Evaluation Board.
- PCI Express Analog Power Voltage Converter  
A separate DC-DC converter provides a 1.0V PCI Express analog power voltage to the Switch IC on the Switch Evaluation Board.
- Core Logic Voltage Converter  
A separate DC-DC converter provides the 1.0V core voltage to the Switch IC on the Switch Evaluation Board.
- 3.3V I/O Power Module  
A 12V to 3.3V power module provides the 3.3V I/O voltage to the Switch IC on the Switch Evaluation Board.

Table 3 shows the location of each of the five operating supply voltages on the IDT Switch Evaluation Boards.

	Typical Voltage	Jumper
V <sub>DD</sub> CORE	1.0 V	W25
V <sub>DD</sub> PE	1.0 V	W22
V <sub>TT</sub> PE	1.5 V	W23
V <sub>DD</sub> APE	1.0 V	W24
V <sub>DD</sub> IO	3.3 V	W10

Table 3 Typical and Maximum Voltage Values

Total Power Consumption of the IDT PCIe Switch will be calculated from the following formula:

$$\text{Total Power Consumption} = (V_{DD}CORE * I_{DD}CORE) + (V_{DD}PE * I_{DD}PE) + (V_{TT}PE * I_{TT}PE) + (V_{DD}APE * I_{DD}APE) + (V_{DD}IO * I_{DD}IO)$$

**Note:** Since I<sub>DD</sub>IO is typically no more than one mA, its effect on Total Power Consumption is practically negligible.

To find the current at each of the five operating voltage supplies, simply place an Adjustable DC Power Supply with an Ammeter at the Jumper that corresponds to each operating voltage supply (Jumper shunt needs to be removed), as shown in Figures 7 and 8.

Notes

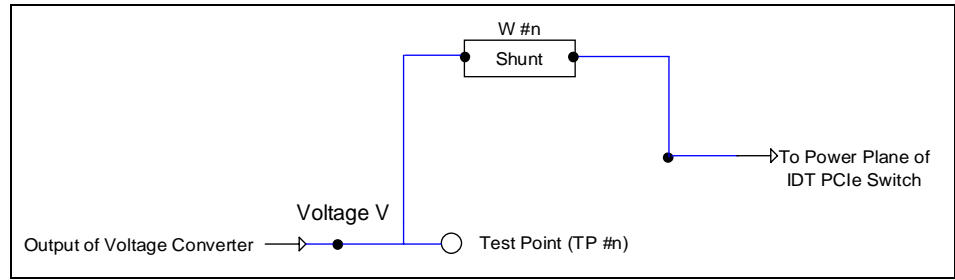

Figure 7 Before Applying an Adjustable DC Power Supply

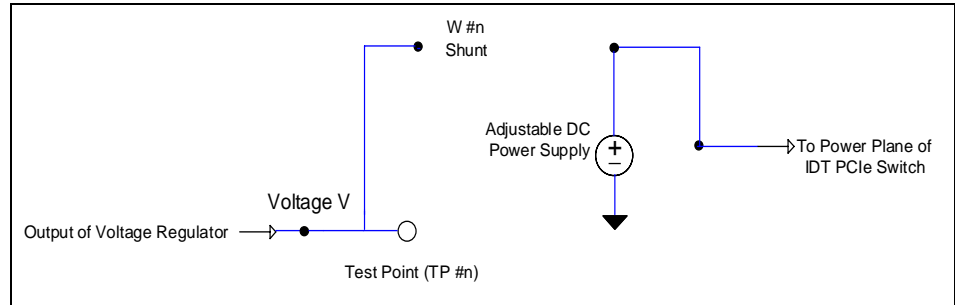

Figure 8 After Applying an Adjustable DC Power Supply

In order to connect the adjustable DC power supply to the correct pin on the two-pin jumper, measure the resistance between each of the two pins of the jumper and the test point that is associated with that jumper on the switch evaluation board. Connect the adjustable DC power supply to the pin on the two-pin jumper that is not tied to the test point. Refer to the Table 4.

	Typical Voltage	Jumper	PES12N3A & PES24N3A Test Point	Test Point on all other boards
V <sub>DD</sub> CORE	1.0 V	W25	TP18	TP1
V <sub>DD</sub> PE	1.0 V	W22	TP22	TP4
V <sub>TT</sub> PE	1.5 V	W23	TP23	TP5
V <sub>DD</sub> APE	1.0 V	W24	TP24	TP7
V <sub>DD</sub> IO	3.3 V	W10	No Test Point	No Test Point

Table 4 Test Points Associated with Each Jumper

Typically, there is some discrepancy between the voltages put out by the adjustable power supplies and the actual voltages seen by the switch evaluation board. Therefore, the voltages on the switch evaluation board need to be monitored with voltmeters (or multi-meters). Attach the voltmeter probes to the same points (jumper pins) where adjustable power supplies were applied. To ground the voltmeters, use the GND pin as described in step 7 in section Basic Setup on page 1-1.

### Link Utilization

PMC-Sierra HPFC6440 (QX4) Cards were used to create traffic in the Switch Evaluation Board. Increased Link Utilization (traffic) in the Switch Evaluation Board increases the current drawn by the core voltage operating supply (V<sub>DD</sub>CORE) of the Switch IC. Each HPFC6440 card has four 4Gbps Fiber ports.

## Notes

Four ports on each card were interconnected, creating a total of two loop-back connections per HPFC6440 card. Each connection is able to simulate a physical volume (Hard Disk). Traffic was run to and from these physical volumes using the Iometer Software Utility. The link utilization on the upstream port of the switch evaluation board was monitored using the LeCroy Protocol Analyzer.

### Typical Link Utilization Case

Typical power is measured under the following conditions: 25°C Ambient, 35% total link usage on the upstream port.

1. If the HPFC Cards are setup properly, when the Iometer is opened it should display several physical volumes in addition to whatever Hard Disks are physically present in the system (see Figure 9). If the physical volumes that represent the HPFC Cards are not displayed, go into the disk manager and delete any partitions that may be present on these physical drives.
2. In the Iometer window, assign a worker to one or two of the visible physical volumes shown in Figure 9.
3. Set the Maximum Disk Size to 1024 Sectors and leave the # of Outstanding I/Os at one.

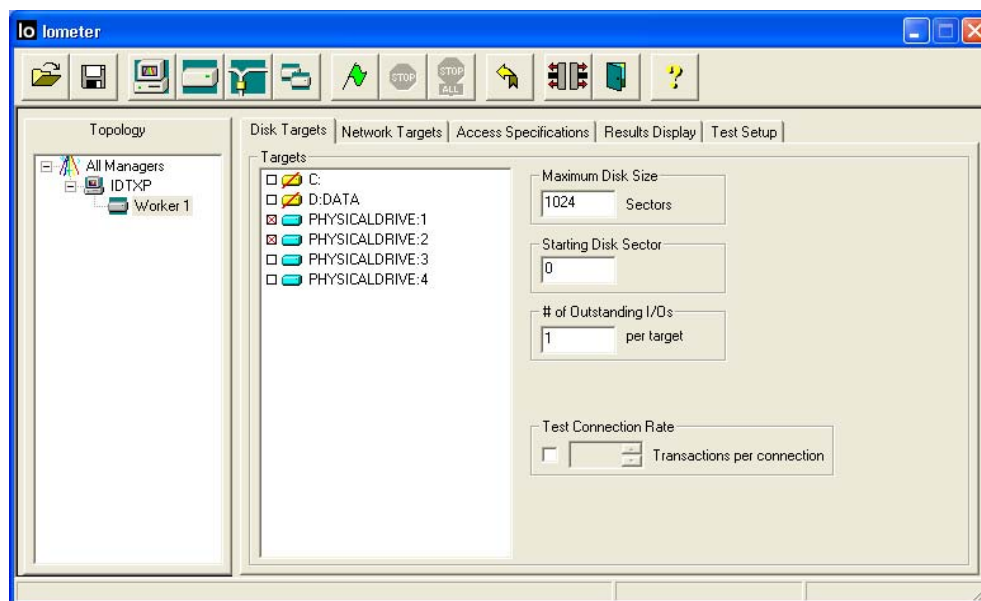

Figure 9 Iometer Disk Target Selection Screen

4. Under the Access Specifications Tab, have the worker perform a 128 KB Sequential Read (see Figure 10).



Notes

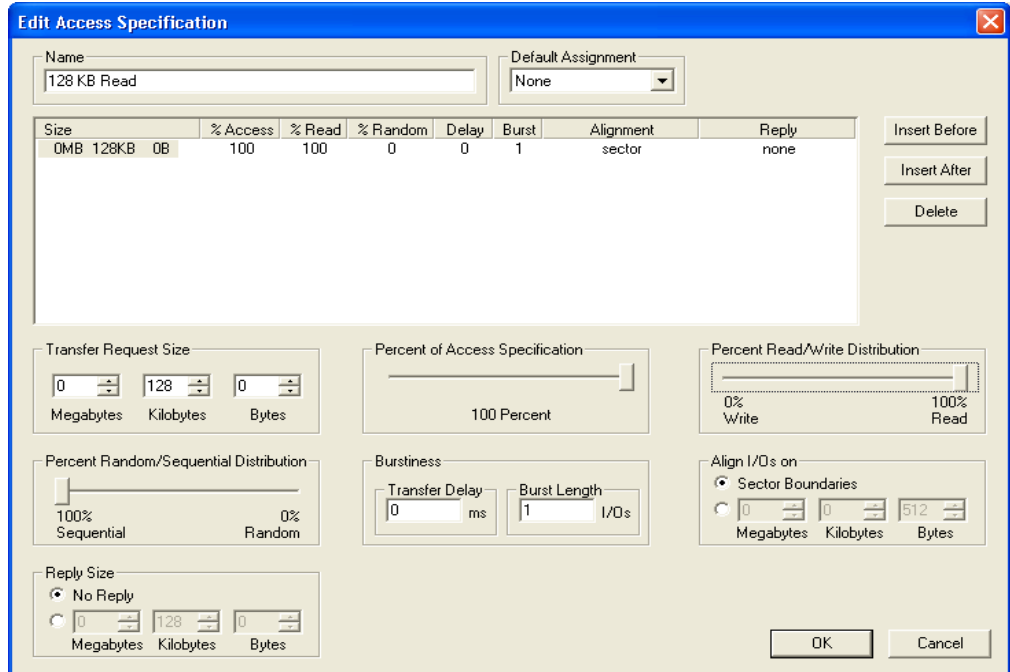

Figure 10 Iometer Access Specification Screen

- Once the Iometer is running, observe Link Utilization using the LeCroy PETracer. It should be a consistent 35% - 40% for both upstream and downstream traffic (as viewed by the upstream port of the Switch Evaluation Board). This is illustrated in Figure 11.

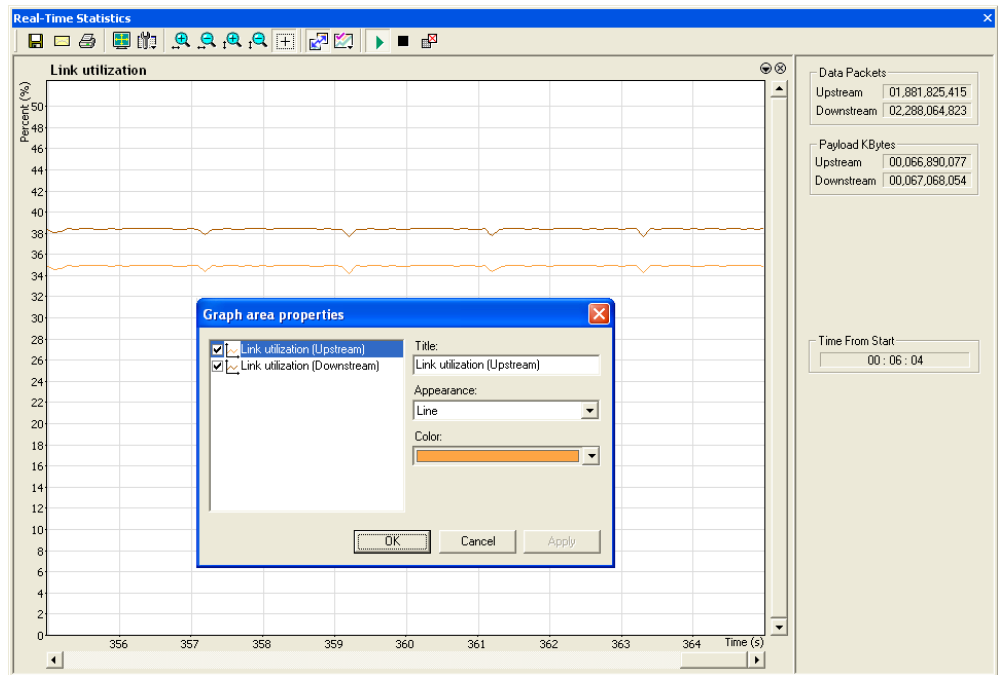

Figure 11 LeCroy PETracer Real-Time Statistics Screen

## Notes

6. If the Link Utilization is below 35% or above 40% with this setup, adjust the lometer settings. For example, adjust the access specification transfer request size until the Bidirectional Link Utilization on the upstream port of the Switch Evaluation Board is in the 35% to 40% range.

**Maximum Link Utilization Case**

Maximum power is measured under the following conditions: 70°C Ambient, 85% total link usage on the upstream port.

1. If the HPFC Cards are setup properly, when the lometer is opened it should display several physical volumes in addition to whatever Hard Disks are physically present in the system (see Figure 9). If the physical volumes that represent the HPFC Cards are not displayed, go into the disk manager and delete any partitions that may be present on these physical drives.
2. In the lometer window, assign a worker to all of the visible physical volumes.
3. Have the worker perform either a 1 MB Sequential Read or a 1 MB Sequential Write, whichever yields higher performance (varies slightly between the Switch Evaluation Boards).
4. Give two I/Os to the worker.
5. Duplicate the worker, creating two identical workers.
6. Once the lometer is running, observe Link Utilization using the LeCroy PETracer. It should be a consistent 80 - 90% for both upstream and downstream traffic.

## IMPORTANT NOTICE AND DISCLAIMER

RENESAS ELECTRONICS CORPORATION AND ITS SUBSIDIARIES (“RENESAS”) PROVIDES TECHNICAL SPECIFICATIONS AND RELIABILITY DATA (INCLUDING DATASHEETS), DESIGN RESOURCES (INCLUDING REFERENCE DESIGNS), APPLICATION OR OTHER DESIGN ADVICE, WEB TOOLS, SAFETY INFORMATION, AND OTHER RESOURCES “AS IS” AND WITH ALL FAULTS, AND DISCLAIMS ALL WARRANTIES, EXPRESS OR IMPLIED, INCLUDING, WITHOUT LIMITATION, ANY IMPLIED WARRANTIES OF MERCHANTABILITY, FITNESS FOR A PARTICULAR PURPOSE, OR NON-INFRINGEMENT OF THIRD PARTY INTELLECTUAL PROPERTY RIGHTS.

These resources are intended for developers skilled in the art designing with Renesas products. You are solely responsible for (1) selecting the appropriate products for your application, (2) designing, validating, and testing your application, and (3) ensuring your application meets applicable standards, and any other safety, security, or other requirements. These resources are subject to change without notice. Renesas grants you permission to use these resources only for development of an application that uses Renesas products. Other reproduction or use of these resources is strictly prohibited. No license is granted to any other Renesas intellectual property or to any third party intellectual property. Renesas disclaims responsibility for, and you will fully indemnify Renesas and its representatives against, any claims, damages, costs, losses, or liabilities arising out of your use of these resources. Renesas' products are provided only subject to Renesas' Terms and Conditions of Sale or other applicable terms agreed to in writing. No use of any Renesas resources expands or otherwise alters any applicable warranties or warranty disclaimers for these products.

(Disclaimer Rev.1.0 Mar 2020)

### Corporate Headquarters

TOYOSU FORESIA, 3-2-24 Toyosu,  
Koto-ku, Tokyo 135-0061, Japan  
[www.renesas.com](http://www.renesas.com)

### Contact Information

For further information on a product, technology, the most up-to-date version of a document, or your nearest sales office, please visit:  
[www.renesas.com/contact/](http://www.renesas.com/contact/)

### Trademarks

Renesas and the Renesas logo are trademarks of Renesas Electronics Corporation. All trademarks and registered trademarks are the property of their respective owners.