

Introduction

Electronic designs often involve switching power to a load. It is important to control the rate of switching in order to control the rate of rise of voltage and current (dV/dt and dI/dt) at the switching node. Excessive dV/dt and dI/dt can cause a power supply to droop, couple noise to nearby circuits, or cause transients which can be potentially harmful.

Motors can be especially problematic to switch. Motors can be roughly modeled as the inductance of the stator. If a motor's source power is switched on too quickly, an inductor resists a rapid change in current by producing back-EMF, following the inductor's constitutive equation, $V = L * dI/dt$. This results in a potentially harmful voltage transient at the switching node.

Furthermore, the inrush current will be large because as the motor starts from a standstill, the rotor is not moving, thereby not creating a back-EMF to resist current flow. As such, the inrush current will be large and similar to the stall current.

In this app note, we will evaluate two high-side switching methods: a relay for "instantaneous" switching, and the SLG59H1012V High Voltage GreenFET which has a programmable output dV/dt .

Test Set-up and Methodology

A relay and an High Voltage GreenFET are used in a similar manner as depicted in Figure 1.

The relay is energized from PSU #2 so that the activation of the coil is independent of the circuit being controlled. A 22uF capacitor and 3.9kOhm resistor are placed on the output of the relay circuit to snub noise, and more importantly, to be similar to the High Voltage GreenFET evaluation board.

A 1N4148 diode is placed in anti-parallel with the load to clamp the voltage induced when the supply is turned off.

A low-side current meter, powered by PSU #2, has a transconductance of 4.69 V/A, a bandwidth of 2MHz, a resistance of 0.01 Ohms, and an offset of 200mV. It is denoted with the standard symbol circled "A". Its output is connected to **channel 1** of the oscilloscope.

A simple voltage follower, powered by PSU #2, has an input resistance of 5MΩ. Its output is connected to **channel 2** of the oscilloscope. This output is used to showcase any noise coupling that may occur.

Channel 3 and 4 of the oscilloscope are connected to the input voltage and the switched voltage, respectively.

The input voltage consists of a 5V DC input from PSU #1 with an RC filter with 1Ω of series resistance and a 22μF electrolytic capacitor. This is to simulate a limited current/bandwidth power supply to allow the supply to droop in the event of a transient.

The load, a motor, is connected via 1 meter twisted pair wiring. It is placed far away from the rest of the set-up so that the EM fields the motor creates will minimally affect the circuitry. Thus, any noise we see due to the motor can be attributed to the interconnections and not EM propagation.

Two different motors will be evaluated. A 5V vibration motor, **ZJQ24-35F580C**, and a basic 5V motor found at Radioshack.

There is little difference between the two setups—the High Voltage GreenFET simply takes the place of the relay.

The testing methodology will be to switch each motor with each switching device. We will evaluate the power supply droop (Ch 3), switching node transients (Ch 4), inrush-current (Ch 1), and noise coupling to external circuitry (Ch 2).

More information, how the oscilloscope probes are connected, and photographs regarding the setup can be found in the Appendix.

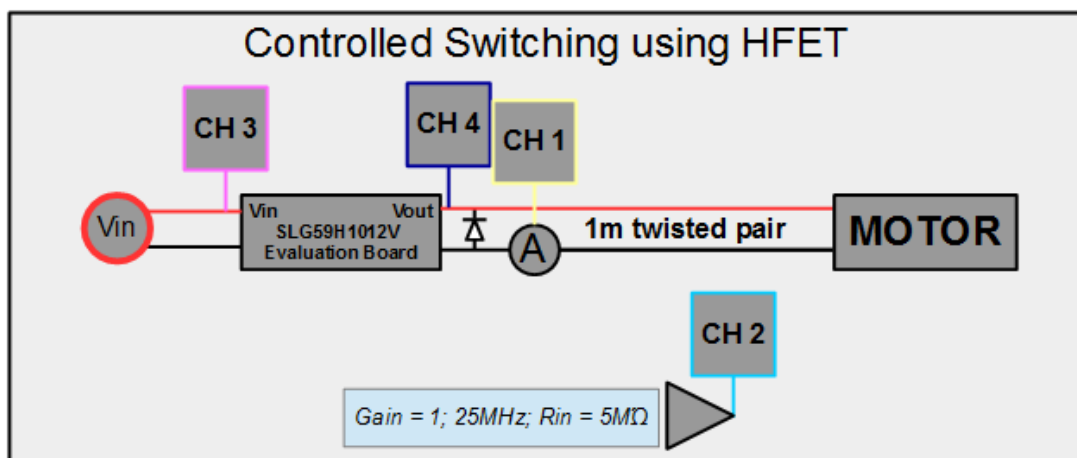
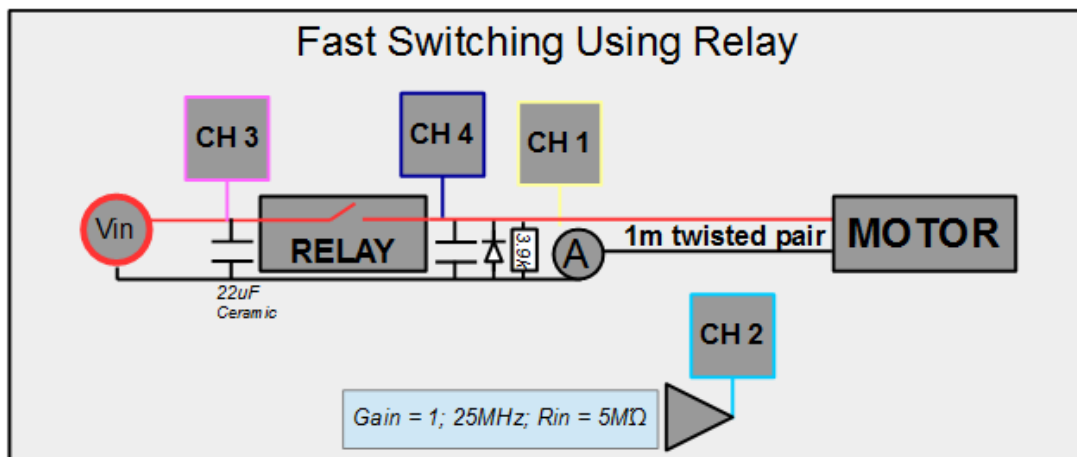
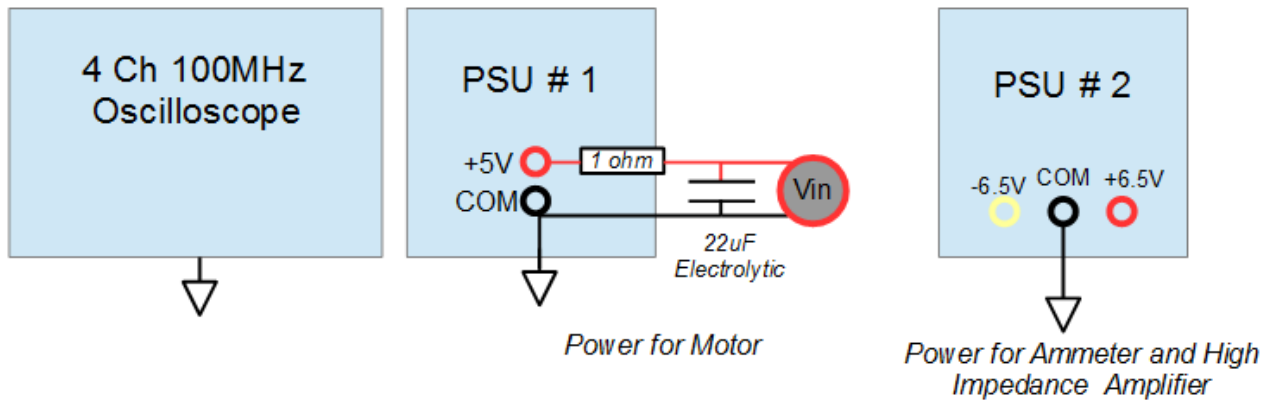

Figure 1. Test Setup

Channel	Color	Probe is measuring
Ch 1	Yellow	Current
Ch 2	Light Blue	Coupled Noise
Ch 3	Magenta	Vin
Ch 4	Dark Blue	Switching Node

Table 1. Probe Connections

Test Switching using a Relay

Figure 2 and Figure 3 display the turn-on behavior of the vibration motor when quickly turned on.

In Figure 2, we notice the input voltage drop by over 50% and oscillate as it recovers.

The initial drop is attributed to the charge equalization caused by “instantaneously” switching the additional capacitance and the inductance of the relay and interconnections being unable to immediately provide current to the capacitance/load. Also present are oscillations due to the resultant tank circuit.

High current exists due to the two capacitors equalizing, and high voltage is created due to the inductance of the relay, which results in a large amount of noise being coupled to the external circuit (more than 300mVpp).

We can also see that the current slowly ramps in this motor. Either the motor construction or internal circuitry is dampening the inrush.

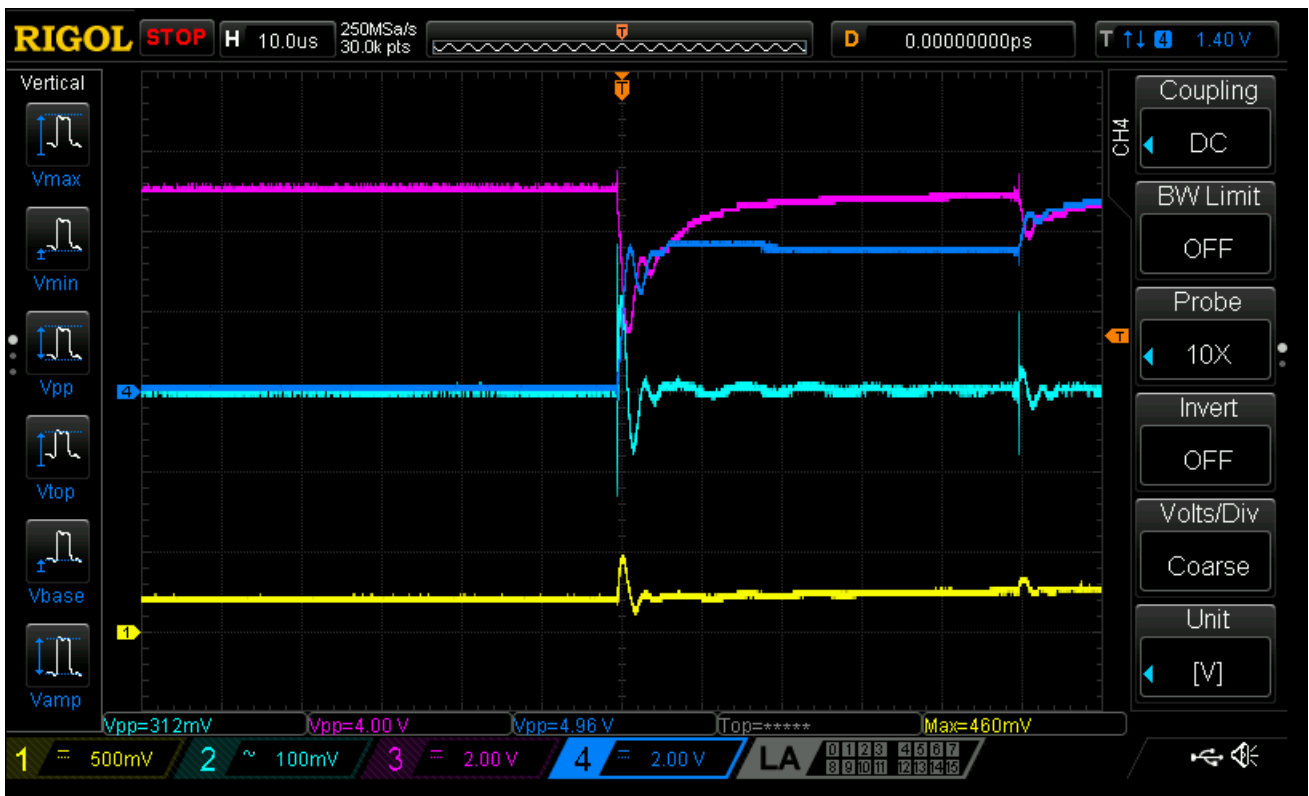

Figure 2. Turn on of Vibration Motor using Relay (10uS/div)

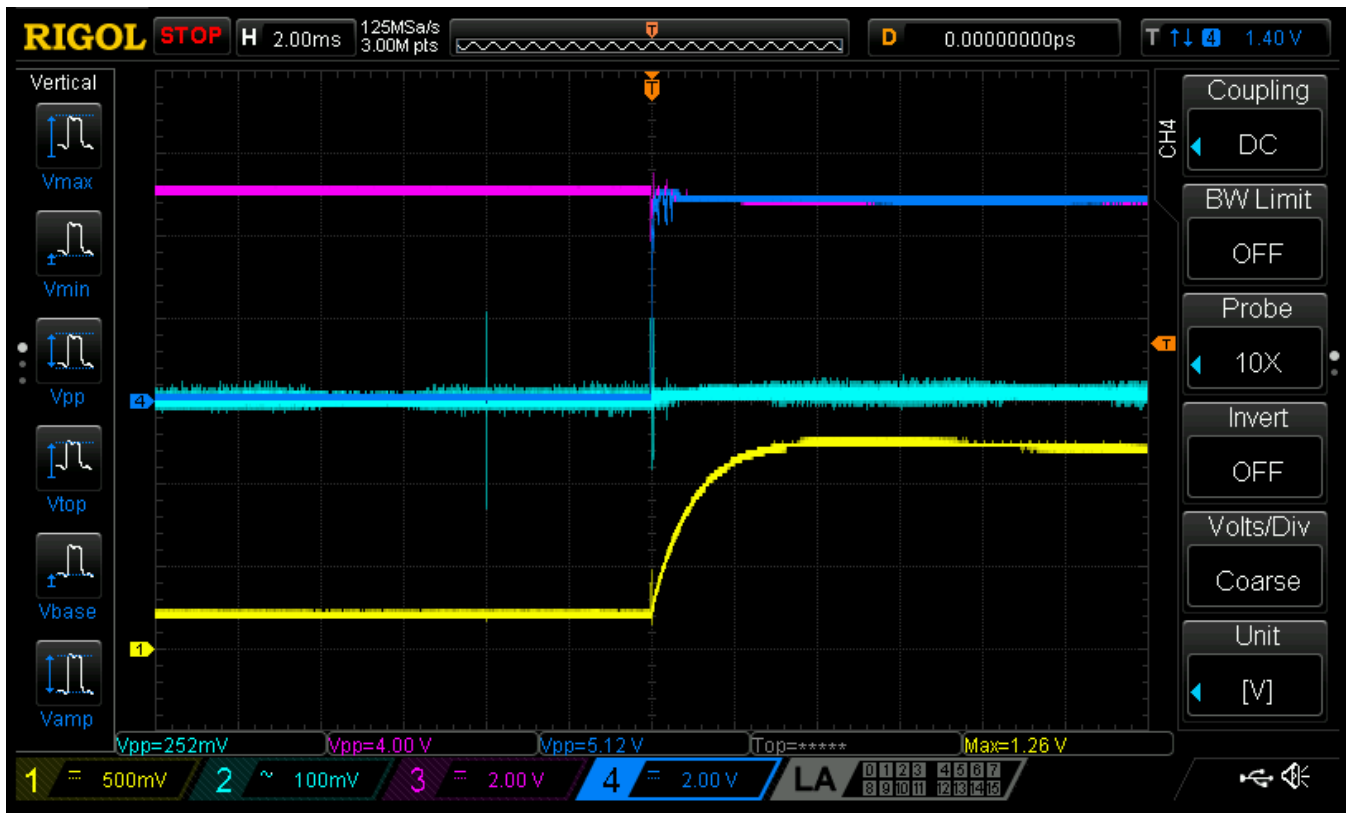

Figure 3. Turn on of Vibration Motor using Relay (2mS/div)

We see this switching method causes high-frequency voltage transients to appear on the power supply, the switching node, and the external amplifier. These frequencies appear to be around 100MHz, though there are likely higher-frequency components that the 100MHz oscilloscope cannot capture.

At these frequencies, ferrite beads are one of the only options for filtering, since most semiconductor devices have minimal rejection at such high frequencies. Furthermore, impeccable layout is needed to prevent these frequencies from coupling to circuitry before reaching the filter.

The power supply droop is dramatic but very brief. Additional capacitance or filtering at the point-of-load of other loads is required to prevent a glitch on, for example, a digital input IC.

The upside is that since it is such a fast transient, trace inductance and decoupling capacitors may be enough to dampen this effect enough to prevent erroneous operation.

RadioShack Motor

Figure 4 and Figure 5 show the turn on of the other motor.

Figure 4 shows that this motor has similar effects to the vibration motor with regard to the first few microseconds: a large spike on all voltages. We notice the output voltage stuttering as the motor totally discharges the output capacitance numerous times. The current measurement flies off-screen as we try to supply the large inrush-current.

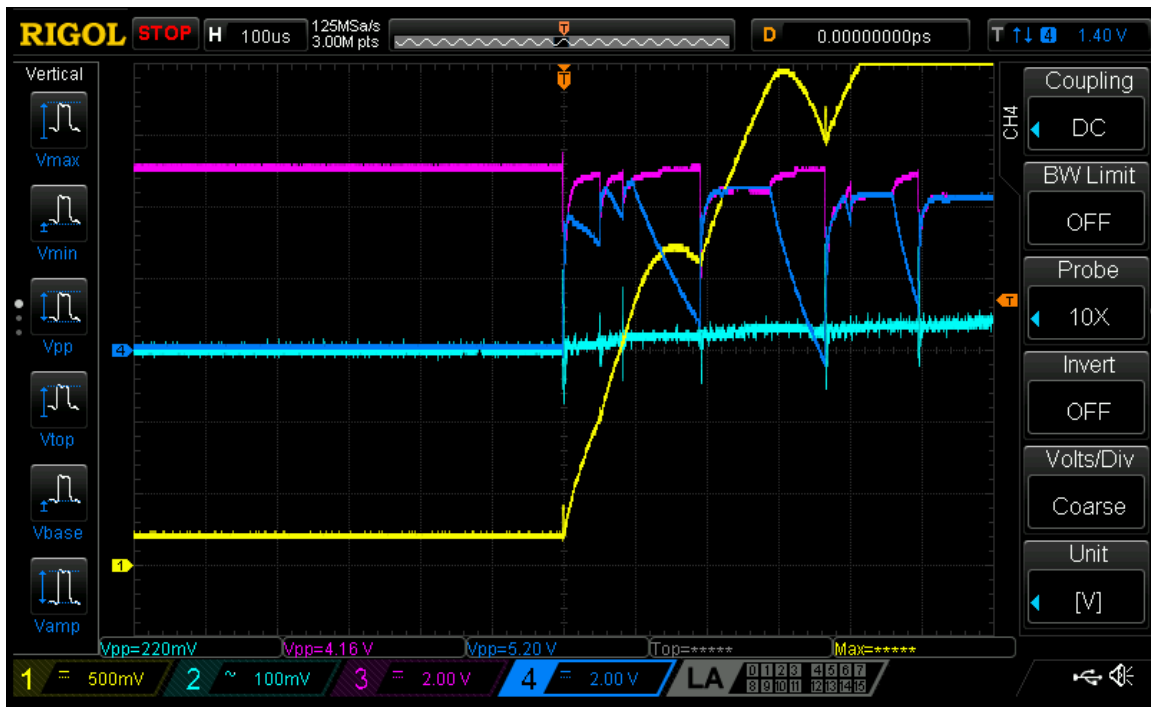

Figure 4. Turn on of DC motor using Relay (100µs/div)

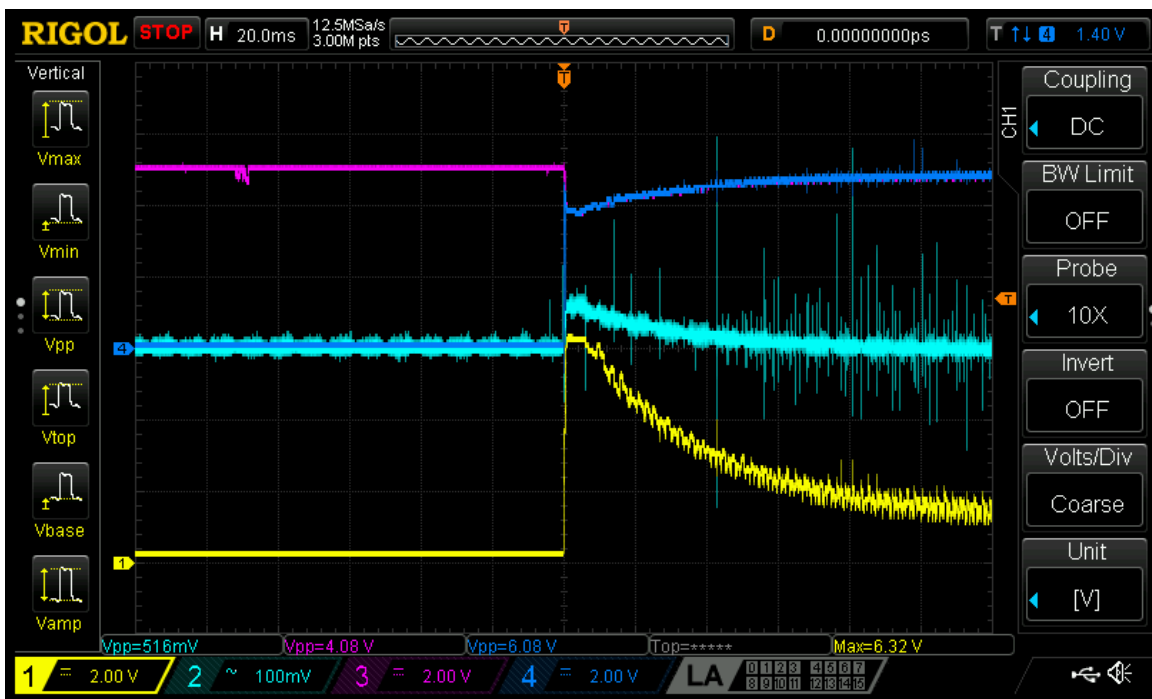

Figure 5. Turn on of DC motor using Relay (20ms/div); Ch 1 scale change to 2V/div

Figure 5 increases the timebase as well as the current scale. The current amplifier saturates at around 1.3A and the peak is likely just slightly higher. We see the stuttering stop as the motor spins up and draws less current.

This motor causes more problems than the first one. This time, the droop on the input voltage is due to the large currents being drawn. Aside from the voltage drop across our source resistance, this could cause a supply to current-limit. The amplitude of the oscillations on the power input are larger and of a longer duration (around 100ms) before reaching steady-state current.

This will be a more challenging filtering problem.

The motor is incredibly noisy as it spins, but that is beyond the scope of this discussion.

Controlled Switching using High Voltage GreenFET SLG59H1012V

Again, the oscilloscope traces are as follows:

Channel	Color	Probe is measuring
Ch 1	Yellow	Current
Ch 2	Light Blue	Coupled Noise
Ch 3	Magenta	V _{in}
Ch 4	Dark Blue	Switching Node

Table 2. Probe Connections

Next, we will see what improvements can be made with the SLG59H1012V. Among its features are a capacitor controlled slew rate and a current-limit. The evaluation board is modified for a 100k RSET resistor, setting the current-limit to just under 1 Ampere.

Vibration Motor

We saw earlier that this motor had some voltage transients during fast turn-on.

Figure 7 shows the turn-on of the vibration motor using the SLG59H1012V evaluation board. It has a C_SLEW of 10nF. Equation 1, found in the datasheet, solves to a rise-time of about 1.5ms.

$$C_{SLEW} = \frac{T_{RAMP}}{V_{IN}} \times 4.9 \mu A \times \frac{20}{3}$$

Equation 1. Slew rate

The SLG59H1012V shows an obvious improvement. There is no fast switching transient, no droop on the power supply, and no noise coupled onto the external circuit. The voltage rises as expected, in about 1.5ms and the current rises monotonically. This switching method has avoided all the previously outlined problems caused by the fast switching.

This controlled voltage rise prevents the spikes caused by induced currents and voltages that were present due to the cable parasitics and motor inductance and load. Instead, that energy is consumed by the High Voltage GreenFET during the transition.

Radioshack Motor

This motor had the same fast turn-on problems as the vibration motor, with the added downfall of the large inrush-current. By changing the C_SLEW to 1uF, the rise time is further slowed-down. Equation 1, above, solves to a rise-time of 150ms.

Figure 7 below, shows the result:

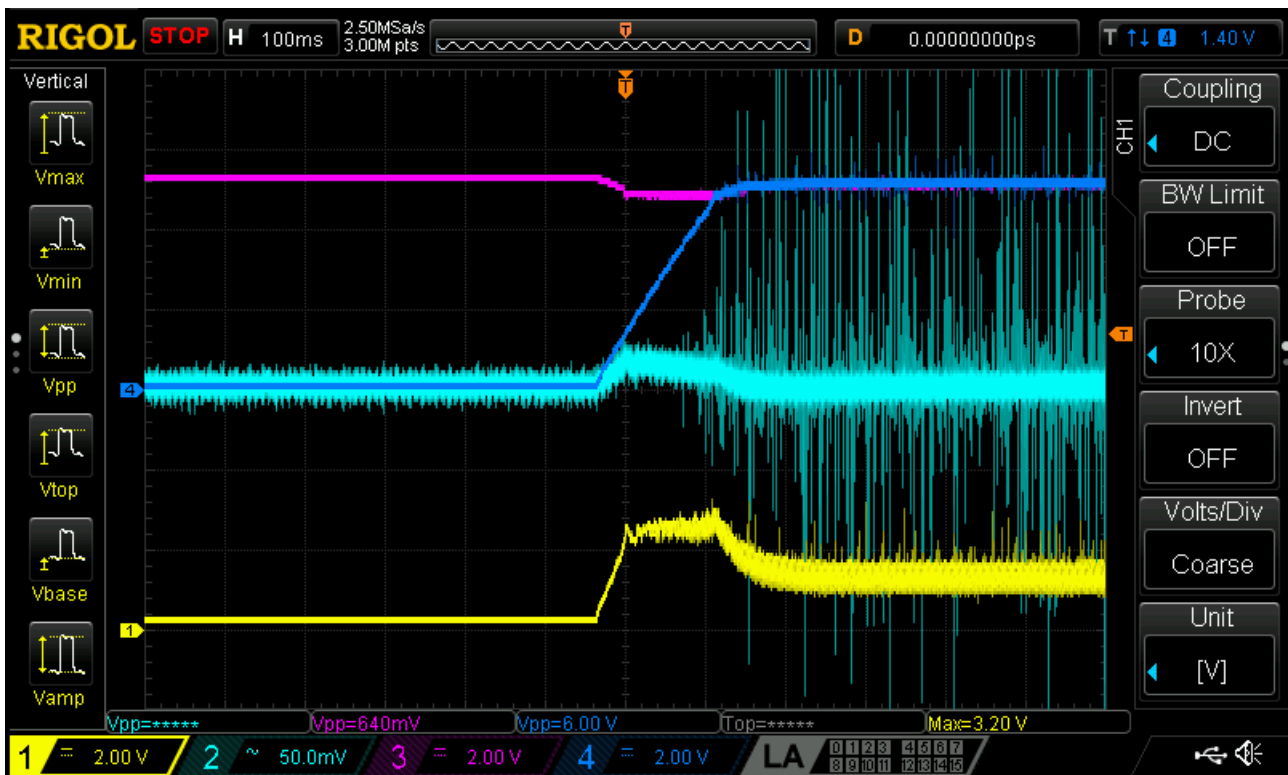

Figure 7. Turn on of Vibration Motor using SLG59H1012V (100ms/div). Ch 1 scale 2V/div

As expected, the output voltage slews in about 150ms.

Just like in the vibration motor, the rapid switching transients are not present.

This motor had the issue of 1.2+ Amperes of inrush current. This time, the current amplifier does not saturate and we see a peak current of about 650mA—a great improvement. This is due to the slowly slewing output voltage. By turning on the resting motor slowly, the stall-current is lowered and by the time the output voltage is reached the motor has already begun spinning.

The input voltage still droops due to the relatively large 1Ω impedance. A typical power supply will have much lower impedance but perhaps a similar bandwidth and current-limit.

This switching method will prevent the input supply from drooping excessively as long as it has a bandwidth greater than a few Hertz and a reasonably low source impedance.

Again, this exceedingly noisy motor causes spikes to couple everywhere once it is turned on.

As far as the turn-on issues are concerned, using the SLG59H1012V to control the slew of the output has improved the transient issues that were present with fast-switching.

Conclusion

Fast switching can cause power supply droop as well as noise-coupling. This is especially true for motor control, where large inductances exist and a high inrush-current may be present.

We were able to prevent power-supply droop and transient noise coupling using the SLG59H1012V and its capacitor programmable output slew control. The back-EMF caused by rapidly switching an inductance is greatly minimized such that it is negligible and the inrush-current is reduced to manageable levels.

Appendix 1: Photographs of the Setup

All measurements were taken with short-loops for higher fidelity measurement. These can be seen in some pictures, below. Alligator clips and banana jacks are used for most of the interconnections.

In Fig 1.1, the amplifier circuit connects by twisted pair to partially seen PSU #2. Notice the small loop used for measurement.

In Fig 1.2, the power input is on the left and the wires leading to the energizing circuit is from top. The switch is used to energize the relay. The back-side of the board contains the diode, capacitors, and interconnects. The tabs are used to connect to the circuit using alligator clips.

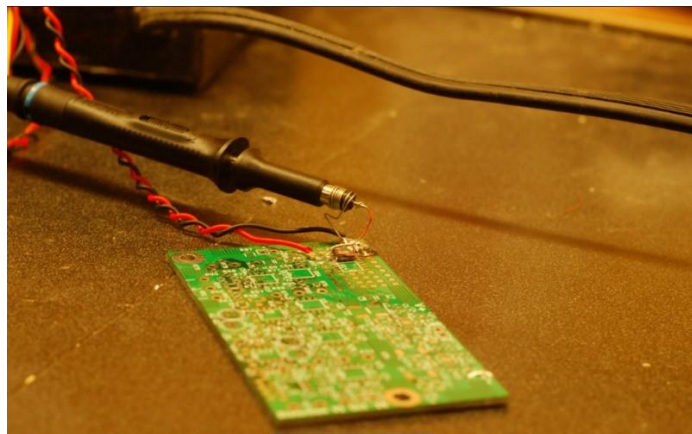

Figure 1.1. External Amplifier Circuit

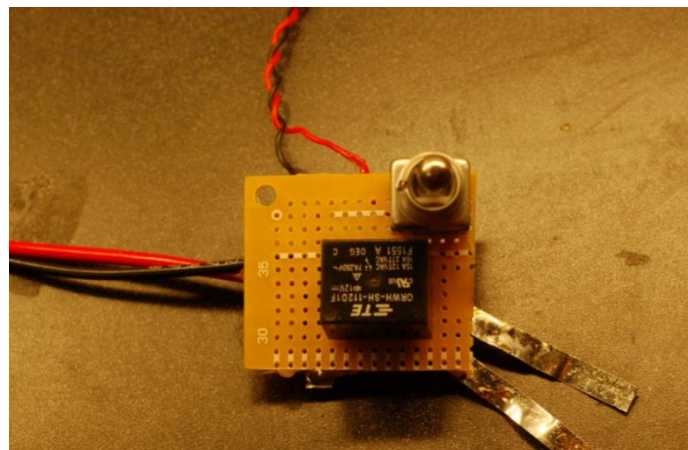

Figure 1.2. Relay Circuit

In Fig 1.3, the PSU on the left is PSU #1 and the PSU on the right is PSU #2. Both are floating supplies. Earth grounding occurs through the oscilloscope probes, which are connected with small loops soldered directly to a nearby ground. The probe tip is placed in a drilled hole or a small loop of wire to hold it.

The motor (not shown), is connected to the red/black twisted pair leaving the bottom of the photo. The relay circuit is the yellow one on its side. The current meter is the circuit in Figure 1.4, and the external amplifier is the circuit on the right.

The inputs are screwed on. The oscilloscope probe ground is screwed down and the tip is jammed into the other screw connector.

The motor and current meter connect with alligator clips.

These motors were interconnected with 1m of twisted pair wiring and placed 1m away.

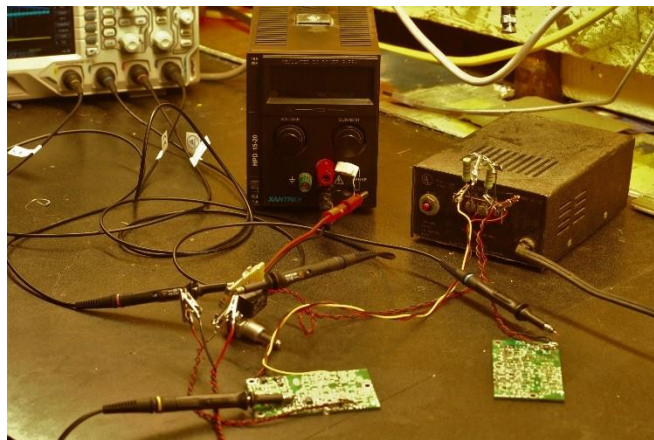

Figure 1.3. Fast Switching Setup

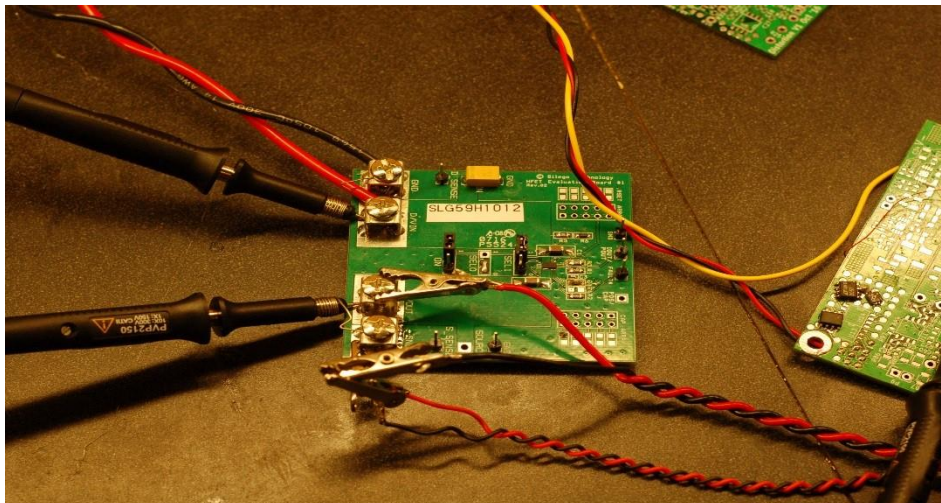

Figure 1.4. SLG59H1012V Development Board



Figure 1.5. Vibration motor in a vise



Figure 1.6. DC Motor from Radioshack

IMPORTANT NOTICE AND DISCLAIMER

RENESAS ELECTRONICS CORPORATION AND ITS SUBSIDIARIES (“RENESAS”) PROVIDES TECHNICAL SPECIFICATIONS AND RELIABILITY DATA (INCLUDING DATASHEETS), DESIGN RESOURCES (INCLUDING REFERENCE DESIGNS), APPLICATION OR OTHER DESIGN ADVICE, WEB TOOLS, SAFETY INFORMATION, AND OTHER RESOURCES “AS IS” AND WITH ALL FAULTS, AND DISCLAIMS ALL WARRANTIES, EXPRESS OR IMPLIED, INCLUDING, WITHOUT LIMITATION, ANY IMPLIED WARRANTIES OF MERCHANTABILITY, FITNESS FOR A PARTICULAR PURPOSE, OR NON-INFRINGEMENT OF THIRD PARTY INTELLECTUAL PROPERTY RIGHTS.

These resources are intended for developers skilled in the art designing with Renesas products. You are solely responsible for (1) selecting the appropriate products for your application, (2) designing, validating, and testing your application, and (3) ensuring your application meets applicable standards, and any other safety, security, or other requirements. These resources are subject to change without notice. Renesas grants you permission to use these resources only for development of an application that uses Renesas products. Other reproduction or use of these resources is strictly prohibited. No license is granted to any other Renesas intellectual property or to any third party intellectual property. Renesas disclaims responsibility for, and you will fully indemnify Renesas and its representatives against, any claims, damages, costs, losses, or liabilities arising out of your use of these resources. Renesas' products are provided only subject to Renesas' Terms and Conditions of Sale or other applicable terms agreed to in writing. No use of any Renesas resources expands or otherwise alters any applicable warranties or warranty disclaimers for these products.

(Rev.1.0 Mar 2020)

Corporate Headquarters

TOYOSU FORESIA, 3-2-24 Toyosu,
Koto-ku, Tokyo 135-0061, Japan
www.renesas.com

Contact Information

For further information on a product, technology, the most up-to-date version of a document, or your nearest sales office, please visit:
www.renesas.com/contact/

Trademarks

Renesas and the Renesas logo are trademarks of Renesas Electronics Corporation. All trademarks and registered trademarks are the property of their respective owners.