

LED Flashlight Mode Controller using Asynchronous State Machine

SLG46537

The application note gives step-by-step guidelines for creating an LED flashlight mode controller using Asynchronous State Machine design using a SLG46537V device. A unique set of components of the SLG46537 allows the creation of such a system.

The application note comes complete with design files which can be found in the Reference section.

Contents

- 1. **Terms and Definitions** 2
- 2. **References** 2
- 3. **Introduction** 2
- 4. **General Operating Principle** 2
- 5. **Single Button Selector** 2
- 6. **30% Light Brightness Generation** 3
- 7. **70% Light Brightness Generation** 3
- 8. **100% Light Brightness Generation** 3
- 9. **“SOS” Signal Generation** 3
- 10. **Battery Discharge Control** 4
- 11. **Current Limit Function** 4
- 12. **Conclusion** 5
- 13. **Revision History** 6

Figures

- Figure 1. ASM state diagram design4
- Figure 2. LED headlight circuit design5
- Figure 3. Flashlight circuit5

1. Terms and Definitions

ACMP	Analog Comparator
ASM	Asynchronous State Machine
CTN	Counter
DFF	D-Flip Flop
DLY	Delay
LED	Light Emitting Diode
LUT	Look-Up Table
PWM	Pulse Width Modulation

2. References

For related documents and software, please visit:

[GreenPAK Programmable Mixed-Signal Products | Renesas](#)

Download our free GreenPAK Designer software [1] to open the .gp5 files [2] and view the proposed circuit design. Use the GreenPAK development tools [3] to freeze the design into your own customized IC in a matter of minutes. Renesas provides a complete library of application notes [4] featuring design examples as well as explanations of features and blocks within the Renesas IC.

[1] [GreenPAK Designer Software](#), Software Download and User Guide, Renesas Electronics

[2] [AN-1087 LED Flashlight Mode Controller using Asynchronous State Machine.gp](#), GreenPAK Design File, Renesas Electronics

[3] [GreenPAK Development Tools](#), GreenPAK Development Tools Webpage, Renesas Electronics

[4] [Application Notes](#), GreenPAK Application Notes Library, Renesas Electronics

3. Introduction

This application note demonstrates how to design with the asynchronous state machine within the SLG46537 GreenPAK IC. This design controls an LED flashlight and features numerous modes all controlled by a single button.

4. General Operating Principle

The five operating modes are: disabled mode, low brightness (PWM with 30% duty cycle), moderate brightness (PWM with 70% duty cycle), maximum brightness (PWM with 100% duty cycle) and SOS signal mode (dots are 100ms, dashes are 300ms, pauses between dots and dashes are 100ms, pauses between characters are 300ms, and pauses between words are 700ms). This design also has a built-in detector which monitors battery discharge level in all modes except disabled mode.

5. Single Button Selector

There are considerations to properly create the asynchronous state machine input signaling so that we switch only one state, with no influence on the other states. The approach presented gives guaranteed results with input signal processing of the single button selector.

The single button selector is first a frequency divider (realized using a D flip-flop), rising edge detector and falling edge detector in order to separate signals for states switching. Its operation principles are as follows.

After the button is pressed the DFF1 switches to the LOW state and a rising edge appears at the output. After that a single pulse is created at the EDGE DET0 output that switches the Asynchronous State Machine (ASM) from «OFF» disabled mode to the "30% PWM" state (moderate brightness mode).

6. 30% Light Brightness Generation

In the state of "30% PWM", the RAM3 output goes HIGH, RAM4 output goes LOW, and these signals come to the IN2 and IN3 inputs of the 4-bit LUT0. IN1 receives a signal from CNT1 block with 70% duty cycle. From the 4-bit LUT0 output a signal with 70% duty cycle appears on the output PINs, configured as the NMOS open drain. The LED illuminates when the output is LOW, and off when output is HIGH.

After the next button press, DFF1 goes LOW and the detector's output pulse appears, which switches the ASM from "30% PWM" to "70% PWM" state.

7. 70% Light Brightness Generation

In the state of "70% PWM", the RAM3 output goes LOW, RAM4 output goes HIGH and these signals come to the IN2 and IN3 inputs of the 4-bit LUT0. IN1 receives a signal from CNT1 block with 70% duty cycle.

From the 4-bit LUT0 output the signal, which, being inverted, now has 30% duty cycle comes to the output PINs, configured as NMOS open drain.

After the next button press, DFF1 goes HIGH and the detector's output pulse appears, which switches the ASM from "70% PWM" to "100% PWM" state.

8. 100% Light Brightness Generation

In the state of "100% PWM" the RAM3 output goes HIGH, RAM4 output goes LOW, RAM0 goes HIGH and these signals come to the IN3, IN2 inputs of 4-bit LUT0 and "Reset IN" input of CNT1 respectively. Because of that IN1 receives a LOW level signal from CNT1 block. The 4-bit LUT0 output LOW level signal appears at the output PINs.

After the next button press, DFF1 goes LOW, and the detector's output pulse appears, that switches the ASM from "100% PWM" to "SOS signal" state.

9. "SOS" Signal Generation

For "SOS" signal generation, numerous on-chip resources are required: three Delay blocks, two DFFs, five LUTs, one Pipe Delay and three states of the ASM block.

After the "100% PWM" state, the ASM will be switched into «---» state of SOS signal mode that generates 700ms pause between repeating "SOS" words. After the DLY5 output goes HIGH, that switches the ASM from «---» into «S» state to generate the first letter "S" (three dots – Morse code).

It is generated by the DLY3 with negative feedback.

After three pulses ("S" letter), a transition into "O" state happens. Here the second letter – "O" (three dashes – Morse code) will be generated by the DLY4 with negative feedback and variable output pulses frequency (pulse width should be 300 ms and pause between pulses – 100 ms).

To do this a 3-bit LUT1 is used as a MUX for the signal with different frequencies, which can be supplied to DLY4 CLK input. This period consists of 3 dashes (300 ms each), 2 dash pauses (100 ms each), 2 letters pauses (300 ms each) and is equal to 1.7s. DLY6 calculates this time (1.7s), after that it generates a signal for transition into state "S2", where the third letter of the word "SOS" – "S" is generated, using the same blocks as for the first "S".

After the last "S" is generated, the signal, which switches ASM into «---» state (the pause between repeating "SOS" words) will be generated. This process repeats until the single button is once again pressed.

10. Battery Discharge Control

A Li-ion battery (18650 type) is used for this flashlight power supply. Operating range for this battery is 3.0V – 4.2V. To protect the battery from excessive discharge, two voltage levels are detected. The first is equal to 3.6V and if the voltage is lower, it is recommended to recharge it. If the voltage is lower than 3.6V, then in case the ON/OFF button is pressed, BAT LOW indicator LED on the flashlight body will illuminate.

The second level is 3.0V. If the voltage is lower, ACMP0 will generate a signal which resets the ASM, which will turn the LED to the OFF state (disabled mode). This helps to preserve the battery “health”, and also to retain the number of charge/discharge life cycles.

11. Current Limit Function

In this design, current limit and stabilization techniques are implemented to avoid LED overcurrent.

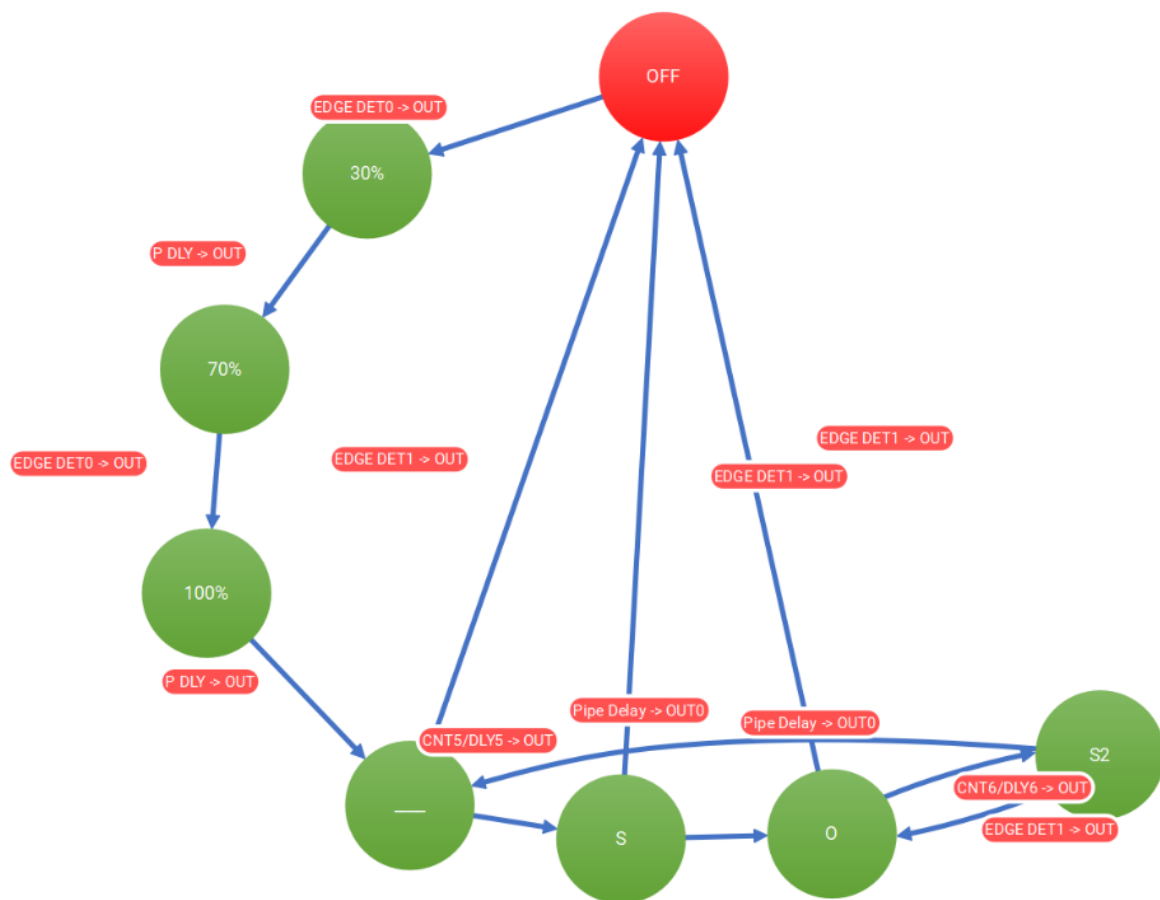

Figure 1. ASM state diagram design

This approach is more efficient compared to the classical scheme of current limit using a resistor. Also, it operates effectively over a wide VDD range. It is realized using internal ACMP2 and an external resistor. The current that flows through LED2 is equal to the current that flows through R3 resistor.

High level on ACMP2 output means that the current is greater than the given threshold and PMOS transistor T1 is OFF. When the level on ACMP2 is low, it means that the current level is normal and T1 is turned ON.

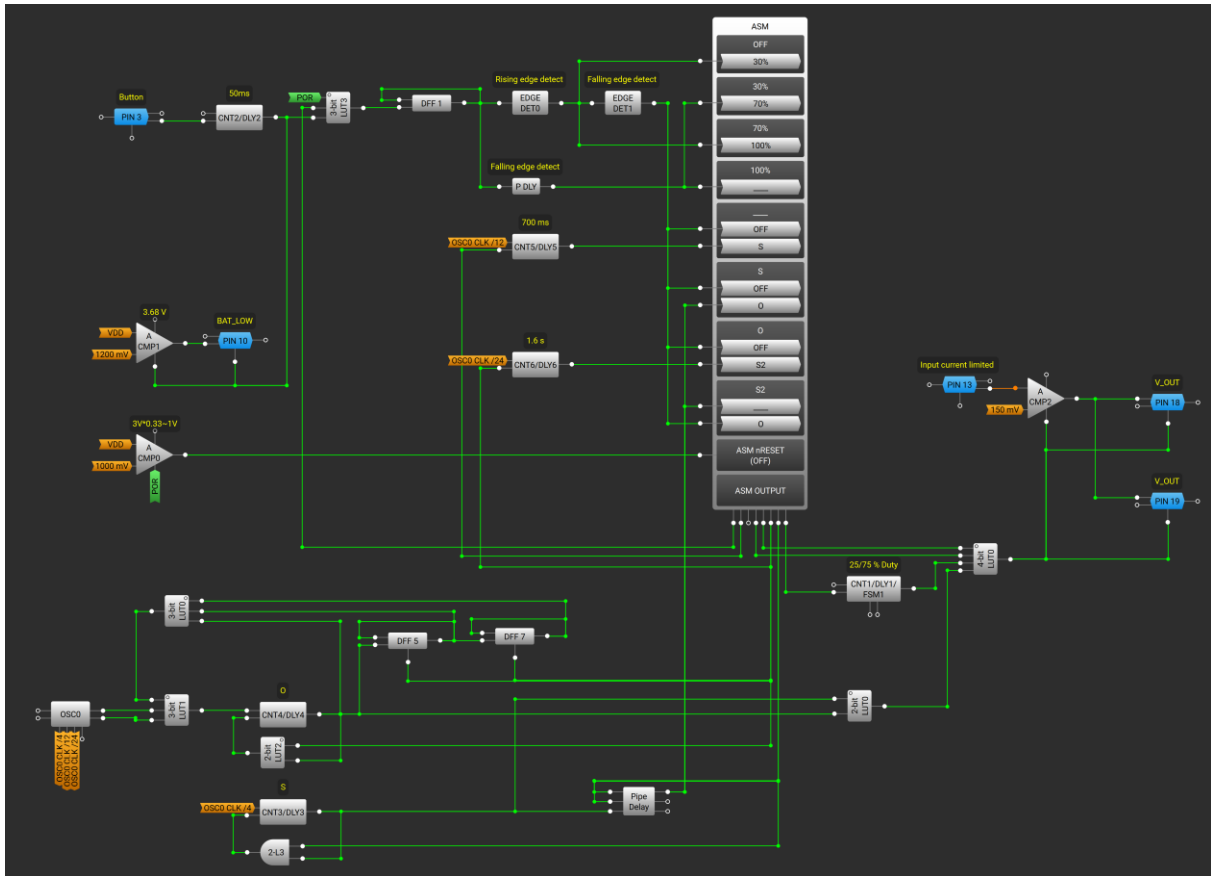

Figure 2. LED headlight circuit design

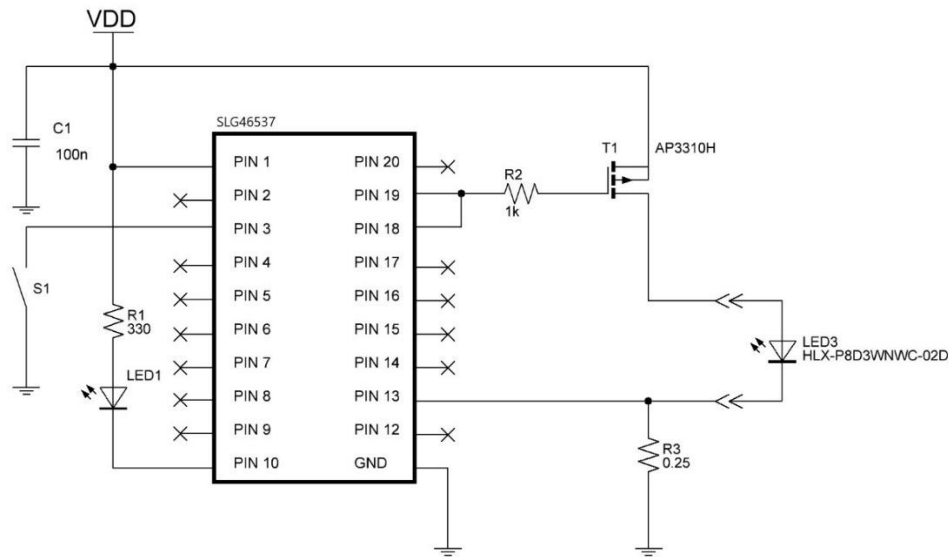

Figure 3. Flashlight circuit

12. Conclusion

This LED flashlight was quickly designed with within the GreenPAK asynchronous state machine, and is robust. Even with the numerous modes of operation, it features low power consumption and only a few external components.

13. Revision History

Revision	Date	Description
1.00	Oct 2, 2015	Initial release.
2.00	Apr 6, 2026	The part number has been changed from SLG46531V to SLG46537V.

IMPORTANT NOTICE AND DISCLAIMER

RENESAS ELECTRONICS CORPORATION AND ITS SUBSIDIARIES (“RENESAS”) PROVIDES TECHNICAL SPECIFICATIONS AND RELIABILITY DATA (INCLUDING DATASHEETS), DESIGN RESOURCES (INCLUDING REFERENCE DESIGNS), APPLICATION OR OTHER DESIGN ADVICE, WEB TOOLS, SAFETY INFORMATION, AND OTHER RESOURCES “AS IS” AND WITH ALL FAULTS, AND DISCLAIMS ALL WARRANTIES, EXPRESS OR IMPLIED, INCLUDING, WITHOUT LIMITATION, ANY IMPLIED WARRANTIES OF MERCHANTABILITY, FITNESS FOR A PARTICULAR PURPOSE, OR NON-INFRINGEMENT OF THIRD-PARTY INTELLECTUAL PROPERTY RIGHTS.

These resources are intended for developers who are designing with Renesas products. You are solely responsible for (1) selecting the appropriate products for your application, (2) designing, validating, and testing your application, and (3) ensuring your application meets applicable standards, and any other safety, security, or other requirements. These resources are subject to change without notice. Renesas grants you permission to use these resources only to develop an application that uses Renesas products. Other reproduction or use of these resources is strictly prohibited. No license is granted to any other Renesas intellectual property or to any third-party intellectual property. Renesas disclaims responsibility for, and you will fully indemnify Renesas and its representatives against, any claims, damages, costs, losses, or liabilities arising from your use of these resources. Renesas' products are provided only subject to Renesas' Terms and Conditions of Sale or other applicable terms agreed to in writing. No use of any Renesas resources expands or otherwise alters any applicable warranties or warranty disclaimers for these products.

(Disclaimer Rev.1.01)

Corporate Headquarters

TOYOSU FORESIA, 3-2-24 Toyosu,
Koto-ku, Tokyo 135-0061, Japan
www.renesas.com

Trademarks

Renesas and the Renesas logo are trademarks of Renesas Electronics Corporation. All trademarks and registered trademarks are the property of their respective owners.

Contact Information

For further information on a product, technology, the most up-to-date version of a document, or your nearest sales office, please visit www.renesas.com/contact-us/.