

Introduction

This Application Note is one of a series addressing different aspects of an emerging networking usage model for wireless infrastructure networking equipment: Low Time-Error nodes. The transmission of time / phase information over the wireless infrastructure network with minimal error from the Grand Master to every node in the network is becoming increasingly important for most network operators as they prepare their wireless infrastructure networks to support 5th Generation (5G) wireless protocols and beyond.

Please consult any or all of the following documents for a full picture:

- AN-1031 – Time Alignment Background in Wireless Infrastructure (this document)
 - Discusses the importance of time-alignment in wireless infrastructure networks and key topics at the network level. Describes the various classes of alignment discussed in ITU-T document.
- AN-1032 – Time-of-Day Transfer within an Ideal Chassis-Based System
 - Discusses topics related to how to move ToD information from a master timer to various slave timers within a typical wireless infrastructure networking system. This Application Note assumes an ideal system with no wiring or silicon propagation delays on any of the transmission paths. It is necessary to understand the flow of information needed and errors that can be introduced in reading out and loading ToD information into timers. Ensure this note is read and understood before AN-1033 is read.
- AN-1033 – Delay Variation Measurement & Compensation in Non-Ideal Chassis-Based Systems
 - Expands on the discussion in AN-1032 by adding propagation delay effects and how to counter them into the discussion. While using a chassis-based system as an example, single-board systems will experience the same issues and solutions, albeit to a much lesser degree.
- AN-1034 – Minimizing Backplane Signal Usage in Chassis-Based Systems implementing low-cTE Functions
 - This Application Note proposes a method to minimize the number of signal traces needed to transport the necessary information across a system backplane for transfer of accurate ToD from master timer to slave timers. This method allows existing backplanes to be used without extra traces being required. While the method herein could be used in single-board systems, it is not usually as important to limit the number of traces in such a system as it is in a chassis.
- AN-1035 – 8A340x1 ClockMatrix Device Internal Delays and Delay Variations for Compensation Calculations
 - Calculation of exact compensation values is described in AN-1033. This Application Note provides measured values for IDT's 8A340x1 devices for use in those calculations.

Some other related Application Notes that can be of interest are:

- AN-1010 – ClockMatrix Time-to-Digital Converter (TDC)
 - This Application Note describes how to use the TDC circuit in IDT's ClockMatrix family of devices as a precision phase measurement function. Includes details on setups using IDT's Timing Commander software.
- AN-1030 – Input/Input-to-Output/Output Phase Adjustments
 - This Application Note describes how phase relationships can be adjusted input-input, input-output and output-output within IDT's ClockMatrix family of devices. Includes details on setups using IDT's Timing Commander software.
- PWM User Guide
 - This User Guide describes how to use the Pulse-Width Modulation features of IDT's ClockMatrix family of products.
- AN-1036 Using GPIOs for Loading and Latching ToD in 8A3xxxx Devices
 - This Application Note describes the methods for Loading and Latching ToD counters using GPIO signals.

What is the Benefit of Tight Time Alignment in Wireless Base-Stations?

Cellular wireless networks are rapidly evolving in many ways, chief among them are the ability to precisely locate an endpoint device (e.g. handset, IoT terminal or autonomous vehicle) and the ability to transfer data faster. Both use cases can be advanced by achieving Time-of-Day (ToD) alignment between multiple base stations in the wireless network. Note that “Time-of-Day” in the context of a radio network refers to the time representation within that network and are not always accurate to a universal time source like UTC. It is the time that events occur in one radio relative to a common reference in the network and relative to another node in the same radio network.

Several wireless base-stations can be used together to triangulate the location of a single receiver. For a stationary object in an open area, the base-stations need only communicate the distance of the receiver from the base-station to a central compute function. That central compute function can establish the position once it knows the distance from 3 or more base-stations which own positions are known.

However, if the object is moving or in a congested area which can result in signal reflections (multi-path signals), it is necessary to know when a signal was received both to eliminate false paths and to establish a movement path and speed. The more accurate the time-stamps placed on the transactional information by each base-station, the more accurate the calculated position.

In the case of faster data rates, this is addressed in two ways: increasing probability of signal receipt and elimination of interference. If multiple wireless base-stations are aware of the position of a receiver relative to them, they can coordinate transmissions so that a signal from each base-station arrives at the receiver within a very tight time window. The more precisely the base-stations can synchronize their internal clocks, the tighter the time window they can achieve at the receiver. Receiving multiple signals within a short time window enhances the receiver’s ability to receive the signal. With enhanced reception probability, higher order modulations of the radio signals can be used to transmit more data per unit time (symbol), improving data transmission rate.

In terms of interference reduction, if each base-station is aware of the signal pattern of each neighboring base-station and especially of the time of transmission, that interference can be subtracted from a received signal to make the real signal more discernible. This interference cancellation becomes better with tighter time-of-day alignment between multiple base-stations.

One recent target for time error at radio transmitters and receivers publicly disclosed by network operators are:

- ± 390 nsec for any two radios in an entire network

How Do Base-Stations Establish and Maintain Alignment?

Actual base-station specifications established by 3GPP are about the phase alignment of radio signals. This can be established within each base-station as a Time-of-Day or as a phase alignment.

One method that has been used is to have a Global Navigation Satellite System (GNSS) receiver at each base-station. This works well if a receiver can view enough of the sky to be in contact with 4 of the (usually) 8 GNSS satellites that are above the visible horizon at any time. Base-stations so equipped can achieve an alignment of $\sim\pm 50\text{ns}$ under optimal conditions. Tighter alignments are possible, but only with more expensive techniques such as differential GNSS. Other issues with this method include interference in the satellite signals as well as Line-of-Sight issues that prevent sufficient view of the sky.

As shown in Figure 1, it is also possible to transmit time/phase information from a central time source in a network to all nodes in the network over the network inter-connect. This removes the Line-of-Sight and signal interference issues of GNSS but is subject to a great deal of both fixed and varying delays.

Figure 1. Transferring Time / Phase Information Across a Network

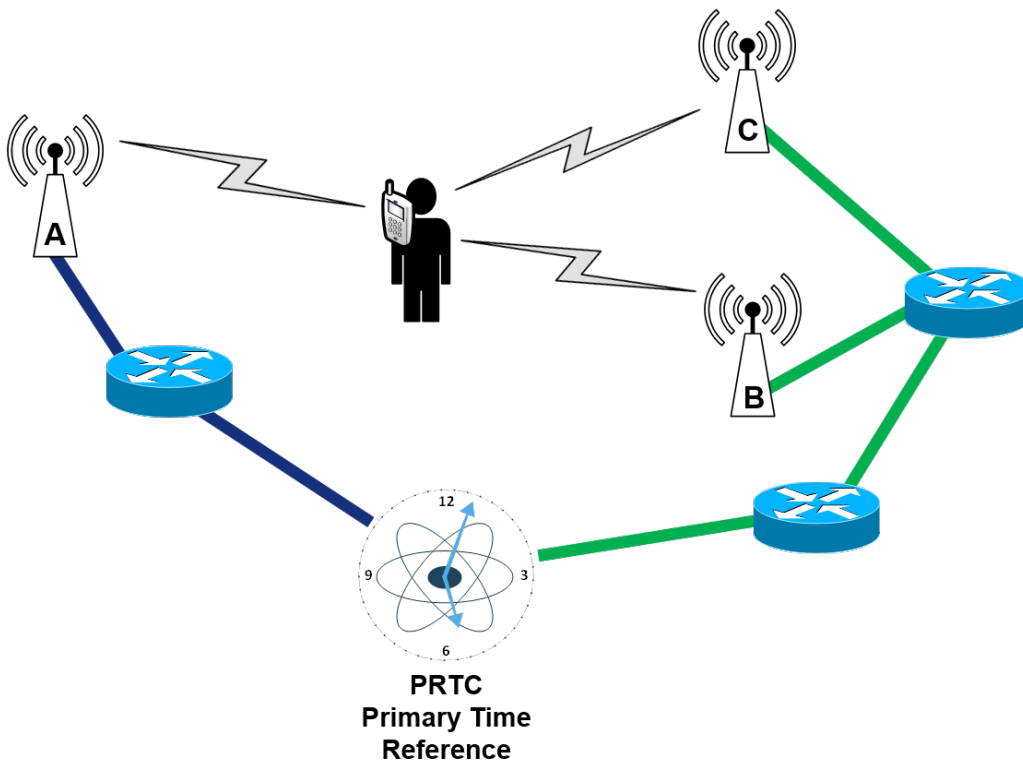

This method uses a precision time protocol (PTP) such as IEEE 1588 to transfer the ToD information across the network, removing the effects of the different distances and numbers or router hops (delays).

How Does PTP Achieve Alignment at the Network Level?

The objective is to accurately transfer time/phase information from a Grand Master (GM) time source to each radio unit over a telecom network as shown in Figure 2. This network will contain both a primary and back-up GM for redundancy. These GMs are likely located at different physical locations to avoid both going down in case of a local disruption.

Figure 2. More Detailed Network Diagram for Time / Phase Transfer

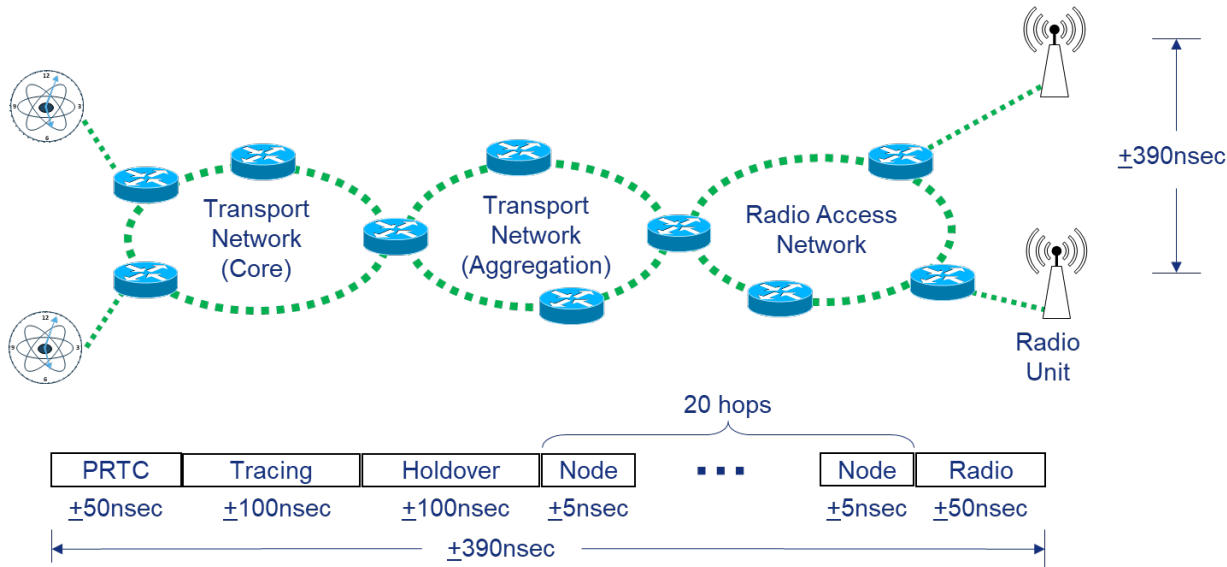

There are a variable number of network nodes between the active GM and the base-station radios in any service provider’s network. ITU standards define networks for achieving $\pm 1.5\mu\text{s}$ of phase alignment with different classes of Telecom Boundary clocks (T-BC), for instance, T-BC class B is defined to support a maximum of 20 hops between GM and radios.

Overall, a time error is allocated from the overall budget for various portions of the path. Class A and B have been standardized for some time; and Class C and D have been standardized recently with some parameters still to be defined. Figure 2 shows one such proposed budget targeting just $\pm 390\text{nsec}$ between GM and radios.

What Are the Time Error Specifications and What Do They Mean?

The Total Time Error introduced at one node is measured by comparing the time at the input to the network node with the time at the output. This is often done by examining the phase of input and output clock signals. These errors are measured continuously over a long period of time as indicated in the ITU-T G.8273.2 standard. These results are filtered and/or averaged to generate the desired figures of merit. Table 1 lists the specifications for Time Error for Telecom Boundary Clock node for the various classes.

Table 1. Targets for Time Error for a Router / Switch Node in the Various Network Classes

Network Class	Constant Time Error (cTE)	Dynamic Time Error (low-pass filtered) dTE _L MTIE	Dynamic Time Error (low-pass filtered) dTE _L TDEV	Dynamic Time Error (high-pass filtered) dTE _H	Total Time Error (low-pass filtered) maxITEL	Total Time Error maxITEL	Unit	Comment
Class A	50	40	4	70		100	ns	Standardized – 4G networks with ≤10 hops
Class B	20	40	4	70		70	ns	Standardized – 4G networks with ≤20 hops
Class C	10	10	2			30	ns	Standardized – number of networks elements still to be defined
Class D					5		ns	Standardized – number of networks elements and other parameters still to be defined

The Time Error referred to here is the error allowed at the output of the equipment with an ideal input reference. Constant Time Error (cTE) is time error that persists after the error signal is averaged over 1000 seconds. Sources of constant time error include: time stamp resolution, asymmetry of PHY transmit and receive path delays, and phase differences between the electrical clocks timing master and slave ports within a node. Dynamic Time Error (dTE) refers to the error introduced by periodically varying factors that include frequency content above that measured by constant time error. Sources of dynamic time error include: oscillator frequency drift, time stamp resolution, and PLL limit cycles.

For the remainder of this paper, the discussion will focus on cTE since that is one of the major concerns of a hardware designer of a network node.

Figure 3 illustrates 3 nodes in a telecom network. Each node is operating as a Telecom Boundary Clock (T-BC) which is the accepted method for achieving alignment across the network. In a network with full timing support, each T-BC uses the PTP protocol to align its phase to a value as closely as possible to the upstream node (i.e. closer to the Telecom Grandmaster). Note that IEEE 1588 protocol uses time of day (ToD), and ToD is used for phase alignment.

Figure 3. Time / Phase Information Transfer Between Nodes Using Telecom Boundary Clock (T-BC)

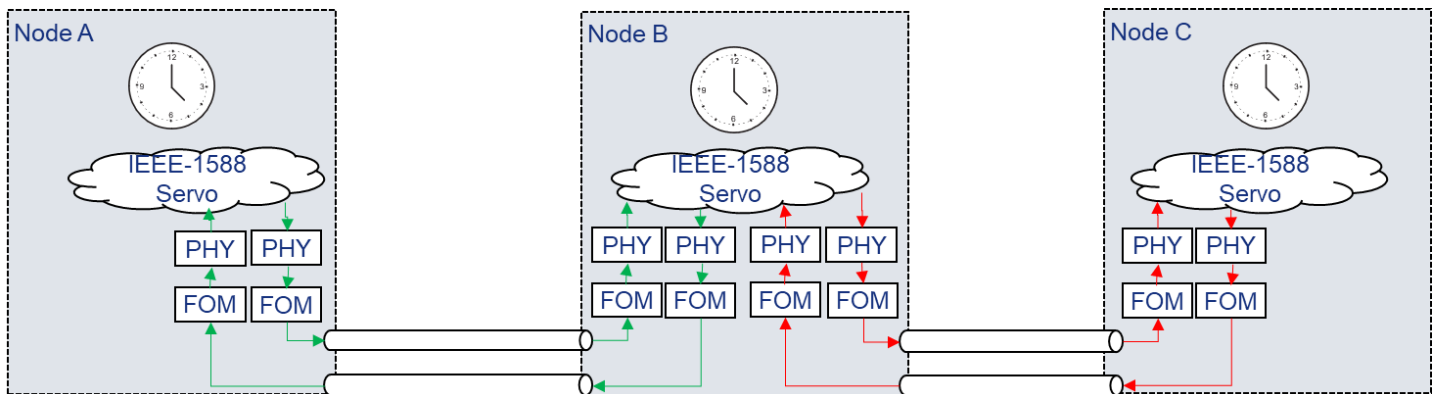

The PTP protocol involves an exchange of time-stamps between nodes over the physical interconnect channels. Fixed delays such as the propagation delays over the interconnect and through internal devices such as Physical Layer adapters (PHY) and Fiber-Optic Modules (FOM) can be determined and compensated for. After compensating, the servo will update the master ToD counter in the node with the best estimate of the ToD value considering the measurable factors. These measurements are done periodically according to the IEEE 1588 protocol.

However, there are also variable delays in the transmission paths the time stamps must traverse. These variable delays can include temperature-induced variation in propagation delays and sampling error every time the signals cross from one clock domain into another asynchronous domain. The PTP process cannot account for short-term disruptions and so it is not possible to achieve perfect phase/time accuracy between adjacent nodes. The time/phase error introduced by each node due to fixed functions that cannot be accounted for is that node's cTE.

Anecdotal information at this time of this writing indicates that even the best PHY devices can introduce 1nsec of cTE and the FOMs another 1nsec of cTE. Since there are PHY and FOM on both receive and transmit ends of each interconnect, this sets a lower bound on cTE of approximately 4nsec using today's PHY and FOM technology.

Summary

As can be seen in this Application Note, it is important for wireless infrastructure networks to be able to transmit time / phase information with minimal errors from the network Grand Master to each radio node in that network. Since one of the main methods being used is IEEE 1588 Telecom Boundary Clock protocol, implementing IEEE 1588 is increasingly important for all routers and switches that will be used at any point in a wireless infrastructure network. These nodes must meet the requirements of one of the time-error classes, including in some cases Class C or D that are just being defined at the ITU. Meeting these extremely challenging targets will be discussed in the other Application Notes in this series, culminating in a demonstration that IDT's ClockMatrix family of products are ideal for this usage model.

Glossary of Terms

Table 2. Glossary of Terms

1PPS	One Pulse-pre-Second – common synchronization clock used within networking systems. Aligns with the 1 second roll-over of the ToD timer that generates it. This is a 1Hz periodic signal but can be referenced to the rising or falling edge of each pulse. A 1PPS pulse is not required to have a 50% / 50% duty cycle.
3GPP	3 rd Generation Protocol Partnership – international standards body that defines specifications for wireless communications.
5G	5 th Generation Wireless Networking family of protocols. This is an imprecisely defined term that is loosely understood to refer to the IMT-2020 series of standards being defined by 3GPP.
CP	Charge Pump – sub-circuit within an analog PLL that converts the time-related pulse width from a Phase Detector into a control voltage that can be applied to the VCO.
cTE	Constant Time Error – error in time introduced by a single network node as it receives and transmits time / phase information. This is specifically the error introduced by fixed functions that cannot be accounted for or compensated for.
DCO	Digitally-Controlled Oscillator - sub-circuit within a PLL that contains an oscillator generating the master frequency reference within the PLL. The frequency of oscillation can be adjusted by applying different digital control values. These values are often called Frequency Control Words.
dTE	Dynamic Time Error – error in time introduced by a single network node as it receives and transmits time / phase information. This is specifically the error introduced by periodically varying factors that cannot be accounted for or compensated for.
FIFO	First-In / First-Out – a circuit that queues up pieces of information and maintains them in the order they were received.
FOM	Fiber-Optic Module

FPGA	Field-Programmable Gate Array – often used by board designers to implement complex circuits. Due to their flexible nature, FPGAs are ideal for implementation of circuits that can need changing to fully achieve the desired functionality. Unfortunately, in many cases that flexibility also leads to large uncertainty in signal propagation delays.
FR4	Fire Retardant 4 – material used in Printed Circuit Board manufacturing. FR4 is one of the cheaper options and is widely used in PCBs that don't require tightly controlled impedances, low parameter variation or support multi-GHz frequencies.
GM	Telecom Grand Master – common time reference source for a wireless infrastructure (or other) network. Capable of transmitting its reference using the IEEE 1588 protocols to other network nodes. Usually only one GM is active in any network, although one or more backups can be available to take over in case of disqualification of the active GM.
GNSS	Global Navigation Satellite System – generic term used for any of several satellite constellations used to transmit time information used to establish position on the globe or used as a common time reference. The protocols used require at least 4 satellites to be visible to any receiver to achieve the time/phase alignments discussed in these Application Notes
IDT	Integrated Device Technology – a semiconductor designer and supplier with a leading market position for timing and synchronization integrated circuits, including the ClockMatrix family.
IoT	Internet-of-Things – term used to include any device of any kind connected to the Internet. Recently there has been an exponential increase in the number of such devices as simpler devices are now able to cheaply connect to the Internet over wireless networks.
ITU	International Telecommunications Union – a standards body that defines internationally recognized specifications for the interaction of telecommunications and networking equipment
LF	Loop Filter – sub-circuit within a PLL that takes the digital words or analog control voltages from the PD and CP sub-circuits over a period of time and filters them to ensure the VCO responds smoothly to the requested changes. This is usually a low-pass filter, although more complex digital filters can be used.
PD	Phase Detector – component within a PLL device that detects the difference in time between the rising (or falling in some cases) edges of the two input signals. The output can be a voltage or pulse that is proportional to the time difference in analog PDs or a digital word in the case of digital PDs (sometimes also called TDCs).
PHY	Physical layer protocol translation device. In the context of these Application Notes, these are assumed to include a Time-of-Day counter used to time-stamp IEEE 1588 packets for minimum inaccuracy in the transfer of time/phase information.
PLL	Phase-Locked Loop
PTP	Precision Time Protocol – any protocol used across a communications network for transferring time information. In the context of these Application Notes, it refers specifically to IEEE 1588
PWM	Pulse-Width Modulation – a way of encoding extra information onto a periodic signal such as a clock
RTT	Round-Trip Time – elapsed time from when a signal is transmitted until it is looped back and received at the source
SerDes	Serializer / Deserializer – circuit within a PHY device that generates the signals on the line side of the PHY with very high speed. Reference clocks for the SerDes usually need to meet low phase noise targets to maintain low bit-error rates on the line (clean eye pattern).
SETS	Synchronous Equipment Timing Source – function within a telecommunications system that establishes and communicates the master time sources for the node
SyncE	Synchronous Ethernet protocol – defined by ITU-T G.8261. Carries data in similar packet formats as regular Ethernet, but also includes a frequency reference that can be used by all nodes in the network. Requires an unbroken path to the active GM of the network across synchronous networking protocols.

T-BC	Telecom Boundary Clock – one of several profiles within the IEEE 1588 family of standards. Defined in ITU-T 8273.2.
TDC	Time-to-Digital Converter – digital circuit that measures and reports time differences (phase errors) between the rising edge of two signals supplied to its input terminals. The output is a time measurement that can be used to drive a phase-locked loop or read by external software for use in compensation calculations. Some TDCs require periodic signals to achieve a desired accuracy whereas others can make one-shot measurements.
ToD	Time-of-Day – in the context of these Application Notes, this does not refer to a universal time standard, but rather to the time representation used in a specific wireless infrastructure network.
UTC	Universal Time Content – internationally recognized accurate time standard and format for representing it.
VCO	Voltage-Controlled Oscillator – sub-circuit within a PLL that contains an oscillator generating the master frequency reference within the PLL. The frequency of oscillation can be adjusted by applying different control voltage values.
ZDB	Zero-Delay Buffer – an application of a PLL to create multiple copies of an incoming clock signal, potentially at different output frequencies, but with minimal delay from input-output. Despite the name, delays from input-output are not zero, but are much smaller than a normal PLL implementation. A ZDB usually uses an external PCB trace to implement its feedback path. This PCB trace acts as a delay function of one period of the clock being fed back.

Revision History

Revision Date	Description of Change
February 8, 2019	Initial release of the application note.

IMPORTANT NOTICE AND DISCLAIMER

RENESAS ELECTRONICS CORPORATION AND ITS SUBSIDIARIES (“RENESAS”) PROVIDES TECHNICAL SPECIFICATIONS AND RELIABILITY DATA (INCLUDING DATASHEETS), DESIGN RESOURCES (INCLUDING REFERENCE DESIGNS), APPLICATION OR OTHER DESIGN ADVICE, WEB TOOLS, SAFETY INFORMATION, AND OTHER RESOURCES “AS IS” AND WITH ALL FAULTS, AND DISCLAIMS ALL WARRANTIES, EXPRESS OR IMPLIED, INCLUDING, WITHOUT LIMITATION, ANY IMPLIED WARRANTIES OF MERCHANTABILITY, FITNESS FOR A PARTICULAR PURPOSE, OR NON-INFRINGEMENT OF THIRD PARTY INTELLECTUAL PROPERTY RIGHTS.

These resources are intended for developers skilled in the art designing with Renesas products. You are solely responsible for (1) selecting the appropriate products for your application, (2) designing, validating, and testing your application, and (3) ensuring your application meets applicable standards, and any other safety, security, or other requirements. These resources are subject to change without notice. Renesas grants you permission to use these resources only for development of an application that uses Renesas products. Other reproduction or use of these resources is strictly prohibited. No license is granted to any other Renesas intellectual property or to any third party intellectual property. Renesas disclaims responsibility for, and you will fully indemnify Renesas and its representatives against, any claims, damages, costs, losses, or liabilities arising out of your use of these resources. Renesas' products are provided only subject to Renesas' Terms and Conditions of Sale or other applicable terms agreed to in writing. No use of any Renesas resources expands or otherwise alters any applicable warranties or warranty disclaimers for these products.

(Rev.1.0 Mar 2020)

Corporate Headquarters

TOYOSU FORESIA, 3-2-24 Toyosu,
Koto-ku, Tokyo 135-0061, Japan
www.renesas.com

Contact Information

For further information on a product, technology, the most up-to-date version of a document, or your nearest sales office, please visit:
www.renesas.com/contact/

Trademarks

Renesas and the Renesas logo are trademarks of Renesas Electronics Corporation. All trademarks and registered trademarks are the property of their respective owners.