

Introduction

There are many power management applications using MOSFETs that require no reverse current leakage when controlling a power rail. Due to the nature of a MOSFET, the body diode can conduct current when the source voltage is higher than the drain voltage (the MOSFET is OFF). This condition prevents the MOSFET from blocking any reverse current causing an undesirable design behavior. Using two GreenFET family load switches back-to-back prevents this condition from occurring and provides many features that make designers life much easier. Some of these features are low $R_{ds(ON)}$ resistance, slew rate control, inrush current management, over-current, over-voltage and thermal protection.

Dual Load Switches with Common Source Circuit Behavior

When the load switch is off, the MOSFET still has the body diode conducting high current if the load voltage (source) goes more than a diode drop above the drain. For example, with embedded battery applications this can result in a path that can quickly drain the battery. A reverse blocking architecture essentially places two load switches in a back-to-back configuration that makes it impossible for the current to go through the body diodes because of their opposing conduction directions. The only drawback to this design is that two MOSFETs in series may increase the $R_{ds(ON)}$ of the final load switch. However, has many Load Switches with various $R_{ds(ON)}$ to choose from. Figure 1 shows only the MOSFET portion of the load switch including VIN (drain of Q1), VS (common sources of Q1&Q2), VOUT (drain of Q2), and OE (gate enable control). GreenFET load switches also have drain detection circuitry that keeps the drain off until a voltage is applied.

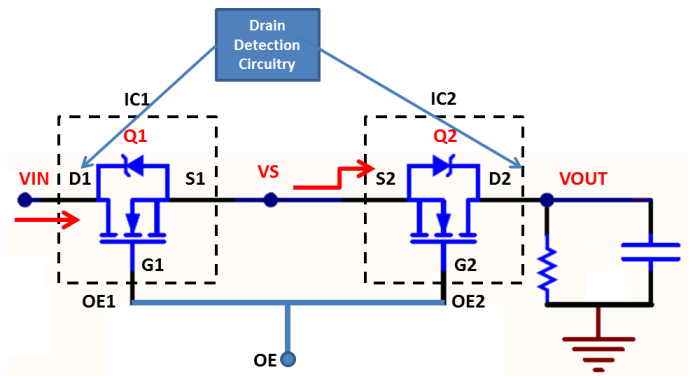

Figure 1. Dual Load Switch Connection with Common Sources

When OE is asserted, Q1 is immediately turned on and voltage is supplied to VS within a few μs . See Figure 2.

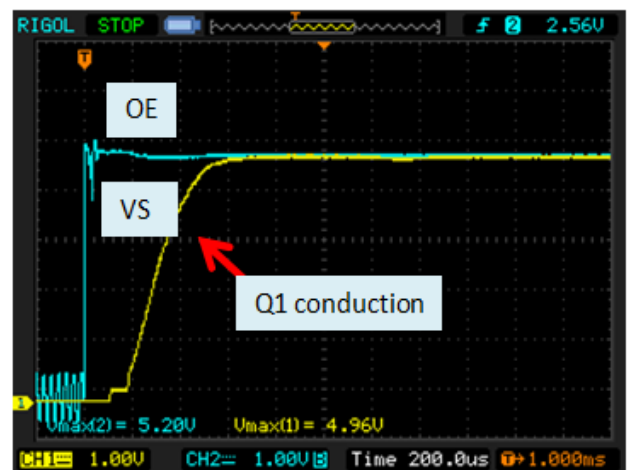

Figure 2. Waveform at VS Node (sources of Q1 & Q2)

As long as the Q2 drain (VOUT) is still at 0V, Q2 is off. When VS starts ramping up, VOUT starts ramping up as well through the conducting body diode and remains one diode drop below VS until Q2 turns on. Once Q2 is on, VOUT ramps up to the correct supply level shown in Figure 3.

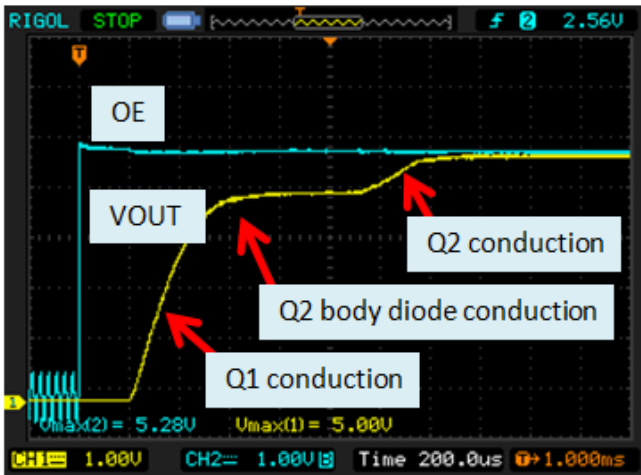

Figure 3. Waveform at VD2 node (Drain of Q4)

Conclusion

All GreenFET load switches not only can be used in reverse current blocking applications but also can add value to design by providing many features that makes the application more robust and cost effective.