



Total dose testing of the HS-117RH adjustable positive voltage linear regulator

Nick van Vonno
Intersil Corporation

Revision 1
1 September 2011

Table of Contents

- 1. Introduction**
- 2. Reference Documents**
- 3. Part Description**
- 4. Test Description**
 - 4.1 Irradiation facility**
 - 4.2 Test fixturing**
 - 4.3 Characterization equipment and procedures**
 - 4.4 Experimental Matrix**
 - 4.5 Downpoints**
- 5 Results**
 - 5.1 Test results**
 - 5.2 Variables data**
- 6 Discussion**
- 7 Conclusion**
- 8 Appendices**
- 9 Document revision history**

1. Introduction

This report reports the results of a low and high dose rate total dose test of the HS-117RH adjustable positive voltage linear regulator. The test was conducted in order to determine the sensitivity of the part to the total dose environment and to determine if dose rate and bias sensitivity exist.

Intersil markets two versions of the HS-117RH. The base HS-117RH is acceptance tested on a wafer by wafer basis to 300 krad(Si) at high dose rate, as defined in MIL-STD-883 test method 1019 (50 – 300 rad(Si)/s). The HS-117EH is acceptance tested on a wafer by wafer basis to 300 krad(Si) at high dose rate, as defined in MIL-STD-883 test method 1019 (50 – 300 rad(Si)/s), and to 50 krad(Si) at low dose rate, also as defined in method 1019 (0.01 rad(Si)/s maximum). The HS-117RH and HS-117EH are identical parts.

2. Reference Documents

MIL-STD-883G test method 1019.7

HS-117RH data sheet

DSCC Standard Microcircuit Drawing (SMD) 5962-99547

3: Part Description

The radiation hardened HS-117RH is an adjustable positive voltage linear regulator capable of operating with input voltages up to 40VDC. The output voltage is adjustable from 1.2V to 37V with two external resistors. The device is capable of sourcing from 5mA to 1.25A peak (0.5 A peak for the TO-39 package). Protection is provided by on-chip thermal shutdown and output current limiting circuitry. A block diagram of the part is shown in Figure 1.

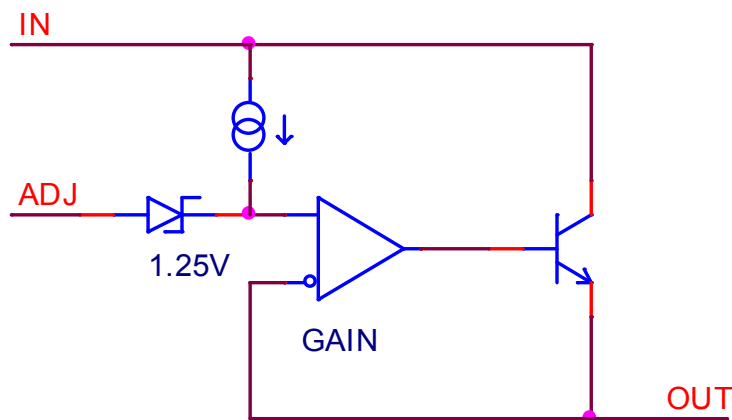

Figure 1: HS-117RH block diagram.

The Intersil HS-117RH has advantages over other industry standard types, in that circuitry is incorporated to minimize the effects of radiation and temperature on device stability. Constructed with the Intersil dielectrically isolated Rad Hard Silicon Gate (RSG) process, the HS-117RH is

immune to single event latch-up and has been specifically designed to provide reliable performance in harsh radiation environments.

Specifications for Rad Hard QML devices are controlled by the Defense Supply Center in Columbus (DSCC). Detailed electrical specifications for the HS-117RH are contained in SMD 5962-99547. A "hot-link" is provided on the Intersil website for downloading.

4: Test Description

4.1 Irradiation Facilities

High dose rate testing was performed using a Gammacell 220 ⁶⁰Co irradiator located in the Palm Bay, Florida Intersil facility. Low dose rate testing was performed on a subcontract basis at White Sands Missile Range (WSMR) Survivability, Vulnerability and Assessment Directorate (SVAD), White Sands, NM. The high dose rate irradiations were done at 55rad(Si)/s and the low dose rate work was performed at 0.010rad(Si)/s, both per MIL-STD-883 Method 1019.7. Dosimetry for both tests was performed using Far West Technology radiochromic dosimeters and on-site readout equipment. A PbAl box was used to shield the test fixture and devices under test against low energy secondary gamma radiation.

4.2 Test Fixturing

Figure 2 shows the configuration used for biased irradiation in conformance with Standard Microcircuit Drawing (SMD) 5962-99547.

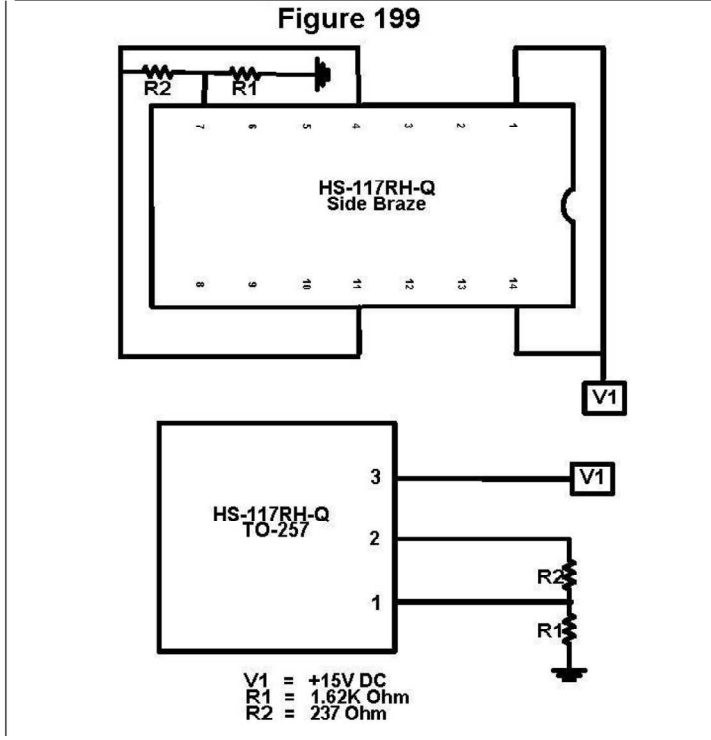

Title: RAD HARD FIGURE HS-117RH MASK # 52316 Specification Type: DOCS Specification Number: 233032-001-199
 Issue: 2
 Page: 1 of 1
 These Drawings and Specifications are the Property of Intersil Corporation and shall not be used, reproduced or copied without Written Permission

Figure 2: Irradiation bias configuration for the HS-117RH per Standard Microcircuit Drawing (SMD) 5962-99547.

4.3 Characterization equipment and procedures

All electrical testing was performed outside the irradiator using the production automated test equipment (ATE) with datalogging at each downpoint. Downpoint electrical testing was performed at room temperature. The low dose rate testing at a remote site introduced some challenges, and shipping had to be done in a foam container with a frozen Gelpack™ along with a strip chart temperature recorder in order to remain well within the temperature limits imposed by MIL-STD-883 Test Method 1019.7.

4.4 Experimental matrix

Testing proceeded in accordance with the guidelines of MIL-STD-883 Test Method 1019.7. The experimental matrix consisted of five samples irradiated at high dose rate with all pins grounded, five samples irradiated at high dose rate under bias, five samples irradiated at low dose rate with all pins grounded and five samples irradiated at low dose rate under bias. One control unit was used.

Samples of the HS-117RH die were drawn from wafer 18 of production lot DCXJ2QA and were packaged in the standard hermetic three-terminal Ceramic Leadless Chip Carrier (CLCC) production package. Samples were processed through the standard burnin cycle before irradiation, as required by MIL-STD-883, and were screened to the SMD 5962-99547 limits at room, low and high temperatures prior to the test.

4.5 Downpoints

Downpoints for the tests were zero, 50krad(Si), 100krad(Si) and 150krad(Si) for the high dose rate test and zero, 10krad(Si), 25krad(Si), 50krad(Si), 100krad(Si), 125krad(Si) and 150krad(Si) for the low dose rate test.

5: Results

5.1 Test results

Testing at both dose rates to 150krad(Si) of the HS-117RH is complete and showed no reject devices after irradiation to 150krad(Si), screening to the SMD post-irradiation limits. As a determinant of low dose rate sensitivity, MIL-STD-883 Test Method 1019.7 specifies that a delta_parameter calculation be performed for any 'sensitive parameters' that exceed the pre-irradiation Group A limits, but not necessarily the post-irradiation limits. These calculations were not required as there were no rejects against the pre-irradiation Group A limits, meaning there are no formal 'sensitive parameters'.

It should be noted, however, that the line regulation showed considerable change (Figure 5, below) and was near the 0.02%/V pre- and post-irradiation limit at the 150krad(Si) downpoint. None of the samples exceeded the limits. Accordingly, the part is considered moderately ELDRS sensitive up to 150krad(Si).

5.2 Variables data

The plots in Figures 3 through 10 show data at all downpoints. The plots show the median of key parameters as a function of total dose for each of the four irradiation conditions.

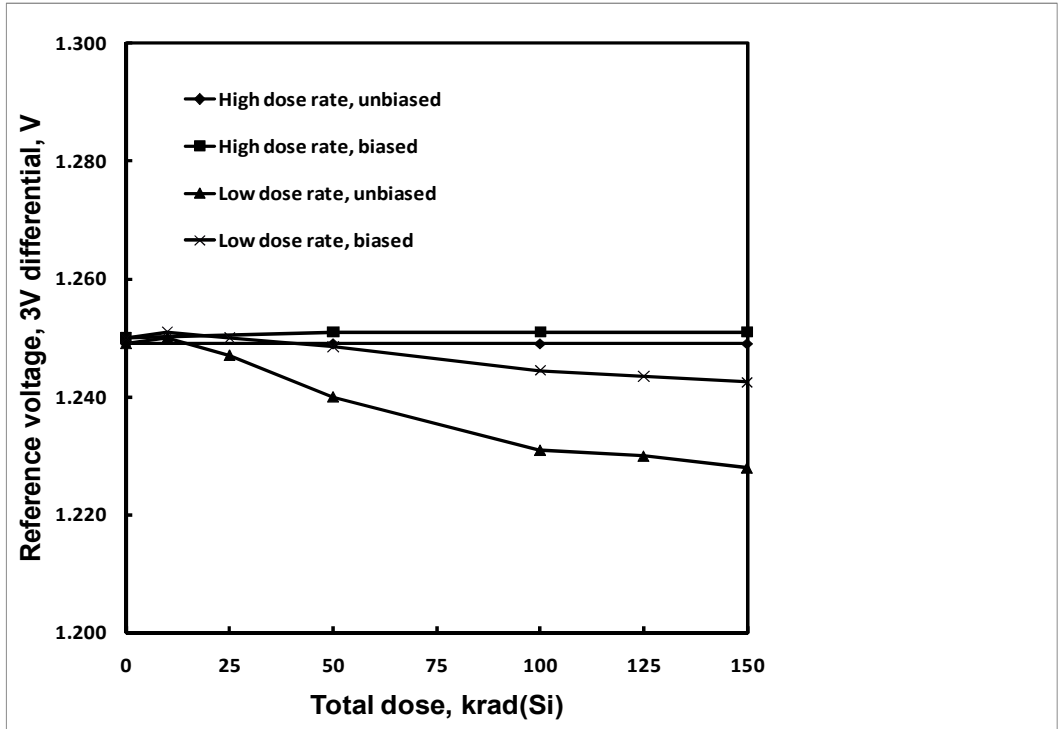

Figure 3: HS-117RH reference voltage at 3V differential voltage as a function of total dose irradiation at low and high dose rate for the unbiased (all pins grounded) and the biased (per Figure 2) cases. The low dose rate was 0.01rad(Si)/s and the high dose rate 55rad(Si)/s. Sample size for each cell was 5. The post-irradiation SMD limits are 1.2V to 1.3V.

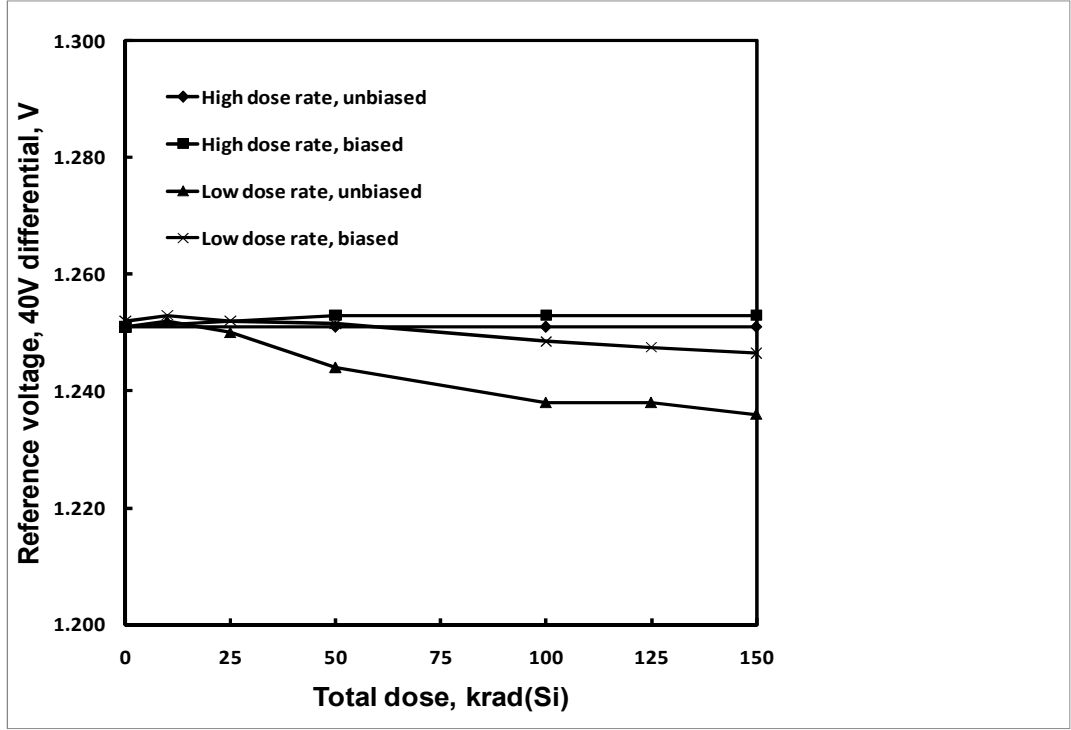

Figure 4: HS-117RH reference voltage at 40V differential voltage as a function of total dose irradiation at low and high dose rate for the unbiased (all pins grounded) and the biased (per Figure 2) cases. The low dose rate was 0.01rad(Si)/s and the high dose rate was 55rad(Si)/s. Sample size for each cell was 5. The post-irradiation SMD limits are 1.2 to 1.3V.

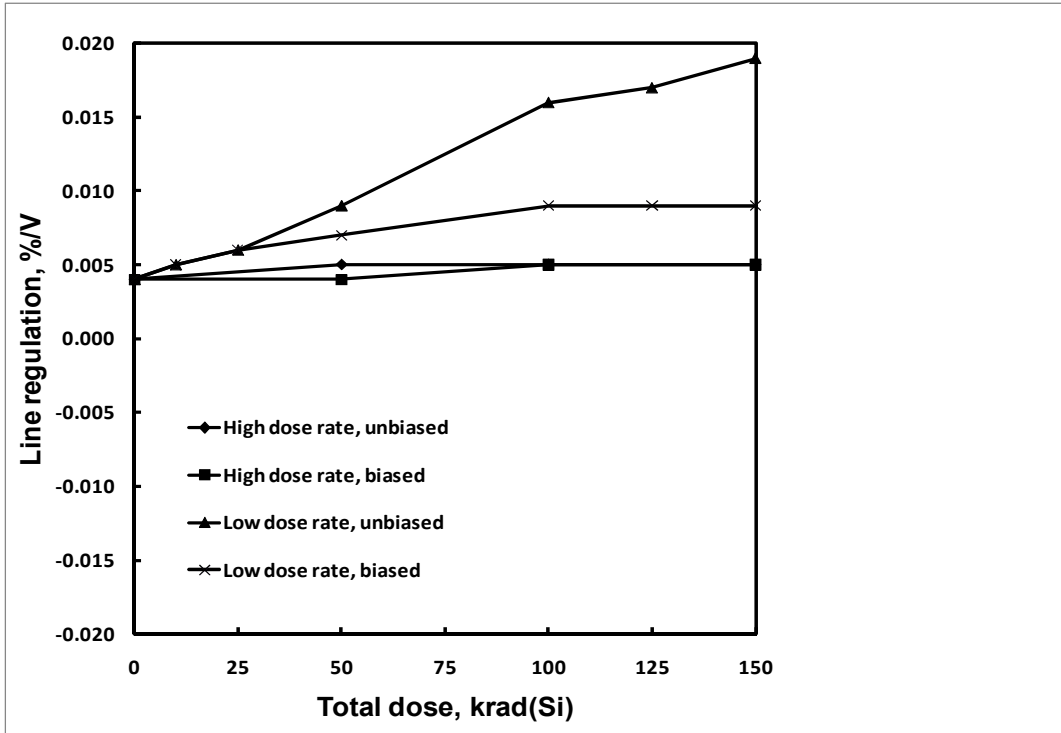

Figure 5: HS-117RH line regulation as a function of total dose irradiation at low and high dose rate for the unbiased and biased cases. The post-irradiation SMD limits are -0.02%/V to 0.02%/V.

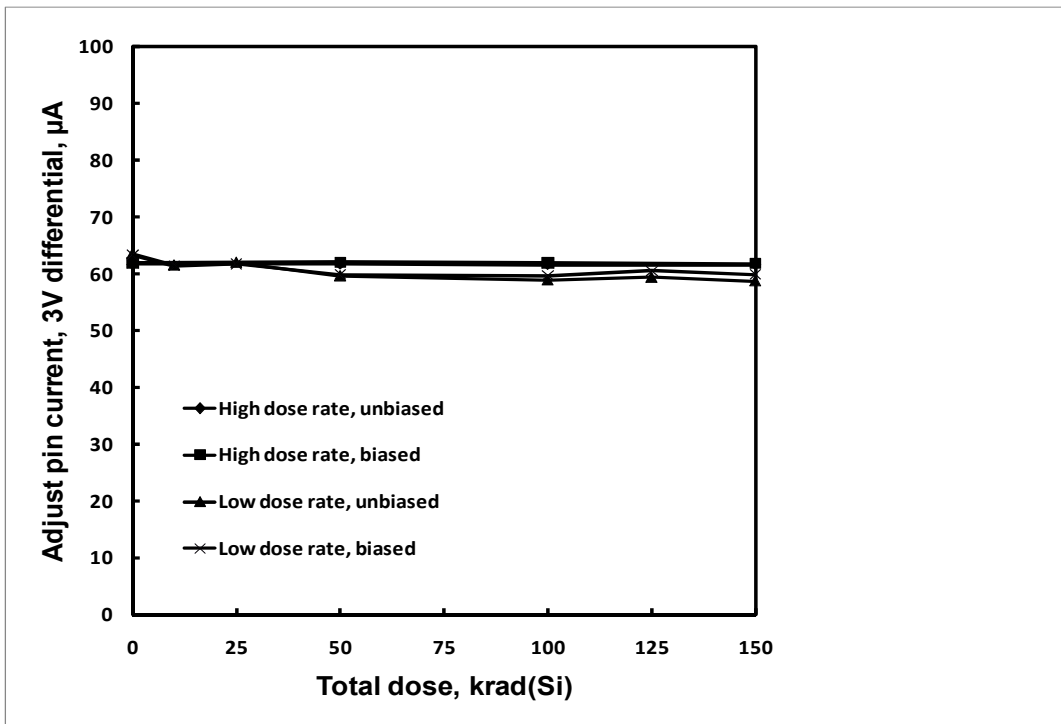

Figure 6: HS-117RH adjust pin current at 3V differential as a function of total dose irradiation at low and high dose rate for the unbiased and biased cases. The post-irradiation SMD limit is 100µA.

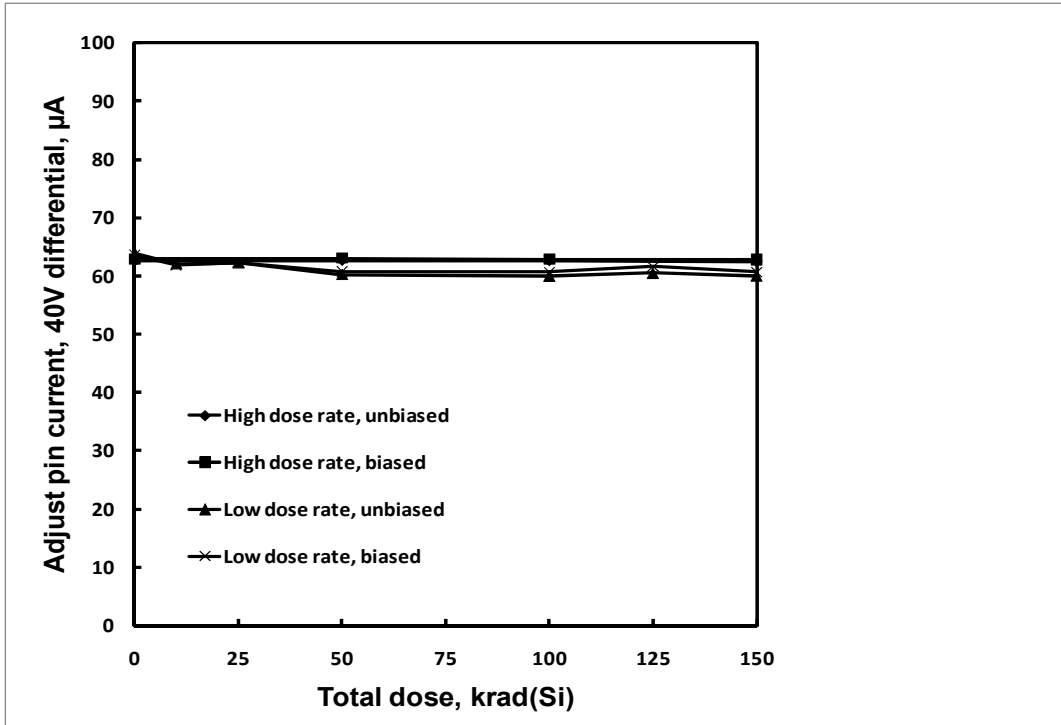

Figure 7: HS-117RH adjust pin current at 40V differential as a function of total dose irradiation at low and high dose rate for the unbiased and biased cases. The post-irradiation SMD limit is 100μA.

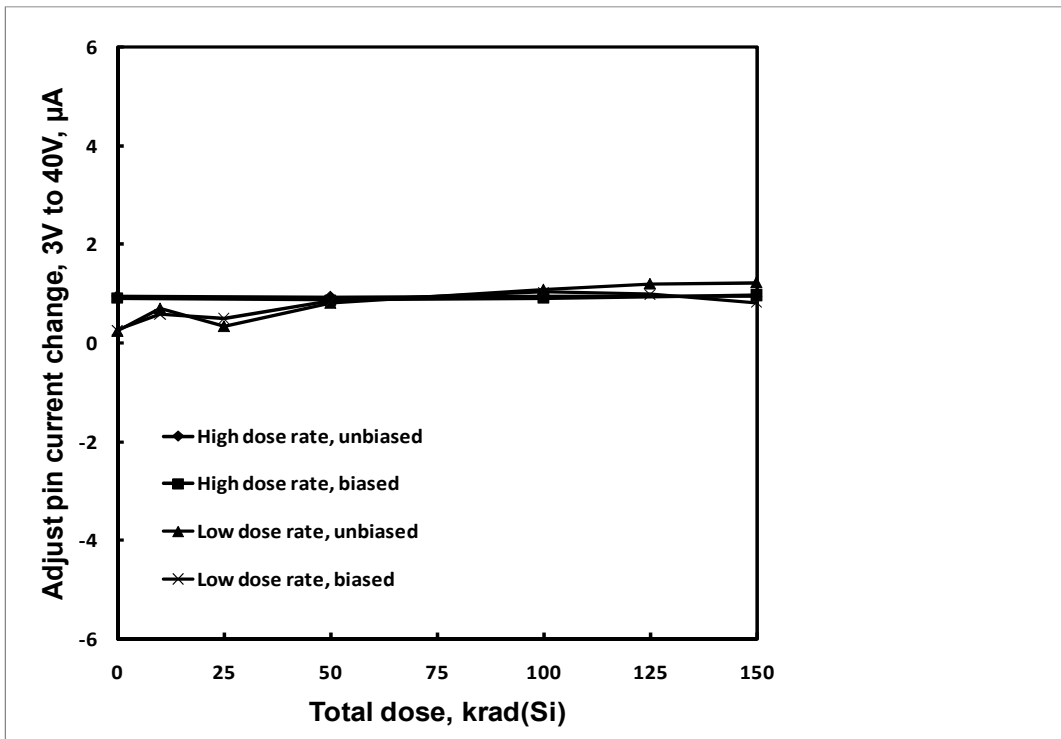

Figure 8: HS-117RH adjust pin current change, 3V to 40V differential, as a function of total dose irradiation at low and high dose rate for the unbiased and biased cases. The post-irradiation SMD limit is -6μA to 6μA.

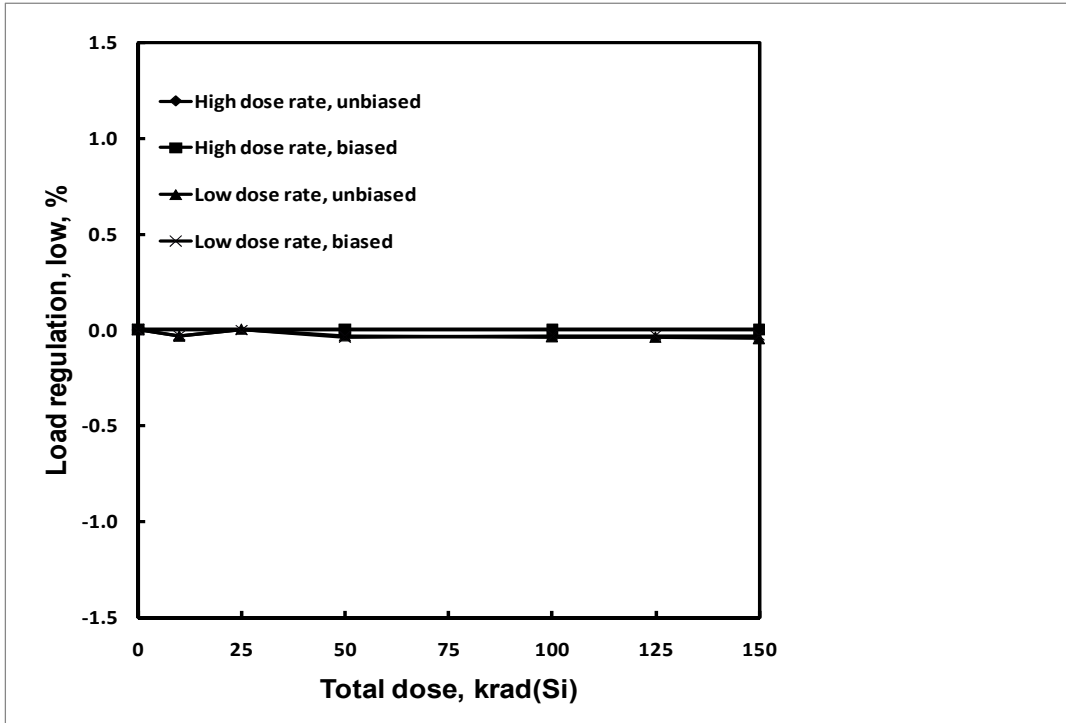

Figure 9: HS-117RH load regulation, 5mA to 500mA, as a function of total dose irradiation at low and high dose rate for the unbiased and biased cases. The post-irradiation SMD limits are -1.5% to 1.5%.

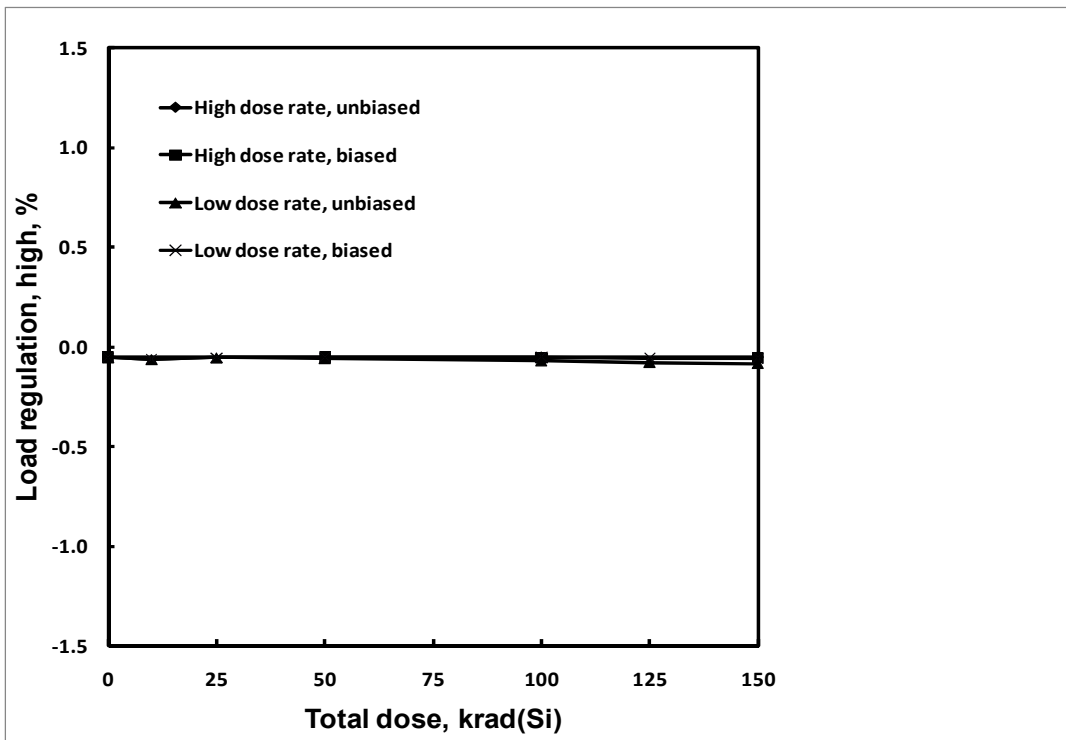

Figure 10: HS-117RH load regulation, 5mA to 1.25A, as a function of total dose irradiation at low and high dose rate for the unbiased and biased cases. The post-irradiation SMD limits are -1.5% to 1.5%.

6: Conclusion

This document reports results of a total dose test of the HS-117RH adjustable positive voltage linear regulator. Parts were tested at low and high dose rate under biased and unbiased conditions as outlined in MIL-STD-883 Test Method 1019.7, to a maximum total dose of 150krad(Si).

Testing at both dose rates to 150krad(Si) of the HS-117RH is complete and showed no reject devices after irradiation to 150krad(Si), screening to the SMD post-irradiation limits. As a determinant of low dose rate sensitivity, MIL-STD-883 Test Method 1019.7 specifies that a delta_parameter calculation be performed for any 'sensitive parameters' that exceed the pre-irradiation Group A limits, but not necessarily the post-irradiation limits. These calculations were not required as there were no rejects against the pre-irradiation Group A limits, meaning there are no 'sensitive parameters'.

It should be noted that the line regulation showed considerable change and was near the 0.02%/V pre- and post-irradiation limit at the 150krad(Si) downpoint. Accordingly, the part is considered moderately ELDRS sensitive up to 150krad(Si).

Several of the low dose rate curves display some bias sensitivity, but none exceeded the post-radiation SMD specifications.

7: Appendices

7.1: Reported parameters.

Figure	Parameter	Limit, low	Limit, high	Units	Notes
3	Reference voltage	1.2	1.3	V	3V differential
4	Reference voltage	1.2	1.3	V	40V differential
5	Line regulation	-0.02	0.02	%/V	
6	Adjust pin current		100	μA	3V differential
7	Adjust pin current		100	μA	40V differential
8	Adjust pin current change	-6	6	μA	3V to 40V differential
9	Load regulation, low	-1.5	1.5	%	5mA to 500mA
10	Load regulation, high	-1.5	1.5	%	5mA to 1.25A

Note 1: Limits are taken from Standard Microcircuit Drawing (SMD) 5962-99547.

8: Document revision history

Revision	Date	Pages	Comments
0	28 June 2010	All	Original issue
1	1 Sept 2011	2	Add description of –EH version