

**ISL71590SEH, ISL73590SEH**

Radiation Hardened, 2-Terminal Temperature Transducer

FN8376  
Rev.3.00  
Sep 14, 2018

The [ISL71590SEH](#) and [ISL73590SEH](#) are temperature-to-current transducers possessing two terminals. They have a high impedance current output that allows them to be insensitive to voltage drops across long lines. When provided a differential voltage between 4V and 33V, the devices act as constant current regulators that generate a current equal to 1μA/Kelvin (K).

These devices are specified across the -55°C to +125°C temperature range and with ±1.7°C accuracy without the need of additional circuitry, and also capable of operating up to +150°C. With power requirements as low as 1.5mW (5V at +25°C), they are an ideal choice for remote sensing applications as any well-insulated twisted pair cable will allow for proper operation. They can be used in several additional applications including temperature compensation networks, flow rate analysis, anemometry, and biasing proportional to absolute temperature.

The high output impedance (>10MΩ) leaves plenty of room for variations in the power supply voltage. The ISL7x590SEH is electrically durable as it can withstand a forward operating voltage of 33V over the full temperature range both under and without ion beam radiation and a reverse voltage of -40V.

The ISL71590SEH and ISL73590SEH are available in 2 Ld flatpacks and die forms. All material applies to both parts except for TID assurance test levels.

**Applications**

- RF power amplifier bias compensation
- LCD bias compensation
- Laser diode bias compensation
- Sensor bias and linearization
- Data acquisition systems

**Features**

- 50krad(Si) low dose rate (ELDRS) shift. . . . . < 1°C
  - Linear output current. . . . . 1μA/K
  - Wide power supply input range (V+ to V-). . . . . 4V to 33V
  - Low power consumption . . . . . 1.5mW at 5V
  - High output impedance provides excellent rejection to variations in the supply line
  - Additional linearization circuitry is not needed for operation
  - Operating temperature range. . . . . -55°C to +150°C
  - QML qualified per MIL-PRF-38535 requirements
  - Radiation environment
    - SEL/SEB LET<sub>TH</sub> . . . . . 86.4MeV • cm<sup>2</sup>/mg
    - Total dose, high dose rate. . . . . 300krad(Si)\*
    - Total dose, low dose rate . . . . . 50krad(Si)
- \*Applies to the ISL71590SEH only.
- Electrically screened to SMD# [5962-13215](#)

**Related Literature**

For a full list of related documents, visit our website

- [ISL71590SEH](#) and [ISL73590SEH](#) product pages

**TABLE 1. KEY DIFFERENCES BETWEEN FAMILY OF PARTS**

PART NUMBER	HIGH DOSE RATE (HDR) ASSURANCE TEST LEVEL (krad(Si))	LOW DOSE RATE (LDR) ASSURANCE TEST LEVEL (krad(Si))
ISL71590SEH	300	50
ISL73590SEH	N/A	50

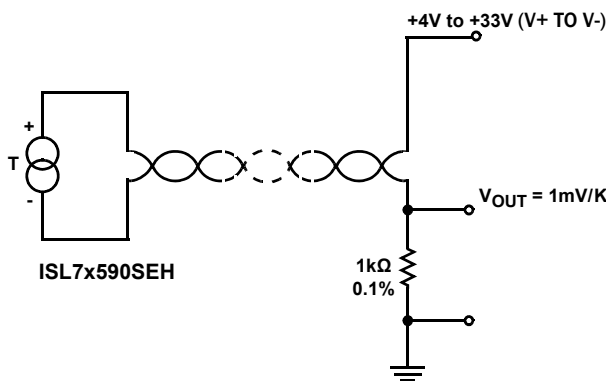

**FIGURE 1. TYPICAL APPLICATION**

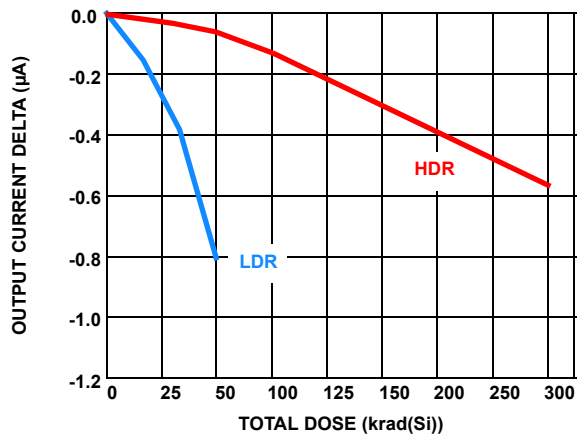

**FIGURE 2. I<sub>OUT</sub> SHIFT vs LOW/HIGH DOSE RATE RADIATION**

## Ordering Information

ORDERING SMD NUMBER (Note 2)	PART NUMBER (Note 1)	HIGH DOSE RATE (HDR) krad(Si)	LOW DOSE RATE (LDR) krad(Si)	TEMPERATURE RANGE (°C)	PACKAGE (RoHS COMPLIANT)	PKG. DWG. #
5962F1321501VXC	ISL71590SEHVF	300	50	-55 to +125	2 Ld Flatpack	K2.A
5962F1321501V9A	ISL71590SEHVX	300	50	-55 to +125	Die	
5962L1321502VXC	ISL73590SEHVF	N/A	50	-55 to +125	2 Ld Flatpack	K2.A
5962L1321502V9A	ISL73590SEHVX	N/A	50	-55 to +125	Die	
N/A	ISL71590SEHF/PROTO (Note 3)	N/A	N/A	-55 to +125	2 Ld Flatpack	K2.A
N/A	ISL71590SEHX/SAMPLE (Note 3)	N/A	N/A	-55 to +125	Die	
N/A	ISL71590SEHMF	300	50	-55 to +125	2 Ld Flatpack	K2.A
N/A	ISL71590SEHEV1Z (Note 4)	Evaluation Board				

### NOTES:

- These Pb-free Hermetic packaged products employ 100% Au plate - e4 termination finish, which is RoHS compliant and compatible with both SnPb and Pb-free soldering operations.
- Specifications for Rad Hard QML devices are controlled by the Defense Logistics Agency Land and Maritime (DLA). The SMD numbers listed must be used when ordering.
- The /PROTO and /SAMPLE are not rated or certified for Total Ionizing Dose (TID) or Single Event Effect (SEE) immunity. These parts are intended for engineering evaluation purposes only. The /PROTO parts meet the electrical limits and conditions across temperature specified in the DLA SMD and are in the same form and fit as the qualified device. The /SAMPLE parts are capable of meeting the electrical limits and conditions specified in the DLA SMD at +25°C only. The /SAMPLE parts do not receive 100% screening across temperature to the DLA SMD electrical limits. These part types do not come with a Certificate of Conformance because they are not DLA qualified devices.
- Evaluation board uses the /PROTO parts. The /PROTO parts are not rated or certified for Total Ionizing Dose (TID) or Single Event Effect (SEE) immunity.

## Pin Configuration

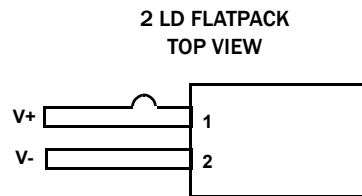

## Pin Descriptions

PIN NUMBER	PIN NAME	EQUIVALENT ESD CIRCUIT	DESCRIPTION
1	V+	Circuit 1	Positive voltage lead range 4V to 33V
2	V-	Circuit 1	Negative voltage lead

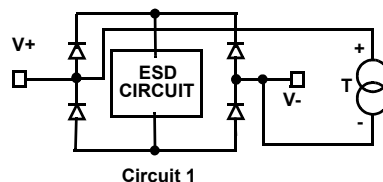

# Functional Block Diagram

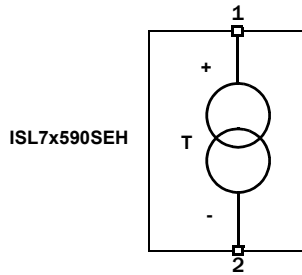

FIGURE 3. BLOCK DIAGRAM

## Typical Applications

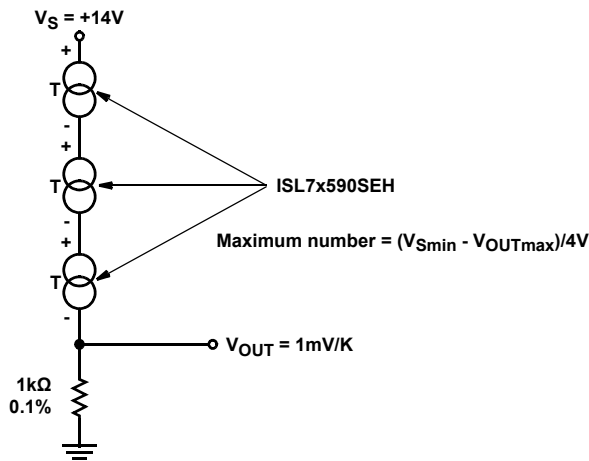
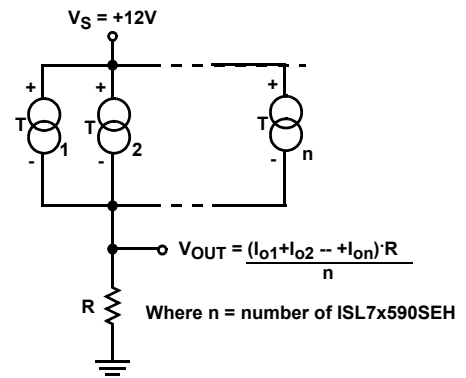

FIGURE 4. LOWEST TEMPERATURE SENSING SCHEME. OUTPUT CURRENT IS THAT OF THE “COLDEST” SENSOR



(e.g., with four sensors and R = 250Ω V<sub>OUT</sub> = 1mV/K)

FIGURE 5. AVERAGE TEMPERATURE SENSING SCHEME. OUTPUT CURRENT IS THE SUM OF ALL SENSOR CURRENTS

**Absolute Maximum Ratings**

Maximum Supply Voltage	40V
In-Beam Maximum Supply Voltage (Note 7)	37V
Maximum Reverse Voltage	-40V
Maximum Differential Input Voltage	±40V
Case to Lead Breakdown Voltage	±200V
<b>ESD Rating</b>	
Human Body Model (Tested per MIL-STD-883 TM3015.7)	3kV
Machine Model (Tested per EIA/JESD22-A115-A)	300V
Charged Device Model (Tested per JESD22-C101D)	750V

**Thermal Information**

Thermal Resistance (Typical)	$\theta_{JA}$ (°C/W)	$\theta_{JC}$ (°C/W)
2 Ld Flatpack (Notes 5, 6)	80	8
Storage Temperature Range	-65°C to +155°C	
Maximum Junction Temperature (T <sub>JMAX</sub> )	+150°C	

**Recommended Operating Conditions**

Ambient Operating Temperature Range	-55°C to +125°C
Maximum Operating Junction Temperature	+150°C
Supply Voltage (V+ to V-) (Notes 7, 8)	4V to 33V

**CAUTION:** Do not operate at or near the maximum ratings listed for extended periods of time. Exposure to such conditions may adversely impact product reliability and result in failures not covered by warranty.

**NOTES:**

- $\theta_{JA}$  is measured in free air with the component mounted on a high-effective thermal conductivity test board with “direct attach” features. See Tech Brief [TB379](#).
- For  $\theta_{JC}$ , the “case temp” location is the center of the ceramic on the package underside.
- The maximum supply voltage specified is for operation in a heavy ion environment at an LET = 86.4MeV • cm<sup>2</sup>/mg.
- The maximum voltage beyond which output current performance is not to be considered valid ([Figure 9](#)).

**Electrical Specifications**  $V_S = 5V, T_A = +25^\circ C$ , unless otherwise noted. **Boldface limits apply across the operating temperature range, -55°C to +125°C.**

PARAMETER	SYMBOL	TEST CONDITIONS	MIN (Note 9)	TYP	MAX (Note 9)	UNIT
Power Supply Voltage Range	$V_S$	(V+ to V-) (Note 7)	<b>4</b>		<b>31</b>	V
Nominal Current Output	$I_O$			298.1		μA
Ambient Error Accuracy	E		<b>-0.50</b>	-0.05	<b>0.50</b>	°C
Current Output Temperature Coefficient	$TCI_O$			1		μA/K
Absolute Error without External Calibration	$E_A$	Over full temperature range	<b>-2.0</b>		<b>2.0</b>	°C
Nonlinearity	NL	At 5 discrete temperature points	<b>-0.5</b>		<b>0.5</b>	°C
Repeatability	RPT	After temperature range end point cycling	-0.1		0.1	°C
Long Term Drift	dE/dt	V+ = 31V for 1khr at +125°C	-0.25	-0.05	0.25	°C
Output Current $V_S$ Rejection	PSRR	$5V > V_S > 4V$		0.05	<b>0.50</b>	μA/V
		$5V \leq V_S \leq 15V$		0.03	<b>0.20</b>	μA/V
		$5V \leq V_S \leq 31V$		0.04	<b>0.10</b>	μA/V
Voltage Noise Density	$V_{nd}$	f = 100Hz		0.03		μV/√Hz
Current Noise Density	$I_{nd}$	f = 100Hz		30		pA/√Hz
Case Isolation to Either Lead	I <sub>SO</sub>	Case to lead voltage = 200V		10 <sup>10</sup>		Ω
Effective Shunt Capacitance	$C_S$	f = 10Hz		65		pF
Electrical Turn-On Time	$t_{ON}$	$V_S = 4V$ to $I_{OUT}$ stable		2		μs
-10V Reverse Bias Leakage Current	$I_{LEAK}$	+125°C = Worst case		50		nA
<b>POST RADIATION</b>						
Post Low Dose Rate Radiation (LDR) Ambient Error 50krad at 0.01rad(Si)/s	E-RADD ( <a href="#">Figure 19</a> )	Ambient error accuracy plus TID shift ( <a href="#">Note 10</a> )	<b>-2.0</b>		<b>0.5</b>	°C
Post High Dose Rate Radiation (HDR) Ambient Error 300krad at 70rad(Si)/s		Ambient error accuracy plus TID shift ( <a href="#">Note 10</a> ) (ISL71590SEH only)	<b>-2.0</b>		<b>0.5</b>	°C

**NOTES:**

- Compliance to datasheet limits is assured by one or more methods: production test, characterization, and/or design.
- The post radiation Ambient Error specs are defined as the absolute temperature error.

**TABLE 2. BURN-IN AND LIFE TEST DELTA PARAMETERS**

PARAMETER	SYMBOL	BURN-IN END POINT	BURN-IN DELTA	MIL-STD GROUP C END POINT	MIL-STD GROUP C DELTA	UNITS
Ambient Error (+25°C)	E	±0.5	±0.25	±0.5	±0.25	°C

**Typical Performance Curves** Unless otherwise specified,  $V_S = 5V$ ,  $T_A = +25^\circ C$ .

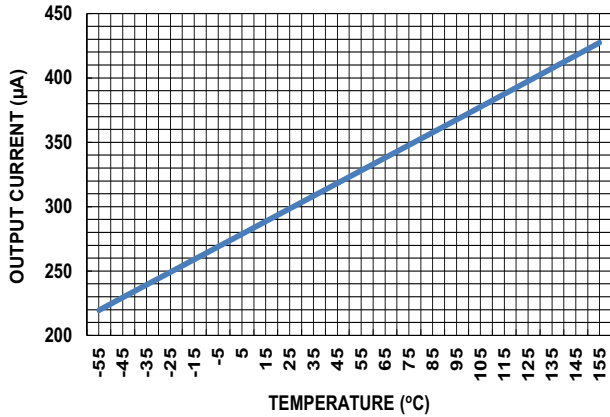

**FIGURE 6. OUTPUT CURRENT vs TEMPERATURE**

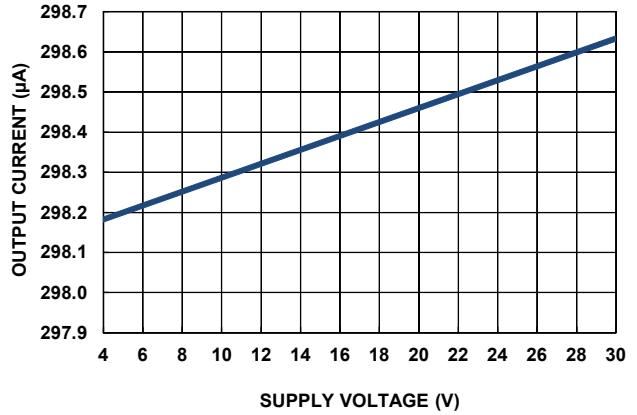

**FIGURE 7. OUTPUT CURRENT vs  $V_S$  VOLTAGE**

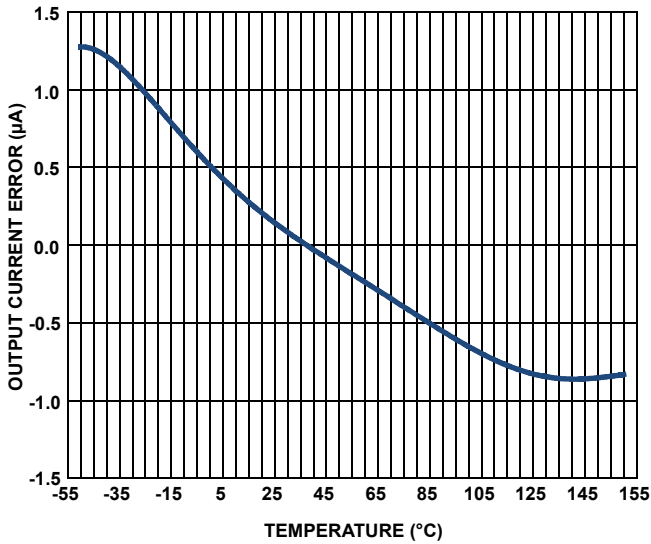

**FIGURE 8. TYPICAL ABSOLUTE ERROR WITHOUT EXTERNAL CALIBRATION vs TEMPERATURE**

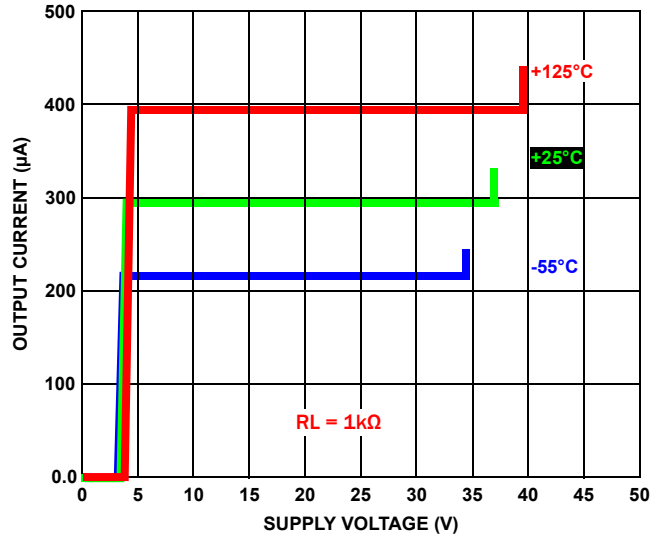

**FIGURE 9. VI CURVE OF  $V_S$  vs  $I_{OUT}$  OVER-TEMPERATURE**

# Typical Performance Curves Unless otherwise specified, $V_S = 5V$ , $T_A = +25^\circ C$ . (Continued)

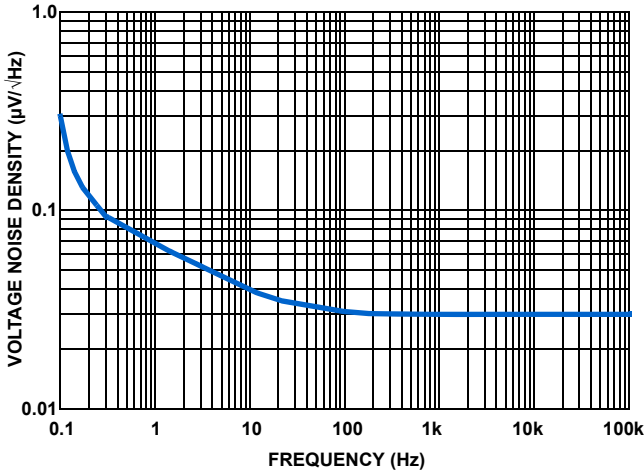

FIGURE 10. VOLTAGE NOISE DENSITY vs FREQUENCY

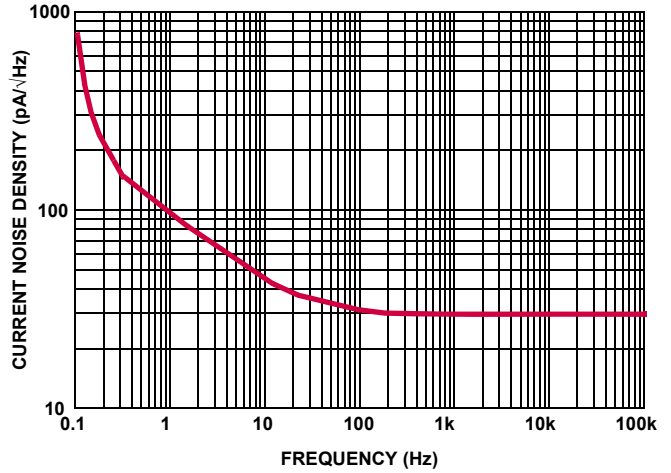

FIGURE 11. CURRENT NOISE DENSITY vs FREQUENCY

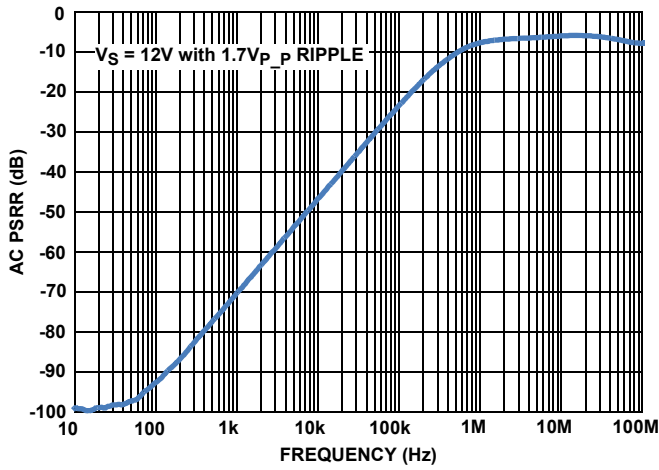

FIGURE 12. AC PSRR vs FREQUENCY

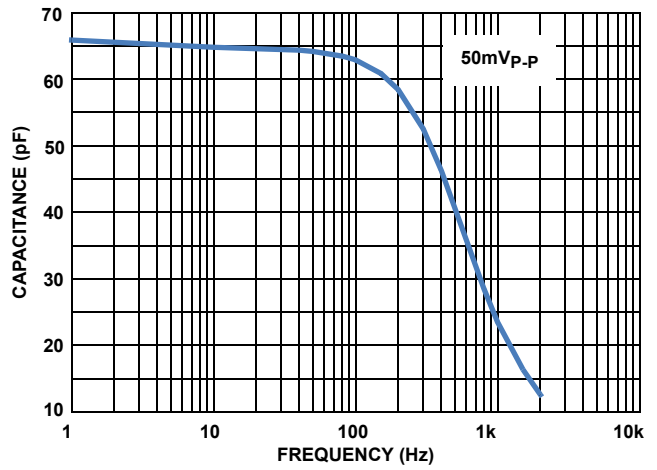

FIGURE 13. SHUNT CAPACITANCE vs FREQUENCY

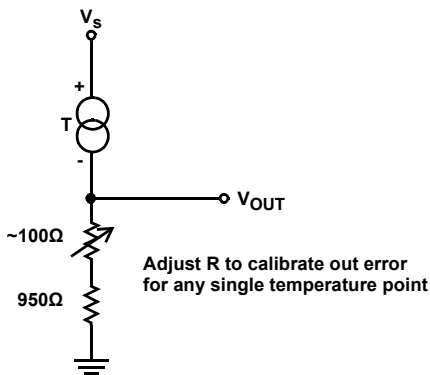

FIGURE 14. SINGLE TEMPERATURE ERROR CALIBRATION

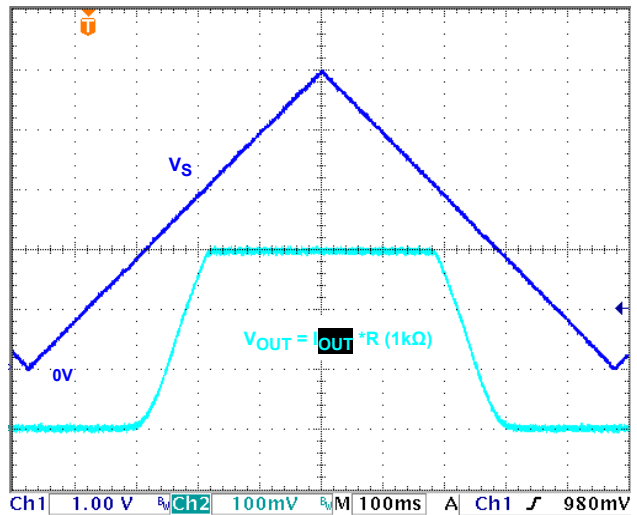

FIGURE 15. TURN-ON/OFF  $V_S$  VOLTAGE

## Typical Performance Curves Unless otherwise specified, $V_S = 5V, T_A = +25^\circ C$ . (Continued)

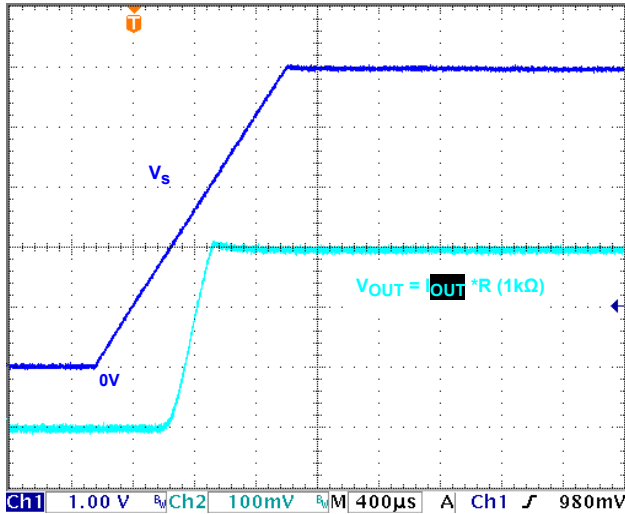

FIGURE 16.  $V_S$  RAMP = 3.7V/ms,  $I_{OUT}$  TURN-ON

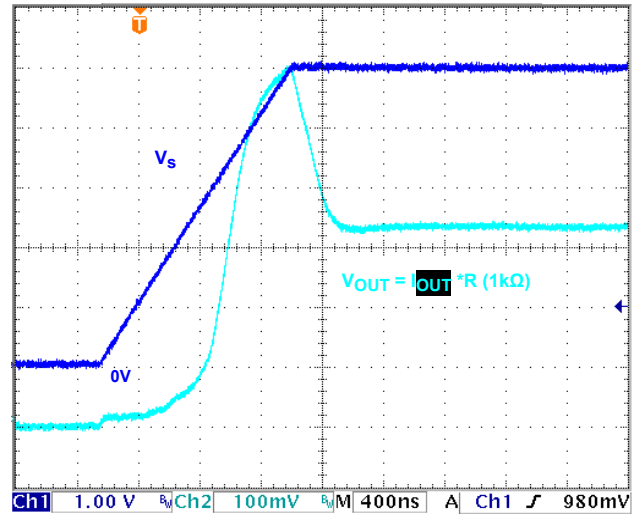

FIGURE 17.  $V_S$  RAMP = 5V/ $\mu$ s,  $I_{OUT}$  TURN-ON

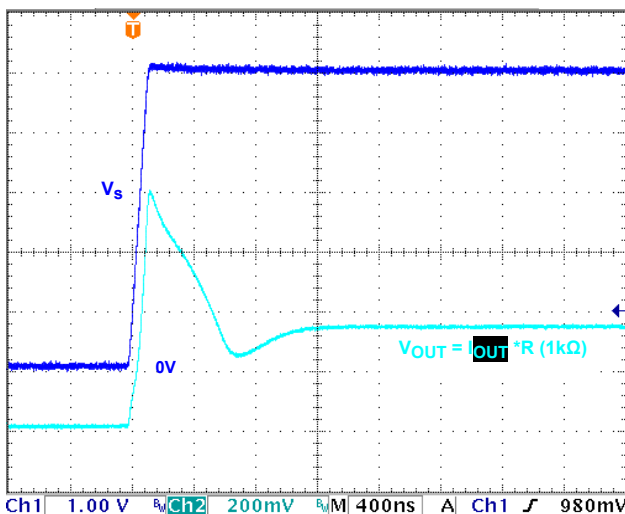

FIGURE 18.  $V_S$  RAMP = 50V/ $\mu$ s,  $I_{OUT}$  TURN-ON

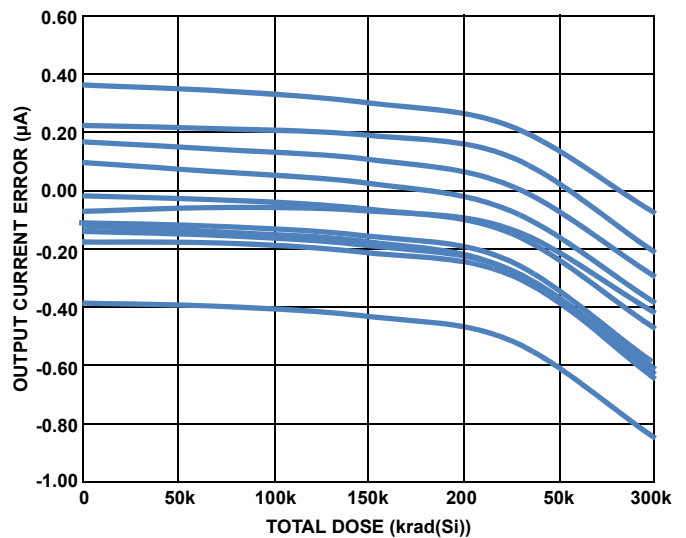

FIGURE 19. TYPICAL ABSOLUTE  $I_{OUT}$  ERROR vs TOTAL IONIZING DOSE FOR HIGH DOSE RATE (ISL71590SEH ONLY)

## Functional Description

### Functional Overview

The ISL71590SEH and ISL73590SEH are integrated-circuit, temperature-to-current transducers, which produce an output current proportional to absolute temperature. The devices act as high impedance constant current regulators passing  $1\mu A/K$  for supply voltages ( $V+$  to  $V-$ ) from +4V to +33V.

The ISL71590SEH is assurance tested at low dose rate to 50krad(Si) and high dose rate to 300krad(Si). The ISL73590SEH is only low dose rate assurance tested to 50krad(Si). Both were SEE characterized at an LET = 86.4MeV • cm<sup>2</sup>/mg.

These devices are manufactured in the Renesas PR40, silicon-on-insulator process, which makes them immune to single event latch-up and provides excellent radiation tolerance. This makes them an ideal choice for high reliability applications in harsh radiation prone environments.

These devices are specified across temperatures of  $-55^\circ C$  to  $+125^\circ C$  without the need for additional circuitry to produce an output within  $\pm 1.7^\circ C$  accuracy. With power requirements as low as 1.5mW (5V at  $+25^\circ C$ ), they are an ideal choice for remote sensing as any length of a well-insulated twisted pair cable will allow for proper operation. The high output impedance ( $>10M\Omega$ ) leaves plenty of room for variations in the power supply voltage. They are electrically durable since they can withstand a forward operating voltage of 33V over the full temperature range with and without ion beam radiation and a reverse voltage of -40V.

These devices should be used in any temperature sensing application from  $-55^{\circ}\text{C}$  to  $+150^{\circ}\text{C}$  in which conventional electrical temperature sensors are currently employed. These devices provide a total temperature sensing solution that is both low in complexity and small in size by eliminating the support circuitry necessary with other thermal sensors such as thermistors, thermocouples, and other discrete-based solutions. External linearization circuitry, precision voltage amplifiers, resistance measuring circuitry, and cold junction compensation are not needed when applying the ISL71590SEH or ISL73590SEH.

In the simplest application, the ISL71590SEH or ISL73590SEH, a resistor, a power source, and any voltmeter can be used to measure temperature. Ideally resistors used should be of a metal film or metal strip type, such resistors having very low thermal coefficient values.

When voltage is initially applied, the circuit becomes active at slightly less than  $4\text{V}$  ( $V_+$  to  $V_-$ ), with  $I_{\text{OUT}}$  ramping up typically  $2\mu\text{s}$  after. There will be an initial short period of time for the  $I_{\text{OUT}}$  to be correctly proportional to the ambient temperature. Depending on the  $V_S$  ramp rate and amplitude, this may take a few  $\mu\text{s}$  before a reliable temperature reading is available. See [Figures 15](#) through [18](#) for scope shot examples.

The output characteristics also make the ISL71590SEH or ISL73590SEH easy to multiplex; with either or both the input supply voltage or the output current can be switched by a CMOS multiplexer such as the HS-508 or HS-1840 from Renesas.

When the die product is used, the die substrate should be tied to the more negative of the two terminals for optimum performance.

## Parameter Glossary

The parametric specifications provide for an understanding of the temperature sensor performance over-temperature and radiation exposure. Following are critical parameter explanations as they relate to usage and interpretation.

**Ambient Error Accuracy** refers to the maximum error at an ambient temperature of  $+25^{\circ}\text{C}$  and is expressed as  $\pm 0.5^{\circ}\text{C}$  of the **Nominal Current Output** at  $+25^{\circ}\text{C}$  (298.15K) of  $298.15\mu\text{A}$ .

The **Absolute Error without External Calibration** describes the temperature accuracy over the entire  $-55^{\circ}\text{C}$  to  $+125^{\circ}\text{C}$  range.

The typical performance is shown in [Figure 8 on page 5](#). Both of these two first specification explanations are to be considered as initial error accuracy specifications.

The **Post Radiation Ambient Error ( $E_{\text{RADD}}$ )** is the specified accuracy after  $50\text{krad}(\text{Si})$  at  $0.01\text{rad}(\text{Si})$  per second (LDR) and  $300\text{krad}(\text{Si})$  at  $70\text{rad}(\text{Si})$  per second (HDR) exposure. This radiation hardness performance is unmatched in the industry for this class of device. This performance is shown in [Figure 2 on page 1](#) as a delta over radiation type and in [Figure 19 on page 7](#) as an absolute measurement.

**Nonlinearity**, in reference to these devices, is the maximum allowable deviation of the output current over-temperature for any single part relative to its individual best fit line over five discrete temperature points ( $-55^{\circ}\text{C}$ ,  $-15^{\circ}\text{C}$ ,  $+25^{\circ}\text{C}$ ,  $+85^{\circ}\text{C}$ ,  $+125^{\circ}\text{C}$ ). This performance is assured by testing.

**Repeatability Errors** arise from a strain hysteresis of the package. For the ISL71590SEH and ISL73590SEH this is the maximum deviation between  $+25^{\circ}\text{C}$  readings after a single temperature excursion between  $-55^{\circ}\text{C}$  and  $+125^{\circ}\text{C}$ , and is assured by characterization and is not tested. The magnitude of this error is solely a function of the magnitude of the temperature span and duration over which the device is exposed.

**Long Term Drift Errors** are related to the average operating temperature and the magnitude of the thermal shocks experienced by the device. Extended use of the ISL7x590SEH temperatures at  $+125^{\circ}\text{C}$  typically results in long-term drift of  $-0.05^{\circ}\text{C}$  after 1khr with a specification of  $-0.25^{\circ}\text{C}$  to  $+0.25^{\circ}\text{C}$ .

## Trimming Out Errors

The ideal graph of current versus temperature for the ISL7x590SEH is a straight line, but as [Figure 20 on page 9](#) shows, the actual shape is slightly different (exaggerated greatly for explanation). Since the sensor is limited to the range of  $-55^{\circ}\text{C}$  to  $+150^{\circ}\text{C}$ , it is possible to optimize the accuracy by trimming. Trimming extracts the maximum performance from the sensor.

The circuit in [Figure 21 on page 9](#) trims the slope of the ISL71590SEH output. The effect of this is shown in [Figure 22 on page 9](#).

The circuit of [Figure 23 on page 9](#) trims both the slope and the offset. Starting in [Figure 24 on page 9](#) with an untrimmed slope, then progressing through to [Figure 27 on page 10](#), each figure shows the effect of adjusting the offset and slope and finally, the offset again, to arrive at an optimized condition.

The diagrams' curvatures are highly exaggerated to show effects, but it should be clear that these trims can be used to minimize errors over a partial or the entire temperature range.



## Trimming Out Errors

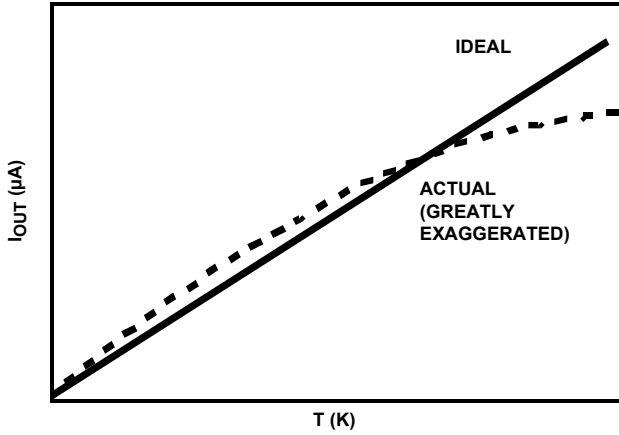

FIGURE 20. TRIMMING OUT ERRORS

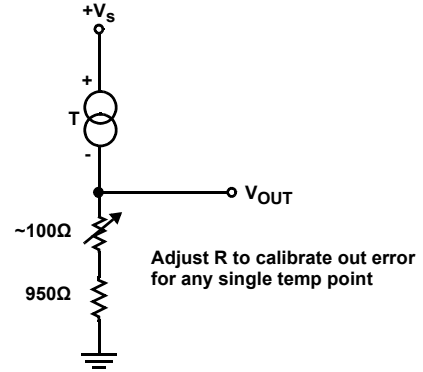

FIGURE 21. SLOPE TRIMMING

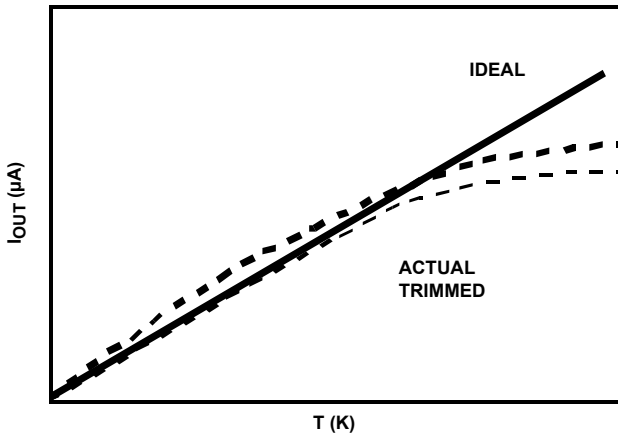

FIGURE 22. EFFECT OF SLOPE TRIM

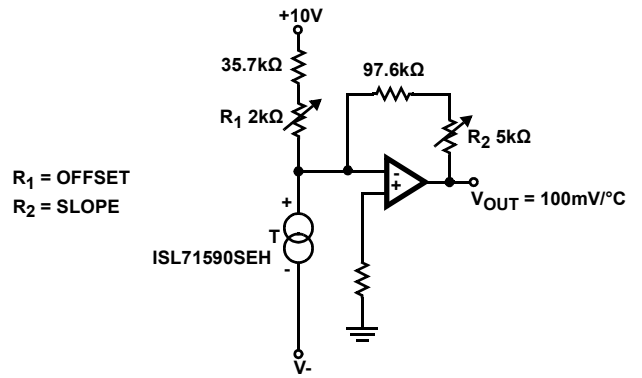

FIGURE 23. SLOPE AND OFFSET TRIMMING

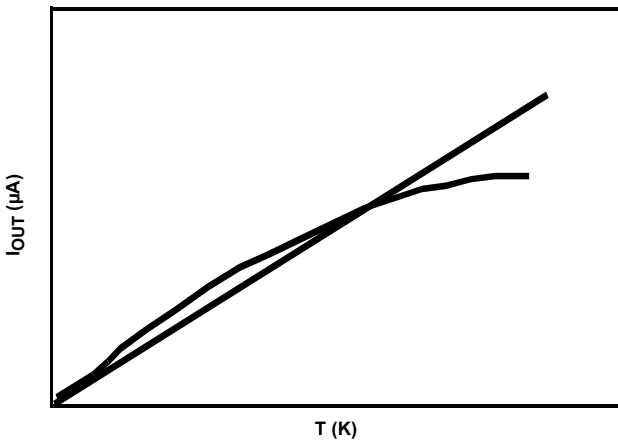

FIGURE 24. UNTRIMMED

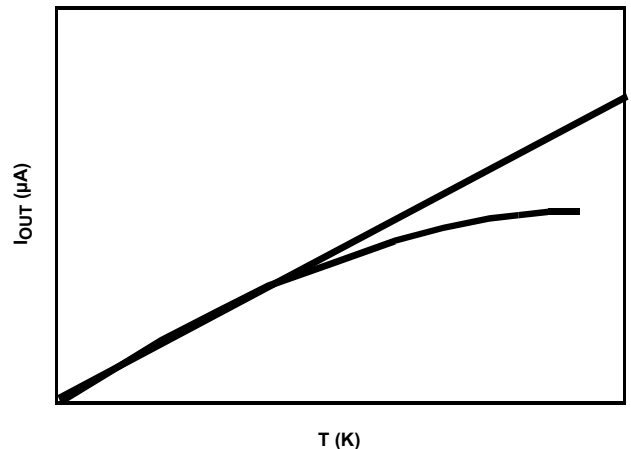

FIGURE 25. TRIM ONE: OFFSET

## Trimming Out Errors (Continued)

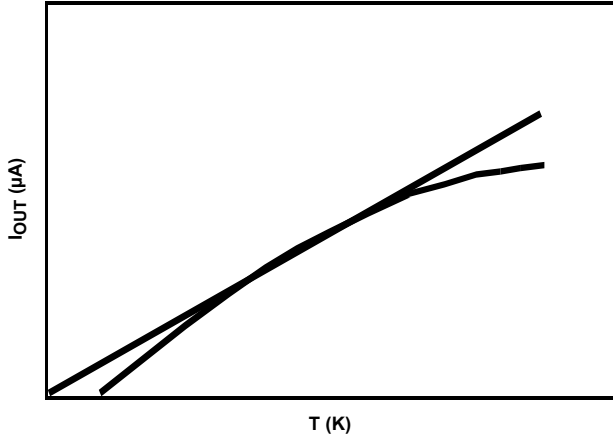

FIGURE 26. TRIM TWO: SLOPE

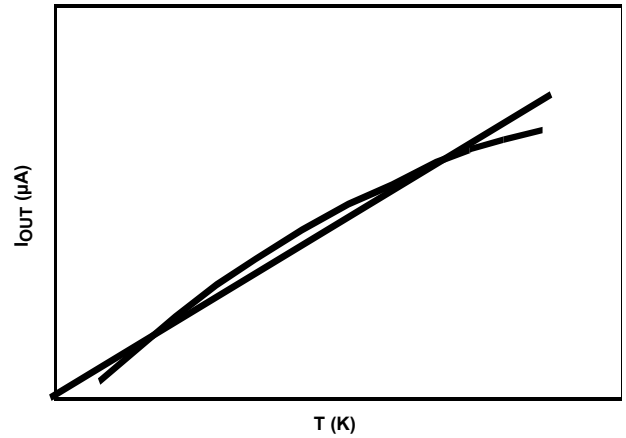

FIGURE 27. TRIM THREE: OFFSET AGAIN

## Typical Applications

The following section of the datasheet illustrates several application ideas, touching on each with a short explanation. All of this material is applicable to both the ISL71590SEH and the ISL73590SEH devices.

There is an evaluation board ISL71590SEHEV1Z and accompanying user guide "[ISL71590SEH Evaluation Board User's Guide](#)" that details four of the more fundamental implementations of this device.

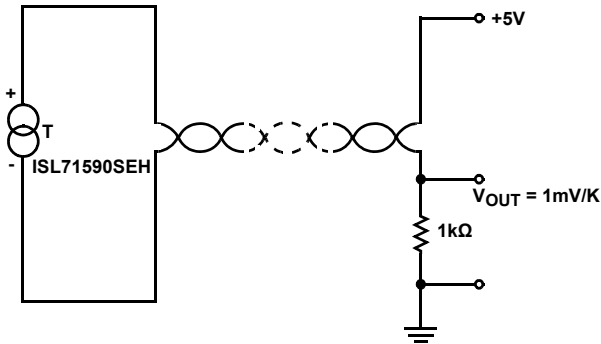

FIGURE 28. TYPICAL APPLICATION

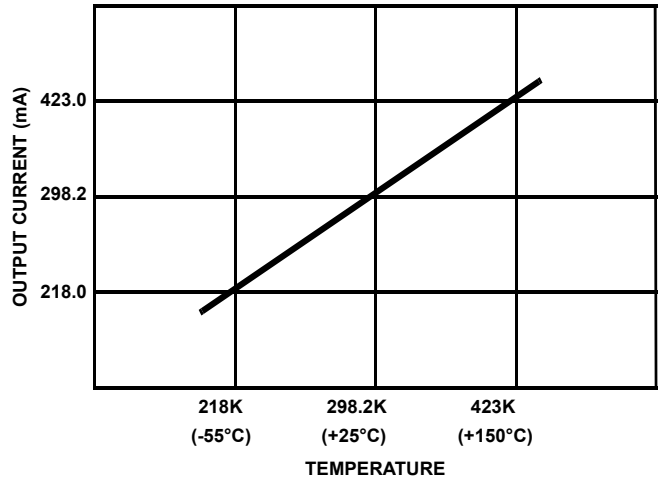

FIGURE 29. SIMPLE CONNECTION. OUTPUT IS PROPORTIONAL TO ABSOLUTE TEMPERATURE

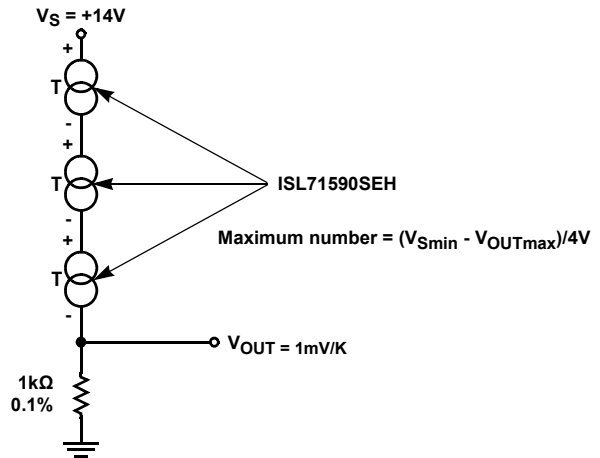
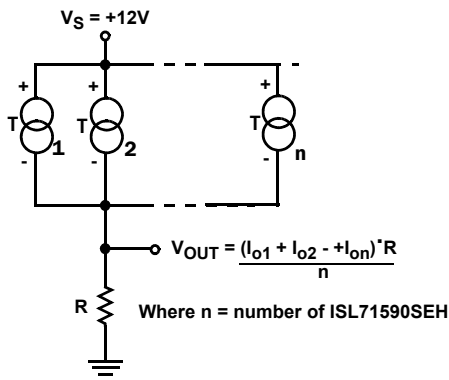
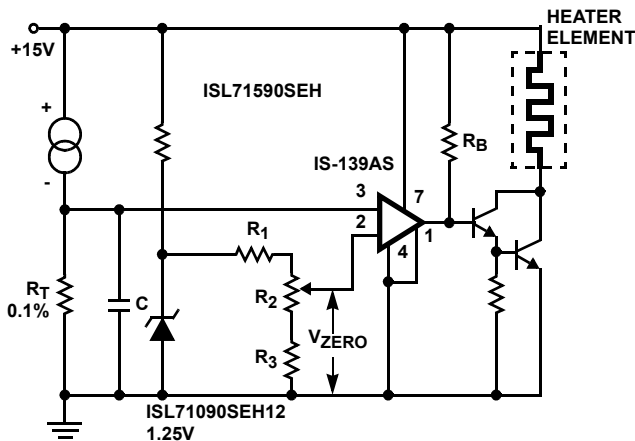

FIGURE 30. LOWEST TEMPERATURE SENSING SCHEME. OUTPUT CURRENT IS THAT OF THE "COLDEST" SENSOR



(e.g., with four sensors and R = 250Ω V<sub>OUT</sub> = 1mV/K)  
**FIGURE 31. AVERAGE TEMPERATURE SENSING SCHEME**

The sum of the ISL71590SEH currents appears across R, which represents the average temperature in the sensor array (see [Figure 31](#)).



**FIGURE 32. SINGLE SETPOINT TEMPERATURE CONTROLLER**

In [Figure 32](#), the ISL71590SEH produces a temperature-dependent voltage across R<sub>T</sub> (C is for filtering noise). Setting R<sub>2</sub> produces a scale-zero voltage. For the Celsius scale, make R<sub>T</sub> = 1kΩ and V<sub>ZERO</sub> = 0.273V. For Fahrenheit, R<sub>T</sub> = 1.8kΩ and V<sub>ZERO</sub> = 0.460V.

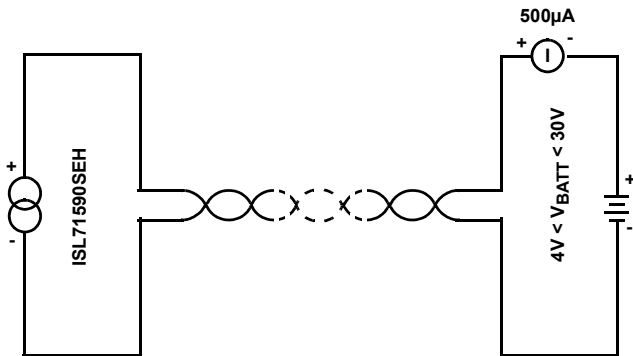

**FIGURE 33. SIMPLEST THERMOMETER**

[Figure 33](#), illustrates the simplest thermometer displaying current output directly in Kelvin. Using the ISL71590SEH, sensor output is within ±1.7K over the entire range.

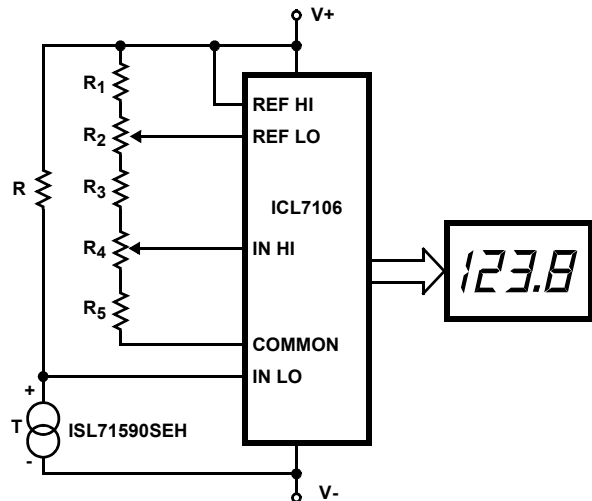

**FIGURE 34. BASIC DIGITAL THERMOMETER, CELSIUS, AND FAHRENHEIT SCALES**

**TABLE 3.**

	R	R <sub>1</sub>	R <sub>2</sub>	R <sub>3</sub>	R <sub>4</sub>	R <sub>5</sub>
°F	9.00	4.02	2.0	12.4	10.0	0
°C	5.00	4.02	2.0	5.11	5.0	11.8

$$\sum_{n=1}^5 R_n = 28\text{k}\Omega \text{ nominal} \quad (\text{EQ. 1})$$

NOTE: ALL values are in kΩ.

In [Figure 34](#), the ICL7106 has a V<sub>IN</sub> span of ±2.0V and a V<sub>CM</sub> range of (V<sub>+</sub> - 0.5V) to (V<sub>-</sub> + 1V). R is scaled to bring each range within V<sub>CM</sub> while not exceeding V<sub>IN</sub>. The V<sub>REF</sub> for both scales is 500mV, maximum reading on the Celsius range is +150°C limited by the maximum allowable sensor temperature. Maximum reading on the Fahrenheit range is +199.9°F (+93.3°C) limited by the number of display digits.

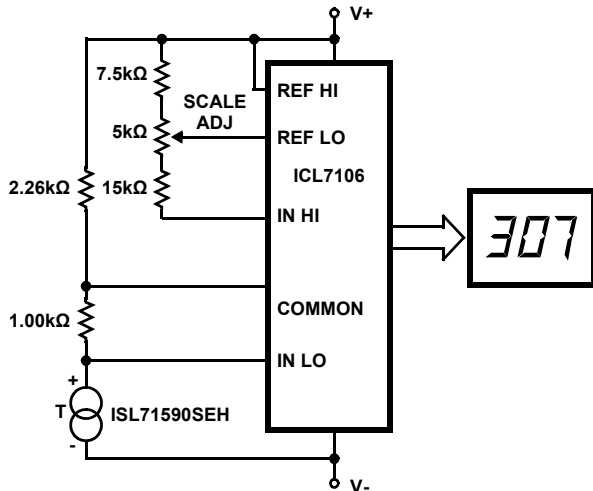

FIGURE 35. BASIC DIGITAL THERMOMETER, KELVIN SCALE

Figure 35, illustrates the Kelvin scale version reading from 0 to 1999K theoretically, and from 223K to 473K actually. The 2.26kΩ resistor brings the input within the ICL7106  $V_{CM}$  range. Two general-purpose silicon diodes or an LED may be substituted.

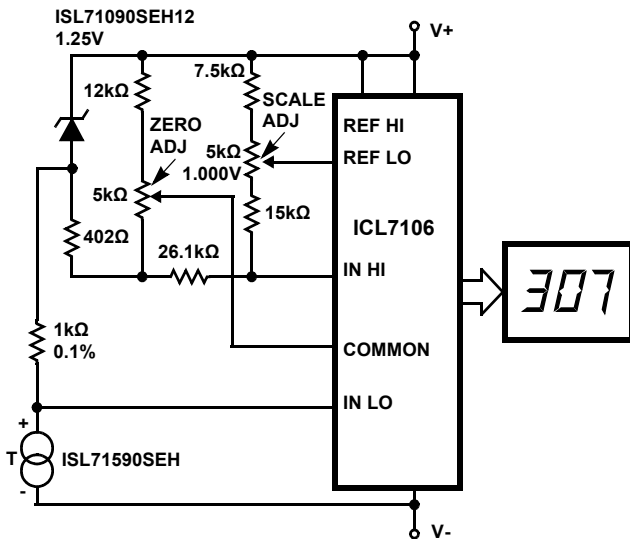

FIGURE 36. BASIC DIGITAL THERMOMETER, KELVIN SCALE WITH ZERO ADJUST

The circuit in Figure 36 allows “zero adjustment” as well as slope adjustment. The ISL71090SEH12 brings the input within the common-mode range, while the 5kΩ pots trim any offset at 218K (-55°C) and set the scale factor.

Since all three scales have narrow  $V_{IN}$  spans, some optimization of the ICL7106 components can be made to lower noise and preserve CMR. Table 4 shows the suggested values. Similar scaling can be used with the ICL7126 and ICL7136 (see Figures 34 through 36).

TABLE 4.

SCALE	$V_{IN}$ RANGE (V)	RINT (kΩ)	CAZ (μF)
K	0.223 to 0.473	220	0.47
C	-0.25 to +1.0	220	0.1
F	-0.29 to +0.996	220	0.1

FOR ALL:  
 $C_{REF} = 0.1\mu F$   
 $C_{INT} = 0.22\mu F$   
 $C_{OSC} = 100pF$   
 $R_{OSC} = 100k\Omega$

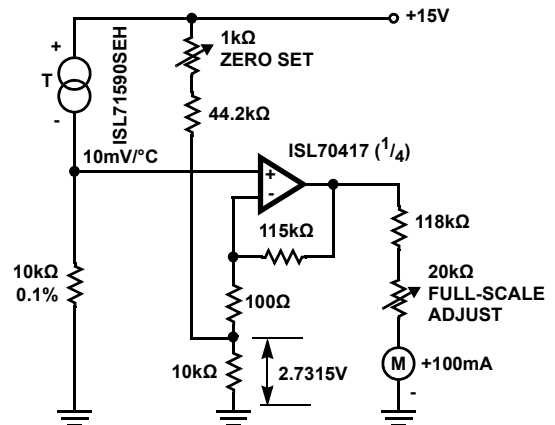

FIGURE 37. CENTIGRADE THERMOMETER (0°C TO +100°C)

Figure 37 illustrates the low bias current of the ISL70417, which allows the use of large value gain resistors and keeps the meter current error under 0.5%, therefore saving the expense of an extra meter driving amplifier.

Figure 38 shows a differential temperature sensing circuit configuration. The 50kΩ pot trims offset in the devices whether internal or external, so it can be used to set the size of the difference interval. This also makes it useful for liquid level detection where there will be a measurable temperature difference.

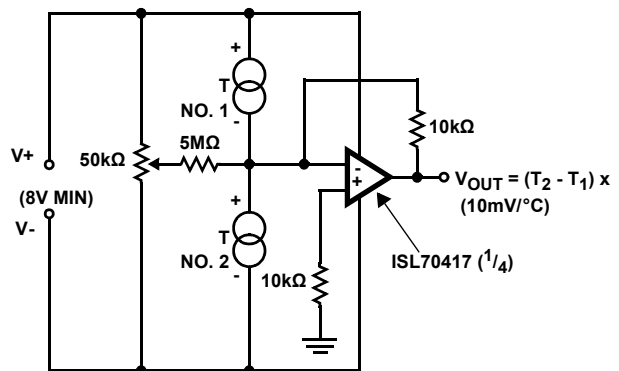

FIGURE 38. DIFFERENTIAL THERMOMETER

In [Figure 39](#) the reference junction(s) should be in close thermal contact with the ISL71590SEH case. V+ must be be at least 4V, while ISL71090SEH12 current should be set 1mA to 2mA. Calibration does not require shorting or removal of the thermocouple: set R<sub>1</sub> for V<sub>2</sub> = 10.98mV. If very precise measurements are needed, adjust R<sub>2</sub> to the exact

Seebeck coefficient for the thermocouple used (measured or from table) note V<sub>1</sub>, and set R<sub>1</sub> to buck out this voltage (i.e., set V<sub>2</sub> = V<sub>1</sub>). For other thermocouple types, adjust values to the appropriate Seebeck coefficient.

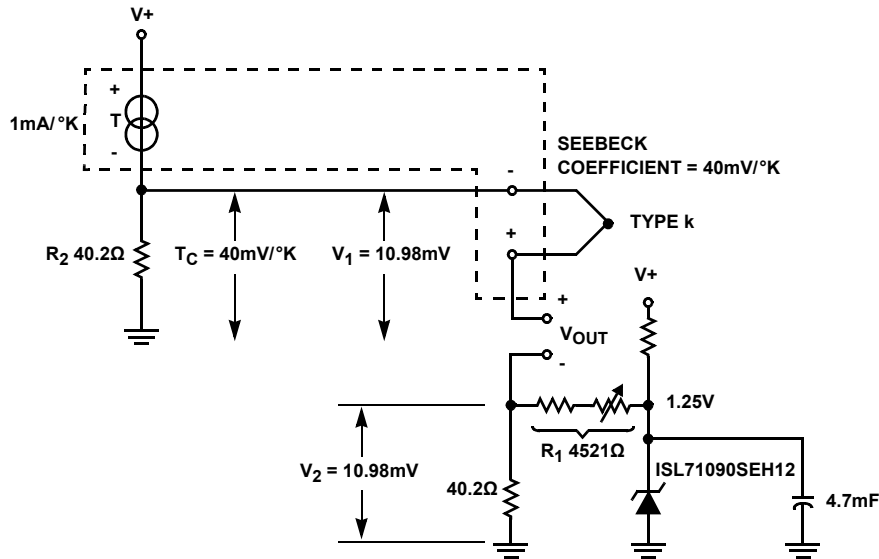

FIGURE 39. COLD JUNCTION COMPENSATION FOR TYPE K THERMOCOUPLE

## Package Characteristics

### Weight of Packaged Device

0.07 Grams (typical)

### Lid Characteristics

Finish: Gold

Potential: Floating

Case Isolation to Any Lead:  $10 \times 10^9 \Omega$  (minimum)

## Die Characteristics

### Die Dimensions

1185 $\mu\text{m}$  x 1695 $\mu\text{m}$  (46.7 mils x 66.7 mils)

Thickness: 254 $\mu\text{m}$   $\pm$ 25.4 $\mu\text{m}$  (10 mils  $\pm$ 1 mil)

### Interface Materials

#### GLASSIVATION

Type: Nitrox

Thickness: 15k $\text{Å}$

### TOP METALLIZATION

Type: AlCu (99.5%/0.5%)

Thickness: 30k $\text{Å}$

### BACKSIDE FINISH

Silicon

## ASSEMBLY RELATED INFORMATION

### SUBSTRATE POTENTIAL

Tied to V- pin

## ADDITIONAL INFORMATION

### WORST CASE CURRENT DENSITY

$< 5 \times 10^3 \text{A/cm}^2$

### PROCESS

Dielectrically Isolated Bipolar SOI - PR40

### TRANSISTOR COUNT

92

## Metallization Mask Layout

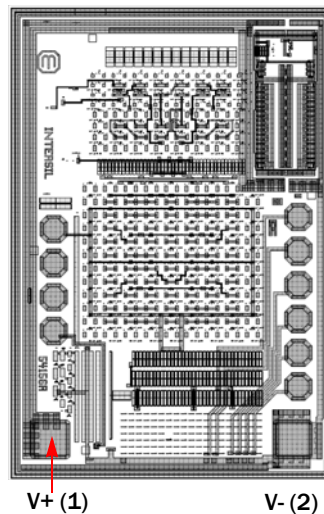

TABLE 5.

PAD NAME	PIN NUMBER	X ( $\mu\text{m}$ )	Y ( $\mu\text{m}$ )	$\Delta\text{X}$ ( $\mu\text{m}$ )	$\Delta\text{Y}$ ( $\mu\text{m}$ )	BOND WIRES PER PAD
V+	1	0	0	110	110	1
V-	2	823	0	110	110	1

NOTES:

- 11. Origin of coordinates is the centroid of pad 1.
- 12. Bond wire size is 1.25 mil.

**Revision History** The revision history provided is for informational purposes only and is believed to be accurate, but not warranted. Please visit our website to make sure you have the latest revision.

DATE	REVISION	CHANGE
Sep 14, 2018	FN8376.3	Added Table 1 on page 1. Updated Related Literature section. Added ISL73590SEH information throughout document. Added Notes 3 and 4. Applied new Header/Footer. Removed About Intersil. Updated Disclaimer.
Jun 3, 2016	FN8376.2	Clarified minimum differential voltage throughout document. Replaced figures 5 and 6.
Jan 19, 2016	FN8376.1	Removed Pb-Free Reflow reference from "Thermal Information" on page 4 as it is not applicable to hermetic packages. In "Electrical Specifications" on page 4: -Updated EA maximum and minimum limits. -Updated ERADD Low Dose minimum limits. -Updated ERADD High Dose minimum limits. Updated About Intersil Section.
Sep 26, 2013	FN8376.0	Initial Release

# Package Outline Drawing

For the most recent package outline drawing, see [K2.A](#).

## K2.A

### 2 LEAD CERAMIC METAL SEAL FLATPACK PACKAGE

Rev 1, 4/12

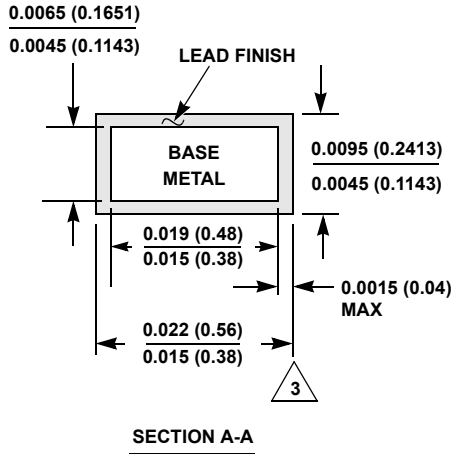
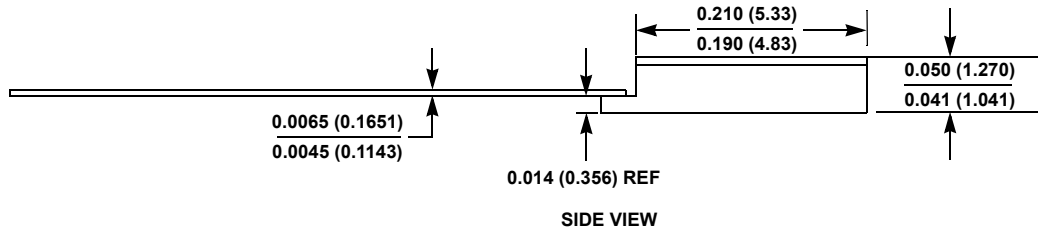
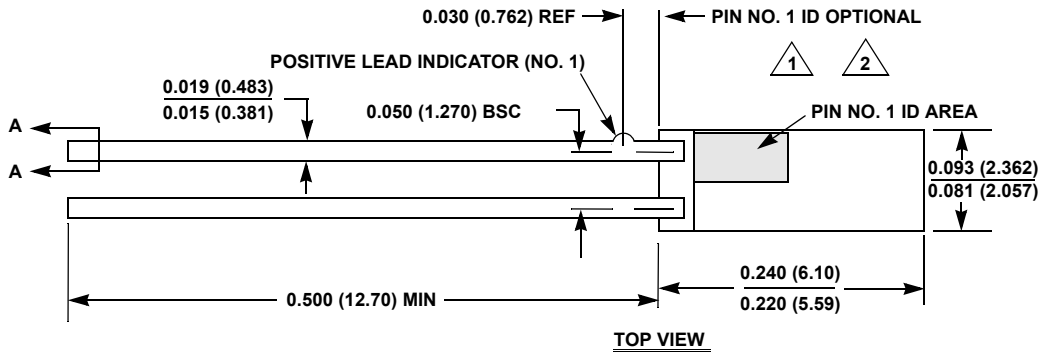

**NOTES:**

1. Index area: A notch or a pin one identification mark shall be located adjacent to pin one and shall be located within the shaded area shown. The manufacturer's identification shall not be used as a pin one identification mark. Alternately, a tab may be used to identify pin one.
2. If a pin one identification mark is used in addition to a tab, the limits of the tab dimension do not apply.
3. The maximum limits of lead dimensions (section A-A) shall be measured at the centroid of the finished lead surfaces, when solder dip or tin plate lead finish is applied.
4. Dimensioning and tolerancing conform to ANSI Y14.5M-1982.
5. Dimensions: Inch (mm). Controlling dimension: Inch.



## Notice

1. Descriptions of circuits, software and other related information in this document are provided only to illustrate the operation of semiconductor products and application examples. You are fully responsible for the incorporation or any other use of the circuits, software, and information in the design of your product or system. Renesas Electronics disclaims any and all liability for any losses and damages incurred by you or third parties arising from the use of these circuits, software, or information.
2. Renesas Electronics hereby expressly disclaims any warranties against and liability for infringement or any other claims involving patents, copyrights, or other intellectual property rights of third parties, by or arising from the use of Renesas Electronics products or technical information described in this document, including but not limited to, the product data, drawings, charts, programs, algorithms, and application examples.
3. No license, express, implied or otherwise, is granted hereby under any patents, copyrights or other intellectual property rights of Renesas Electronics or others.
4. You shall not alter, modify, copy, or reverse engineer any Renesas Electronics product, whether in whole or in part. Renesas Electronics disclaims any and all liability for any losses or damages incurred by you or third parties arising from such alteration, modification, copying or reverse engineering.
5. Renesas Electronics products are classified according to the following two quality grades: "Standard" and "High Quality". The intended applications for each Renesas Electronics product depends on the product's quality grade, as indicated below.  
"Standard": Computers; office equipment; communications equipment; test and measurement equipment; audio and visual equipment; home electronic appliances; machine tools; personal electronic equipment; industrial robots; etc.  
"High Quality": Transportation equipment (automobiles, trains, ships, etc.); traffic control (traffic lights); large-scale communication equipment; key financial terminal systems; safety control equipment; etc.  
Unless expressly designated as a high reliability product or a product for harsh environments in a Renesas Electronics data sheet or other Renesas Electronics document, Renesas Electronics products are not intended or authorized for use in products or systems that may pose a direct threat to human life or bodily injury (artificial life support devices or systems; surgical implantations; etc.), or may cause serious property damage (space system; undersea repeaters; nuclear power control systems; aircraft control systems; key plant systems; military equipment; etc.). Renesas Electronics disclaims any and all liability for any damages or losses incurred by you or any third parties arising from the use of any Renesas Electronics product that is inconsistent with any Renesas Electronics data sheet, user's manual or other Renesas Electronics document.
6. When using Renesas Electronics products, refer to the latest product information (data sheets, user's manuals, application notes, "General Notes for Handling and Using Semiconductor Devices" in the reliability handbook, etc.), and ensure that usage conditions are within the ranges specified by Renesas Electronics with respect to maximum ratings, operating power supply voltage range, heat dissipation characteristics, installation, etc. Renesas Electronics disclaims any and all liability for any malfunctions, failure or accident arising out of the use of Renesas Electronics products outside of such specified ranges.
7. Although Renesas Electronics endeavors to improve the quality and reliability of Renesas Electronics products, semiconductor products have specific characteristics, such as the occurrence of failure at a certain rate and malfunctions under certain use conditions. Unless designated as a high reliability product or a product for harsh environments in a Renesas Electronics data sheet or other Renesas Electronics document, Renesas Electronics products are not subject to radiation resistance design. You are responsible for implementing safety measures to guard against the possibility of bodily injury, injury or damage caused by fire, and/or danger to the public in the event of a failure or malfunction of Renesas Electronics products, such as safety design for hardware and software, including but not limited to redundancy, fire control and malfunction prevention, appropriate treatment for aging degradation or any other appropriate measures. Because the evaluation of microcomputer software alone is very difficult and impractical, you are responsible for evaluating the safety of the final products or systems manufactured by you.
8. Please contact a Renesas Electronics sales office for details as to environmental matters such as the environmental compatibility of each Renesas Electronics product. You are responsible for carefully and sufficiently investigating applicable laws and regulations that regulate the inclusion or use of controlled substances, including without limitation, the EU RoHS Directive, and using Renesas Electronics products in compliance with all these applicable laws and regulations. Renesas Electronics disclaims any and all liability for damages or losses occurring as a result of your noncompliance with applicable laws and regulations.
9. Renesas Electronics products and technologies shall not be used for or incorporated into any products or systems whose manufacture, use, or sale is prohibited under any applicable domestic or foreign laws or regulations. You shall comply with any applicable export control laws and regulations promulgated and administered by the governments of any countries asserting jurisdiction over the parties or transactions.
10. It is the responsibility of the buyer or distributor of Renesas Electronics products, or any other party who distributes, disposes of, or otherwise sells or transfers the product to a third party, to notify such third party in advance of the contents and conditions set forth in this document.
11. This document shall not be reprinted, reproduced or duplicated in any form, in whole or in part, without prior written consent of Renesas Electronics.
12. Please contact a Renesas Electronics sales office if you have any questions regarding the information contained in this document or Renesas Electronics products.

(Note 1) "Renesas Electronics" as used in this document means Renesas Electronics Corporation and also includes its directly or indirectly controlled subsidiaries.

(Note 2) "Renesas Electronics product(s)" means any product developed or manufactured by or for Renesas Electronics.

(Rev.4.0-1 November 2017)



### SALES OFFICES

Renesas Electronics Corporation

<http://www.renesas.com>

Refer to "<http://www.renesas.com/>" for the latest and detailed information.

#### Renesas Electronics Corporation

TOYOSU FORESIA, 3-2-24 Toyosu, Koto-ku, Tokyo 135-0061, Japan

#### Renesas Electronics America Inc.

1001 Murphy Ranch Road, Milpitas, CA 95035, U.S.A.  
Tel: +1-408-432-8888, Fax: +1-408-434-5351

#### Renesas Electronics Canada Limited

9251 Yonge Street, Suite 8309 Richmond Hill, Ontario Canada L4C 9T3  
Tel: +1-905-237-2004

#### Renesas Electronics Europe Limited

Dukes Meadow, Millboard Road, Bourne End, Buckinghamshire, SL8 5FH, U.K  
Tel: +44-1628-651-700

#### Renesas Electronics Europe GmbH

Arcadiastrasse 10, 40472 Düsseldorf, Germany  
Tel: +49-211-6503-0, Fax: +49-211-6503-1327

#### Renesas Electronics (China) Co., Ltd.

Room 1709 Quantum Plaza, No.27 ZhichunLu, Haidian District, Beijing, 100191 P. R. China  
Tel: +86-10-8235-1155, Fax: +86-10-8235-7679

#### Renesas Electronics (Shanghai) Co., Ltd.

Unit 301, Tower A, Central Towers, 555 Langao Road, Putuo District, Shanghai, 200333 P. R. China  
Tel: +86-21-2226-0888, Fax: +86-21-2226-0999

#### Renesas Electronics Hong Kong Limited

Unit 1601-1611, 16/F., Tower 2, Grand Century Place, 193 Prince Edward Road West, Mongkok, Kowloon, Hong Kong  
Tel: +852-2265-6688, Fax: +852 2886-9022

#### Renesas Electronics Taiwan Co., Ltd.

13F, No. 363, Fu Shing North Road, Taipei 10543, Taiwan  
Tel: +886-2-8175-9600, Fax: +886 2-8175-9670

#### Renesas Electronics Singapore Pte. Ltd.

80 Bendemeer Road, Unit #06-02 Hyflux Innovation Centre, Singapore 339949  
Tel: +65-6213-0200, Fax: +65-6213-0300

#### Renesas Electronics Malaysia Sdn.Bhd.

Unit 1207, Block B, Menara Amcorp, Amcorp Trade Centre, No. 18, Jin Persiaran Barat, 46050 Petaling Jaya, Selangor Darul Ehsan, Malaysia  
Tel: +60-3-7955-9390, Fax: +60-3-7955-9510

#### Renesas Electronics India Pvt. Ltd.

No.777C, 100 Feet Road, HAL 2nd Stage, Indiranagar, Bangalore 560 038, India  
Tel: +91-80-67208700, Fax: +91-80-67208777

#### Renesas Electronics Korea Co., Ltd.

17F, KAMCO Yangjae Tower, 262, Gangnam-daero, Gangnam-gu, Seoul, 06265 Korea  
Tel: +82-2-558-3737, Fax: +82-2-558-5338