

Designing Printed Antennas for Bluetooth Low Energy

Guidelines for designing printed antennas for 2.4 GHz Bluetooth® low energy applications on single-layer and multi-layer PCB stack-ups.

Contents

Contents	1
Figures	2
1. Terms and Definitions	3
2. Introduction	3
3. RF Layout Design	4
3.1 Radio IC	4
3.2 RF Transmission Lines, Filters, and Matching Networks	5
3.3 Antennas, General Considerations	5
4. Antennas on Multi-Layer Substrates	6
4.1 Full Size Printed IFA, 1 mm Substrate	7
4.1.1 Matching Network	8
4.1.2 Measured Return Loss	8
4.1.3 Measured Radiation Pattern	9
4.2 Reduced Size Printed IFA, 1 mm Substrate, Variant 1	10
4.2.1 Matching Network	11
4.2.2 Measured Return Loss	11
4.2.3 Measured Radiation Pattern	12
4.3 Reduced Size Printed IFA, 1 mm Substrate, Variant 2	13
4.3.1 Matching Network	14
4.3.2 Measured Return Loss	14
4.3.3 Measured Radiation Pattern	15
4.4 ZOR Antenna, 1.6 mm Substrate	16
4.4.1 Matching Network	17
4.4.2 Measured Return Loss	17
4.4.3 Measured Radiation Pattern	18
4.5 ZOR Antenna, 1.0 mm Substrate	19
4.5.1 Matching Network	20
4.5.2 Measured Return Loss	20
4.5.3 Measured Radiation Pattern	21
5. Antennas on Single Layer Substrates	22
5.1 Carbon Layers	22
5.2 Single Layer Printed IFA, 1 mm Substrate	23
5.2.1 Matching Network	24
5.2.2 Measured Return Loss	24
5.2.3 Measured Radiation Pattern	25
6. Conclusions	26

7. Revision History27

Figures

Figure 1. DA1458x_CB_PXI_WLCSP board layout snapshot4
Figure 2. Placement of filters and matching networks5
Figure 3. Full size IFA with dimensions7
Figure 4. Matching components, full size IFA8
Figure 5. Measured S11, full size IFA8
Figure 6. Radiation pattern, PCB horizontal, full size IFA9
Figure 7. Radiation pattern, PCB vertical, full size IFA9
Figure 8. Reduced size IFA, variant 110
Figure 9. Matching components, reduced size IFA, variant 111
Figure 10. Measured S11, reduced size IFA, variant 111
Figure 11. Radiation pattern, PCB horizontal, reduced size IFA, variant 112
Figure 12. Radiation pattern, PCB vertical, reduced size IFA, variant 112
Figure 13. Reduced size IFA, variant 213
Figure 14. Matching components, reduced size IFA, variant 214
Figure 15. Measured S11, reduced size IFA, variant 214
Figure 16. Radiation pattern, PCB horizontal, reduced size IFA, variant 215
Figure 17. Radiation pattern, PCB vertical, reduced size IFA, variant 215
Figure 18. ZOR antenna preview16
Figure 19. Matching components, ZOR antenna, 1.6 mm substrate17
Figure 20. Measured S11, ZOR antenna, 1.6 mm substrate17
Figure 21. Radiation pattern, DUT horizontal, ZOR antenna, 1.6 mm substrate18
Figure 22. Radiation pattern, DUT vertical, ZOR antenna, 1.6 mm substrate18
Figure 23. ZOR antenna preview19
Figure 24. Matching components, ZOR antenna, 1.0 mm substrate20
Figure 25. Measured S11, ZOR antenna, 1.0 mm substrate20
Figure 26. Radiation pattern, DUT horizontal, ZOR antenna, 1.0 mm substrate21
Figure 27. Radiation pattern, DUT vertical, ZOR antenna, 1.0 mm substrate21
Figure 28. Single layer IFA23
Figure 29. Matching components, single layer IFA24
Figure 30. Measured S11, single layer IFA24
Figure 31. Radiation pattern, PCB horizontal, single layer IFA25
Figure 32. Radiation pattern, PCB vertical, single layer IFA25

1. Terms and Definitions

Balun	balanced/unbalanced (transformer)
Bluetooth® LE	Bluetooth Low Energy
DNP	Do Not Populate
GND	Ground (plane)
IC	Integrated Circuit
IFA	Inverted-F Antenna
PCB	Printed Circuit Board
RF	Radio Frequency
XTAL	(Quartz) Crystal
ZOR	Zeroth-Order Resonance (antenna)

2. Introduction

This application note contains guidelines for implementing printed PCB antennas for Bluetooth® low energy applications operating in the 2.4 GHz frequency band. Basic rules are given on what to avoid when starting with an antenna design.

For multi-layer PCBs several antenna options are given, depending on the available PCB space. There is a trade-off between antenna size and radiation performance. Full size antennas are more broadband and easier to match since the impedance is closer to 50 Ω.

For single-layer PCBs the main challenge is providing a proper ground (GND) plane for the antenna. When a lower quality substrate material is used to reduce cost, this also has an impact on the radiation efficiency of the antenna.

3. RF Layout Design

This section provides guidelines you should consider for general RF layout work.

3.1 Radio IC

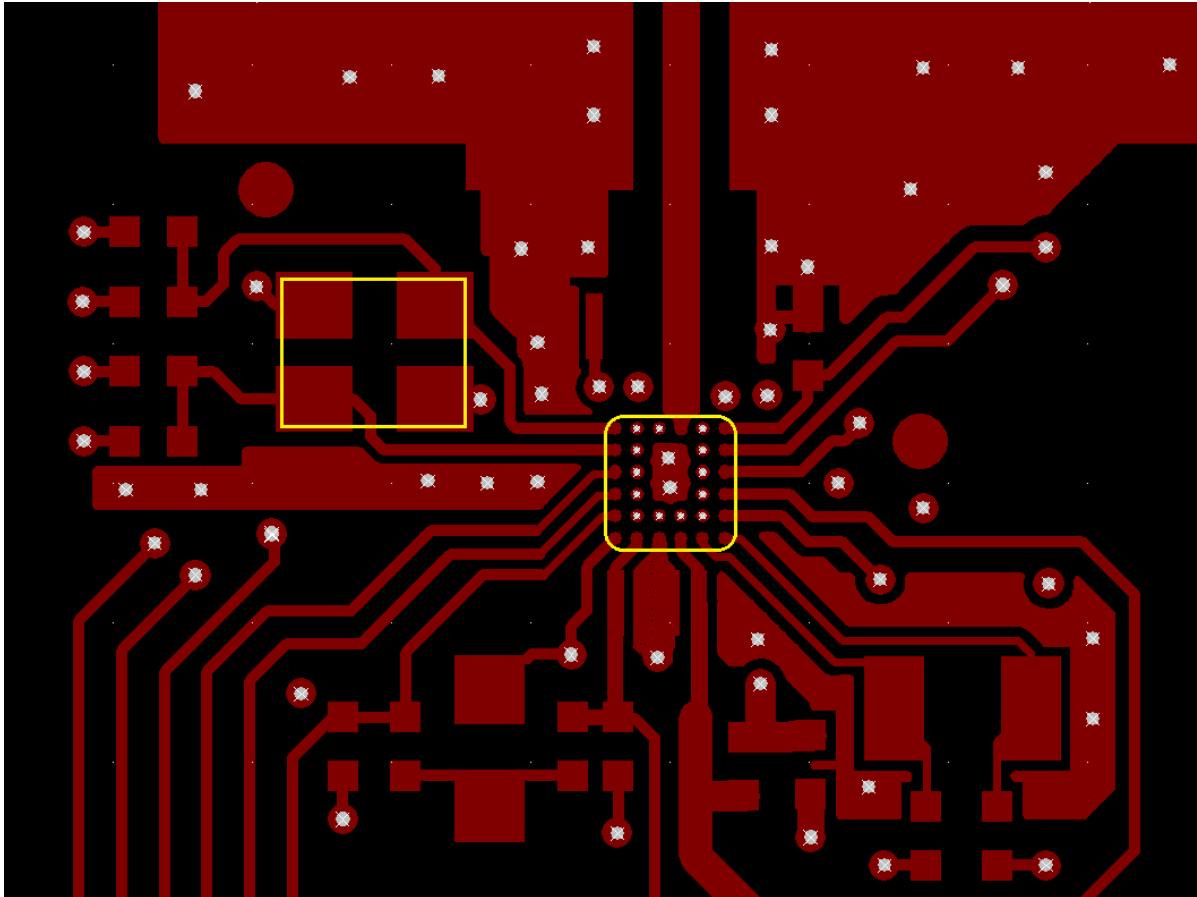

Figure 1. DA1458x_CB_PXI_WLCSP board layout snapshot

- Active components operating at high frequency should have as compact a layout as possible. This prevents cross-coupling between lines and parasitic that has a negative effect on the operating parameters.
- Always provide a solid grounding to the radio IC. Use as many vias as possible to create a solid GND under the IC itself and connect it to inner and bottom GND layers.

3.2 RF Transmission Lines, Filters, and Matching Networks

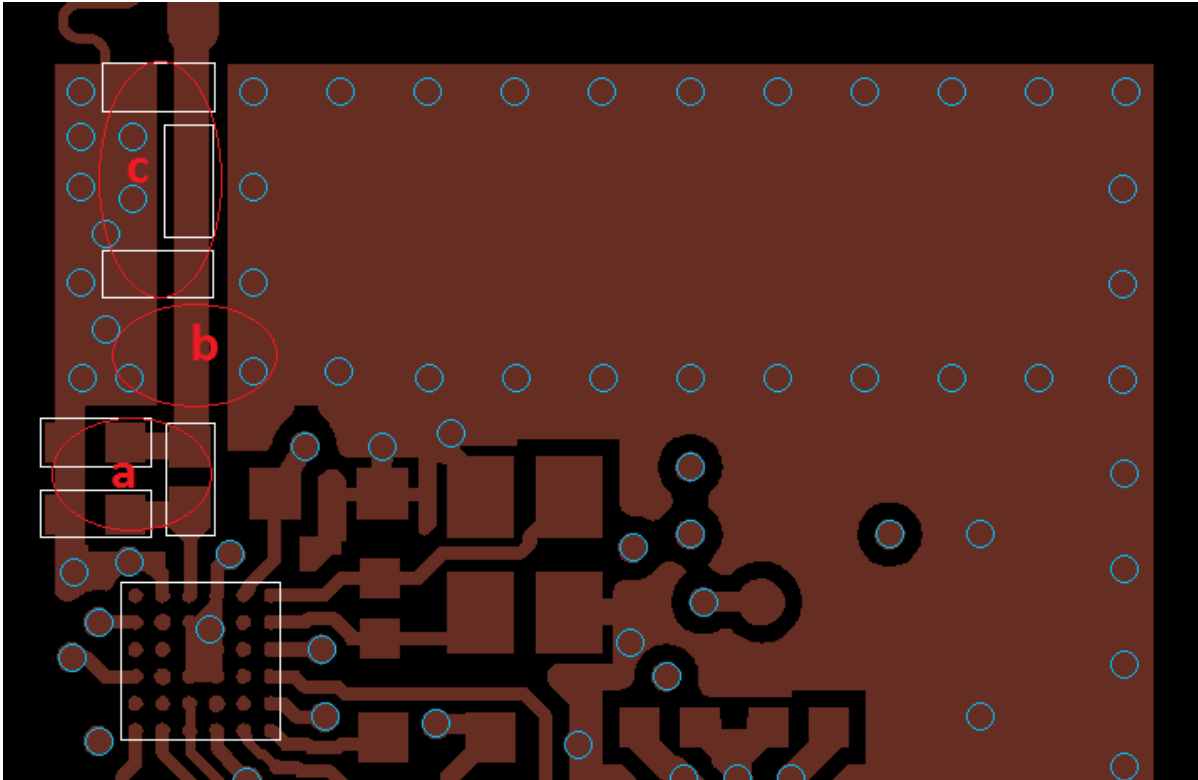

Figure 2. Placement of filters and matching networks

- Place radio matching components and any RF filters as close as possible to the radio IC.
 - Make sure the component's GNDs are connected to the same GND plane (left side of the transmission line above).
- Minimize the transmission line length between radio IC and antenna.
 - The characteristic impedance of the transmission line should match the required radio impedance (50 Ω).
 - Most current PCB layout tools have the possibility to calculate the characteristic impedance of the transmission line based on the stack-up and PCB material.
- Place antenna matching components as close as possible to the feeding point of the antenna.
 - Make sure the component's GNDs are connected to the same GND plane (left side of the transmission line above).

3.3 Antennas, General Considerations

Consider the following remarks before starting with an antenna design:

- Do not place metal layers below the antenna itself. The antenna footprint must be kept free of metal.
- Do not place metal screws, radiators, piezo buzzers, batteries, and so on in the proximity of the antenna.
 - As a rule of thumb, at least 5 mm should be allowed around the antenna footprint, both horizontally on the PCB and vertically around the PCB footprint.
- Do not use metal enclosures for products with antennas. This prevents the antenna from radiating and performing as intended.

4. Antennas on Multi-Layer Substrates

On a multi-layer PCB stack-up it is relatively easy to construct a good reference GND plane for the antenna. This is especially important because the most common antenna choice is the Inverted-F Antenna (IFA).

It is very important to understand that IFAs operate in conjunction with a GND plane. There is a minimum required size of the GND plane for efficient antenna operation. This parameter is specifically indicated for all designs below.

Depending on the available space on the PCB one can choose between a full-size IFA and a folded/shrunked version.

The full-size IFA has more broadband frequency characteristics and better radiation efficiency. The folded versions can reduce the space requirements by half and still achieve 100 MHz to 150 MHz bandwidth, which is enough to cover the Bluetooth low energy 2.4 GHz band (at -10 dB return loss).

The achievable radiation efficiency is between -1.5 dB and -3 dB. Efficiency is affected by the PCB material; therefore, it is recommended that FR4 (low loss) substrate material is used.

The antennas in the following sections were designed and measured using:

- FR4 PCB substrate material
- Two or more metal (copper) layers.

The dimensions given below are based on laboratory measurements and are optimized for the given stack-up and board size.

Variations in board thickness or substrate material have an effect on the antenna matching. Also, when the antenna is in proximity to a plastic enclosure the optimum dimensions and matching components may be different.

4.1 Full Size Printed IFA, 1 mm Substrate

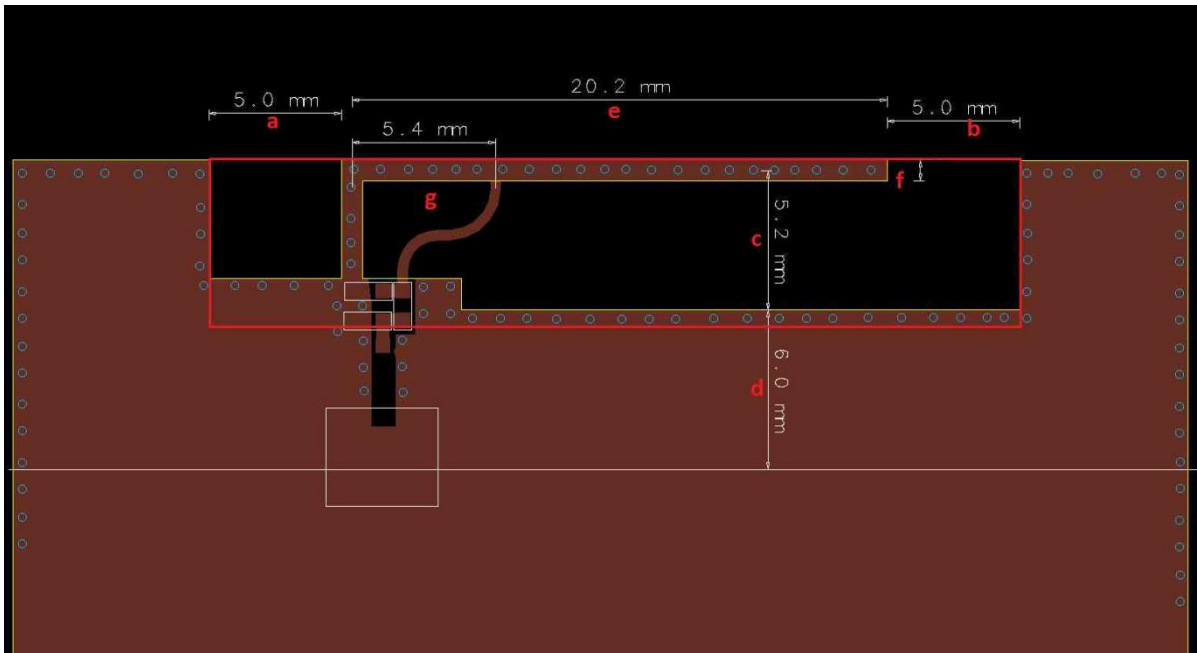

Figure 3. Full size IFA with dimensions

The red outline indicates the antenna footprint, that is the required allocation of PCB space. The antenna footprint is available on request in DXF format.

Legend (see [Figure 3](#)):

- a. Clearance between antenna arm and GND plane left.
- b. Clearance between antenna arm and GND plane right.
 - i. For narrow PCBs (a) and (b) coincide with board edges.
 - ii. The two GND pieces left and right of the antenna are NOT required for correct antenna operation.
- c. Clearance between antenna arm and GND plane below.
- d. Minimum GND plane size required for correct operation of the antenna.
- e. Antenna width.
 - i. The antenna is implemented on top and bottom layers and stitched together using vias.
 - ii. The feeding line (from indicated matching components) is implemented on top layer only.
- f. Antenna trace width (0.6 mm).
- g. Feed point position.

4.1.1 Matching Network

The matching is subject to change depending on substrate type or thickness and enclosure material (type and proximity to PCB).

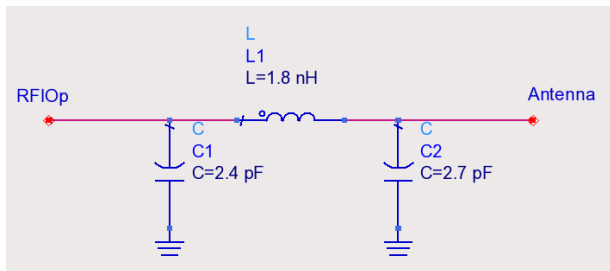

Figure 4. Matching components, full size IFA

- C1: 2.4 pF, 0402, GRM15 series, Murata.
- L1: 1.8 nH, 0402, LQP series, Murata.
- C2: 2.7 pF, 0402, GRM15 series, Murata.
- In addition to the matching network, a 3.3 nH or 3.9 nH coil (depending on the package, check the hardware designs application notes) is required close to the RFIO pin.

4.1.2 Measured Return Loss

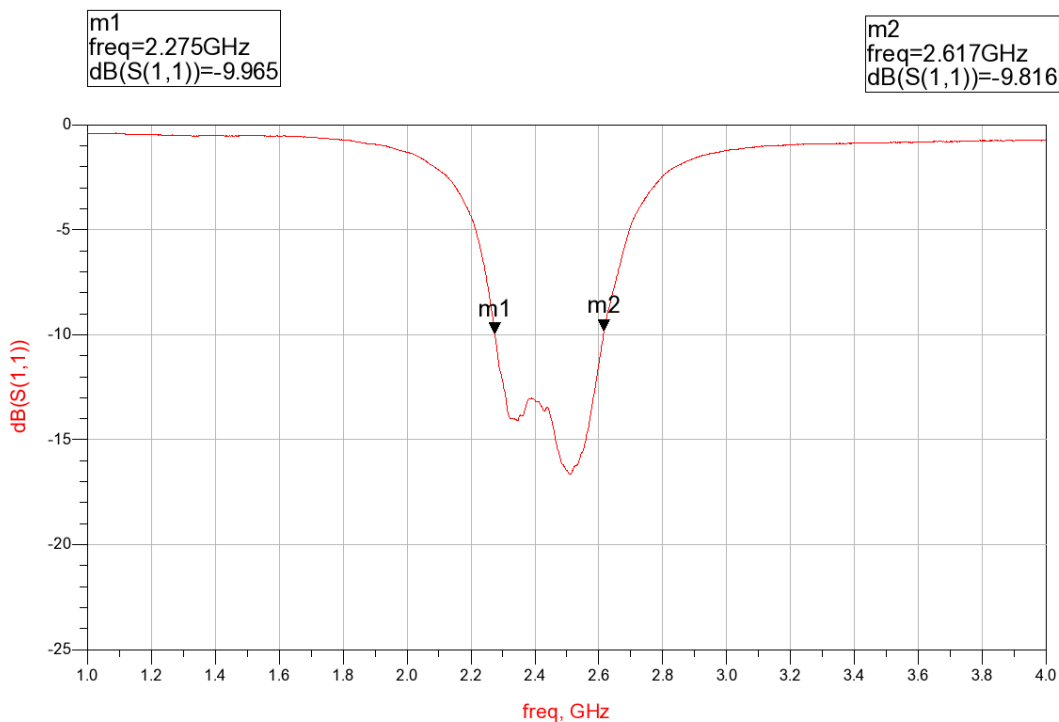

Figure 5. Measured S11, full size IFA

4.1.3 Measured Radiation Pattern

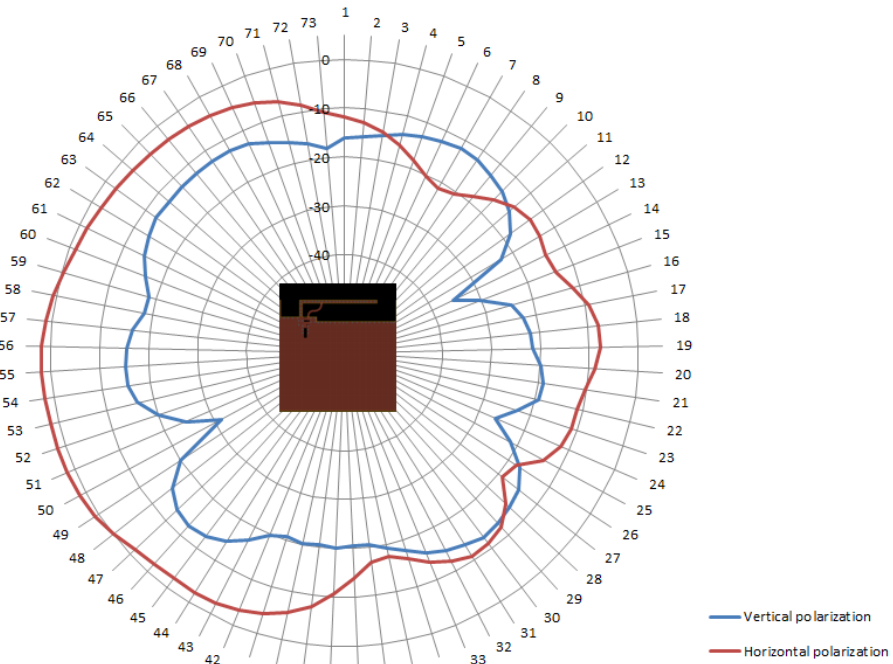

Figure 6. Radiation pattern, PCB horizontal, full-size IFA

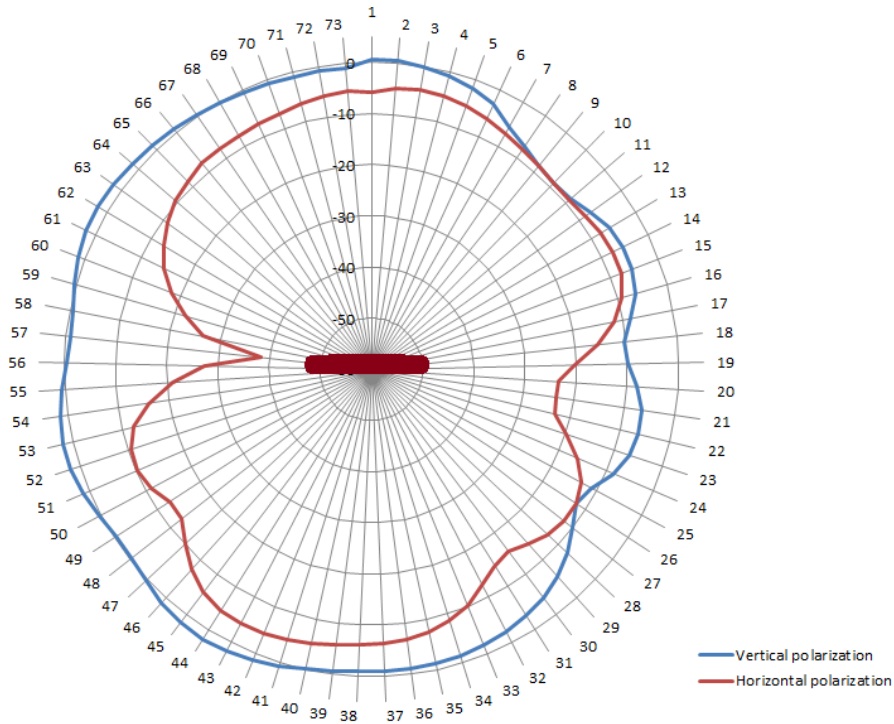

Figure 7. Radiation pattern, PCB vertical, full-size IFA

4.2 Reduced Size Printed IFA, 1 mm Substrate, Variant 1

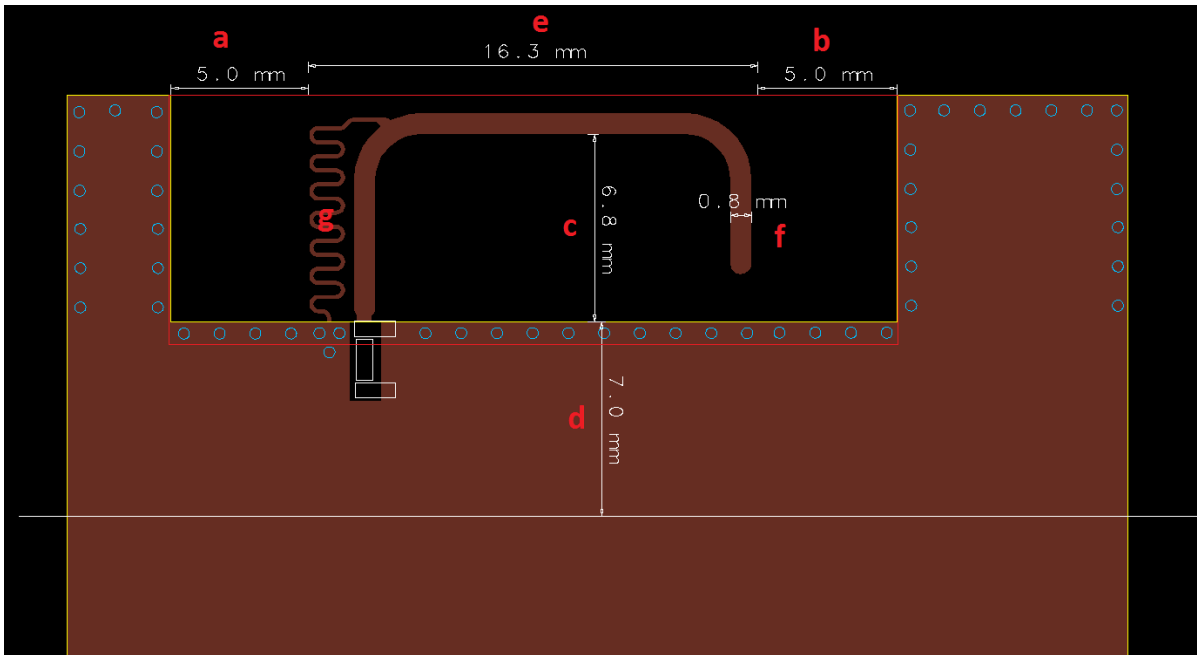

Figure 8. Reduced size IFA, variant 1

The red outline indicates the antenna footprint, that is the required allocation of PCB space. The antenna is implemented on the TOP layer only. The antenna footprint is available on request in DXF format.

Legend (see [Figure 4](#)):

- a. Clearance between antenna and GND plane left.
- b. Clearance between antenna and GND plane right.
 - i. For narrow PCBs (a) and (b) coincide with board edges.
 - ii. The two GND pieces left and right of the antenna are NOT required for correct antenna operation.
- c. Clearance between antenna arm and GND plane below.
- d. Minimum GND plane size required for correct operation of the antenna.
- e. Antenna width.
- f. Antenna main arm.
 - i. Width: 0.8 mm (30 mil).
 - ii. Length: 24.4 mm (961 mil).
- g. Antenna meander arm.
 - i. Implemented on the TOP layer only.
 - ii. Width: 0.153 mm (6 mil).
 - iii. Length: 21.22 mm (835.5 mil).

4.2.1 Matching Network

The matching is subject to change depending on substrate type or thickness and enclosure material (type and proximity to PCB).

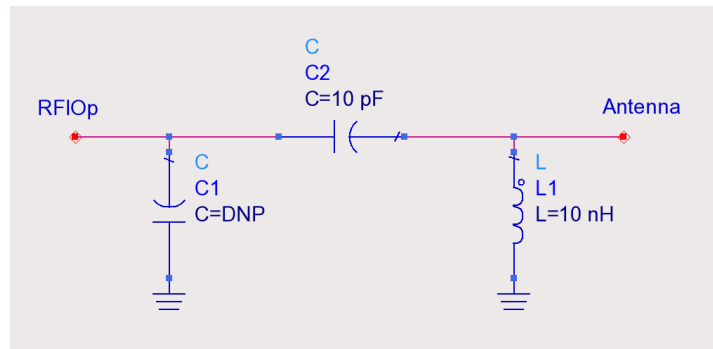

Figure 9. Matching components, reduced size IFA, variant 1

- C1: DNP.
- C2: 10 pF, 0402, GRM15 series, Murata.
- L1: 10 nH, 0402, LQP series, Murata.
- In addition to the matching network, a 3.3 nH or 3.9 nH coil (depending on the package, check the hardware designs application notes) is required close to the RFIO pin.

4.2.2 Measured Return Loss

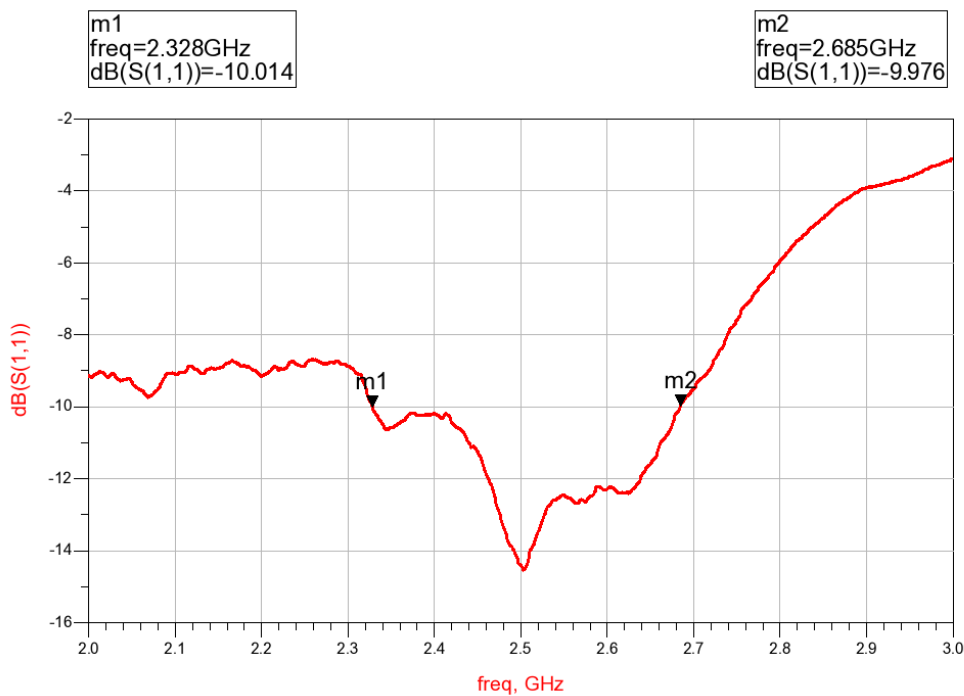

Figure 10. Measured S11, reduced size IFA, variant 1

4.2.3 Measured Radiation Pattern

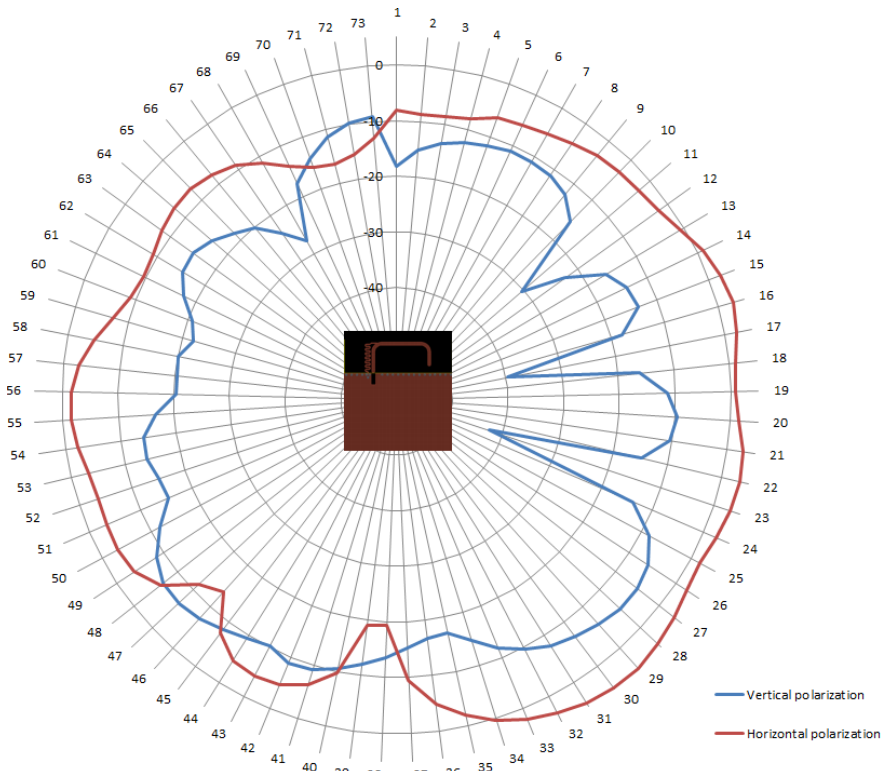

Figure 11. Radiation pattern, PCB horizontal, reduced size IFA, variant 1

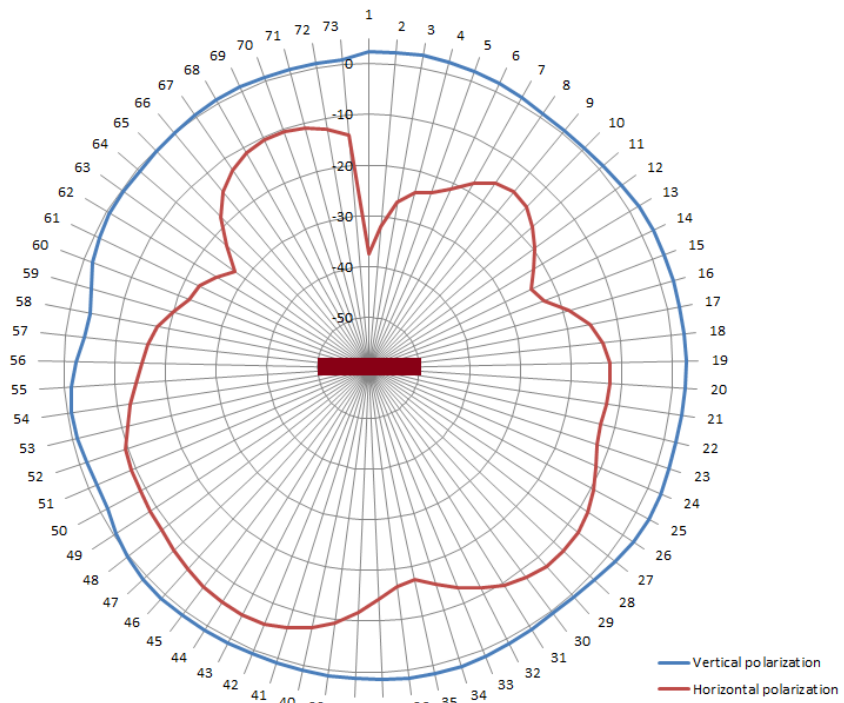

Figure 12. Radiation pattern, PCB vertical, reduced size IFA, variant 1

4.3 Reduced Size Printed IFA, 1 mm Substrate, Variant 2

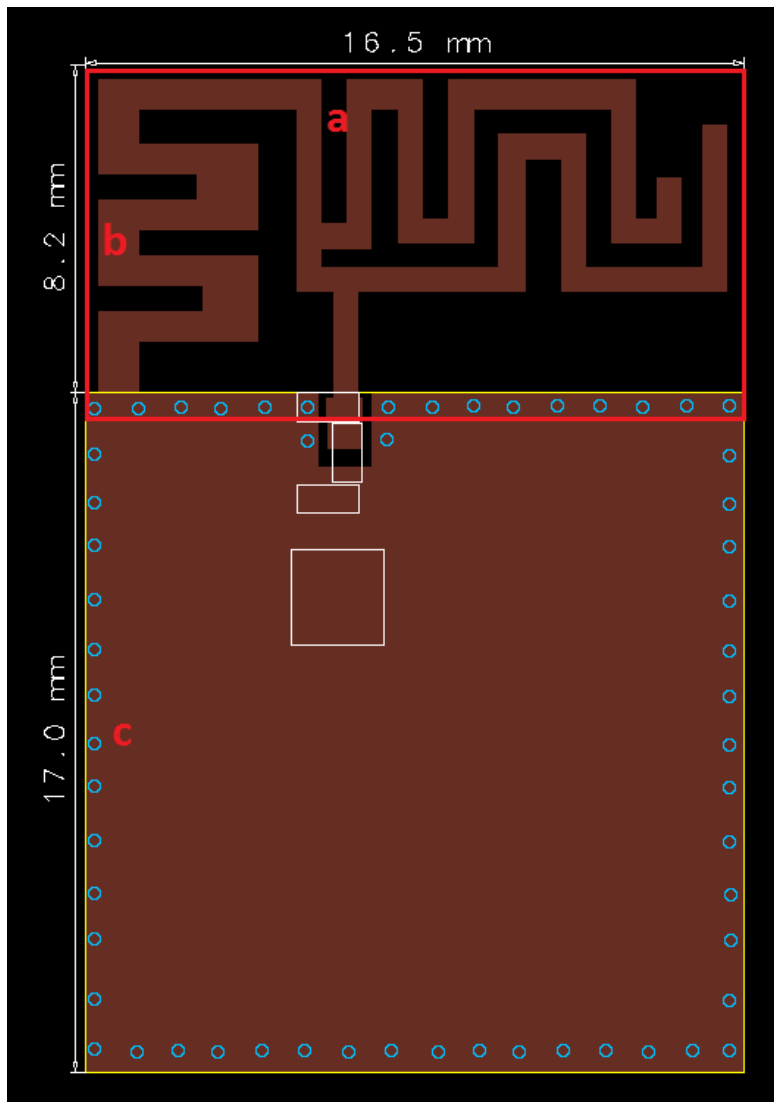

Figure 13. Reduced size IFA, variant 2

The red outline indicates the antenna footprint, that is required allocation of PCB space. The antenna is implemented on the TOP layer only. The antenna footprint is available on request in DXF format.

Legend (see [Figure 13](#)):

- a. Antenna footprint width.
- b. Antenna footprint height.
- c. Minimum GND plane size required for correct operation of the antenna.

4.3.1 Matching Network

The matching is subject to change depending on substrate type or thickness and enclosure material (type and proximity to PCB).

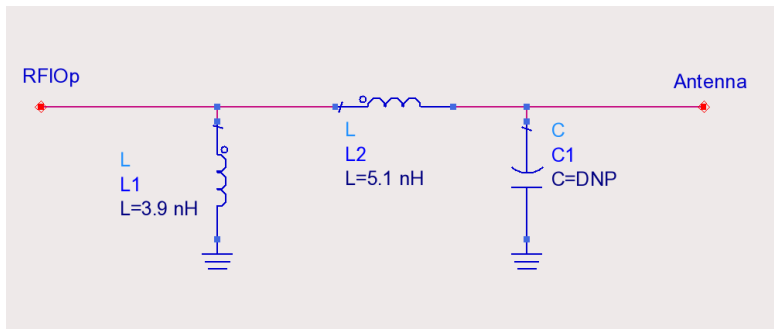

Figure 14. Matching components, reduced size IFA, variant 2

- L1: 3.9 nH, 0402, LQP series, Murata.
- L2: 5.1 nH, 0402, LQP series, Murata.
- C1, DNP.
- In addition to the matching network, a 3.3 nH or 3.9 nH coil (depending on the package, check the hardware designs application notes) is required close to the RFIOp pin.

4.3.2 Measured Return Loss

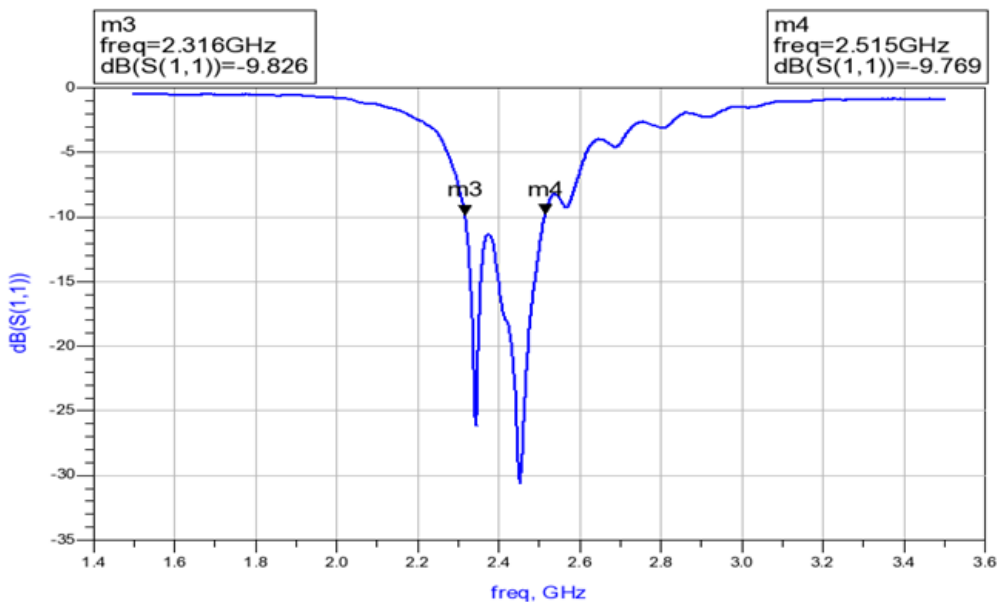

Figure 15. Measured S11, reduced size IFA, variant 2

4.3.3 Measured Radiation Pattern

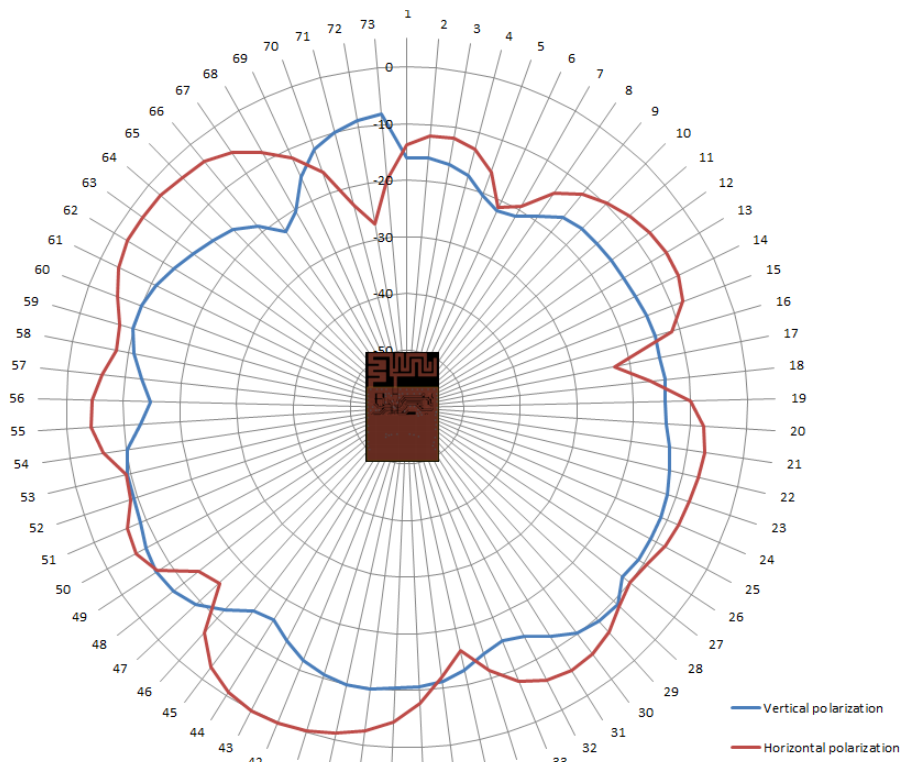

Figure 16. Radiation pattern, PCB horizontal, reduced size IFA, variant 2

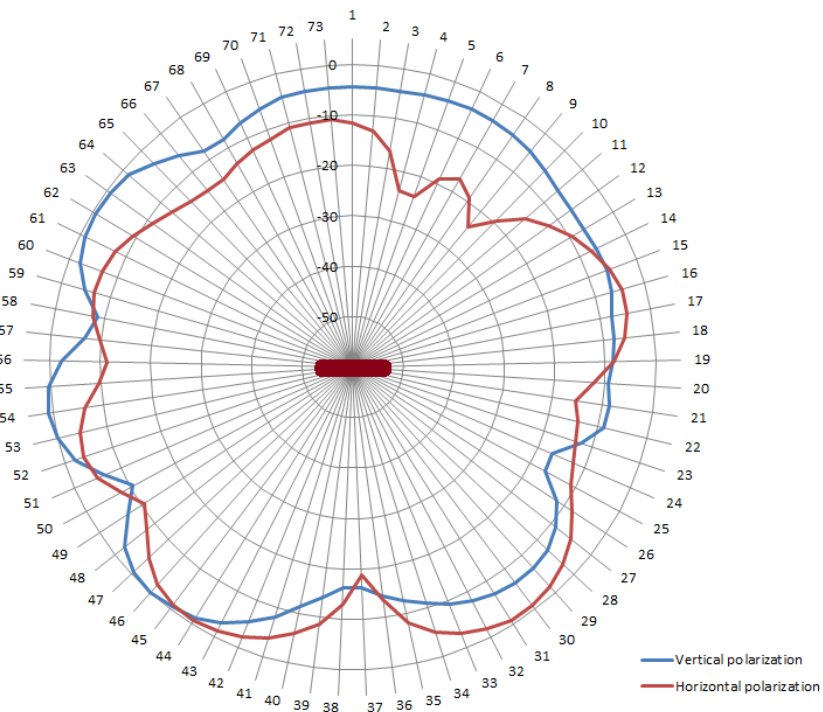

Figure 17. Radiation pattern, PCB vertical, reduced size IFA, variant 2

4.4 ZOR Antenna, 1.6 mm Substrate

This variant of the Zeroth Order Resonance (ZOR) antenna is designed for a substrate thickness of 1.6 mm and requires a minimum of two layers. The TOP and BOTTOM layers are used below.

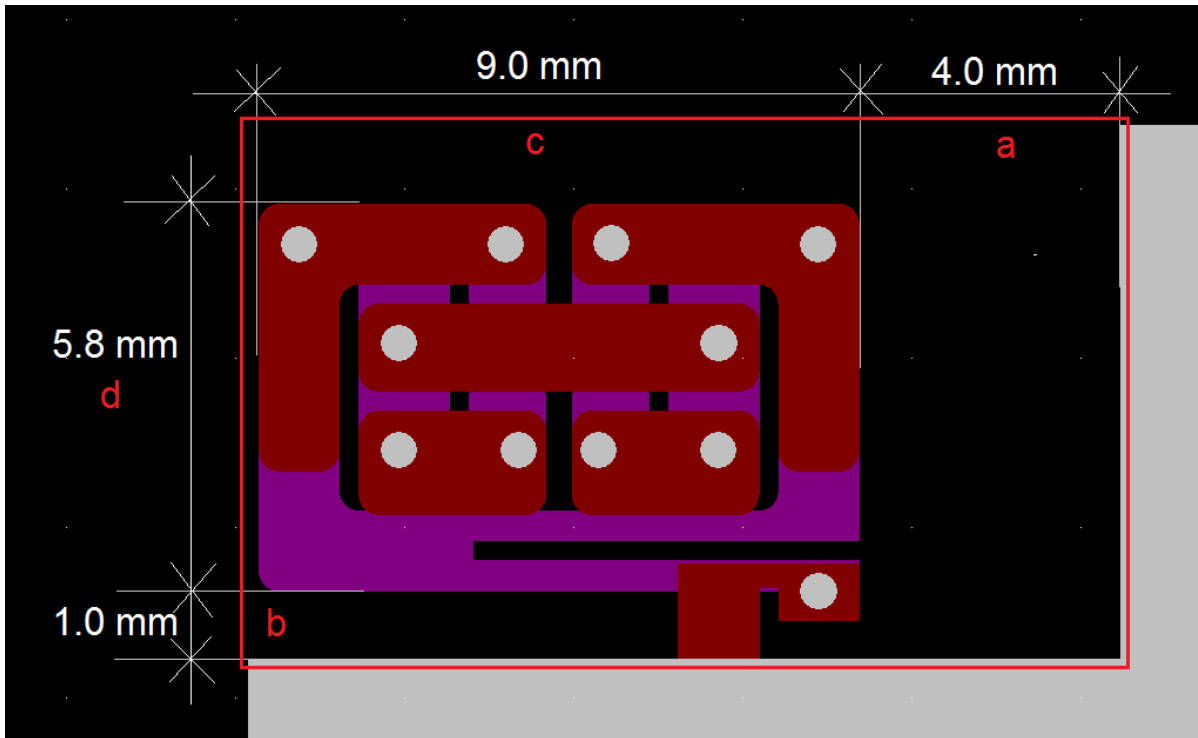

Figure 18. ZOR antenna preview

The red outline indicates the antenna footprint, that is required allocation of PCB space. The antenna footprint is available on request in DXF format.

Legend (see [Figure 18](#)):

- a. Clearance between antenna and GND plane right.
 - i. 4.0 mm (157.5 mil).
 - ii. The GND on the right of the antenna is NOT required for correct antenna operation.
- b. Clearance between antenna and GND plane below.
 - i. 1.0 mm (39 mil).
- c. Antenna length
 - i. 9.0 mm (354 mil).
- d. Antenna width
 - i. 5.8 mm (228 mil).

4.4.1 Matching Network

The matching is subject to change depending on substrate type or thickness and enclosure material (type and proximity to PCB).

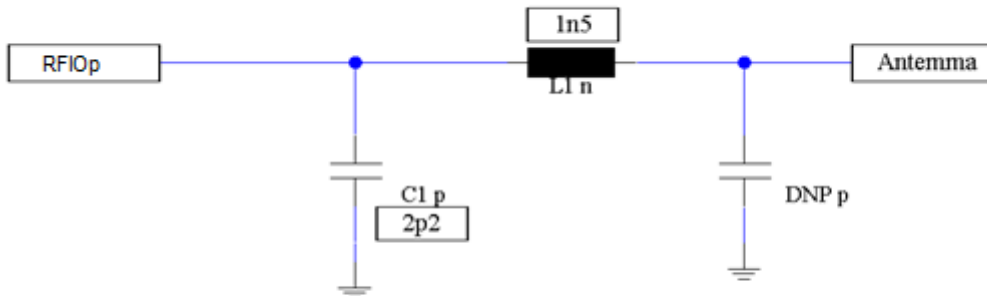

Figure 19. Matching components, ZOR antenna, 1.6 mm substrate

- L1: 1.5 nH, 0402, LQP series, Murata.
- C1, 2.2 pF, 0402, GRM series, Murata.
- In addition to the matching network, a 3.3 nH or 3.9 nH coil (depending on the package, check the hardware designs application notes) is required close to the RFIO pin.

4.4.2 Measured Return Loss

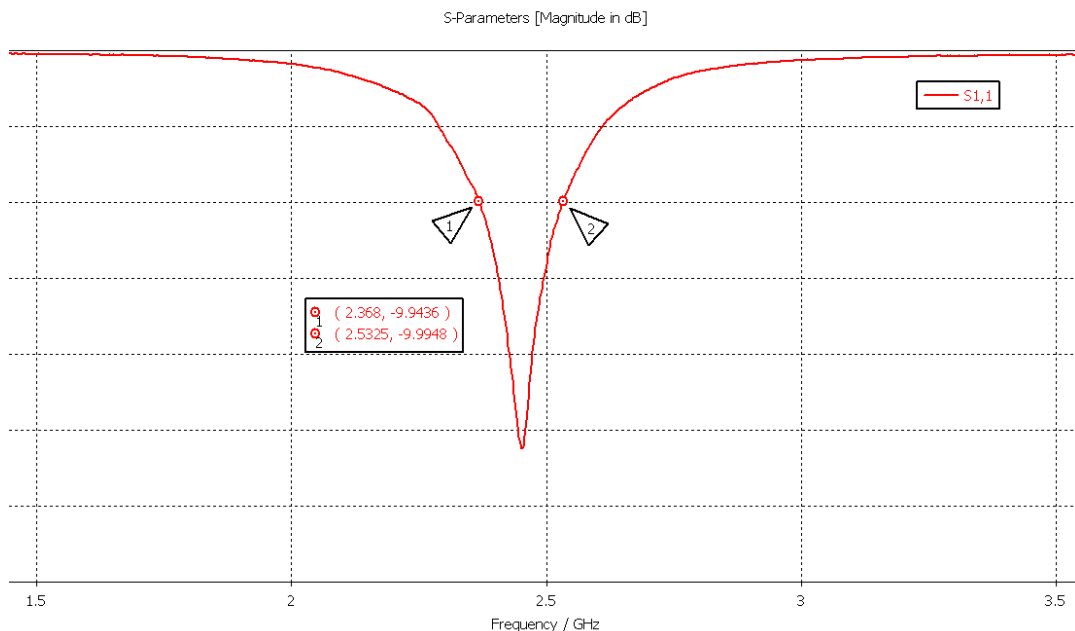

Figure 20. Measured S11, ZOR antenna, 1.6 mm substrate

4.4.3 Measured Radiation Pattern

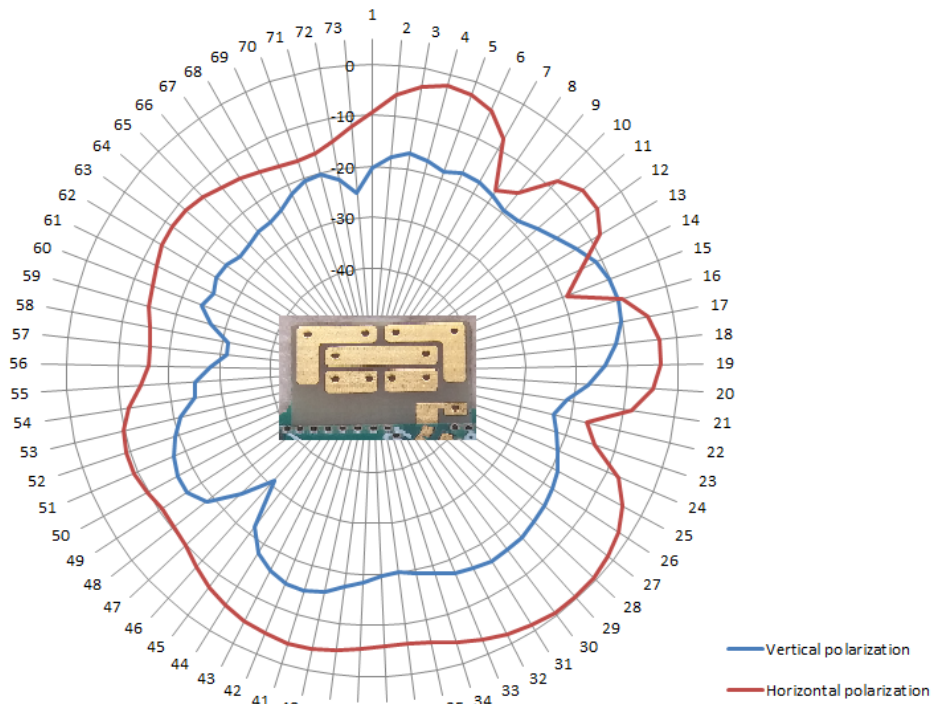

Figure 21. Radiation pattern, DUT horizontal, ZOR antenna, 1.6 mm substrate

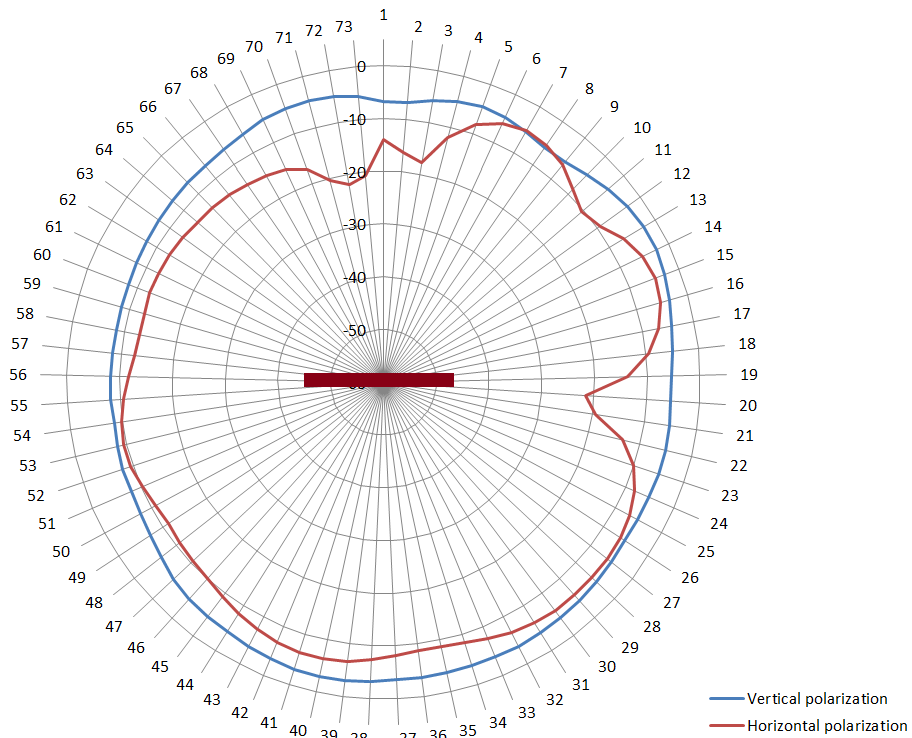

Figure 22. Radiation pattern, DUT vertical, ZOR antenna, 1.6 mm substrate

4.5 ZOR Antenna, 1.0 mm Substrate

This variant of the Zeroth Order Resonance (ZOR) antenna is designed for a substrate thickness of 1.0 mm and requires a minimum of two layers. The TOP and BOTTOM layers are used below.

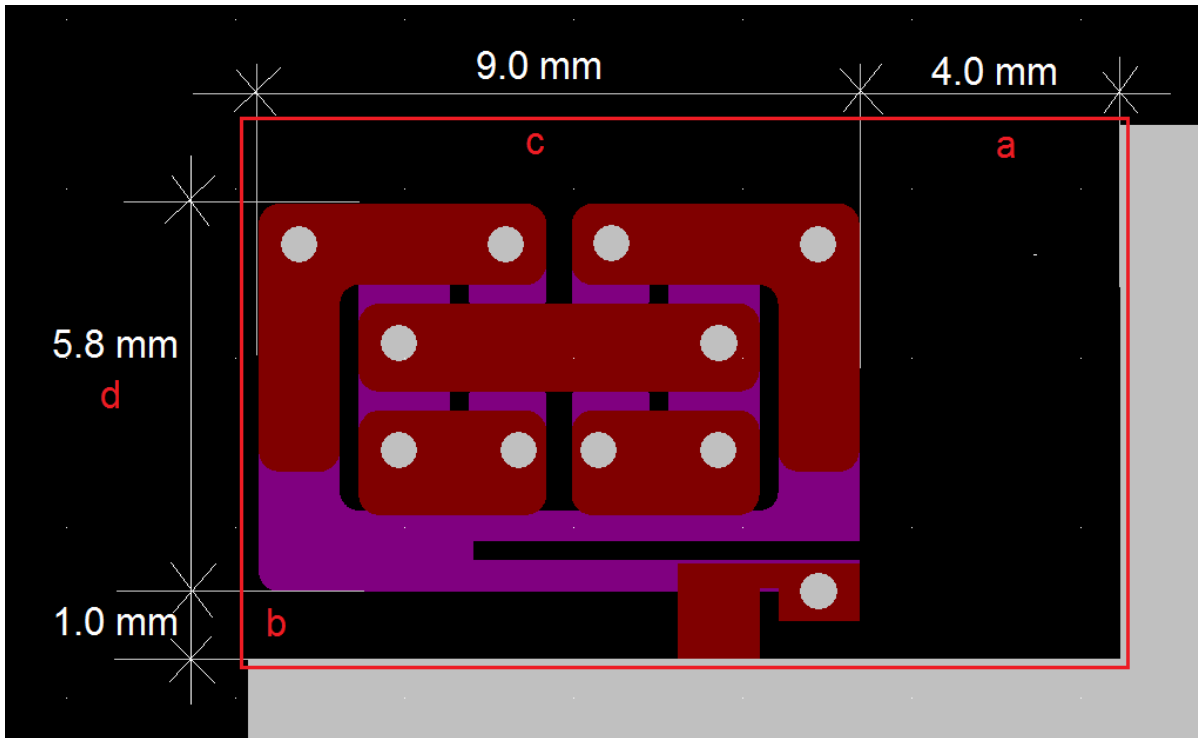

Figure 23. ZOR antenna preview

The red outline indicates the antenna footprint, that is the required allocation of PCB space. The antenna footprint is available on request in DXF format.

Legend (see Figure 23):

- a. Clearance between antenna and GND plane right.
 - i. 4.0 mm (157.5 mil).
 - ii. The GND on the right of the antenna is NOT required for correct antenna operation.
- b. Clearance between antenna and GND plane below.
 - i. 1.0 mm (39 mil).
- c. Antenna length
 - i. 9.0 mm (354 mil).
- d. Antenna width
 - i. 5.8 mm (228 mil).

4.5.1 Matching Network

The matching is subject to change depending on substrate type or thickness and enclosure material (type and proximity to PCB).

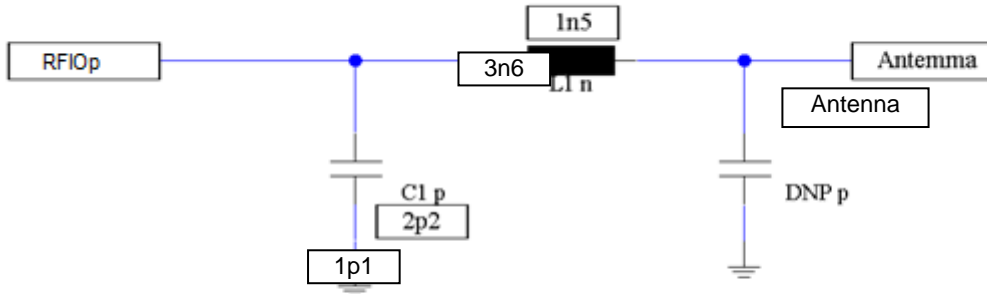

Figure 24. Matching components, ZOR antenna, 1.0 mm substrate

- L1: 3.6 nH, 0402, LQP series, Murata.
- C1, 1.1 pF, 0402, GRM series, Murata.
- In addition to the matching network, a 3.3 nH or 3.9 nH coil (depending on the package, check the hardware designs application notes) is required close to the RFIO pin.

4.5.2 Measured Return Loss

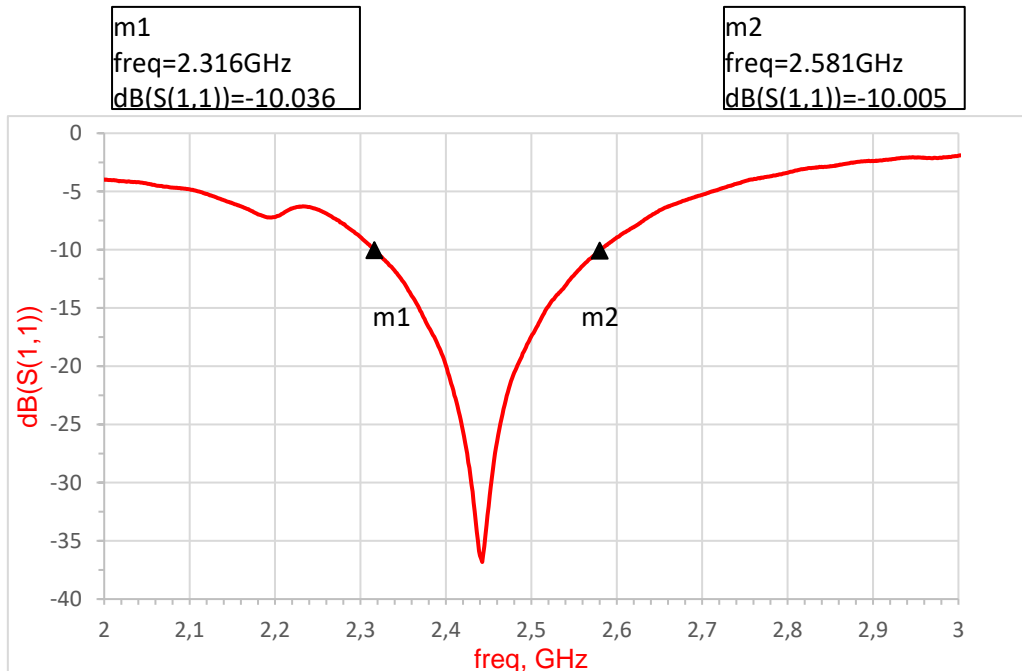

Figure 25. Measured S11, ZOR antenna, 1.0 mm substrate

4.5.3 Measured Radiation Pattern

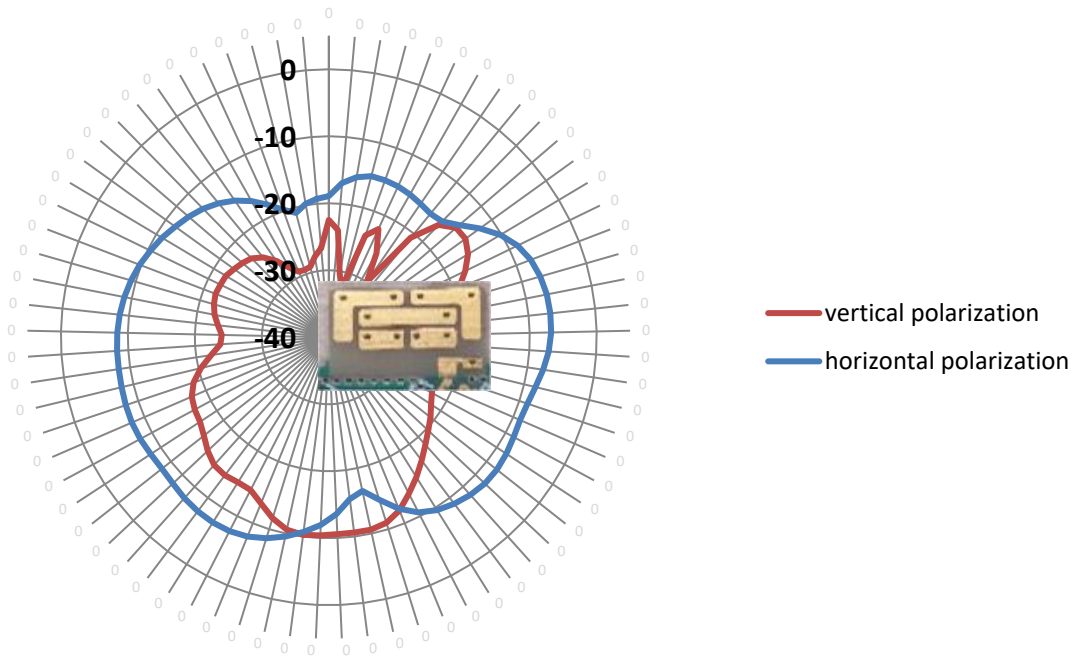

Figure 26. Radiation pattern, DUT horizontal, ZOR antenna, 1.0 mm substrate

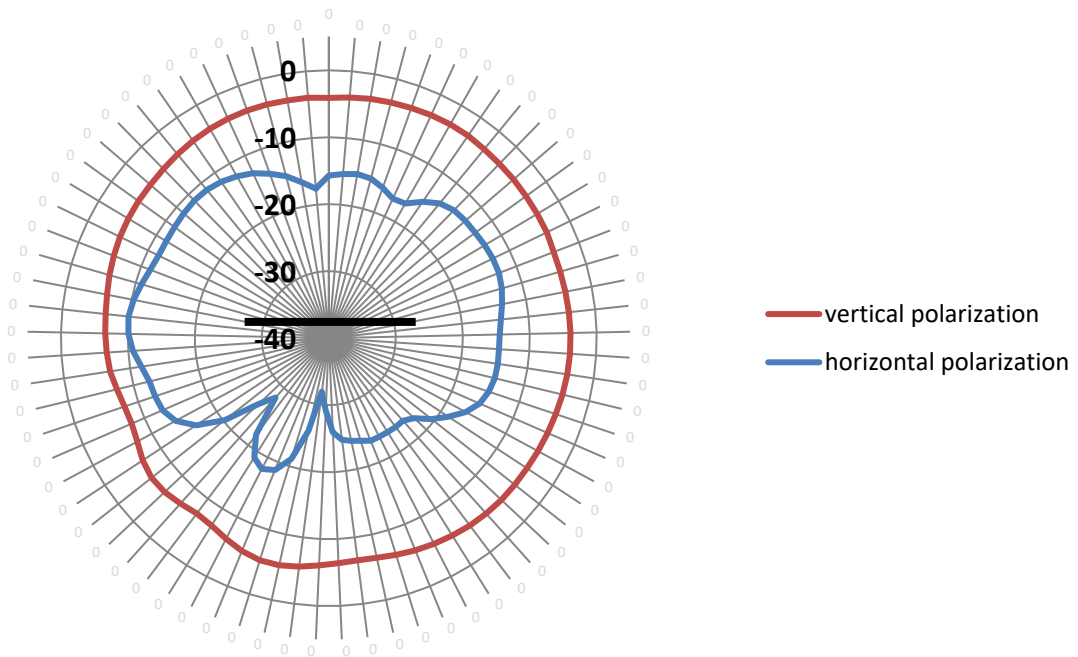

Figure 27. Radiation pattern, DUT vertical, ZOR antenna, 1.0 mm substrate

5. Antennas on Single Layer Substrates

Single layer substrates require a different approach regarding antennas.

Due to limited space and possibility to construct a continuous GND plane, printed dipoles are often used instead of IFAs. The dipole requires a balun when the radio input is single ended and therefore has additional costs in components.

Due to the single ended input of the Bluetooth LE device, the IFA is still the best choice, but care must be taken that a proper GND plane is available. There are two main aspects to take care of:

- Continuous GND plane at the antenna (see Section 5.2).
- Minimum GND plane size for correct antenna operation.

Because the antenna is implemented on one metal layer, the size of the antenna is slightly larger than the equivalent multi-layer design.

Single layer substrates are usually used to reduce cost but have a lower RF performance due to higher transmission losses. This has a direct impact on the radiation efficiency. A typical IFA on a single layer substrate has a radiation efficiency between -2.5 dB and -5 dB.

5.1 Carbon Layers

Single layer PCBs are often used for low cost remote controls. It is common to use a carbon layer for the keyboard matrix or to have carbon bridges to route signals. The following rules must be applied to ensure maximum RF performance:

- Do not route RF signals in carbon.
- Do not cross RF transmission lines with carbon bridges.
 - An exception can be made when the carbon layer is on the other side of the PCB (that is copper on TOP and carbon on BOTTOM).
- Do not place carbon under the antenna.
 - The carbon is a conductive high loss material and acts as an absorber, thereby drastically reducing the radiation efficiency and the range of the antenna.

5.2 Single Layer Printed IFA, 1 mm Substrate

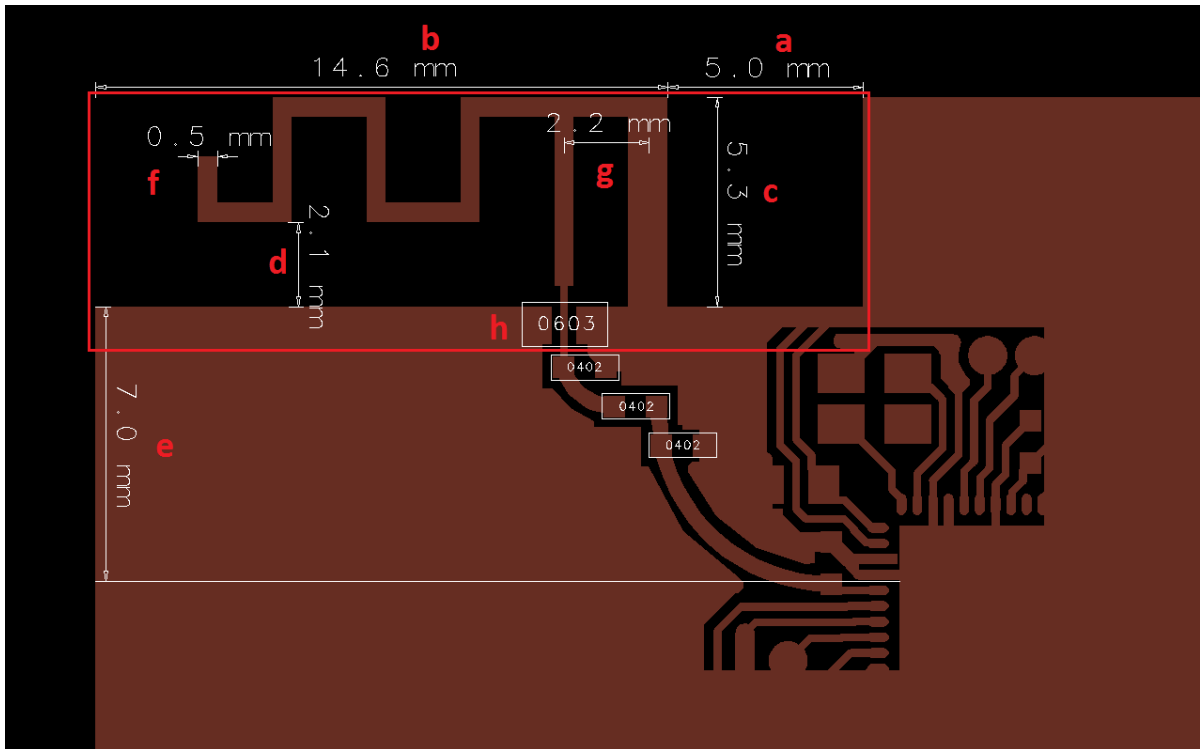

Figure 28. Single layer IFA

The dimensions above are given for a typical single layer PCB substrate, 1 mm thick. The antenna length is adjusted for resonance, including a 1 mm plastic enclosure placed in contact with the PCB antenna.

The red outline indicates the antenna footprint, that is the required allocation of PCB space. The antenna footprint is available on request in DXF format.

Legend (see [Figure 28](#)):

- a. Clearance between antenna arm and GND plane right.
- b. Antenna width.
- c. Antenna height.
- d. Clearance between the antenna arm and GND plane below.
- e. Minimum GND plane size required for correct operation of the antenna.
- f. Antenna trace width.
- g. Feed point position.
- h. 0 Ω 0603 resistor used to connect the two sides of the GND planes.
 - i. When no DC connection is required, a 10 pF capacitor can also be used.
 - ii. This component is essential for the correct operation of the antenna.

5.2.1 Matching Network

The matching is subject to change depending on substrate type or thickness and enclosure material (type and proximity to PCB).

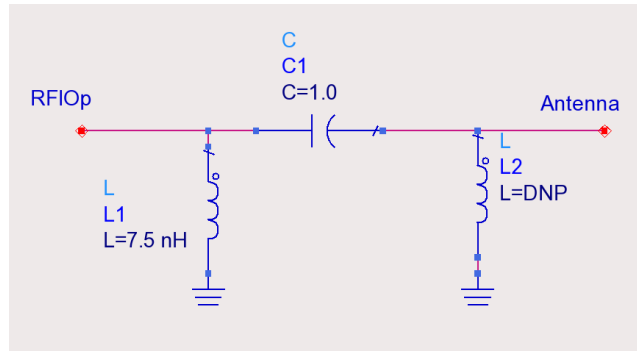

Figure 29. Matching components, single layer IFA

- L1: 7.5 nH, 0402, LQP series, Murata.
- C1: 1.0 pF, 0402, GRM15 series, Murata.
- L2: DNP.
- In addition to the matching network, a 3.3 nH or 3.9 nH coil (depending on the Bluetooth LE devicepackage) is required close to the RFIO pin.

5.2.2 Measured Return Loss

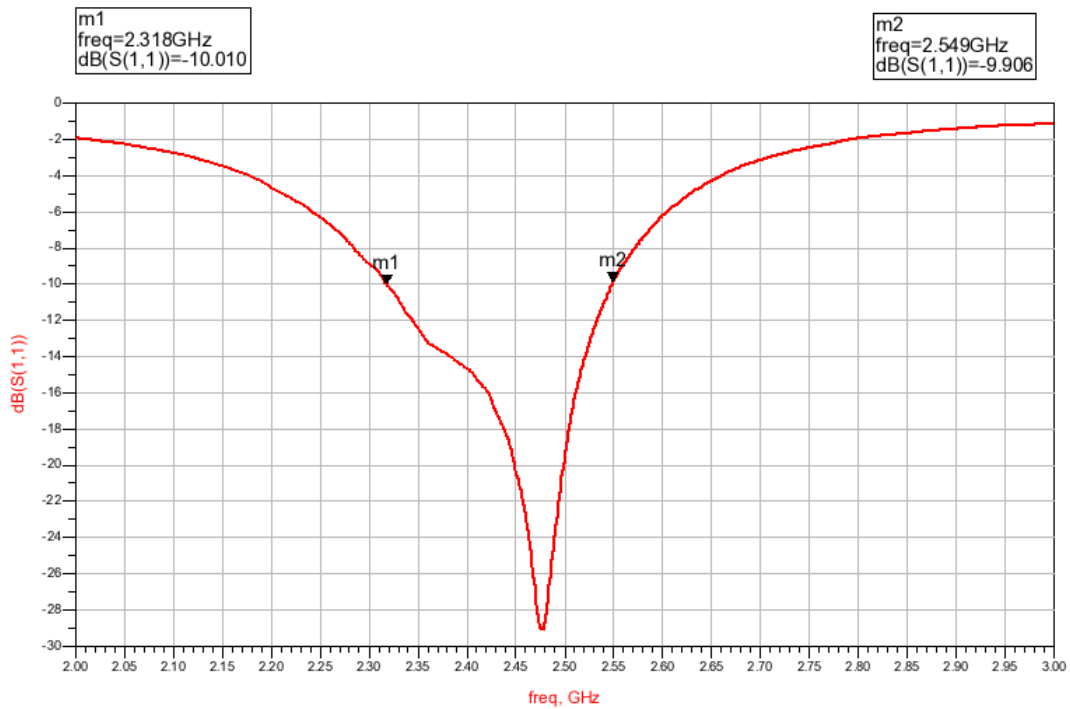

Figure 30. Measured S11, single layer IFA

5.2.3 Measured Radiation Pattern

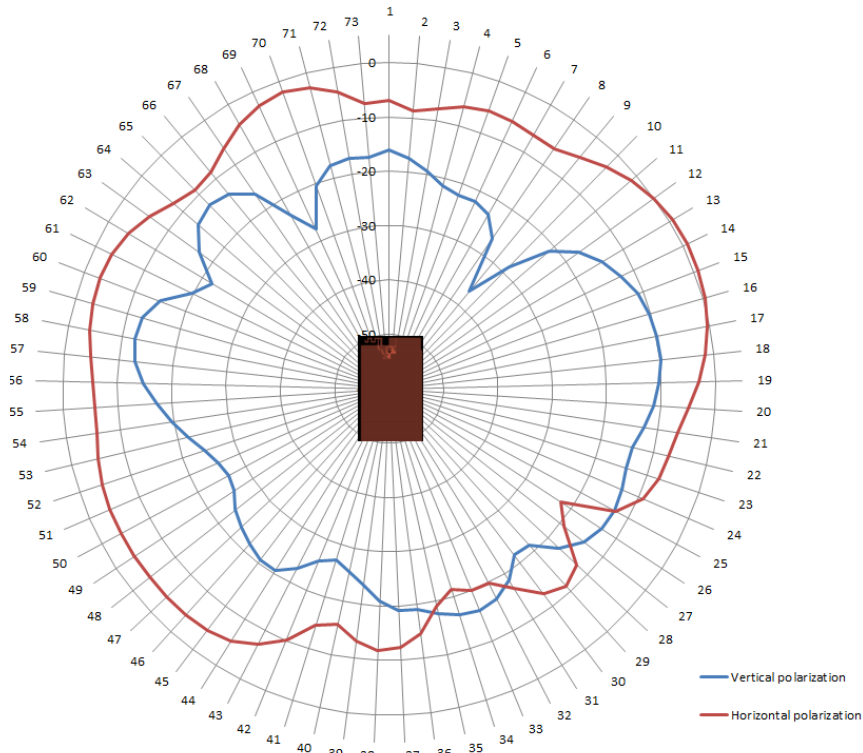

Figure 31. Radiation pattern, PCB horizontal, single layer IFA

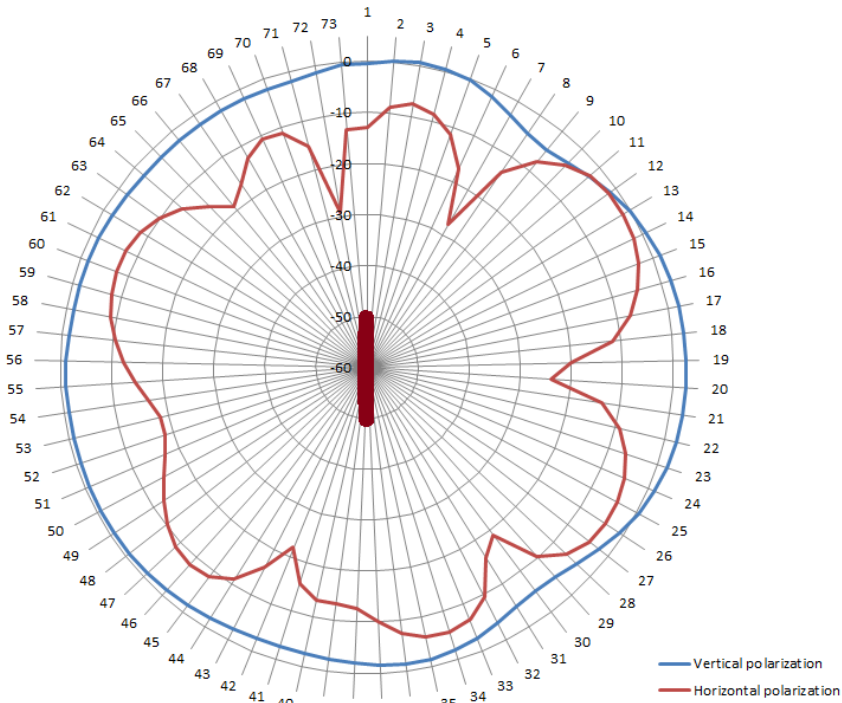

Figure 32. Radiation pattern, PCB vertical, single layer IFA

6. Conclusions

Antennas play an important role in the overall performance of any radio-based equipment. The guidelines in this document enables customers to integrate printed low-cost antennas in their Bluetooth low energy products with minimum effort and RF knowledge.

The antennas were designed, tested, and measured at Renesas Electronics and are currently used in many of our customers' products.

7. Revision History

Revision	Date	Description
2.5	June 27, 2024	Editorial changes. Updated to Renesas template.
2.4	Feb 22, 2022	Updated logo, disclaimer, copyright.
2.3	June 25, 2020	Editorial changes.
2.2	Feb 22, 2017	Generalizing the document for DA1458x family.
2.1	Jan 4, 2017	Added ZOR antenna, 1.0 mm substrate (section 4.5).
2.0	July 26, 2016	Added ZOR antenna, 1.6 mm substrate (section 4.4).
1.0	Aug 29, 2014	Initial version.

STATUS DEFINITIONS

Status	Definition
DRAFT	The content of this document is under review and subject to formal approval, which may result in modifications or additions.
APPROVED or unmarked	The content of this document has been approved for publication.

IMPORTANT NOTICE AND DISCLAIMER

RENESAS ELECTRONICS CORPORATION AND ITS SUBSIDIARIES (“RENESAS”) PROVIDES TECHNICAL SPECIFICATIONS AND RELIABILITY DATA (INCLUDING DATASHEETS), DESIGN RESOURCES (INCLUDING REFERENCE DESIGNS), APPLICATION OR OTHER DESIGN ADVICE, WEB TOOLS, SAFETY INFORMATION, AND OTHER RESOURCES “AS IS” AND WITH ALL FAULTS, AND DISCLAIMS ALL WARRANTIES, EXPRESS OR IMPLIED, INCLUDING, WITHOUT LIMITATION, ANY IMPLIED WARRANTIES OF MERCHANTABILITY, FITNESS FOR A PARTICULAR PURPOSE, OR NON-INFRINGEMENT OF THIRD-PARTY INTELLECTUAL PROPERTY RIGHTS.

These resources are intended for developers who are designing with Renesas products. You are solely responsible for (1) selecting the appropriate products for your application, (2) designing, validating, and testing your application, and (3) ensuring your application meets applicable standards, and any other safety, security, or other requirements. These resources are subject to change without notice. Renesas grants you permission to use these resources only to develop an application that uses Renesas products. Other reproduction or use of these resources is strictly prohibited. No license is granted to any other Renesas intellectual property or to any third-party intellectual property. Renesas disclaims responsibility for, and you will fully indemnify Renesas and its representatives against, any claims, damages, costs, losses, or liabilities arising from your use of these resources. Renesas' products are provided only subject to Renesas' Terms and Conditions of Sale or other applicable terms agreed to in writing. No use of any Renesas resources expands or otherwise alters any applicable warranties or warranty disclaimers for these products.

(Disclaimer Rev.1.01 Jan 2024)

Corporate Headquarters

TOYOSU FORESIA, 3-2-24 Toyosu,
Koto-ku, Tokyo 135-0061, Japan
www.renesas.com

Trademarks

Renesas and the Renesas logo are trademarks of Renesas Electronics Corporation. All trademarks and registered trademarks are the property of their respective owners.

Contact Information

For further information on a product, technology, the most up-to-date version of a document, or your nearest sales office, please visit www.renesas.com/contact-us/.